

INTERNATIONAL
STANDARD

ISO
24490

Second edition
2016-03-15

**Cryogenic vessels — Pumps for
cryogenic service**

Réipients cryogéniques — Pompes pour service cryogénique



Reference number
ISO 24490:2016(E)

© ISO 2016



COPYRIGHT PROTECTED DOCUMENT

© ISO 2016, Published in Switzerland

All rights reserved. Unless otherwise specified, no part of this publication may be reproduced or utilized otherwise in any form or by any means, electronic or mechanical, including photocopying, or posting on the internet or an intranet, without prior written permission. Permission can be requested from either ISO at the address below or ISO's member body in the country of the requester.

ISO copyright office
Ch. de Blandonnet 8 • CP 401
CH-1214 Vernier, Geneva, Switzerland
Tel. +41 22 749 01 11
Fax +41 22 749 09 47
copyright@iso.org
www.iso.org

Contents

Page

Foreword	iv
1 Scope	1
2 Normative references	1
3 Terms and definitions	1
4 Requirements for pumps	2
4.1 General.....	2
4.2 Materials.....	2
4.2.1 General.....	2
4.2.2 Mechanical properties at low temperature.....	2
4.2.3 Corrosion resistance.....	3
4.2.4 Oxygen and oxidizing fluids compatibility.....	3
4.2.5 Hydrogen compatibility.....	4
4.3 Design.....	4
4.3.1 Pressure-containing parts.....	4
4.3.2 Performance.....	4
4.3.3 Clearances.....	4
4.3.4 Prevention of rubbing.....	4
4.3.5 Fastenings.....	4
4.3.6 Warm bearings.....	4
4.3.7 Cold bearings.....	4
4.3.8 Bearing lubrication.....	5
4.3.9 Shaft seals.....	5
4.3.10 Purging.....	5
4.3.11 Prevention of particle contamination.....	5
4.3.12 Specific requirement for flammable liquids.....	5
4.3.13 Protection against over-pressurization.....	6
4.3.14 Pump motors.....	6
5 Test procedures	6
5.1 Prototype testing.....	6
5.1.1 General.....	6
5.1.2 Design evaluation.....	6
5.1.3 Performance evaluation.....	6
5.1.4 Initial tests.....	6
5.1.5 Cryogenic tests.....	7
5.2 Production testing.....	7
5.2.1 General.....	7
5.2.2 Hydrostatic pressure test.....	7
5.2.3 Mechanical running and performance test.....	8
6 Cleanliness	8
7 Marking	8
Annex A (informative) Guidance on installation design	9
Annex B (informative) Acceptable materials for construction of centrifugal pumps for liquid oxygen	11
Bibliography	15

Foreword

ISO (the International Organization for Standardization) is a worldwide federation of national standards bodies (ISO member bodies). The work of preparing International Standards is normally carried out through ISO technical committees. Each member body interested in a subject for which a technical committee has been established has the right to be represented on that committee. International organizations, governmental and non-governmental, in liaison with ISO, also take part in the work. ISO collaborates closely with the International Electrotechnical Commission (IEC) on all matters of electrotechnical standardization.

The procedures used to develop this document and those intended for its further maintenance are described in the ISO/IEC Directives, Part 1. In particular the different approval criteria needed for the different types of ISO documents should be noted. This document was drafted in accordance with the editorial rules of the ISO/IEC Directives, Part 2 (see www.iso.org/directives).

Attention is drawn to the possibility that some of the elements of this document may be the subject of patent rights. ISO shall not be held responsible for identifying any or all such patent rights. Details of any patent rights identified during the development of the document will be in the Introduction and/or on the ISO list of patent declarations received (see www.iso.org/patents).

Any trade name used in this document is information given for the convenience of users and does not constitute an endorsement.

For an explanation on the meaning of ISO specific terms and expressions related to conformity assessment, as well as information about ISO's adherence to the WTO principles in the Technical Barriers to Trade (TBT) see the following URL: [Foreword - Supplementary information](#)

The committee responsible for this document is ISO/TC 220, *Cryogenic vessels*.

This second edition cancels and replaces the first edition (ISO 24490:2005), which has been technically revised.

Cryogenic vessels — Pumps for cryogenic service

1 Scope

This International Standard specifies the minimum requirements for the design, manufacture and testing of pumps for cryogenic service.

This International Standard is applicable to centrifugal pumps. However, it can be applied to other types of cryogenic pumps (e.g. reciprocating pumps), where applicable.

This International Standard also gives guidance on the design of installations (see Annex A).

It does not specify requirements for operation or maintenance.

NOTE For cryogenic fluids, see ISO 21029-1, ISO 20421-1 and/or ISO 21009-1.

2 Normative references

The following documents, in whole or in part, are normatively referenced in this document and are indispensable for its application. For dated references, only the edition cited applies. For undated references, the latest edition of the referenced document (including any amendments) applies.

ISO 5198, *Centrifugal, mixed flow and axial pumps — Code for hydraulic performance tests — Precision grade*

ISO 21010, *Cryogenic vessels — Gas/materials compatibility*

ISO 21028-1, *Cryogenic vessels — Toughness requirements for materials at cryogenic temperature — Part 1: Temperatures below -80 °C*

ISO 21028-2, *Cryogenic vessels — Toughness requirements for materials at cryogenic temperature — Part 2: Temperatures between -80 °C and -20 °C*

ISO 23208, *Cryogenic vessels — Cleanliness for cryogenic service*

3 Terms and definitions

For the purposes of this document, the following terms and definitions apply.

3.1

nominal size

DN

alphanumeric designation of size for components of a pipework system, which is used for reference purposes

Note 1 to entry: It comprises the letters DN followed by a dimensionless whole number which is indirectly related to the physical size, in millimetres, of the bore or outside diameter of the end connections.

Note 2 to entry: The number following the letters DN does not represent a measurable value and is not to be used for calculation purposes except where specified in the relevant standard.

Note 3 to entry: In those standards which use the DN designation system, any relationship between DN and component dimensions is given, e.g. DN/OD or DN/ID.

[SOURCE: ISO 6708:1995, 2.1, modified]

3.2
nominal pressure
PN

alphanumeric designation used for reference purposes related to a combination of mechanical and dimensional characteristics of a component of a pipework system

Note 1 to entry: It comprises the letters PN followed by a dimensionless number equal to at least the maximum allowable pressure in bar.

Note 2 to entry: For a pump, PN can be different for inlet and outlet.

Note 3 to entry: For Europe, PN equals the design pressure (PS) as defined in the Pressure Equipment Directive (2014/68/EU).

3.3
specified minimum temperature
lowest temperature for which the pump is specified

3.4
duty point
performance point defined by pressure or head and volume or mass flow rate

3.5
net positive suction head
NPSH

inlet total head increased by the head (in flowing liquid) corresponding to the atmospheric pressure at the test location and decreased by the sum of the head corresponding to the vapour pressure of the pump liquid at the inlet temperature and the inlet impeller height

Note 1 to entry: See also ISO 5198:1987, Table 1.

4 Requirements for pumps

4.1 General

Cryogenic centrifugal pumps shall comply with appropriate general standards. The appropriate general standard(s) shall be subject to the particular circumstances and applicable regulations and should be agreed between the manufacturer and the purchaser.

NOTE Commonly used standards are, e.g. ISO 5199, ISO 13709 (ANSI/API 610) or EN 809.

In the event of conflict, the requirements of this International Standard shall take precedence over the general standards.

4.2 Materials

4.2.1 General

Materials of construction shall be selected taking into consideration that cryogenic pumps operate at low temperature, often in a damp environment, and at times with liquid oxygen or flammable fluids.

The minimum requirements given in [4.2.2](#), [4.2.3](#) and [4.2.4](#) shall apply.

4.2.2 Mechanical properties at low temperature

Metallic materials which are under stress at low temperature and which exhibit a ductile/brittle transition (such as ferritic steels) shall have minimum toughness values in accordance with ISO 21028-1 or ISO 21028-2 as appropriate.

Metallic materials which can be shown to have no ductile/brittle transition do not require impact testing.

Non-metallic materials are generally used only for seals or heat barriers. If such materials are to be used for structural parts, the stress levels and material impact values shall be shown to be acceptable for the intended use.

4.2.3 Corrosion resistance

Materials should be resistant to, or protected from, atmospheric corrosion. Where this is not achievable, a suitable corrosion allowance shall be considered.

4.2.4 Oxygen and oxidizing fluids compatibility

If the specified minimum service temperature is equal to or less than the boiling point of air or the pump is intended for oxygen service, the materials which are, or are likely to come, in contact with oxygen or oxygen-enriched air shall be oxygen-compatible in accordance with ISO 21010.

If the pump is employed for oxidizing cryogenic fluids, e.g. nitrous oxide, the requirements for oxygen compatibility should be taken into consideration.

In the case of nitrous oxide, the risk of decomposition shall also be considered.

Materials should be selected that minimize the potential for ignition and inhibit sustained combustion.

Suitable material properties are

- high ignition temperature,
- high thermal conductivity, and
- low heat of combustion.

[Table B.1](#) lists materials found through testing and operating experience to be particularly suitable for centrifugal cryogenic pumps in oxygen service. Materials other than those identified in [Table B.1](#) may be used but their selection shall be justified by specific testing or long-term experience in this application.

For (any) parts of the pump which are, or are likely to come, in contact with oxygen and which could be exposed to energy sources such as friction, aluminium or aluminium alloy including aluminium bronzes containing more than 2,5 % aluminium shall not be used. The use of aluminium or aluminium alloy for any other parts shall only be adopted after careful consideration.

Stainless steel shall not be used for exposed thin components. Exceptions allowed are seal bellows, trapped shims or gaskets and screw-locking devices of stationary parts where knowledge of past satisfactory performance is available. However, suitable alternative materials, e.g. nickel or nickel alloy, Monel^{®1)} and Inconel^{®1)}, should be considered.

NOTE Tin bronze has been found to be most suitable for the main “wetted” pump components. The most common aluminium bronzes, which typically contain between 6 % and 11 % aluminium, have relatively high heats of combustion and, if combustion occurs, are practically impossible to extinguish in an oxygen environment.

1) Monel[®] and Inconel[®] are the trademarks of products supplied by Special Metals Corporation, New Hartford, New York, U.S.A. This information is given for the convenience of users of this International Standard and does not constitute an endorsement by ISO of the product named. Equivalent products may be used if they can be shown to lead to the same results.

4.2.5 Hydrogen compatibility

Consideration should be given to the risk of hydrogen embrittlement when selecting materials and determining stress levels for pumps for liquid hydrogen service; see ISO 21010 and ISO 11114-1, ISO 11114-2, or ISO 11114-4 for guidance.

NOTE Thermal cycling of austenitic stainless steels in the presence of hydrogen might lead to accelerated cracking.

4.3 Design

4.3.1 Pressure-containing parts

The high-pressure side of the pump shall be designed to withstand at least the nominal outlet pressure.

The low-pressure side of the pump shall be designed to withstand at least the maximum inlet pressure +2 bar.

The material stress level from pressure might not be the dominant factor in pump design. The allowable stress level may be calculated at the pressure rating, using ISO 21009-1 for guidance.

4.3.2 Performance

The pump design and installation shall meet the performance requirements specified on the data sheet (or similar document). Examples of a data sheet can be found in ISO 5199 and ISO 9908.

4.3.3 Clearances

Clearances between moving and stationary parts within the pump shall be as large as practical, consistent with good hydraulic performance and sealing. Material selection for components should take into account the often large differences in expansion coefficients to ensure satisfactory clearances and interferences at the operating temperatures and during cool-down.

4.3.4 Prevention of rubbing

The consequences of bearing failure or the consumption of parts by wear shall be considered, particularly in pumps designed for liquid oxygen duty.

4.3.5 Fastenings

All internal fasteners shall be secured to prevent them loosening in service (e.g. friction nuts, tab washers).

Consideration shall be given to more adequately securing items which might normally be held in place by an interference fit only (e.g. wear rings). These components can cool down more quickly than others and become temporarily loose.

4.3.6 Warm bearings

Rolling-element bearings designed to run warm shall be located or protected such that freezing of the lubricating grease or oil is avoided. The effect of ice build-up over a period shall be considered. This can result in overcooling of the bearing and can allow shaft-seal leakage to be forced directly into the driver bearing. Motor-bearing heaters may be considered for cold standby pumps.

4.3.7 Cold bearings

For bearings designed to run cold, lubricated by the cryogenic fluid, the use of materials and design arrangements that can safely withstand short-term dry running shall be considered.

4.3.8 Bearing lubrication

For direct-coupled cryogenic pumps, grease and oils shall be suitable for all oxidizing and predictable offset conditions. The lubricants should typically be suitable down to $-40\text{ }^{\circ}\text{C}$.

Sealed bearings are preferred. Where bearing re-greasing *in situ* is required, grease drain plugs should be provided to reduce the risk of accumulations of grease within the motor housing.

Liquid oxygen pumps shall be constructed so that possible oxygen leakage cannot contact any hydrocarbon lubricant. If this cannot be prevented with certainty, the use of oxygen-compatible lubricants meeting the requirement of ISO 21010 shall be considered. It should be noted, however, that such oxygen-compatible lubricants are less able to protect the bearing against corrosion, generally reduce the ability of the bearing to withstand load and speed, and may have some adverse reaction with some material combinations.

4.3.9 Shaft seals

Shaft seals are usually either mechanical rubbing face or labyrinth type. Both have a high possibility of leakage.

The design of the mechanical seal shall prevent metal-to-metal rubbing between the seal carrier and the rotating seal ring when the soft face material wears out.

For pumps in oxygen service, there shall be no contact between the bellows and the shaft. This can, e.g. be achieved by a protective sleeve between the bellows and the shaft.

Labyrinth shaft seals shall be treated as systems, engineered for the particular application. For pumps in oxygen service, injected gas may be an inert gas or oxygen.

Leakage-detection devices should be considered, e.g. a low-temperature trip.

A slinger or other deflection device shall be used to prevent direct impingement of shaft seal leakage on the driver bearing.

4.3.10 Purging

A tapping for a dry inert gas purge may be used to

- prevent the ingress of moisture (and possibly ice build-up) within the seal area,
- prevent the ingress of moisture into areas using lubricants (oxygen-compatible when required; see [4.2.4](#)), and
- provide a barrier between oxygen-compatible and oxygen-non-compatible parts of a pump (e.g. cold end and mechanical drive).

4.3.11 Prevention of particle contamination

Appropriate devices such as filters shall be used if there is a risk of particle contamination in service.

NOTE For recommended service conditions of filters, see [A.1.10](#).

4.3.12 Specific requirement for flammable liquids

The rate of leakage from the pump and its accessories at any spot shall not exceed $1\text{ mm}^3/\text{s}$, corrected to normal temperature and pressure [$0\text{ }^{\circ}\text{C}$, $1013,25\text{ mbar}$, ($1,01325 \times 10^5\text{ Pa}$)] or 10^{-3} mbar l/s , and its design should prevent the possibility of dangerous fluid accumulations. Methods for leak testing can, e.g. be found in EN 1779. The leakage from any higher flow rates (from seal areas, etc.) shall be collected and vented to a safe location.

If electric devices are used, they shall be suitable for the hazard zone, in accordance with the relevant regulations.

Pumps shall have sufficient electrical continuity to prevent build-up of static electricity.

NOTE For recommended service conditions of filters, see [A.1.10](#).

4.3.13 Protection against over-pressurization

The design of the pump should avoid the possibility of any trapped cryogenic liquid. Any area of the pump or its accessories that could become inadvertently pressurized beyond its design conditions shall be provided with a method of pressure relief, in particular, any vacuum-insulated space that could become pressurized by leakage through a defect.

4.3.14 Pump motors

Externally mounted electric motors shall be the totally enclosed fan-cooled type, for pumps for which the specified minimum temperature is equal to or less than the boiling point of air or the pump is intended for oxygen service.

Hydraulic motors shall be isolated from the cryogenic cabinet.

5 Test procedures

5.1 Prototype testing

5.1.1 General

At least one pump representative of any new pump design shall be subjected to the following tests.

These tests shall be repeated if any one of the following parameters changes:

- manufacturer;
- frame size;
- material type;
- increase in maximum pressure or speed.

5.1.2 Design evaluation

The prototype pump shall be inspected to ensure that the design satisfies the requirements detailed in [Clause 4](#).

5.1.3 Performance evaluation

The performance shall be evaluated according to the requirements of the design standard or ISO 5198.

5.1.4 Initial tests

Before conducting the test according to [5.1.5](#), the pump pressure-retaining envelope (casing flanges, etc.) shall be tested to 1,5 times the outlet and inlet PN.

NOTE Testing is normally to 1,5 times the outlet PN, unless special provision for separately testing the high- and low-pressure sections has been incorporated at the design stage.

The pressure during testing shall be maintained for a sufficient period of time to permit complete examination of parts under pressure. The results of the hydrostatic test shall be considered satisfactory

if, when pressure is held for 5 min, no gross plastic deformation, leaks or seepage (through the casing or casing joint) from the pump is observed.

5.1.5 Cryogenic tests

5.1.5.1 General test conditions

Pumps with a specified minimum service temperature at or higher than -196 °C shall be tested at or below their specified minimum service temperature, $\pm 20\text{ °C}$.

Pumps with a specified minimum service temperature below -196 °C may be tested at a temperature above their minimum service temperature, provided it is not warmer than -196 °C .

A deviation from -196 °C of $\pm 20\text{ °C}$ is allowed in temperature measurement.

If the cryogenic fluid used for testing is different from that specified for final use, density corrections for power, etc. are acceptable.

5.1.5.2 Mechanical integrity test

Centrifugal pumps shall be run at a minimum of five speeds, except for pumps manufactured by constant speed specifications. These shall include minimum, normal and maximum service speeds. (This shall allow a head/flow pump characteristic curve to be generated.) The run at normal service speed shall be at least 1 h duration.

Where pump size and flow rate are large, a reduced test time is acceptable provided required temperatures are reached.

As part of the test, the pump shall be stopped and started a minimum of 10 times.

Throughout the test, the pump shall be seen to run normally with no visible leakage, excessive vibration or distress. For flammable fluids, additional requirements for leak-tightness apply that shall be demonstrated during type testing.

5.1.5.3 Net positive suction head (NPSH) test

The pump shall be tested to establish its NPSH requirement across its range of flow rate.

Following the test, the pump shall be warmed up, disassembled into its major component parts and examined. No significant indications of touching, rubbing or distress shall be observed. (Marking on impeller, labyrinth seal and bushings, etc. is acceptable.)

5.2 Production testing

5.2.1 General

Each pump shall satisfactorily pass the following production tests of the appropriate standards as indicated in [4.1](#).

5.2.2 Hydrostatic pressure test

The pump pressure-retaining envelope (casing, flanges, etc.) shall be tested to 1,5 times the outlet and inlet PN.

NOTE Testing is normally to 1,5 times the outlet PN unless special provision for separately testing the high- and low-pressure sections has been incorporated at the design stage.

The pressure during testing shall be maintained for a sufficient period of time to permit complete examination of parts under pressure. The results of the hydrostatic test shall be considered satisfactory

if, when pressure is held for 5 min, no gross plastic deformation, leaks or seepage (through the casing or casing joint) from the pump is observed.

5.2.3 Mechanical running and performance test

The pump shall be run for a minimum of five minutes at its quoted duty point(s), with cryogenic fluid temperature conditions as stated in [5.1.5](#). Throughout the test, the pump shall be seen to run normally with no visible leakage, excessive vibrations or distress.

Where the cryogenic fluid used on test is different from that specified for final use, density corrections for power, etc. are acceptable.

6 Cleanliness

The pumps shall be dispatched with a cleanliness level and packing integrity which complies with ISO 23208.

7 Marking

The pump body or identification plate shall be marked in accordance with the applicable standard and shall include the fluids for which the pump is suitable.

Marking of the pump shall be visible after installation.

Annex A (informative)

Guidance on installation design

A.1 Pumps for cryogenic service

A.1.1 The following installation design recommendations are given for guidance only and represent good industrial practice.

Alternative methods may be used if they provide equivalent safety.

A.1.2 Suction pipework should be as short and straight as possible with a minimum number of bends. Pipework should be sized, arranged and insulated (if necessary) to ensure that the NPSH requirement for the pump(s) is met at the lowest design tank level and highest flow rate. (NPSH is defined in [3.5](#) but can be regarded as the difference between the heads as measured by a pressure gauge at the pump suction flange and the pressure at which the fluid at the pump suction flange will boil.)

A.1.3 Consideration should be given to the likely behaviour of liquid and vapour during cool-down to avoid gas locking. If gas is to be vented externally during cool-down, consideration should be given to the size of vents and lines and to the safe direction of venting.

A.1.4 If more than one pump is installed, dead-legs should be avoided or minimized by the use of individual lines, isolation valves mounted close to branches, and/or correct use of gaskets.

A.1.5 Pumps should be installed using vibration dampeners/compensators. These should be installed to ensure that high flange loadings are not transmitted on cool-down (e.g. in pre-compressed conditions). Consideration to pipe shrinkage at cool down should be accounted for.

A.1.6 Provision should be made for safe removal of pumps for maintenance. Consideration should be given to the provision of any lifting beams or strong points for lifting equipment and the layout of pipework and cable trays, etc. to maximize access.

A.1.7 The vicinity of cryogenic pumps should be well-ventilated to avoid excessive concentrations of gas in the event of seal leakage or air condensation.

A.1.8 Safety distances from boundaries, pits, drains, etc. should be in accordance with the relevant operational standards for cryogenic vessels.

A.1.9 A non-return valve should be installed in the pump outlet pipework.

A.1.10 The pump should be cooled to an acceptable temperature prior to starting to limit the possibility of cavitation.

A.1.11 Consideration should be given to monitoring for cavitation.

A.2 Additional guidance on installation design for pumps for oxygen service

A.2.1 Oxygen-service pump installations need to be designed and operated taking into account the hazards of oxygen.

Consideration should be given to measures to reduce the likelihood of an incident and to protect personnel in the event of an incident. Guidance can also be found in EIGA/IGC doc. 148/14.

Pumps constructed of suitable materials with attention to the design of the seal and lubrication system have a low probability of ignition.

A.2.2 Valves and controls that need to be manually operated while a pump is running (or likely to run) should be located outside any barrier or have their valve stems protruding through the barrier.

A.2.3 A fail-close emergency shut-off valve (ESOV) should be considered on the suction pipework of oxygen pumps to isolate flow of oxygen in the event of a fire. This valve may be tripped automatically or by an operator pressing a button.

A.2.4 Where pumps share a common suction pipe and the shutdown of all pumps can be tolerated, the installation of one ESOV is acceptable.

A.2.5 If oxygen pumps are kept permanently cold but are not run, high hydrocarbon concentrations resulting from dry vaporization of liquid oxygen should be avoided.

A.2.6 It is recommended that the discharge non-return valve be installed downstream of the first elbow in the delivery line in order to reduce the chance of it becoming inoperative due to fire or debris.

A.2.7 Combustible surfaces, e.g. asphalt or other organic substances, should not be used for pump installation ground surfaces. No combustible materials should be stored locally and the area should be kept free of debris at all times.

A.2.8 A suction filter of suitable material should be installed in the suction line. The open area should be at least 150 % of the cross-sectional area of the pipe bore in order to ensure a low pressure drop. For this reason, a conical filter design is preferred. The filter should be robustly constructed, having a fine mesh adequately supported by a perforated backing plate.

A.2.9 The design and layout of the piping and electrical cabling for oxygen-service installations should consider the possible consequences of an incident involving a fire. Electrical cabling should have sufficient separation from cryogenic pipes.

A.2.10 A loss-of-prime detection system should be installed to stop the pump and prevent dry running (e.g. low differential or discharge pressure, low current or high discharge liquid temperature).

Annex B (informative)

Acceptable materials for construction of centrifugal pumps for liquid oxygen

A list of acceptable materials particularly suitable for centrifugal cryogenic pumps for oxygen service is given in [Table B.1](#). Materials other than those identified in the table may be used for the parts that are not in contact with oxygen or oxygen-enriched air, provided their suitability has been justified by specific testing or long-term experience in this application. Examples of centrifugal pumps are given in [Figures B.1](#) and [B.2](#).

Table B.1 — Acceptable materials (examples) for centrifugal liquid oxygen pumps

No. ^a	Component	Acceptable materials
1 2 3 4 5	Volute or pump-body backplates Impellers Inducers Diffusers Wear rings	Tin bronze or leaded bronze ^b
6	Shafts	Austenitic stainless, martensitic stainless steel ^d , Monel ^{®f}
7	Shaft sleeve (as part of any inter-stage bearing)	Phosphor bronze ^e , stainless steel, Monel ^{®f} , suitable copper alloy ^c
8	Interstage bushings or bearings	Copper alloy ^c , Monel ^{®f} (with or without PTFE coating), PTFE or carbon-based materials that have passed the oxygen compatibility test in ISO 21010
9	Impeller bolt fasteners	Monel ^{®f} , austenitic stainless steel, beryllium copper or copper alloy ^c
10	Tab-lock-washers, shims	Monel ^{®f} , beryllium copper or copper alloy ^c
11	Seals Mechanical seal Rotating ring Bellows Wearing face Labyrinth seal	— Stainless steel, tungsten carbide, stellite or ceramic — Austenitic stainless steel or nickel alloys (if a protective sleeve is used, this shall be copper alloy ^c) — Non-metallic materials that have passed the oxygen compatibility test in ISO 21010 — Tin bronze, Monel ^{®f} , Inconel ^{®f} , stainless steel; non-metallic materials that have passed the oxygen compatibility test in ISO 21010 Stainless steel may be used for one but not for both seal surfaces
12	Gaskets	Filled PTFE, spiral wound metallic gasket type (using Monel ^{®f} or nickel)
13	O-Ring, atmospheric seal	PTFE
14	Slinger or thrower	Material corrosion-resistant and suitable for low-temperature service
15	External pump-body screw, bolt	Material corrosion-resistant and suitable for low-temperature service
16	Carrier frame	Austenitic stainless steel. Material suitable for low-temperature service (see ISO 21028-1)

Table B.1 (continued)

No. ^a	Component	Acceptable materials
17	Thermal barrier	Materials suitable for low-temperature service and that have passed oxygen compatibility test in ISO 21010
18	Filter/strainer	Nickel or nickel alloys (Monel ^{®f}) or copper alloy ^c mesh screen, on a copper alloy ^c or Monel ^{®f} or stainless steel support
<p>^a Corresponding to the element shown in Figures B.1 and B.2.</p> <p>^b Tin bronze and leaded bronze typically have the following compositions:</p> <ul style="list-style-type: none"> — tin bronze: 10 % to 14 % Sn, remainder copper; — leaded bronze: 5 % to 7 % Sn; 5 % to 6 % Pb; 4 % to 5 % Zn. <p>^c Copper alloy typically has the following composition:</p> <ul style="list-style-type: none"> — at least 80 % copper alloy with a combined aluminium and iron content of not more than 3 %. <p>^d The use of martensitic stainless steels requires some special design considerations due to their low impact strength.</p> <p>^e The phosphor bronze may be tungsten carbide or chrome-plated. The stainless steel may be stellited.</p> <p>^f Monel[®] and Inconel[®] are the trademarks of products supplied by Special Metals Corporation, New Hartford, New York, U.S.A. This information is given for the convenience of users of this International Standard and does not constitute an endorsement by ISO of the product named. Equivalent products may be used if they can be shown to lead to the same results.</p>		

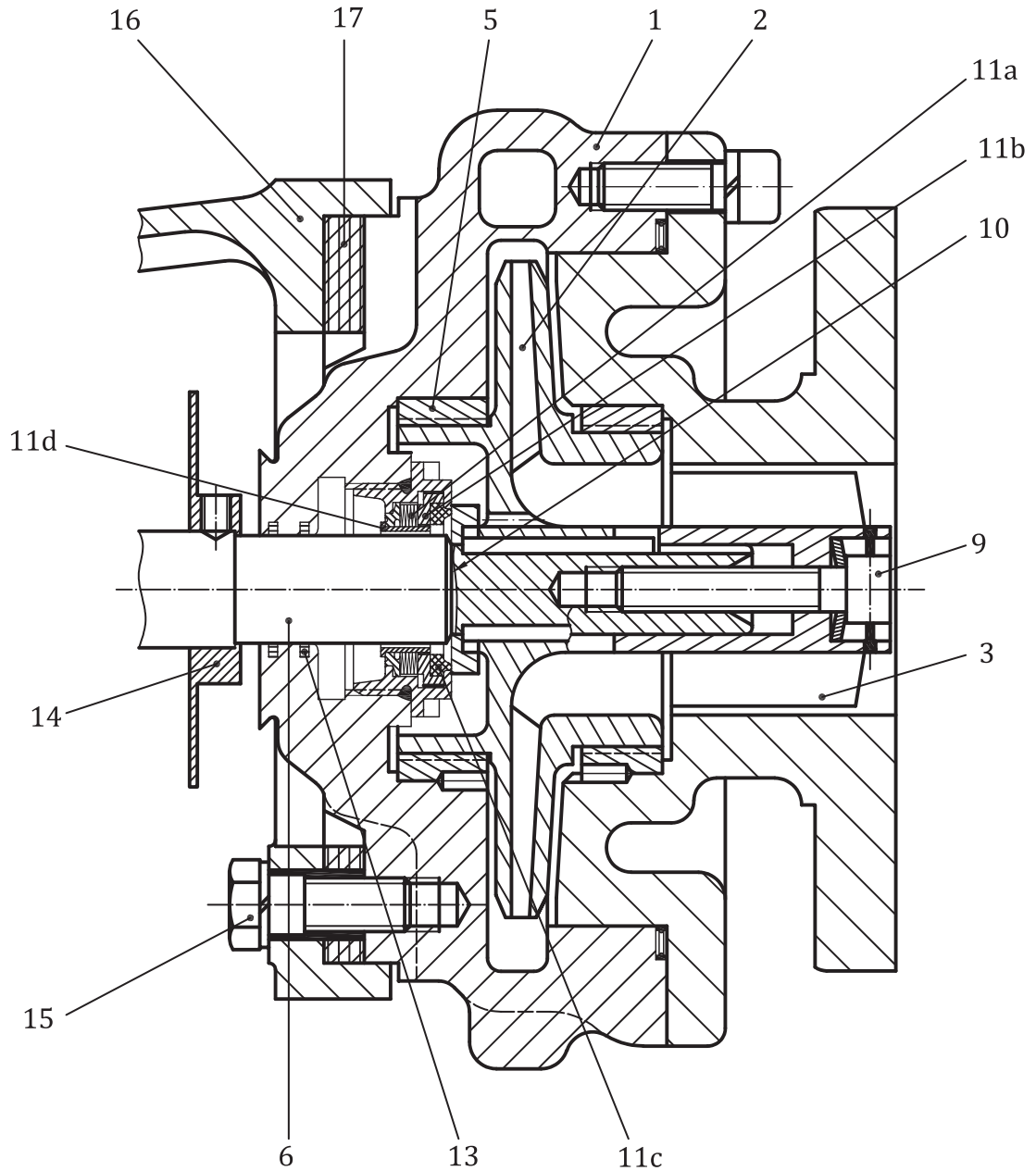

Key

- | | | | | | |
|---|---------------------|-----|---------------------------|----|-----------------|
| 1 | volute or pump body | 10 | shims | 14 | slinger |
| 2 | impellers | 11a | seal bellows | 15 | bolt |
| 3 | inducers | 11b | seal wear face | 16 | carrier frame |
| 5 | wear rings | 11c | seal rotating face | 17 | thermal barrier |
| 6 | pump shaft | 11d | bellows protective sleeve | | |
| 9 | impeller bolts | 13 | atmospheric seal | | |

NOTE Numbers also refer to [Table B.1](#).

Figure B.1 — Single-stage centrifugal pump

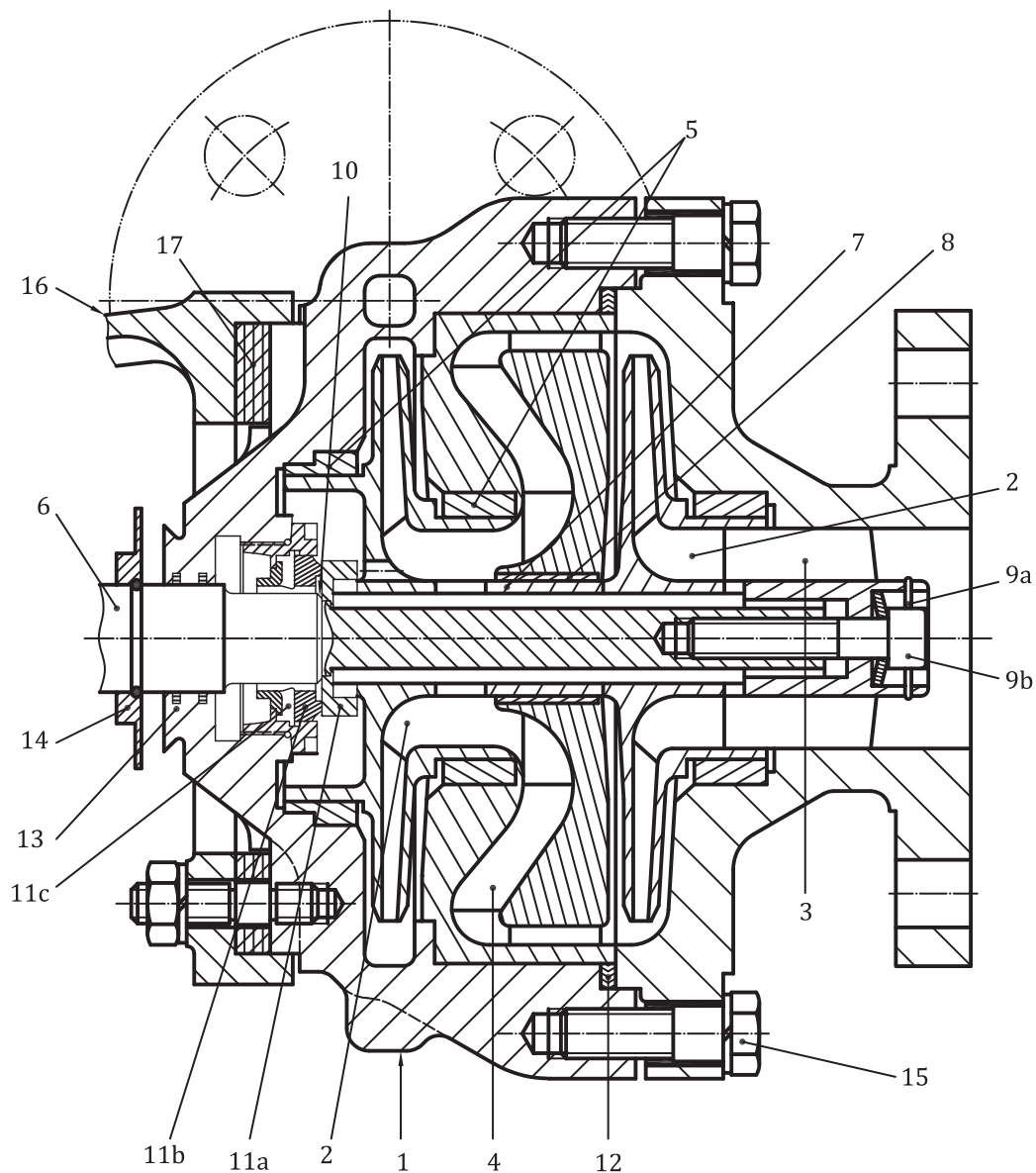

Key

1	volute or pump body	8	interstage bearing	12	gasket
2	impellers	9a	fastener	13	atmospheric seal
3	inducers	9b	impellers bolts	14	slinger
4	diffuser	10	shims	15	body screw
5	wear rings	11a	seal rotating face	16	carrier frame
6	pump shaft	11b	seal bellows	17	thermal barrier
7	shaft sleeve	11c	seal wear face		

NOTE Numbers also refer to [Table B.1](#).

Figure B.2 — Two-stage centrifugal pump

Bibliography

- [1] ISO 5199, *Technical specifications for centrifugal pumps — Class II*
- [2] ISO 6708, *Pipework components — Definition and selection of DN (nominal size)*
- [3] ISO 9908, *Technical specifications for centrifugal pumps — Class III*
- [4] ISO 13709, *Centrifugal pumps for petroleum, petrochemical and natural gas industries*
- [5] ISO 20421-1, *Cryogenic vessels — Large transportable vacuum-insulated vessels — Part 1: Design, fabrication, inspection and testing*
- [6] ISO 21009-1, *Cryogenic vessels — Static vacuum-insulated vessels — Part 1: Design, fabrication, inspection and tests*
- [7] ISO 21029-1, *Cryogenic vessels — Transportable vacuum insulated vessels of not more than 1 000 litres volume — Part 1: Design, fabrication, inspection and tests*
- [8] EN 809, *Pumps and pump units for liquids — Common safety requirements*
- [9] EN 1779, *Non-destructive testing — Leak testing — Criteria for the method and technique selection*
- [10] EIGA/IGC doc. 148/14, *INSTALLATION GUIDE FOR STATIONARY, ELECTRIC-MOTOR-DRIVEN, CENTRIFUGAL LIQUID OXYGEN PUMPS*

