**Fire tests — Open calorimetry —
Measurement of the rate of production of
heat and combustion products for fires of
up to 40 MW**

*Essais au feu — Calorimétrie ouverte — Mesurage de la vitesse de
production de chaleur et de produits de combustion dans le cas de feux
ayant un débit thermique inférieur ou égal à 40 MW*



PDF disclaimer

This PDF file may contain embedded typefaces. In accordance with Adobe's licensing policy, this file may be printed or viewed but shall not be edited unless the typefaces which are embedded are licensed to and installed on the computer performing the editing. In downloading this file, parties accept therein the responsibility of not infringing Adobe's licensing policy. The ISO Central Secretariat accepts no liability in this area.

Adobe is a trademark of Adobe Systems Incorporated.

Details of the software products used to create this PDF file can be found in the General Info relative to the file; the PDF-creation parameters were optimized for printing. Every care has been taken to ensure that the file is suitable for use by ISO member bodies. In the unlikely event that a problem relating to it is found, please inform the Central Secretariat at the address given below.



COPYRIGHT PROTECTED DOCUMENT

© ISO 2008

All rights reserved. Unless otherwise specified, no part of this publication may be reproduced or utilized in any form or by any means, electronic or mechanical, including photocopying and microfilm, without permission in writing from either ISO at the address below or ISO's member body in the country of the requester.

ISO copyright office
Case postale 56 • CH-1211 Geneva 20
Tel. + 41 22 749 01 11
Fax + 41 22 749 09 47
E-mail copyright@iso.org
Web www.iso.org

Published in Switzerland

Contents

Page

1	Scope	1
2	Normative references	1
3	Terms and definitions	2
4	Principle	2
5	Hood and exhaust duct	3
5.1	Requirements of the hood/duct and extraction system	3
5.2	Laboratory requirements	3
6	Instrumentation of the exhaust duct	3
6.1	General	3
6.2	Volume flow rate	3
6.3	Gas temperature	4
6.4	Gas analysis	4
6.5	Optical density	5
7	Additional equipment and procedures	5
7.1	Weigh platform	5
7.2	Heat flux measurements	5
7.3	Data recorder	6
7.4	Timing device	6
8	Heat and smoke release measurement	6
9	Experimental arrangements	6
10	Ignition sources	6
10.1	General	6
10.2	Calibration of gas burners	7
11	System performance	7
11.1	HRR measurement confirmation	7
11.2	System response	8
11.3	Precision	8
12	Reliability of data	8
13	Preparation of test specimens	8
14	Testing	9
14.1	Initial conditions	9
14.2	Procedure	9
15	Test report	10
	Annex A (informative) Design of the hood and exhaust system	11
	Annex B (informative) Instrumentation of the exhaust duct	16
	Annex C (informative) Procedure for checking the stability of the oxygen analyser	18
	Annex D (informative) Light measuring systems	19
	Annex E (informative) Calculations	21
	Annex F (informative) Ignition sources	25

Annex G (normative) Specific procedure for testing upholstered furniture	27
Annex H (informative) Repeatability and reproducibility	29
Bibliography	30

Foreword

ISO (the International Organization for Standardization) is a worldwide federation of national standards bodies (ISO member bodies). The work of preparing International Standards is normally carried out through ISO technical committees. Each member body interested in a subject for which a technical committee has been established has the right to be represented on that committee. International organizations, governmental and non-governmental, in liaison with ISO, also take part in the work. ISO collaborates closely with the International Electrotechnical Commission (IEC) on all matters of electrotechnical standardization.

International Standards are drafted in accordance with the rules given in the ISO/IEC Directives, Part 2.

The main task of technical committees is to prepare International Standards. Draft International Standards adopted by the technical committees are circulated to the member bodies for voting. Publication as an International Standard requires approval by at least 75 % of the member bodies casting a vote.

Attention is drawn to the possibility that some of the elements of this document may be the subject of patent rights. ISO shall not be held responsible for identifying any or all such patent rights.

ISO 24473 was prepared by Technical Committee ISO/TC 92, *Fire safety*, Subcommittee SC 1, *Fire initiation and growth*.

Fire tests — Open calorimetry — Measurement of the rate of production of heat and combustion products for fires of up to 40 MW

WARNING — So that suitable precautions can be taken to safeguard health, the attention of all concerned in fire tests is drawn to the possibility that toxic or harmful gases can be evolved during combustion of test specimens.

The test procedures involve high temperatures. Hazards can therefore exist for burns and ignition of extraneous objects or clothing. The operators should use protective clothing, helmets, face-shields and breathing equipment for avoiding exposure to toxic gases.

Laboratory safety procedures should be set up to ensure the safe termination of tests. Adequate means of extinguishing such a fire must be provided.

Specimen collapse may also occur in the laboratory space. Laboratory safety procedures should be set up to ensure safety of personnel with due consideration to such situations.

1 Scope

This International Standard specifies a series of test methods that simulate a real scale fire on a test object or group of objects under well-ventilated conditions. A range of different fire sizes can be studied according to the scale of the equipment available.

The method is intended to evaluate the contribution to fire growth provided by an object or group of objects using a specified ignition source.

A test performed in accordance with the method specified in this International Standard provides data for all stages of a fire.

NOTE When the data are used in relation to specific situations the effect of the environment, including the effects of feedback and restricted ventilation, needs to be taken into account.

2 Normative references

The following referenced documents are indispensable for the application of this document. For dated references, only the edition cited applies. For undated references, the latest edition of the referenced document (including any amendments) applies.

ISO 5660-1, *Reaction-to-fire tests — Heat release, smoke production and mass loss rate — Part 1: Heat release rate (cone calorimeter method)*

ISO 5725-2, *Accuracy (trueness and precision) of measurement methods and results — Part 2: Basic method for the determination of repeatability and reproducibility of a standard measurement method*

ISO 9705:1993, *Fire tests — Full-scale room test for surface products*

ISO 13784-1, *Reaction-to-fire tests for sandwich panel building systems — Part 1: Test method for small rooms*

ISO 13784-2, *Reaction-to-fire tests for sandwich panel building systems — Part 2: Test method for large rooms*

ISO 13785-1, *Reaction-to-fire tests for façades — Part 1: Intermediate-scale test*

ISO 13943, *Fire safety — Vocabulary*

ISO/TS 14934-1, *Fire tests — Calibration and use of radiometers and heat flux meters — Part 1: General principles*

ISO 14934-2, *Fire tests — Calibration and use of heat flux meters — Part 2: Primary calibration methods*

ISO 14934-3, *Fire tests — Calibration and use of heat flux meters — Part 3: Secondary calibration method*

ISO/TS 14934-4, *Fire tests — Calibration of heat flux meters — Part 4: Guidance on the use of heat flux meters in fire tests*

ISO 19702, *Toxicity testing of fire effluents — Guidance for analysis of gases and vapours in fire effluents using FTIR gas analysis*

EN 13823, *Reaction to fire tests for building products — Building products excluding floorings exposed to the thermal attack by a single burning item*

3 Terms and definitions

For the purposes of this document, the terms and definitions given in ISO 13943 and the following apply.

3.1

assembly

fabrication of materials and/or composites, e.g., sandwich panel systems

3.2

material

single substance or uniformly dispersed mixture, e.g., metal, stone, timber, concrete, mineral fibre or polymers

3.3

product

material, composite or assembly about which information is required

3.4

test specimen

representative piece of the product that is to be tested together with any substrate or treatment

NOTE The test specimen may include an air gap.

4 Principle

The potential for the contribution of a single object or group of objects to the hazard of heat release and spread of fire, without being influenced by the effects of any surrounding structure, is evaluated over the period of combustion using a calorimeter. The rate of heat release of the fire is based on calculation of oxygen consumption.

NOTE 1 Procedures to determine the heat release rate (HRR) based on the rate of production of carbon dioxide, can also be used, but are not covered in this International Standard.

The hazard of reduced visibility is estimated by the measurement of the production of light-obscuring smoke.

The fire growth is visually documented by photographic and/or video recording.

NOTE 2 The procedure can be extended to include measurement of:

- time-related weight loss of the fuel;
- the incident heat flux or surface temperature at positions in the vicinity of the fire, as an indication of the hazard of fire spread to an adjacent object;
- the rate of production of certain gaseous combustion products under well-ventilated conditions, using appropriate analytical procedures for gases, as input to data for studies of toxicological hazards.

5 Hood and exhaust duct

5.1 Requirements of the hood/duct and extraction system

The hood and duct system shall be large enough in terms of the size of the hood and the air throughput of the system to ensure that all the combustion products are collected. It shall be at a height such that the flames do not impinge on the hood itself.

NOTE 1 The principles of the design and operation of a hood and duct system and examples of designs in use are given in Annex A.

The system shall not disturb the fire-induced flow at the fire itself.

NOTE 2 This can be demonstrated by carrying out tests with a gas burner at different flow rates in the proposed operating range to show that the HRR data are independent of the setting of the exhaust system (for example as outlined in 11.3).

5.2 Laboratory requirements

The equipment shall be positioned in a laboratory and placed so as to avoid the effects of reflected radiation from walls and to allow free inflow of air. For fires of up to 1 MW, the open sides of the calorimeter hood shall be at least 2 m from the nearest walls. For larger fires this shall be increased; up to 10 m for fires of 20 MW.

The ambient air temperature in the laboratory shall be recorded at intervals of 3 s or less. This is necessary because the operation of the flow system will cause replacement of a quantity of air within the laboratory in which it is installed.

NOTE The number of air changes per hour will be dependent upon the size of the room and the volume flow rate of the calorimeter. It is necessary to provide adequate ventilation to prevent negative pressure.

6 Instrumentation of the exhaust duct

6.1 General

The following sub-clauses specify minimum requirements for instrumentation in the exhaust duct.

NOTE Additional information and designs can be found in Annex B.

6.2 Volume flow rate

The volume flow rate in the exhaust duct shall be measured to an accuracy of at least $\pm 5\%$.

The response time of the barometric instrument that measures flowrate shall be a maximum of 1 s for a change from 10 % to 90 % of the difference between the initial and final differential pressure.

6.3 Gas temperature

The temperature of the gas in the duct shall be measured using a 1,0 mm to 1,6 mm outside diameter, sheathed thermocouple supported in a position in the vicinity of the bi-directional probe. The thermocouple should not be allowed to disturb the flow pattern around the bi-directional probe.

It is recommended to provide more than one thermocouple in case one should fail during the test.

6.4 Gas analysis

6.4.1 Sampling line

The gas samples shall be taken in the exhaust duct at a position where the combustion products are uniformly mixed and down stream of the flow probe and the temperature probe. The sampling line shall be made from an inert material that will not influence the gas species to be analysed. The gas samples shall be taken across the whole diameter of the duct. If a single sampling point is used, samples shall be taken across the duct at this axial position to demonstrate that the concentration across the duct is within $\pm 2\%$ of the average value as determined by probe traverses. The sample gas shall pass through particulate filters and a cooler, then through a cell containing anhydrous calcium sulfate drying agent, under the influence of an oil-free diaphragm pump, before being distributed to the different analysers.

NOTE An example of an arrangement is given in Figure B.1. One material which can be used to construct the sampling line is PTFE. The ratio of sampled to analysed gas is normally at least 20. However, it is more important that the system be designed as a whole in order to optimise system response as described in 11.2.

6.4.2 Oxygen

The O₂ analyser shall be of the paramagnetic type or equivalent in performance and capable of measuring a range of at least 0 % to 21 % (volume percent) oxygen.

$$\text{volume percent} = \frac{\text{volume of gas} \times 100}{\text{volume of air}}$$

The accuracy of the oxygen measurement shall be $\pm 0,02\%$ by volume oxygen or less (i.e. $\pm 0,002\%$ volume fraction oxygen or less). The noise and drift of the analyser shall be not more than 100 ppm (0,01 % by volume) over a period of 30 min (measured as specified in Annex C). The output from the analyser and the data acquisition system shall have a resolution of 0,01 % by volume oxygen or better. The HRR value is most sensitive to the oxygen measurement, therefore the performance of the oxygen meter shall exceed the overall requirements for system response and accuracy.

6.4.3 Carbon monoxide and carbon dioxide

The gas species shall be measured using analysers with an accuracy of $\pm 0,05\%$ by volume or less (i.e. $\pm 0,0005$ volume fraction or less) for carbon dioxide and $\pm 0,001\%$ by volume or less (i.e. $\pm 0,00001$ volume fraction or less) for carbon monoxide.

The HRR value is also sensitive to the carbon dioxide and carbon monoxide measurements, therefore the performance of the carbon dioxide and carbon monoxide meters shall exceed the overall requirements for system response and accuracy.

6.4.4 Measurement of other combustion gas components

When required by the sponsor or regulator, this shall be carried out for a range of different gaseous components using FTIR spectroscopic techniques described in ISO 19702 or other techniques of gas sampling and analysis.

6.5 Optical density

The optical density of the smoke shall be determined by measuring light obscuration using a white light system or a laser system.

EXAMPLE 1 A white light system could consist of a lamp, lenses, an aperture and a photocell (see Annex D).

For a white light system the detector shall have a spectrally distributed responsivity in agreement with the CIE (Commission Internationale d'Éclairage), $V(\gamma)$ -function, the CIE photopic curves to an accuracy of at least $\pm 5\%$.

EXAMPLE 2 A laser system could be one based on the use of a He-Ne laser light source (see Annex D).

The equipment shall be constructed in such a way as to ensure that soot deposited during the test does not reduce the light transmission by more than 5%. The light beam shall cross the exhaust duct along its diameter at a position where the smoke is homogenous. The detector output shall be demonstrated to be linear within 5% over the range of output to be used.

7 Additional equipment and procedures

7.1 Weigh platform

The electronic output of the weigh platform shall be logged with the same frequency and on the same time base as the other logged data.

The platform shall be sufficiently protected from the fire that the output is unaffected by heat from the fire and shall be capable of retaining all the liquid and solid products of combustion.

NOTE This can be achieved by covering the platform with a sheet of calcium silicate board of at least 12,7 mm thickness supported, if necessary, by a metal framework. If necessary, a shallow metal tray, capable of holding the test arrangement, should also be used.

In order to avoid the effect of an up thrust on the measured weight induced by the fire, the ingress of air below the weigh platform shall be prevented on all four sides by the fitting of low walls (screens).

Each day of testing, the platform shall be checked over the range of weight loss expected using standard weights. The output shall be accurate to 1% of the expected range of mass loss or better.

7.2 Heat flux measurements

7.2.1 General

Measurements of incident heat flux may be made at specific positions in the vicinity of the burning item to provide information on the possibility of ignition of a wall surface or a secondary item.

7.2.2 Specification

The heat flux meter shall be of the Gardon (foil) or the Schmidt-Boelter (thermocouple) type with a design range of about 50 kW m^{-2} . Schmidt-Boelter gauges are recommended when the convective currents are expected to be significant. The target area shall be a flat, black surface having an acceptance angle of 180° . The heat flux meter shall have an accuracy of at least $\pm 3\%$ and a repeatability value within 0,5%. In operation, the meter shall be maintained at a constant temperature (within $\pm 5^\circ\text{C}$) above the dew point of the combustion products.

7.2.3 Calibration

The calibration and use of heat flux meters shall be in accordance with ISO/TS 14934-1, ISO 14934-2, ISO 14934-3 and ISO/TS 14934-4.

NOTE Attention is drawn to the fact that measurements of total heat flux such as those described above will comprise a convective component as well as a radiative component, and the magnitude of the latter will depend on test conditions including geometry. Consequently the results can only be valid in relation to the geometry of the test.

7.3 Data recorder

A data logger capable of recording and storing input data from all instruments at intervals not exceeding 3 s shall be provided, and this frequency shall apply to all logged measurements.

7.4 Timing device

A clock with 1 s divisions or an equivalent timing device shall be provided.

8 Heat and smoke release measurement

The calculation of rate of heat release (HRR) and the rate of smoke production shall be in accordance with the procedures given in Annex E.

NOTE Annex E also contains procedures for the calculation of other parameters.

9 Experimental arrangements

The test item or the test arrangement should be placed centrally below the hood. Items should be positioned as in use. For example, furniture may be placed directly on the floor or on a weigh platform, a television set may be placed on a table, curtains may be hung on a rail and electronic equipment or books may be placed in suitable racks.

A specific procedure for the testing of upholstered furniture is given in Annex G. (It should be noted that other procedures are available using different burners.)

When investigating the fire behaviour of a system, it is critical to understand the contributions of the different components. It may be necessary to conduct heat release rate experiments on the individual components in addition to the entire system.

NOTE Advice on the measurement range of the calorimeter in relation to the size of the fire is given in 5.1 and Annex A. However, it is also necessary to ensure that the maximum heat release rate is not in the lower part of the measuring range of the calorimeter, under which circumstances the uncertainty of measurement would be high (low oxygen depletion). For this reason the ISO 9705 calorimeter system, for example, is unsuitable for measurements on fires with a maximum HRR of less than 50 kW.

10 Ignition sources

10.1 General

The ignition source should be equivalent in size, positioning and heating characteristics (e.g. flame or radiant, luminous flame or premixed flame) to the type of ignition that forms the basis of the hazard examined.

Information on ignition sources detailed in existing standards and the use of ignition sources are given in Annex F.

The position of the heat source in relation to the test specimen shall be recorded.

Baseline HRR measurements for the ignition source shall be collected.

For gas burner sources, the heat of combustion of the gas from the local supply shall be known, as well as the uncertainty of the measurement. The gas flow to the burner shall be controlled with an accuracy of at least $\pm 3\%$. The heat output from the burner shall be controlled within $\pm 5\%$ of the prescribed value.

WARNING — The operating of gas burners should only be carried out with the appropriate safety precautions.

10.2 Calibration of gas burners

The calibration of a mass flow controller shall be renewed at least annually. Alternatively, the system shall be checked at least bi-annually by one of the following methods, giving agreement to within 2 %.

- 1) Use of “in-line” wet or dry calibrated gas meter.
- 2) Mass loss of gas from liquid supply tank (with vaporizer) or from cylinders.

NOTE This requires a suitable system for weighing the gas supply and a flexible connection between the gas supply and the metering system. The influence of the flexible connection on the mass change needs to be negligible and it is recognised that the method may not be suitable in all cases. It is necessary to demonstrate that the mass loss equals the fuel burning rate and no procedure is at present available for doing this.

The safety aspects of this procedure need to be considered as, in some countries, flexible connections may not be used and the gas container will need to be disconnected for weighing.

11 System performance

11.1 HRR measurement confirmation

An HRR measurement confirmation test shall be performed prior to each test or continuous series of tests.

NOTE 1 The calculation procedures required are given in Annex E.

NOTE 2 When operating a calorimeter in which flowrate is determined using an orifice plate device, the results of a test of this type are often used to derive the orifice plate constant, and in such cases cannot be used to confirm the HRR measurement.

For calorimeter installations conforming to ISO 9705, the confirmation test shall be performed with the burner heat outputs given in Table 1, with the burner positioned directly under the hood of the calorimeter. Measurements shall be taken at least every 3 s and shall be started 1 min prior to ignition of the burner.

For other installations, the measurements shall be made in the same way, but the higher level of HRR should be at least 30 % of the range of HRR for which data are to be used and the lower level shall be one third of the higher level.

At steady state conditions, the difference between the mean heat release rate over 1 min, calculated from the measured oxygen consumption and that calculated from the metered gas input shall not exceed 10 % for each level of heat output.

Table 1 — Burner heat output profile for ISO/TR 9705-2 calorimeter

Time min	Heat output kW
0 to 2	0
2 to 7	100
7 to 12	300
12 to 17	100
17 to 19	0

NOTE HRR measurement confirmation at higher levels can be performed to decrease the measuring uncertainty. This can be carried out using gas burners, liquid pool fires or liquid spray burners (Reference [5]). A suitable burner and metering system using natural gas and capable of being used for fires of up to 6 MW has been described (Reference [6]). As an example of a liquid fuel pool fire, methanol or *n*-heptane is burned in a flat stainless steel container of a suitable size. For pool fires a comparison should be made of the measured net effective heat of combustion measured over the period from ignition to flame-out with a published value for the same fuel (methanol 19,94 MJ/kg, heptane 44,56 MJ/kg) (Reference [7]). For methyl alcohol, a combustion efficiency of 96 % should be used.

11.2 System response

The “delay time”, the “response time” and the “duct flow time” are based on the signals from the oxygen and carbon dioxide analysers and the duct temperature measuring instrument, and shall be calculated from the step change data obtained in the test described in 11.1.

The delay time for any step shall be taken as the difference between the time at which the duct gas temperature changes by 2,5 °C and the time when the oxygen mole fraction has changed by 0,000 5 or the carbon dioxide mole fraction has changed by 0,000 2. For the first step change from low to high level, this shall be 30 s or less for both analysers. These delay times shall be used to correct all test data (see E.2.2).

The response time of the oxygen or carbon dioxide gas analyser shall be taken as the time taken during any step in the system check between a 10 % and 90 % response to the change being made. For the first step change from low to high level this shall be 15 s or less for both analysers.

The duct flow time shall be taken as the difference between the observed time of ignition and an increase of 2,5 °C in the duct gas temperature. This shall be used to correct all data in relation to the start of the test (see E.2.2). For the first step change from low to high level, it shall be 9 s or less.

The time for a 90 % step change in the fuel supply shall be 2 s or less.

NOTE Fast radiometers around the heat source are independent measures of the step change.

11.3 Precision

The system shall be checked at various volume flow rates by increasing the volume flow in the exhaust duct in four equal steps, over the range of flow settings to be used [for an ISO 9705 installation these steps shall be from 2 m² s⁻¹ (at 0,1 MPa and 25 °C) up to the maximum]. The heat output from the burner shall be the higher level used in 11.1. The discrepancy in the mean heat release rate, calculated over 1 min, shall be not more than 10 % of the actual heat output from the burner.

12 Reliability of data

This is discussed in Annex H.

13 Preparation of test specimens

13.1 The product to be tested shall, as far as possible, be placed in the same way as in practical use.

13.2 Unless hygroscopic, specimens shall be conditioned to equilibrium in an atmosphere of (50 ± 5) % relative humidity at a temperature of (23 ± 2) %. Equilibrium shall be deemed to be reached when the item has achieved constant mass.

Constant mass is considered to be reached when two successive weighing operations, carried out at an interval of 24 h, do not differ by more than 0,1 % of the mass of the test piece or 0,1 g, whichever is the greater.

13.3 Full details of the test specimen shall be obtained (and those of any secondary items), including composition, dimensions, manufacturer and manufacturer's model number and reference. If relevant, details of component parts shall also be given.

NOTE In the case of furniture this includes the mass, composition and constructional details of the cover, the interliner (if any), the filling material and the framework.

14 Testing

14.1 Initial conditions

14.1.1 The temperature in the test facility at the start of the test shall be between 10 °C and 30 °C.

14.1.2 The horizontal wind speed measured at a horizontal distance of 1 m from the specimen shall not exceed $0,5 \text{ m s}^{-1}$.

14.1.3 The ignition source shall be placed in the required position. Full details of the geometry of the test set-up shall be recorded.

14.1.4 The test arrangement shall be assembled centrally under the hood of the calorimeter.

14.1.5 The test arrangement shall be photographed or video recorded prior to testing.

14.2 Procedure

14.2.1 Start all recording and measuring devices and record data for at least 2 min prior to ignition of the burner.

14.2.2 Ignite the burner and adjust it to the required output levels. Adjust the exhaust capacity so that all combustion products are collected. Changes should be made slowly to avoid adverse effects on the delay times.

14.2.3 Make a photographic and/or video recording of the test. A clock shall appear in all photographic records, giving time to the nearest 1 s.

14.2.4 During the test, make a record of observations and the times when they occur.

14.2.5 End the test when the combustion has become insignificant, and normally after 30 min if no significant combustion has developed. A decision to continue beyond this time should only be made if it is expected that the effects of instrument drift are insignificant and that the final conditions (see 14.2.8) can be met.

14.2.6 The test may need to be terminated earlier if structural collapse or other conditions develop which are potentially dangerous to the laboratory staff. Continue observation until signs of visual combustion have ceased or the test is ended.

14.2.7 Report the extent of damage of the product after the test.

14.2.8 After extinction of the fire and/or removal of the test materials and debris, the final oxygen analyser and carbon dioxide analyser readings should be within 0,02 % by volume (0,000 2 volume fraction) of the initial values and the light meter attenuation shall be less than 2 % of full range. If this is not the case, it should be reported in the test report and an error analysis should be conducted. In certain cases the data can be invalid.

For some large scale tests it may not be practical to extinguish and remove the residues in a short time at the end of a test and in such cases the reasons for omitting this procedure should be reported.

14.2.9 Record any other unusual behaviour.

15 Test report

The test report shall contain the following information:

- a) name and address of the testing laboratory;
- b) date and identification number of the report;
- c) name and address of the sponsor;
- d) purpose of the test;
- e) method of sampling;
- f) name and address of manufacturer or supplier of the product;
- g) name or other identification marks and description of the product;
- h) construction and installation details of the product:
 - 1) drawings;
 - 2) descriptions;
 - 3) assembly instructions;
 - 4) specification of materials of construction;
 - 5) details of the joints and fixings;
- i) date of supply of the product;
- j) date of test;
- k) test method used and reference to this International Standard, i.e., ISO 24473:2008;
- l) conditioning of the test specimen, environmental data during the test (temperature, atmospheric pressure, relative humidity, etc.);
- m) deviations from the test method, if any;
- n) test results:
 - 1) observations during and after the test;
 - 2) the graphical output of time/volume flow in the exhaust duct (optional);
 - 3) the graphical output of time/rate of total heat release and time/heat release from the burner;
 - 4) the graphical output of time/production of carbon monoxide at reference temperature and pressure (optional);
 - 5) the graphical output of time/production of carbon dioxide at reference temperature and pressure (optional);
 - 6) the graphical output of time/rate of mass loss (if carried out);
 - 7) the graphical output of time/production of light-obscuring smoke at actual duct flow temperature.

Annex A (informative)

Design of the hood and exhaust system

A.1 Design and operation of a full-scale hood and duct system for open calorimetry¹⁾

The hood, duct and exhaust system are the basis of the calorimeter and the size of these depends on the size of the fire being studied. In general, the same instrumentation set can be used for any level of measurement. The straight section of the exhaust duct in front of the measuring section (the section containing the pressure probe, thermocouple, sampling tube and light measurement system) should be at least ten duct diameters in length in order to achieve effective mixing of the combustion products. In order to ensure a more uniform flow profile across the duct, it is also necessary to continue the straight section of the duct for up to five duct diameters beyond the measuring section of the duct and before the extraction fan.

In a most accurate mode of operation, the mean reach of the flames should not extend above the inlet plane of the hood. Experience has shown that, in this mode, the calorimeter does not affect the yield of fire products. In a less accurate mode of operation, flames are allowed to extend above the inlet plane of the hood and it is then possible to measure higher heat release rates with the calorimeter without much loss in accuracy, at least for combustibles with fairly high combustion efficiency. However, in this mode concentrations of fire gases associated with incomplete combustion, such as CO, have been seen to increase. It should be noted that fitting extensions to the hood may not be good practice if their presence encourages conducting test fires so large that smoke descends into the extension region.

The volume of the hood should be as small as possible in order to minimize the “hold-up” of combustion gases in the hood, which produces a time lag and smear in gas concentrations reaching the calorimeter analysis station. However, the inlet area must be large enough to collect the plume gases. A conical hood is much preferred to other designs. For an arbitrary calorimeter capacity Q , in kilowatts, a near-optimum inlet diameter of a conical hood (or inlet side of a box hood) can be scaled according to:

$$\text{Inlet diameter (metres)} = [\dot{Q}/20\,000]^{2/5} \times 10,7 \quad (\text{A.1})$$

The clearance of the rim of the inlet cone above the base of the combustible (which may or may not be at the floor of the test building) should be at least as large as the greatest expected flame height. If this is not known, the clearance height can be scaled according to:

$$\text{Clearance height (m)} = [\dot{Q}/20\,000]^{2/5} \times 11,3 \quad (\text{A.2})$$

It is normally necessary to use a hood of fixed height and this recommendation may not therefore be achieved without the use of staging.

In the “less accurate mode”, with flames reaching the top of the hood, heat release rates considerably greater than the nominal calorimeter capacity (“most accurate mode”) can be accommodated, perhaps by a factor of two.

The duct flow rate should be large enough to limit the temperature rise (from ambient) in the duct to a reasonable value for the design capacity, suggested as 105 K. This insures that operation in the “less accurate mode,” with flames reaching the top of the hood, does not lead to excessive temperature rise, which should remain within 210 K. The maximum required duct flow can be scaled from:

$$\text{Maximum duct flow (kilograms per second)} = [\dot{Q}/20\,000] \times 136 \quad (\text{A.3})$$

1) Information supplied by G. Heskestad, FM Global.

The duct diameter should be small enough to create sufficiently high duct velocities to prevent temperature stratification in the duct, yet not so small that pressure drops are excessive. Duct diameters can be scaled (corresponding to a cold velocity of 15,6 m/s) from:

$$\text{Duct diameter (metres)} = [\dot{Q}/20\,000]^{1/2} \times 3,05 \quad (\text{A.4})$$

A.2 Existing designs of hood/duct system

A.2.1 General

Information on some large calorimeters currently in use is given in Table A.1. (These may not have been built using the design guidelines referred to in Clause A.1.)

Table A.1 — Details of existing large calorimeter installations in use

Duct shape	Diameter of duct (m)	Method of flow measurement	Maximum flow rate (m ³ s ⁻¹)	Shape of hood opening	Description of hood opening	Height of hood opening above ground (m)
Circular	1,4	Bi-directional probe/profile ^a	43	Square	9 m × 9 m sides	5
Circular	1,0	Bi-directional probe/profile ^a	20	Conical	6 m diameter	8 to 12 (variable)
Circular	1,52	6 bi-directional probes	No data	Rectangular	9 m × 12 m sides	3
Circular	3,08	4 pitot tubes ^b	108	Conical	9,24 m diameter	9,24

^a Single probe + flow profile data.

^b Probes equally spaced on circle at 2/3 radius normal to flow with a wall static pressure tap.

A.2.2 Details of the hood and duct system of the ISO 9705 calorimeter

Dimensions in millimetres

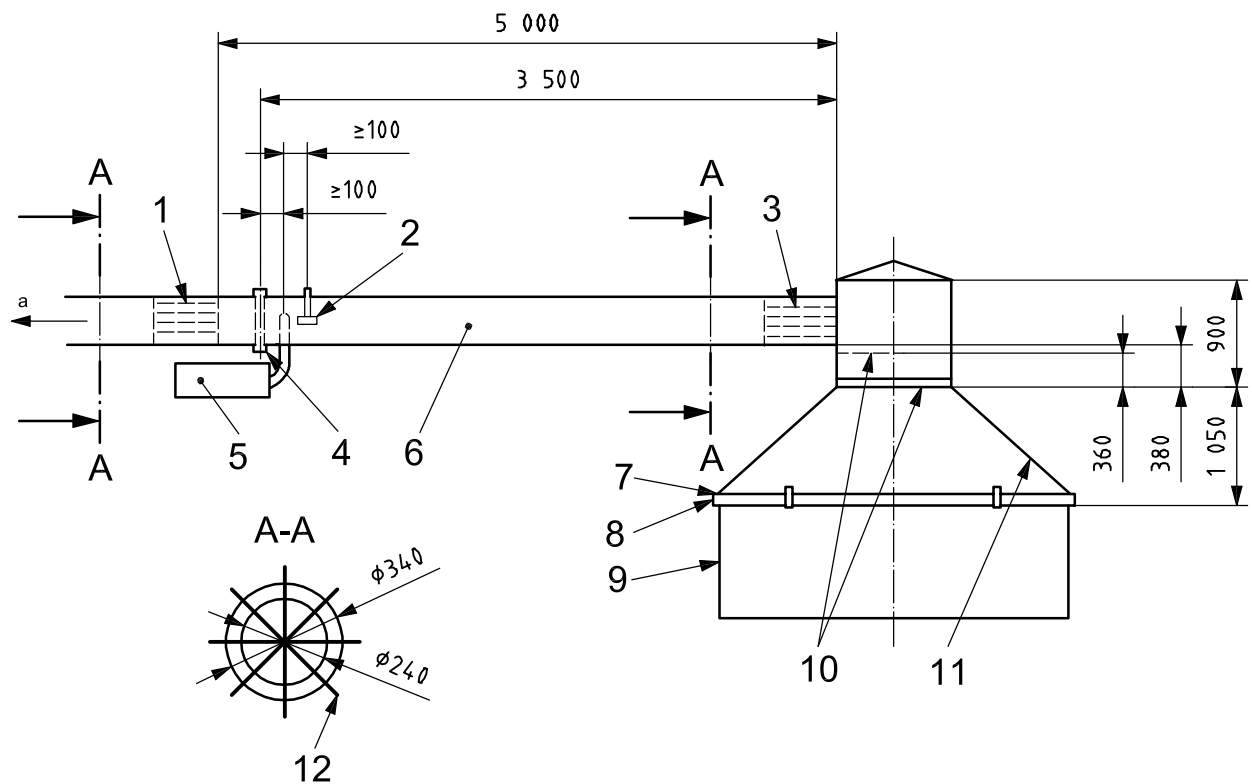
**Key**

- 1 guide vanes
- 2 bi-directional probe
- 3 guide vanes
- 4 lamp, photocell system
- 5 gas analysis
- 6 exhaust duct \varnothing 400 mm
- 7 opening 3 000 mm \times 3 000 mm
- 8 frame of steel profile 50 mm \times 100 mm \times 3,2 mm
- 9 steel plates 1 000 mm \times 3 000 mm
- 10 steel plates 2 mm \times 500 mm \times 900 mm
- 11 hood of 2 mm thick steel plates
- 12 four steel plates 395 mm \times 400 mm

^a To exhaust gas cleaning.

Figure A.1 — Schematic diagram of the exhaust system and location of sampling probes for the ISO 9705 calorimeter

The ISO 9705 system uses a full-scale calorimeter that has been standardized. It comprises a duct of diameter 0,4 m and a hood with a 3 m \times 3 m square opening connected by a mixing chamber. The mixing chamber is not essential for open calorimetry tests (but is necessary for room tests). It has been found to be suitable for studying the burning behaviour of medium sized objects such as furniture and sections of construction with a maximum heat release of between 1 MW and 2 MW. It should be noted that, in accordance with Clause A.1, an exhaust duct flow rate of 6,8 m³s⁻¹ would be required for the most accurate measurements at a level of 1 MW. This is almost twice that required in the standard itself (3,5 m³s⁻¹).

A.2.3 Details of a 7,5 MW calorimeter installation (Reference [8])

Dimensions in metres

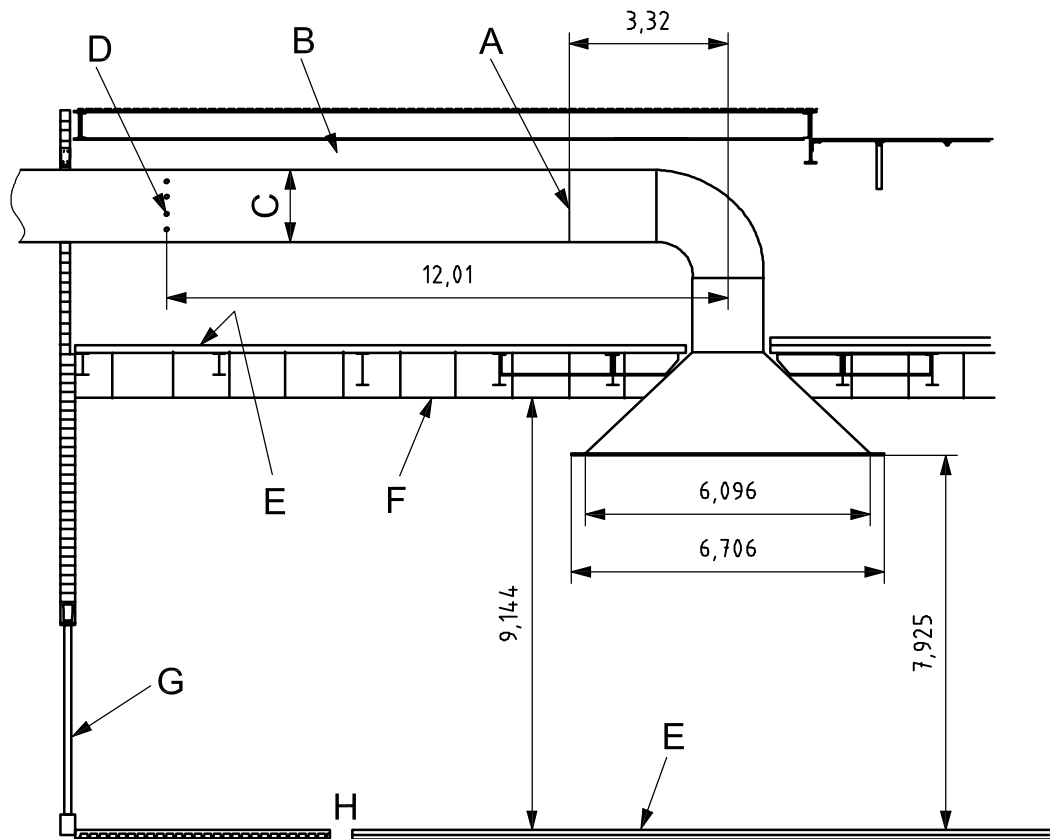

Key

- A 0,884 m diameter orifice.
- B Laboratory attic space.
- C 1,524 m diameter duct.
- D Calorimeter station.
- E Poured concrete floor.
- F Suspended ceiling.
- G Air inlet louvers.
- H Calorimetry laboratory space.

Figure A.2 — Schematic diagram of a 7,5 MW calorimeter

The fire calorimeter, consists of a collection cone of 304 stainless steel, 6,096 m in diameter at its lowest point, which is 7,925 m above the concrete floor of the laboratory. Attached to the top of the cone is a 1,524 m inner diameter 304 stainless steel duct, which elbows from the cone and eventually joins into the exhaust duct. An orifice plate with an inner diameter of 884 mm is located 3,32 m or 2,18 duct diameters from the centre line of the cone in the horizontal section of the duct. The calorimetry instrumentation station for measurements is in the horizontal section of the calorimeter exhaust duct, 12,01 m from the centre line of the calorimeter cone and 8,69 m, or 5,7 duct diameters from the orifice plate. The flow of air through the calorimeter is controlled by a variable damper, located in the exhaust duct, and is capable of maintaining (through a control feedback loop) a constant mass flow of combustion air. The range of air flow through the calorimeter (under cold-flow conditions) is $6 \text{ m}^3\text{s}^{-1}$ to $28 \text{ m}^3\text{s}^{-1}$.

A.3 Intermediate and laboratory scale measurements

The same general principles of design apply and some examples of installations that have been standardized are given in Table A.2 and compared with ISO 9705.

Table A.2 — Measuring range of some standard calorimeter designs

Test standard	Range of HRR measurement
ISO 9705	0 to 1,5 MW
EN 13823	0 to 300 MW
ISO 5660-1	0 to 10 MW

Annex B (informative)

Instrumentation of the exhaust duct

B.1 General

An example from ISO 9705, showing the location of the instrumentation, is given in Figure A.1. In this design a bi-directional probe is used to obtain data for the determination of instantaneous gas flow. As the gas flow cannot be relied upon to be uniform across the duct, it is necessary to apply a correction, k_t , to this measurement based on flow profile measurements as described in Annex E, in order to obtain the averaged flow. For large exhaust ducts, multiple probes positioned in concentric equal areas of the cross section or equally spaced on a circle may also be used to obtain the averaged flow rate (see Clause A.2). These probes can also be impact probes other than bi-directional probes, since the flow direction is relatively constant in the exhaust duct, but the bi-directional probe is recommended over other impact probes because of its reduced susceptibility to blockage.

An alternative method of flow rate measurement is the use of an orifice plate. This is normally positioned at some distance downstream from the exhaust fan in the calorimeter duct, at least 350 mm in the case of the cone calorimeter test (see ISO 5660-1), which uses this method.

B.2 Sampling line

An example of a sample line arrangement is given in Figure B.1.

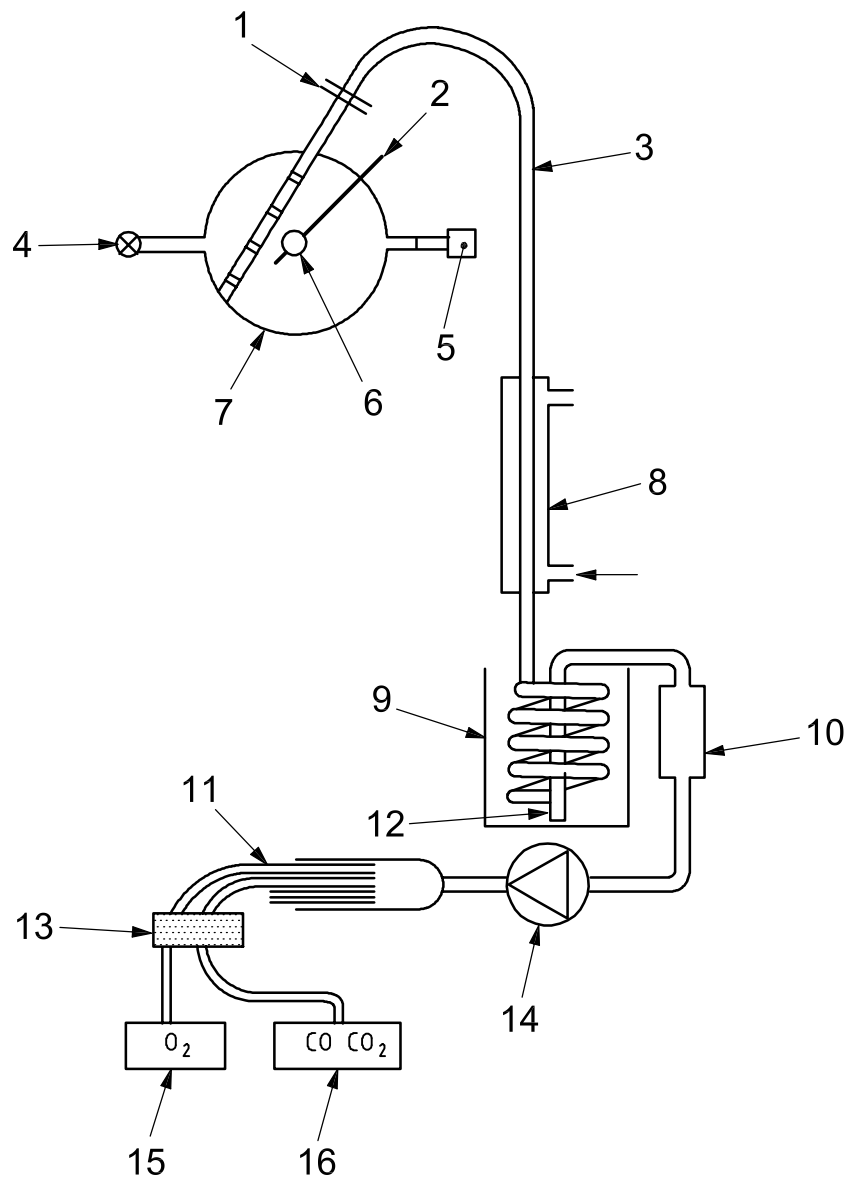
**Key**

- 1 glass filters 150 m to 200 m
- 2 thermocouple
- 3 stainless steel sample line
- 4 light source
- 5 photocell
- 6 bi-directional probe
- 7 exhaust duct
- 8 water cooler
- 9 refrigeration unit
- 10 membrane filter, 3 μm
- 11 surplus gas
- 12 water drainage
- 13 water absorption filter
- 14 membrane pump
- 15 paramagnetic analyser
- 16 infra red spectrometer

Figure B.1 — An example of a sample line arrangement

Annex C (informative)

Procedure for checking the stability of the oxygen analyser

The stability of the oxygen analyser output using the data acquisition system shall be checked after set up, maintenance, repair or replacement of the oxygen analyser or other major components of the gas analysis system and at least every six months.

The procedure for checking the stability of the oxygen analyser output shall be as follows.

- a) Feed the oxygen analyser with oxygen-free nitrogen gas, until the analyser reaches equilibrium.
- b) After at least 60 min in oxygen-free conditions, adjust the volume flow in the exhaust duct to the normal operating level and switch to air from the exhaust duct with the same flow rate, pressure and drying procedure used in the zero and span gas operations for the analyser. When the analyser reaches equilibrium, adjust the analyser output to $(20,95 \pm 0,01)$ % by volume (i.e. $0,209\ 5 \pm 0,000\ 1$ % volume fraction).
- c) Within 1 min, start recording the oxygen analyser output at intervals of 3 s for a period of 30 min.
- d) Determine the drift by use of the least squares fitting procedure to fit a straight line through the data points. The absolute value of the difference between the readings at 0 min and at 30 min of this linear trend line represents the drift.
- e) Determine the noise by computing the root-mean-square (RMS) deviation around the linear trend-line.

The sum of drift and noise (both taken as positive values) shall not be more than 0,01 % by volume oxygen (i.e. 0,000 1 % volume fraction).

Annex D (informative)

Light measuring systems

D.1 Methods

The optical density of the smoke is determined by measuring the light obscuration with an incandescent lamp photometer system or a laser photometer system.

D.2 White light system — Incandescent lamp photometer

The lamp should be of the incandescent filament type and should operate at a colour temperature of $(2\,900 \pm 100)$ K. The lamp should be supplied with stabilized direct current, stable within $\pm 0,2\%$ (including temperature, short-term and long-term stability). The lens system should align the light to a parallel beam with a diameter, D of at least 20 mm. The aperture should be placed at the focus of the lens, L_2 as shown in Figure D.1 and it should have a diameter, d , chosen with regard to the focal length, f , of L_2 so that d/f is less than 0,04.

The detector output should be linear within 5 % over an output range of at least 2 decades.

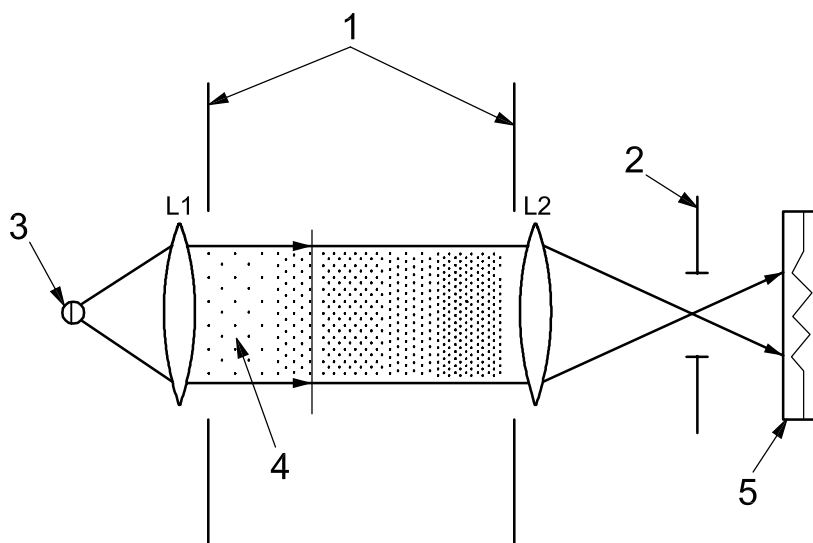

Key

- 1 wall of exhaust duct
- 2 aperture
- 3 lamp
- 4 smoke particles
- 5 detector

Figure D.1 — White light optical system

D.3 Laser system

A laser photometer should use a helium-neon (He-Ne) laser with a power output of 0,5 mW to 2,0 mW. The laser radiation should be polarized. Figure D.2 shows the general arrangements of a laser photometer. Two

silicon photodiodes are provided: a main beam detector and a compensation detector. The electronics should be arranged so as to provide a signal output, which is the ratio of the main beam detector to the compensation beam detector signals.

The system contains two holders for filters: one filter for checking the optical calibration and one filter (located directly after the laser) for checking the proper functioning of the compensation. Calibration filters should be of the type that is a uniform dispersion in glass. Film-coated filters (“interference filters”) should not be used.

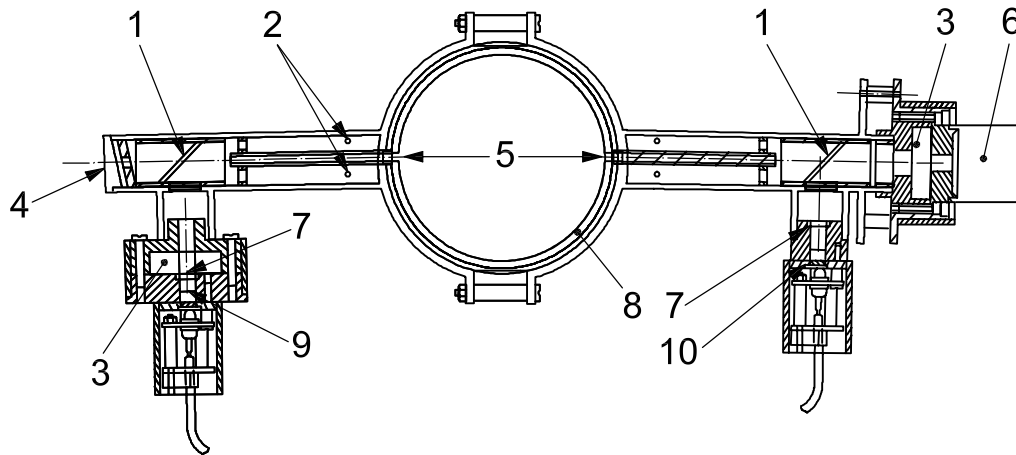

Key

- 1 beam splitter
- 2 purge air orifices
- 3 filter slot
- 4 cap
- 5 optical path
- 6 He-Ne laser beam (0,5 mW)
- 7 opal glass
- 8 ceramic fibre packing
- 9 main detector
- 10 compensation detector

Figure D.2 — Laser-based system for measurement of smoke obscuration

Annex E (informative)

Calculations

E.1 Volume flow

When a bi-directional probe is used, the volume flow in the exhaust duct, \dot{V}_{298} , expressed in cubic metres per second, related to atmospheric pressure and an ambient temperature of 25 °C, should be calculated using Equation (E.1).

$$\dot{V}_{298} = (Ak_v k_p) \times \frac{1}{\rho_{298}} \times (2\Delta\rho T_o \rho_o / T_s)^{1/2} = 22,4 (Ak_t / k_p) (\Delta\rho / T_s)^{1/2} \quad (\text{E.1})$$

where

T_s is the gas temperature in the exhaust duct, expressed in kelvin (K);

$T_o = 273,15$ K;

$\Delta\rho$ is the pressure difference measured by the bi-directional probe, expressed in pascals (Pa);

ρ_{298} is the air density at 25 °C and atmospheric pressure, expressed in kilograms per cubic metre (kg m^{-3});

ρ_o is the air density at 0 °C and 0,1 MPa, expressed in kilograms per cubic metre (kg m^{-3});

A is the cross-sectional area of exhaust duct, expressed in square metres (m^2);

k_t is the ratio of the average mass flow per unit area to mass flow per unit area in the centre of the exhaust duct;

k_p is the Reynolds number correction for the bi-directional probe, taken as constant and equal to 1,08.

When an orifice plate is used to measure flow rate, the volume flow rate, \dot{V}_{298} , expressed in cubic metres per second, related to atmospheric pressure and an ambient temperature of 25 °C, should be calculated using Equation (E.2).

$$\dot{V}_{298} = C(\Delta p / T_s)^{1/2} \quad (\text{E.2})$$

where

Δp is the pressure difference measured by the micromanometer, expressed in pascals (Pa);

T_s is the gas temperature in the exhaust duct, expressed in kelvin (K);

C is the orifice constant determined as described below.

Equation (E.1) assumes that density changes in the combustion gases (related to air) are caused solely by the temperature increase. Corrections due to a changed chemical composition or humidity content may be ignored except in studies of the extinguishment process with water.

The calibration constant k_t should be determined by measuring the flow profile inside the exhaust duct along a cross-sectional diameter. Several series of measurements should be made with representative mass flows and under ambient temperature conditions.

An alternative approach (Reference [6]) is to average the results of measurements using several bi-directional probes placed so as to measure the flow in different and equal concentric areas of the duct cross section.

E.2 Heat release rate measurement confirmation and test process

E.2.1 During the HRR measurement confirmation test where a gas burner is used, heat release rate from the ignition source, \dot{q}_b , expressed in kilowatts, should be calculated from the consumption of gas using Equation (E.3).

$$\dot{q}_b = \dot{m}_b \Delta h_{c,eff} \quad (E.3)$$

where

\dot{m}_b is the mass flow rate of the burner gas, expressed in grams per second (g s^{-1});

$\Delta h_{c,eff}$ is the effective lower heat combustion of the gas used in the burner, expressed in kilojoules per gram (kJ g^{-1});

$\Delta h_{c,eff}$ should be set equal to $46,4 \text{ kJ g}^{-1}$ for propane. (This assumes a combustion efficiency of 100 %.) For a mixed gas, the calorific value should be obtained from the local supplier.

E.2.2 Heat release rate from a tested product \dot{q}_b expressed in kilowatts, should be calculated using Equation (E.4).

$$\dot{q}_b = E^1 \dot{V}_{298} x_{O_2}^a \left(\frac{\phi}{\phi(a-1+1)} \right) - \frac{E^1}{E_{bg}} \dot{q}_b \quad (E.4)$$

with ϕ , the oxygen depletion factor, given by

$$\phi = \frac{x_{O_2}^0(1 - x_{CO_2}) - x_{O_2}(1 - x_{CO_2}^0)}{x_{O_2}^0(1 - x_{CO_2} - x_{O_2})} \quad (E.5)$$

and $x_{O_2}^a$, the ambient mole fraction of oxygen, given by

$$x_{O_2}^a = x_{O_2}^0(1 - x_{H_2O}^a) \quad (E.6)$$

and $x_{H_2O}^a$ given by (Reference [7])

$$x_{H_2O}^a = \frac{H}{100p} \times \exp \left[23,2 - \left(\frac{3816}{T_s} \right) \right] \quad (E.7)$$

where

E is the heat release per volume of oxygen consumed, expressed in kilojoules per cubic metre (kJ m^{-3});

$E^1 = 17,2 \times 10^3 \text{ kJ m}^{-3}$ (25°C) for combustion of tested product;

E_{bg} is the heat release per volume of oxygen consumed, expressed in kilojoules per cubic metre (kJ m^{-3}) of the burner gas. [$E_{bg} = 16,8 \times 10^3 \text{ kJ m}^{-3}$ (25°C) for combustion of propane];

\dot{V}_{298} is the volume flowrate of gas in the exhaust duct at atmospheric pressure and 25°C calculated as specified in Equation (E.1), expressed in cubic metres per second ($\text{m}^3 \text{ s}^{-1}$);

α is the expansion factor due to chemical reaction of the air that is depleted of its oxygen ($= 1,105$ for combustion of tested product);

$x_{\text{O}_2}^{\text{a}}$ is the ambient mole fraction of oxygen including water vapour;

NOTE $x_{\text{O}_2}^{\text{a}}$ should be calculated using Equation (E.6).

$x_{\text{O}_2}^0$ is the initial value of oxygen analyser reading, expressed as a mole fraction;

x_{O_2} is the oxygen analyser reading during test, expressed as a mole fraction;

$x_{\text{CO}_2}^0$ is the initial value of carbon dioxide analyser reading, expressed as a mole fraction;

x_{CO_2} is the carbon dioxide analyser reading during test, expressed as a mole fraction;

$x_{\text{H}_2\text{O}}^{\text{a}}$ is the ambient mole fraction of water vapour during test;

H is the relative humidity in percent in the laboratory before the start of the test;

p is the ambient pressure in pascals (Pa) before the start of the test;

T_{s} is the temperature in the measurement section of the duct in Kelvin (K).

Before carrying out the calculations, the outputs from the oxygen and CO₂ analysers (and any other analysers on the sample line) should be corrected for the “delay time” calculated as described in 11.2. The outputs from the oxygen, CO₂ analyser (and any other analysers), the pressure measuring instrument, the duct temperature instrument and the light meter should then be corrected for the “duct flow time” calculated as described in 11.2.

In order to determine the duct constant C when an orifice plate is used to determine duct flow, a test is normally carried out using a propane burner at a constant known rate of fuel usage. The constant is then determined by solving Equations (E.2) and (E.4) after setting \dot{q} to zero. In these circumstances it is not possible to use this test for the purposes of HRR measurement confirmation.

E.2.3 Equations (E.3) to (E.7) are based on certain approximations leading to the following limitations.

- The amount of CO generated is not taken into consideration. Normally, the error is negligible. However, it has been pointed out that, when flame retardants are present or the conditions in the vicinity of the combustion are vitiated (Reference [7]), the concentrations can be significant. In such circumstances alternative, more complex calculation procedures are available (References [6] and [7]) which take this into account.
- The influence of water vapour on measurement is only partially taken into consideration. A correction for this error can be obtained only by continuous measurement of the partial water vapour pressure.
- The value of 17,2 kW m⁻³ for the factor E , is an average value for a large number of products and gives an acceptable accuracy in most cases.

These accumulated errors should normally be less than 10 %.

E.3 Combustion gases

The instantaneous rate of gas production \dot{V}_{gas} , expressed in cubic metres per second at 0,1 MPa and 25 °C and the total amount of gas production V_{gas} , expressed in cubic metres at 0,1 MPa and 25 °C, should be calculated from the following:

$$\dot{V}_{\text{gas}} = \dot{V}_{298}(x_i^{\text{a}} - x_i^0)(1 - x_{\text{H}_2\text{O}}^{\text{a}}) \quad (\text{E.8})$$

$$V_{\text{gas}} = \int_0^t \dot{V}_{\text{gas}} dt \quad (\text{E.9})$$

where

- \dot{V}_{298} is the rate of volume flow in exhaust duct, expressed in cubic metres per second at 0,1 MPa and 25 °C;
- x_i^a is the mole fraction of specified gas in the analyser;
- x_i^0 is the initial mole fraction of specified gas in the analyser;
- t is the time from ignition, expressed in seconds.

E.4 Light obscuration

The optical density is represented by the extinction coefficient, k , expressed in reciprocal metres (m^{-1}), and should be calculated from the following:

$$k = \frac{1}{L} \ln \left[\frac{I_0}{I} \right] \quad (E.10)$$

where

- I_0 is the light intensity for a beam of parallel light rays measured in a smoke free environment;
- I is the light intensity for a parallel light beam having traversed a certain length of smoky environment;
- L is the length of beam through smoky environment, expressed in metres.

The instantaneous rate of production of light-obscuring smoke R_{inst} , expressed in square metres per second ($m^2 s^{-1}$), and the total amount of smoke R_{tot} , expressed in square metres (m^2) should then be calculated from:

$$R_{inst} = k\dot{V}_s \quad (E.11)$$

$$R_{tot} = \int_0^t k\dot{V}_s dt \quad (E.12)$$

where

- \dot{V}_s is the volume flow in the exhaust duct at actual duct gas temperature, expressed in cubic metres per second;
- t is the time from ignition, expressed in seconds.

Annex F (informative)

Ignition sources

F.1 General

In general, the heat source will be a fraction (e.g. 10 %) of the maximum heat release rate expected in the test, as the purpose of the test is usually to determine how the product itself contributes to the increase of fire size. A range of different ignition sources is given in existing standards (including ISO 11925-3^[2], ISO 10093^[1], ISO 9705, ISO 13784-2, EN 1021-1^[3], EN 1021-2^[4], BS 5852^[9], BS 5852-2^[10] and EN 13823) comprising cigarettes, gas burners and wooden cribs. Liquid pool fires can also be used.

The gas metering system will normally be a gas rotameter system or mass flow controller with a manufacturer's calibration. A mass-flow controller is recommended as the output can be data logged and the time-related contribution of the source can then be accurately subtracted from the curve of rate of heat release. For large burners, the system may also include a gas evaporator if propane is used as fuel. When a mass flow controller unit is used the output shall be logged with the same frequency as the other instrumentation.

An alternative metering system (Reference [6]) that can be used to carry out a calibration burn consists of a flow control valve and a rotary gas meter with an electronic output connected to the data logging system, in line with the gas burner.

If a premixed flame is required, a burner fed with natural gas or methane and air may be used. A suitable system should be fitted with gas jets and a flashback arrestor unit.

The use of a gas-fired radiant panel ignition source presents some difficulties in combination with oxygen depletion calorimetry. The gas supply to the panel needs to be accurately measured and controlled and the exhaust gases need to be completely collected by the hood. The contribution of the panel can then be calculated and subtracted. An alternative is to use an electrical panel; however experience has shown that this may not be sufficiently robust for the conditions of use.

F.2 Ignition sources for specific products

A list of some ignition sources that have been used in specific research projects or standard tests is given in Table F.1. A specific igniting object may also be used.

Table F.1 — Typical ignition sources for use in tests using open calorimetry

Ignition source	Reference	RHR kW	THR MJ	Average heat flux kW/m ²	Application time s
Small flame — simulated electrical fault	ISO 11925-3 ^[2]	0,05	15×10^3 to 9×10^3	36	30 to 180
Cigarette lighter	ISO 11925-3 ^[2] (Source D)	0,28	$8,4 \times 10^{-3}$	30 - 36	30
Newspaper (100 g cushion)	UIC 564-2 ^[11]	7 to 30	1,4 to 1,7	25 to 40	180
Wood crib (126 g, pine)	BS 5852-2 crib 7 ^[10]	6 to 8,4	1,9 to 2.2	25 to 35	370 to 390
Gas burner — typical simulated burning vandalised train seat	EN/TR 45545-1 (Annex A, source 5) ^[12]	(a) 75 + (b) 150	(a) 9 + (b) 72	(a) 20 to 25 + (b) 40-50	(a) 120 + (b) 480
Gas burner — typical simulated burning chair or wastepaper basket	ISO 9705	(a) 100 + (b) 300	(a) 60 + (b) 180	(a) 30 to 40 + (b) 50-60	(a) 600 + (b) 600

F.3 Room installations or part installations

Sand box burners or line burners using gaseous fuel are suitable for testing these and other vertical installations. A number have been described in the following standards: ISO 9705, ISO 13784-2, ISO 13785-1 and EN 13823. The burner should usually be placed in contact with the product. A test for a room installation made out of sandwich panel components and placed under a calorimeter hood has been described in ISO 13784-1.

F.4 Furniture

Ignition sources that have been used in combination with furniture (see Table F.1) include: crumpled newspaper, newspaper in a cage, wooden crib, ring burner (Reference [13]), see Figure G.1, and a special gas burner (Reference [14]).

The size and positioning of an ignition source is best chosen such that a comparison of the outputs can be made with existing substantial databases, e.g. CBUF [15] In general, the ignition source should be placed either centrally above or below the seat or bed. In the case of a seat that has arm rests, it should be placed near a corner formed by the base, back and arm of a chair or sofa, which, because of feedback, represents a worst case.

A specific procedure for the testing of upholstered furniture, based on this and other research work and established regulatory test procedures, is given in Annex G.

F.5 Other consumer items

Any of the sources referred to in Clauses F.1, F.2, F.3 and F.4 may be used according to the product and the test scenario.

Annex G (normative)

Specific procedure for testing upholstered furniture

G.1 Prepare the test and set initial test conditions in accordance with Clause 13 and 14.1.

G.2 Weigh the test item to an accuracy of 100 g and then place it in a metal tray (2 000 mm × 1 000 mm with sides of 100 mm), centrally on a weigh platform, under the hood of a calorimeter. The top of the platform shall consist of a 12 mm thick calcium silicate board (of density $(850 \pm 50) \text{ kg m}^3$ and dimensions 2 400 mm × 1 200 mm).

G.3 Position a burner (References [13], [15]) as shown in Figure G.1 (and constructed according to the requirements of Reference [13]) with the ring in a horizontal plane 25 mm above the surface of the test item as follows:

- chair/settee with arm rests (seat > 500 mm wide — 50 mm from the back with left hand side of burner, 125 mm from left armrest);
- chair/settee with arm rests (seat < 500 mm wide) — centrally on the seat, 50 mm from the back;
- chair/settee with no arm rests — centrally on the seat, 50 mm from the back;
- bed — centrally positioned.

Dimensions in millimetres

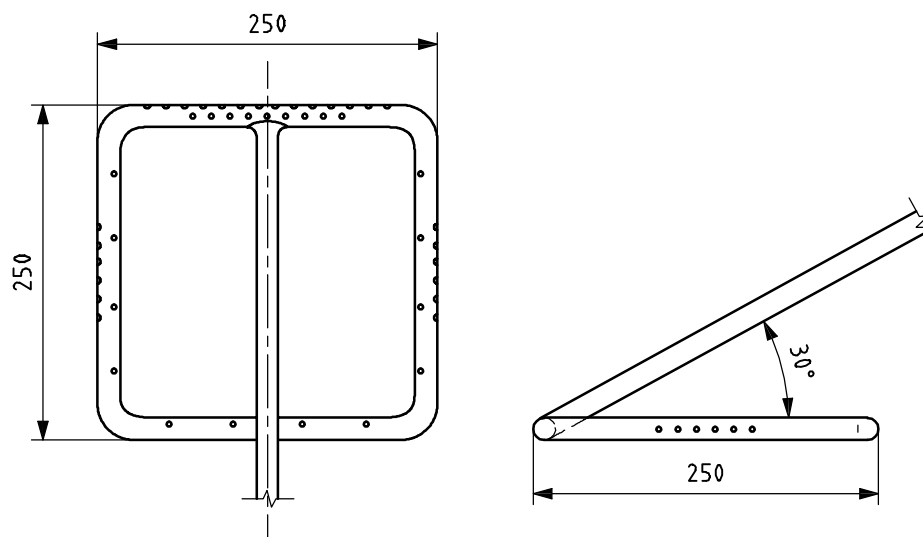

All tubing 12,7 mm; all holes 1 mm.

Figure G.1 — Ring burner (Reference [15])

G.4 Record and photograph full details of the test arrangement.

G.5 Set the volume flow of the calorimeter to $2,5 \text{ m}^3 \text{ s}^{-1}$.

G.6 Ignite the burner and adjust it to the required output levels within 10 s of ignition. Run the burner with natural grade propane (95 % purity) at a heat output of 30 kW for 120 s. The gas flow to the burner shall be measured with an accuracy of at least 3 %. The heat output to the burner shall be controlled to within 5 % of the prescribed value. Adjust the exhaust capacity so that all combustion products are collected.

NOTE In cases where large amounts of smoke are expected to be produced, it is acceptable to remove the baffle plates from the plenum of an ISO 9705 calorimeter hood to ensure that all the combustion products are collected.

After switching off the burner, remove it unless burning material is adhering to it, in which case leave it in position for the duration of the test.

G.7 Start all recording and measuring devices and allow them to run for at least 2 min prior to ignition of the burner.

G.8 Make a photographic and/or video recording of the test. A clock shall appear in all photographic records, giving time to the nearest 1 s.

G.9 During the test, record observations and the times that they occur.

G.10 The end of the test shall be 30 min from ignition of the burner. To allow for the effect of delay times, it may be necessary to continue the collection of instrumental data for an additional period.

G.11 Report the extent of damage of the product after the test.

G.12 Record any other unusual behaviour.

G.13 The test report shall contain the following information:

- a) name and address of the testing laboratory;
- b) date and identification number of the report;
- c) name and address of the sponsor;
- d) purpose of the test;
- e) method of sampling;
- f) name and address of manufacturer or supplier of the product;
- g) name or other identification marks and description of the product:
 - 1) drawings/photographs;
 - 2) description;
 - 3) specification of materials of construction;
 - 4) date of supply of the product;
 - 5) date of test;
- h) test method used;
- i) conditioning of the test specimen, environmental data during the test (temperature, atmospheric pressure, relative humidity, etc.);
- j) deviations from the test method, if any;
- k) test results:
 - 1) observations during and after the test;
 - 2) time/volume flow in the exhaust duct (optional);
 - 3) time/rate of total heat release;
 - 4) time/heat release excluding that from the burner;
 - 5) time/production of light-obscuring smoke at actual duct flow temperature;
 - 6) time/rate of mass loss;
 - 7) integrals of the data in 3), 4), 5) and 6) over a period of 30 min from the time of ignition of the burner.

Annex H (informative)

Repeatability and reproducibility

H.1 General

The variability of each output parameter in a set of test data can be described in terms of repeatability, r , and reproducibility, R , in accordance with ISO 5725-2.

Such data have been presented for a furniture calorimeter (using the hood/duct system of the ISO 9705 calorimeter) in the CBUF ^[15] project. Omitting the results for one product, which did not always give ignition, r and R of the maximum HRR were 18 % to 32 % and 23 % to 64 % respectively. (Values of r and R are defined as the ratio of a multiple of the standard deviation representing the 95 % confidence level to the mean value, expressed as a percentage.)

A further study (Reference [16]) of data from the cone calorimeter reported that r and R of the maximum HRR were 17 % and 23 % respectively.

It is found that the values obtained for repeatability and reproducibility can depend on the nature of products tested and become greater for lower values of oxygen depletion.

Statistical information on the performance of a particular measuring system, discounting the effects of specific products may be obtained from repeated testing using a gas burner.

H.2 Uncertainty

In this approach, the uncertainty is an expression of the statistical variation in any parameter, obtained from calculation procedures using statistical data and information on the precision of the measuring system and its components (References [6] and [17]).

A recent analysis of data from a 3 MW calorimeter (Reference [6]) derived an expanded relative uncertainty of 11 % for measurements of HRR of 0,4 MW to 3 MW. It should be noted that when studying large fires with high flow rates, the data produced in the transient, developing stages of the fire will be subject to a higher uncertainty, attributable in a large part to the higher uncertainty of the oxygen depletion measurement.

Bibliography

- [1] ISO 10093, *Plastics — Fire tests — Standard ignition sources*
- [2] ISO 11925-3, *Reaction to fire tests — Ignitability of building products subjected to direct impingement of flame — Part 3: Multi-source test*
- [3] EN 1021-1, *Furniture — Assessment of the ignitability of upholstered furniture — Part 1 Ignition source: smouldering cigarette*
- [4] EN 1021-2, *Furniture — Assessment of the ignitability of upholstered furniture — Part 2 Ignition source: match flame equivalent*
- [5] *The NIST Large Fire Liquid Spray Burner*, NIST Internal Report
- [6] BRYANT, R.A., OHLEMILLER, T.J., JOHNSON, E.J., HAMINS, A., GROVE, B.S., GUTHRIE, W.F., MARANGHIDES, A. and MULHOLLAND, G. W. *The NIST 3 Megawatt Quantitative Heat Release Rate Facility*, NIST Special Publication 1007, 2003
- [7] *Heat release in fires*, Eds. Babrauskas, V. and Grayson, S.J., Elsevier, Amsterdam, 1992
- [8] American National Standard for Cleanroom Materials Flammability Test Protocol, ANSI/FM Approvals 4910, June 2004, FM Approvals, 1151 Boston-Providence Turnpike, Norwood, MA 02062 USA
- [9] BS 5852:1990, *Methods of test for the assessment of the ignitability of upholstered seating by smouldering and flaming ignition sources*
- [10] BS 5852-2:1982, *Methods of test for the ignitability of upholstered composites for seating by flaming sources*
- [11] International Union of Railways (UIC), *Regulations relating to fire protection and fire fighting measures in passenger carrying railway vehicles used in international services*, UIC 564-2, 3rd Edn., 1 January 1991 (and 2 amendments)
- [12] CEN/TS 45545-1:2006, *Railway applications — Fire protection on railway vehicles — Part 1: General*.
- [13] *Furniture test*, California Technical Bulletin 133, State of California Department of Consumer Affairs
- [14] CEN/TS 45545-2:2006, *Railway applications — Fire protection on railway vehicles — Part 2: Requirements for the fire behaviour of materials and components*
- [15] CBUF, *Fire safety of upholstered furniture — The final report of the CBUF research programme*, Edit. Sundstrom, B. Interscience Communications Limited
- [16] JANSSENS, M. *Heat Release Rate (HRR)*. Edit. OHLEMILLER, T.J., JOHNSON, E.L. and GANN, R.G. *Measurement Needs for Fire Safety: Proc. of an Intl. Workshop (NISTIR 6527)*, Nat. Inst. Stand. and Technol., Gaithersburg MD, 2000
- [17] AXELSON, J., ANDERSSON, P., LONNERMARK, A., VAN HEES, P. and WETTERLUND, I. *Uncertainties in Measuring Heat and Smoke Release rates in the Room/Corner Test* and the SBI, Nordtest Technical Report 477, Nordtest Project No. 1480-00

