

First edition
2006-02-01

**Resilient and textile floor coverings —
Determination of length, width and
straightness of sheet**

*Revêtements de sol résilients et textiles — Détermination de la longueur,
de la largeur et de la rectitude des lés*



Reference number
ISO 24341:2006(E)

© ISO 2006

PDF disclaimer

This PDF file may contain embedded typefaces. In accordance with Adobe's licensing policy, this file may be printed or viewed but shall not be edited unless the typefaces which are embedded are licensed to and installed on the computer performing the editing. In downloading this file, parties accept therein the responsibility of not infringing Adobe's licensing policy. The ISO Central Secretariat accepts no liability in this area.

Adobe is a trademark of Adobe Systems Incorporated.

Details of the software products used to create this PDF file can be found in the General Info relative to the file; the PDF-creation parameters were optimized for printing. Every care has been taken to ensure that the file is suitable for use by ISO member bodies. In the unlikely event that a problem relating to it is found, please inform the Central Secretariat at the address given below.

© ISO 2006

All rights reserved. Unless otherwise specified, no part of this publication may be reproduced or utilized in any form or by any means, electronic or mechanical, including photocopying and microfilm, without permission in writing from either ISO at the address below or ISO's member body in the country of the requester.

ISO copyright office
Case postale 56 • CH-1211 Geneva 20
Tel. + 41 22 749 01 11
Fax + 41 22 749 09 47
E-mail copyright@iso.org
Web www.iso.org

Published in Switzerland

Foreword

ISO (the International Organization for Standardization) is a worldwide federation of national standards bodies (ISO member bodies). The work of preparing International Standards is normally carried out through ISO technical committees. Each member body interested in a subject for which a technical committee has been established has the right to be represented on that committee. International organizations, governmental and non-governmental, in liaison with ISO, also take part in the work. ISO collaborates closely with the International Electrotechnical Commission (IEC) on all matters of electrotechnical standardization.

International Standards are drafted in accordance with the rules given in the ISO/IEC Directives, Part 2.

The main task of technical committees is to prepare International Standards. Draft International Standards adopted by the technical committees are circulated to the member bodies for voting. Publication as an International Standard requires approval by at least 75 % of the member bodies casting a vote.

Attention is drawn to the possibility that some of the elements of this document may be the subject of patent rights. ISO shall not be held responsible for identifying any or all such patent rights.

ISO 24341 was prepared by Technical Committee ISO/TC 219, *Floor coverings*.

.....

.....

Resilient and textile floor coverings — Determination of length, width and straightness of sheet

1 Scope

This International Standard specifies methods for determining the length, width and straightness of resilient or textile floor coverings in sheet form.

The straightness of resilient or textile floor is an important consideration because the installed flooring will have an objectionable appearance if the machine direction edges of the sheet flooring deviate excessively from a straight line.

2 Principle

A test piece, resting on a flat surface, is measured at several points along its width and length.

The straightness at the deviation point of a test piece of a resilient or textile sheet resting on a flat surface is carried out by measuring the deviation from a virtual straight line passing through both ends of an edge.

3 Apparatus

3.1 Ruler or semi-rigid tape, accurate 0,05 %.

3.2 Table or flat surface, of greater width and, if possible, of greater length than the test piece to be measured.

3.3 Measuring device, for measuring the length of the sheet to an accuracy of 0,1 %, e.g. a calibrated measuring wheel, steel tape.

3.4 String line, length 10 m.

4 Atmosphere for conditioning and testing

Condition the test specimen for at least 4 h at ambient room temperature and test in the same environment.

5 Sampling and selection of specimens

Use the entire roll of floor covering if both length and width are to be determined. If only width is to be determined, the test piece shall have an approximate length of 200 mm.

In order to determine the straightness of a sheet material, a test piece with a minimum length of 5 m shall be taken.

6 Test procedure

6.1 Measurement of width

Place the test piece on the table, with the wear layer upward. Measure the width, using a ruler or semi-rigid tape (3.1), at three positions, equally divided over the length of the test piece, as shown in Figure 1.

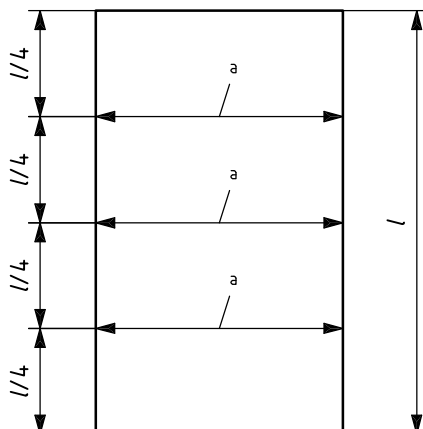

- a Test piece width.
- l Test piece length.

Figure 1 — Measurement of width

6.2 Measurement of length

6.2.1 Lay out the sheet completely flat with the wear layer upward. Measure with measuring device (3.3) the length in two places parallel to the axis of the test piece approximately 200 mm from the edges, as shown in Figure 2.

6.2.2 If the table is shorter than the length of the roll, take the measurement part by part. Unroll as far as possible and follow the procedure as often as necessary to measure the full length.

Alternatively, if the roll is significantly longer than the table, measure the length of the roll by re-rolling using a device with a calibrated measuring wheel.

Dimensions in millimetres

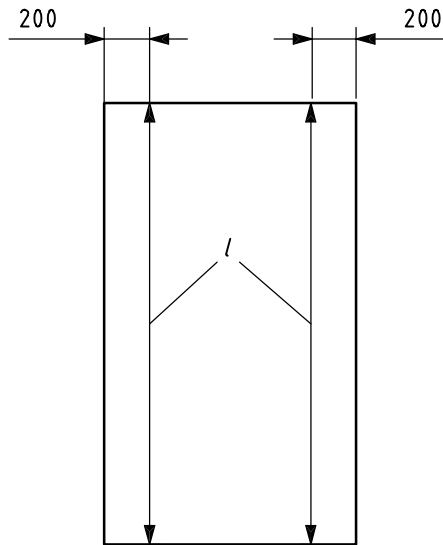

l Test piece length.

Figure 2 — Measurement of length

6.3 Measurement of straightness

Lay out the test piece completely flat with the wear layer upward. For a measured length of 5 m to 10 m, measure the straightness of an edge against the string line. Record the greatest deviation and the reference length, as shown in Figure 3.

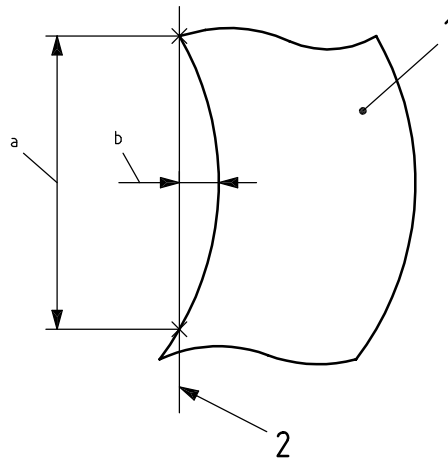

Key

- 1 sheet
- 2 string line
- a Reference length.
- b Deviation.

Figure 3 — Measurement using a string line

7 Calculation and expression of results

Calculate the effective width of the test piece as the smallest of the three measurements. Round off to the nearest 5 mm and express the result in millimetres.

Calculate the mean value of the two recorded lengths. Round off to the nearest 0,05 m and express the result in metres.

Express the results of the greatest deviation from straightness to the nearest 5 mm.

8 Precision statement

An interlaboratory test will be conducted to determine the precision of this method.

9 Test report

The test report shall contain the following information:

- a) a statement that the tests were performed in accordance with this International Standard, i.e. ISO 24341:2006;
- b) complete identification of the product tested, including type, source, colour and manufacturer's reference numbers;
- c) previous history of the sample;
- d) mean value of width in millimetres;
- e) mean value of length in millimetres;
- f) value of straightness in millimetres and the reference length in meters
- g) temperature at which the test was conducted;
- h) precision statement (see Clause 8);
- i) any deviation from this International Standard which may have affected the results.

Bibliography

- [1] EN 426:1993, *Resilient Floor Coverings — Determination of width, length, straightness and flatness of sheet material*
- [2] JIS A 1454, *Test Methods — Resilient floor coverings, section 6.4 — Dimension of Floor Sheet*

ICS 97.150

Price based on 5 pages