

---

---

**Laminate and textile floor coverings —  
Determination of dimensional variations  
after exposure to humid and dry climate  
conditions**

*Revêtements de sols stratifiés et textiles — Détermination des  
variations dimensionnelles après exposition à des conditions  
climatiques humides et sèches*



**PDF disclaimer**

This PDF file may contain embedded typefaces. In accordance with Adobe's licensing policy, this file may be printed or viewed but shall not be edited unless the typefaces which are embedded are licensed to and installed on the computer performing the editing. In downloading this file, parties accept therein the responsibility of not infringing Adobe's licensing policy. The ISO Central Secretariat accepts no liability in this area.

Adobe is a trademark of Adobe Systems Incorporated.

Details of the software products used to create this PDF file can be found in the General Info relative to the file; the PDF-creation parameters were optimized for printing. Every care has been taken to ensure that the file is suitable for use by ISO member bodies. In the unlikely event that a problem relating to it is found, please inform the Central Secretariat at the address given below.

© ISO 2006

All rights reserved. Unless otherwise specified, no part of this publication may be reproduced or utilized in any form or by any means, electronic or mechanical, including photocopying and microfilm, without permission in writing from either ISO at the address below or ISO's member body in the country of the requester.

ISO copyright office  
Case postale 56 • CH-1211 Geneva 20  
Tel. + 41 22 749 01 11  
Fax + 41 22 749 09 47  
E-mail [copyright@iso.org](mailto:copyright@iso.org)  
Web [www.iso.org](http://www.iso.org)

Published in Switzerland

# Contents

Page

Foreword.....	iv
<b>1 Scope .....</b>	<b>1</b>
<b>2 Principle .....</b>	<b>1</b>
<b>3 Apparatus .....</b>	<b>1</b>
<b>4 Test specimens .....</b>	<b>3</b>
<b>5 Procedure .....</b>	<b>5</b>
<b>5.1 Installation of the test floor.....</b>	<b>5</b>
<b>5.2 Climatic test periods.....</b>	<b>5</b>
<b>5.3 Measurements .....</b>	<b>5</b>
<b>6 Calculations and expression of results.....</b>	<b>9</b>
<b>6.1 General.....</b>	<b>9</b>
<b>6.2 Dimensional variations.....</b>	<b>9</b>
<b>6.3 Width flatness (only for laminate floor coverings) (<math>C</math>).....</b>	<b>9</b>
<b>6.4 Openings between the elements (only for laminate floor coverings) (<math>J_L</math> and <math>J_S</math>).....</b>	<b>10</b>
<b>6.5 Height difference between elements (only for laminate floor coverings) (<math>h_L</math> and <math>h_S</math>).....</b>	<b>10</b>
<b>6.6 Flatness (only for laminate floor coverings) (<math>f_l</math> and <math>f_w</math>).....</b>	<b>10</b>
<b>7 Test report .....</b>	<b>11</b>

## Foreword

ISO (the International Organization for Standardization) is a worldwide federation of national standards bodies (ISO member bodies). The work of preparing International Standards is normally carried out through ISO technical committees. Each member body interested in a subject for which a technical committee has been established has the right to be represented on that committee. International organizations, governmental and non-governmental, in liaison with ISO, also take part in the work. ISO collaborates closely with the International Electrotechnical Commission (IEC) on all matters of electrotechnical standardization.

International Standards are drafted in accordance with the rules given in the ISO/IEC Directives, Part 2.

The main task of technical committees is to prepare International Standards. Draft International Standards adopted by the technical committees are circulated to the member bodies for voting. Publication as an International Standard requires approval by at least 75 % of the member bodies casting a vote.

Attention is drawn to the possibility that some of the elements of this document may be the subject of patent rights. ISO shall not be held responsible for identifying any or all such patent rights.

ISO 24339 was prepared by Technical Committee ISO/TC 219, *Floor coverings*.

.....

# Laminate and textile floor coverings — Determination of dimensional variations after exposure to humid and dry climate conditions

## 1 Scope

This International Standard specifies a process to determine the capability of laminate and textile floor coverings to withstand exposure to moderate humid and dry climate conditions. The subclauses pertaining to flatness, openings between elements and height differences between elements only apply to laminated floor coverings.

## 2 Principle

To simulate as real use conditions as possible, a test floor covering with an approximate area of 5,5 m<sup>2</sup> is installed in a climate chamber. After a conditioning period of one week, the floor covering is exposed for four weeks to humid climate and finally another four weeks to dry climate conditions. When applicable, after each week, dimensional variations, flatness, openings between elements, height differences between elements, etc. are recorded.

## 3 Apparatus

**3.1 Climate chamber**, of large enough size to have room for a subfloor as described in 3.2, enabling the following atmospheres to be maintained:

- an atmosphere of  $(23 \pm 2) ^\circ\text{C}$  and  $(50 \pm 5) \%$  relative humidity (RH) called conditioning atmosphere;
- an atmosphere of  $(23 \pm 2) ^\circ\text{C}$  and  $(85 \pm 5) \%$  relative humidity (RH) called humid atmosphere;
- an atmosphere of  $(23 \pm 2) ^\circ\text{C}$  and  $(30 \pm 5) \%$  relative humidity (RH) called dry atmosphere.

It is possible to use one chamber to maintain successively the three atmospheres or to have three chambers, each one maintaining only one of these atmospheres all the time.

**3.2 Subfloor**, with an approximate size of 3 m × 2 m, rigid and flat (maximum tolerances  $\pm 5$  mm / 2 m and  $\pm 1$  mm / 200 mm).

**3.3 Set of thickness gauges**, with accuracy and an interval of 0,05 mm.

**3.4 Apparatus for measuring width flatness**, consisting of a dial gauge accurate to  $\pm 0,01$  mm with a rounded tip of radius  $\leq 5$  mm, installed centrally in relation to three rounded supports with radius  $\geq 5$  mm. The supports shall be adjustable along a T-shaped assembly of bars to provide the required gauge length. The measurement,  $d$ , shall not be less than the width,  $w$ , of the test specimen minus 10 mm. The tip of the gauge in contact with the face of the test specimen shall apply a force of  $(1,0 \pm 0,5)$  N. The mass of the apparatus shall not affect the flatness of the test specimen beyond the limit of the accuracy of the gauge. See Figure 1. The instrument shall be set to zero against a suitable reference plate.

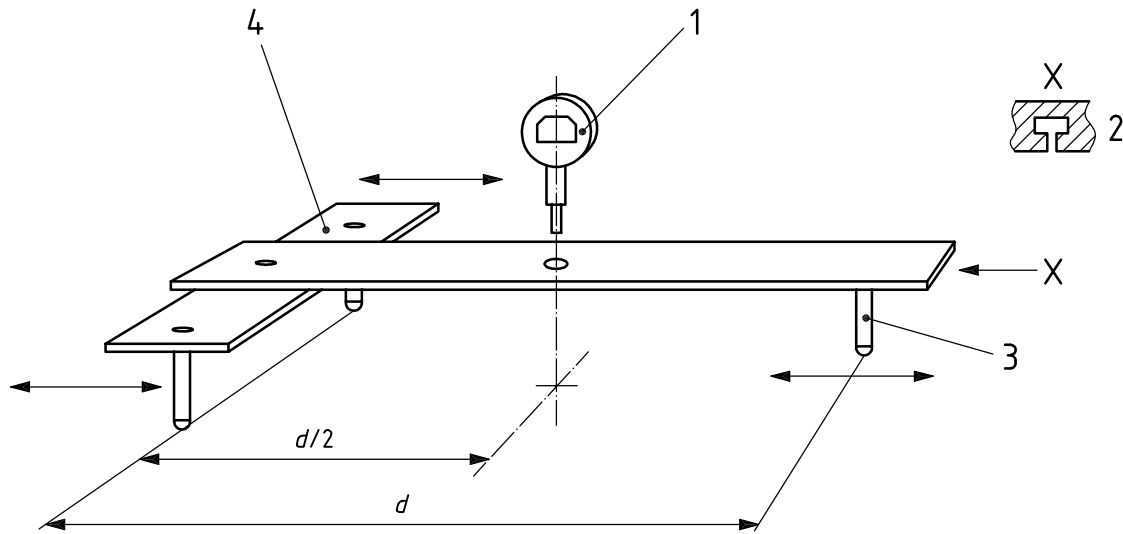

**Key**

- 1 dial gauge
- 2 T-groove
- 3 adjustable pin
- 4 adjustable bridge

**Figure 1 — Apparatus for measuring width flatness, principle**

**3.5 Calliper gauge or any other equivalent tool** with an accuracy of  $\pm 0,01$  mm.

**3.6 Flexible steel ruler**, of length about 2 600 mm.

**3.7 Flexible steel ruler**, of length about 1 600 mm.

**3.8 Rigid ruler**, 1 500 mm long, with a bow less than 0,1 mm.

**3.9 Measurement bridge**, (movable in Y-axis), with a bow less than 0,1 mm equipped with a calliper gauge (movable in X-axis), with an accuracy of  $\pm 0,01$  mm.

The idea with this measurement bridge is to cover the entire test area with one instrument. See Figure 2.

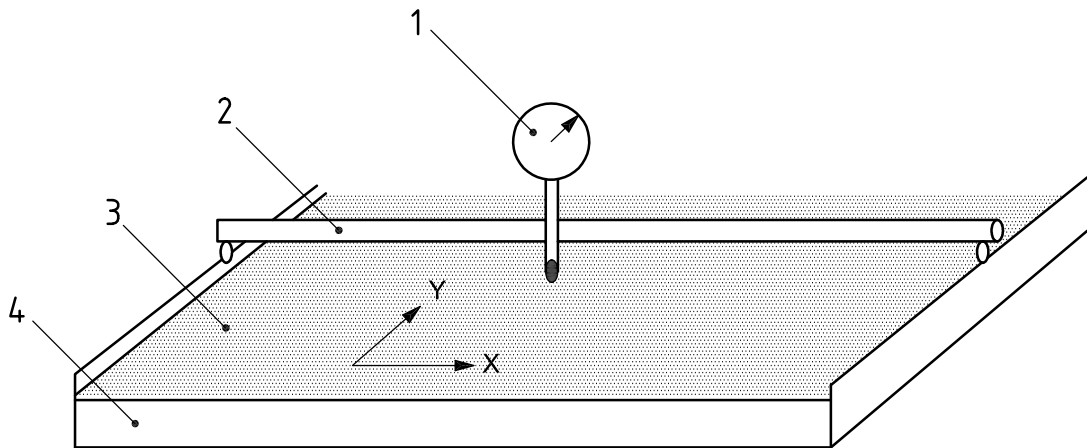

### Key

- 1 calliper gauge according to 3.5 (movable in X-axis)
- 2 measurement bridge (movable in Y-axis)
- 3 installed test floor covering
- 4 ridged frame (of, e.g. steel or aluminium)

**Figure 2 — Principle of a measurement bridge**

## 4 Test specimens

Take enough floor covering of the materials to be tested to be able to cover a test area of 1 900 mm × 2 900 mm according to the drawing in Figure 3. If applicable, the materials shall be sampled so that the long sides of the elements are aligned as shown in Figure 3. If the elements are equipped with a factory applied underlay, all tests shall be carried out with this material kept on, i.e. no pre-attached underlay material shall be taken off prior to testing. Sample the necessary quantity of textile floor covering to cover a test area of 1 900 mm × 2 900 mm. The material shall be tested in accordance with the manufacturer instruction for installation in order to simulate as real *in situ* situations as possible. No conditioning is necessary prior to installation in the test chamber.

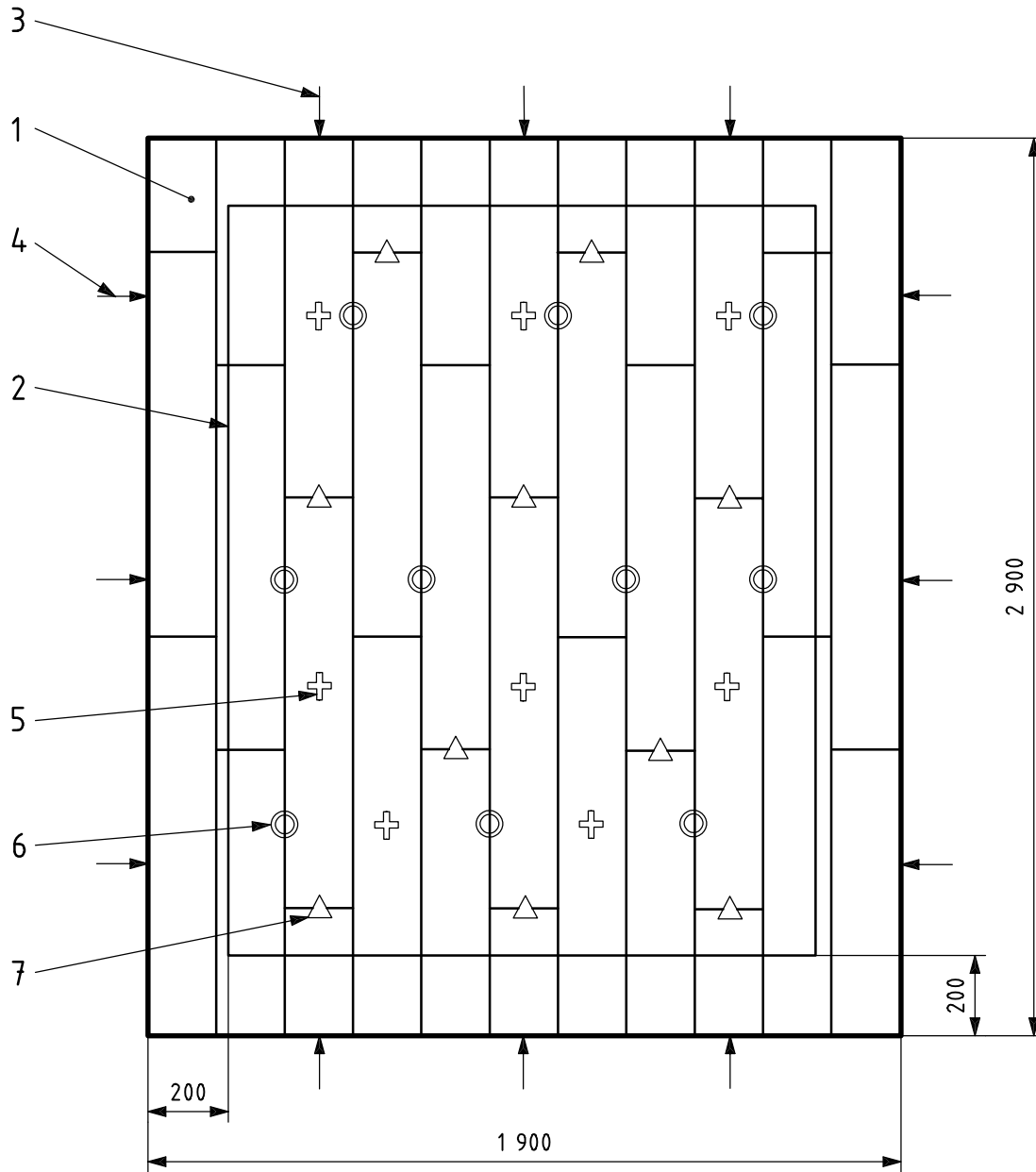

**Key**

- 1 installed floor covering to be tested
- 2 measurement area
- 3 measuring-points, dimensional variations of the length (3)
- 4 measuring-points, dimensional variations of the width (3)
- 5 measuring-points of the width flatness (10)
- 6 measuring-points of the openings in the joints and the height difference between the elements at the long side of the elements (10)
- 7 measuring-points of the openings in the joints and the height difference between the elements at the short side of the elements (10)

**Figure 3 — Measurement scheme, general principle**



## 5 Procedure

### 5.1 Installation of the test floor

Following the principle drawing from Figure 3, install the floor covering elements to be tested on the subfloor in the climate chamber. The installation shall be in accordance with the instructions from the manufacturer and in a conditioned atmosphere of  $(23 \pm 2) ^\circ\text{C}$  and  $(50 \pm 5) \%$  relative humidity. The installed floor shall have a minimum size of  $1\,900\text{ mm} \times 2\,900\text{ mm}$ . If applicable, the long sides of the floor covering elements shall be aligned with the long side of the test area. In the case of textile floor coverings, install the floor covering so that the longest side of the tested area corresponds to the direction of manufacture.

### 5.2 Climatic test periods

#### 5.2.1 Conditioning atmosphere

After the installation of the floor covering in the climate chamber, the atmosphere is kept constant for 7 days at  $(23 \pm 2) ^\circ\text{C}$  and with a  $(50 \pm 5) \%$  relative humidity (RH), conditioning atmosphere.

#### 5.2.2 Humid atmosphere

Once the period in the conditioning atmosphere has passed, the atmosphere in the climate chamber shall be changed to a humid atmosphere at  $(23 \pm 2) ^\circ\text{C}$  and with a  $(85 \pm 5) \%$  relative humidity (RH). This humid atmosphere is then kept constant for a period of four weeks.

#### 5.2.3 Dry atmosphere

Once the period in the humid atmosphere has passed, the atmosphere in the climate chamber shall be changed to a dry atmosphere at  $(23 \pm 2) ^\circ\text{C}$  and with a  $(30 \pm 5) \%$  relative humidity (RH). This dry atmosphere is then kept constant for a new period of four weeks.

### 5.3 Measurements

#### 5.3.1 General

Perform the initial measurement after the 7 days conditioning period. Then repeat the measurements every 7 days until the end of the dry period. Except for measuring dimensional variations, all the measuring points shall be situated at a distance of at least 200 mm from the edges (see Figure 3). All measurements shall always be made at the same points. Each measuring point shall be clearly marked and numbered before the initial measurement. For examples of numbering, see Table 1 and Table 2.

#### 5.3.2 Measuring dimensional variations

##### 5.3.2.1 Dimensional variations — General

Only the dimensional variations are looked for. An easy measurement of the variations can be taken with a steel ruler, the length of which is slightly shorter (10 mm for example) than the total distance to measure. This difference of length is measured with a calliper gauge at the different steps of the test.

It is also possible to measure, with a calliper gauge, the distance of the test area to a fixed frame outside of the test area.

##### 5.3.2.2 Dimensional variations across the width ( $\Delta w$ )

The measurements are taken at three points (see Figure 3). Each measurement needs to be taken between two thrusts fixed to the floor coverings, the distance of which is between 1 500 mm and 1 700 mm. For the

measurement against a fixed frame, no thrusts on the test area are necessary. Measure across the width of the elements for laminate floor coverings or over the smallest length of the tested surface for textile floor coverings.

#### 5.3.2.3 Dimensional variations along the length ( $\Delta l$ )

Same procedure as in 5.3.2.2, but the distance between the three thrusts is between 2 500 mm and 2 700 mm. Measure along the width of the elements for laminate floor coverings or over the longest length of the tested surface for textile floor coverings.

#### 5.3.3 Measuring the width flatness (only for laminate floor coverings) ( $C$ )

Choose each of the 10 points to measure the width flatness. These points shall be at least 50 mm from the end joint of the element. Measure the width flatness with the apparatus described in 3.4. Record all measured values, with its sign, to the nearest 0,01 mm.

#### 5.3.4 Measuring the openings between the elements (only for laminate floor coverings) ( $J_L$ and $J_S$ )

Choose each of the 10 points to measure the openings between the elements in the long side ( $J_L$ ) and short side ( $J_S$ ). Each of 10 measurements is taken where the opening between the elements initially seems the biggest.

To take the measurements, use the set of thickness gauges described in 3.3. The width of the opening is equal to the thickest thickness gauge that can be inserted applied with a minimum of force. Record all measured values with the result achieved from the appropriate thickness gauge.

#### 5.3.5 Measuring the height difference between elements (only for laminate floor coverings) ( $h_L$ and $h_S$ )

Choose each of the 10 points to measure the height difference between elements at the long ( $h_L$ ) and short sides ( $h_S$ ). Measure the  $h_L$  and  $h_S$  with the apparatus defined in 3.4. Move the apparatus across the joint between the two elements to have the height difference between the two elements. Record all measured values with the result achieved from the appropriate calliper gauge.

#### 5.3.6 Measuring the flatness of the test area (only for laminate floor coverings) ( $f_l$ and $f_w$ )

The flatness of the assembled floor covering can be measured by using the straight rigid ruler as described in 3.8. This ruler is moved along the floor in every direction [length ( $f_l$ ); width ( $f_w$ )] with the aim of detecting the biggest flatness deviation which is then measured with the help of the set of thickness gauges described in 3.3 or any other apparatus giving the same result. A measurement bridge described in 3.9 that can be moved on a frame outside of the test area can also be used.

Table 1 — Guidance for the recording and documentation of the measured parameters

All values in millimetres except where indicated	Initial	Humid cycle					Dry cycle			
	50 % RH	85 % RH					30 % RH			
	Day 7	Day 14	Day 21	Day 28	Day 35	Day 42	Day 49	Day 56	Day 63	
$\Delta w_1$										
$\Delta w_2$										
$\Delta w_3$										
$\Delta w_{avg}$										
$\Delta w_{avg} (\%)$										
$\Delta l_1$										
$\Delta l_2$										
$\Delta l_3$										
$\Delta l_{avg}$										
$\Delta l_{avg} (\%)$										
$C_1$										
$C_2$										
$C_3$										
$C_4$										
$C_5$										
$C_6$										
$C_7$										
$C_8$										
$C_9$										
$C_{10}$										
$C_{max}$										
$C_{avg}$										
$C_{avg} (\%)$										
$J_{L,1}$										
$J_{L,2}$										
$J_{L,3}$										
$J_{L,4}$										
$J_{L,5}$										
$J_{L,6}$										
$J_{L,7}$										
$J_{L,8}$										
$J_{L,9}$										
$J_{L,10}$										
$J_{L,max}$										
$J_{L,avg}$										
$J_{L,avg} (\%)$										

Table 2 — Guidance for the recording and documentation of the measured parameters

All values in millimetres except where indicated	Initial	Humid cycle					Dry cycle			
	50 % RH	85 % RH					30 % RH			
	Day 7	Day 14	Day 21	Day 28	Day 35	Day 42	Day 49	Day 56	Day 63	
$J_{S,1}$										
$J_{S,2}$										
$J_{S,3}$										
$J_{S,4}$										
$J_{S,5}$										
$J_{S,6}$										
$J_{S,7}$										
$J_{S,8}$										
$J_{S,9}$										
$J_{S,10}$										
$J_{S,max}$										
$J_{S,avg}$										
$J_{S,avg} (%)$										
$h_{L,1}$										
$h_{L,2}$										
$h_{L,3}$										
$h_{L,4}$										
$h_{L,5}$										
$h_{L,6}$										
$h_{L,7}$										
$h_{L,8}$										
$h_{L,9}$										
$h_{L,10}$										
$h_{L,max}$										
$h_{L,avg}$										
$h_{S,1}$										
$h_{S,2}$										
$h_{S,3}$										
$h_{S,4}$										
$h_{S,5}$										
$h_{S,6}$										
$h_{S,7}$										
$h_{S,8}$										
$h_{S,9}$										
$h_{S,10}$										
$h_{S,max}$										
$h_{S,avg}$										
$f_l$										
$f_w$										

## 6 Calculations and expression of results

### 6.1 General

The protocol in Table 1 and Table 2 can be used as guidance for the recording and documentation of the measured parameters.

### 6.2 Dimensional variations

#### 6.2.1 Across the width of the elements for laminate floor coverings or over the smallest length of the tested surface for textile floor coverings ( $\Delta w$ )

On the three points where the measurements were performed, calculate for each value the percentage of the dimensional variations between:

- a) the conditioning atmosphere and the corresponding values from the humid atmosphere;
- b) the conditioning atmosphere and the corresponding values from the dry atmosphere.

Express the results in percentage to the nearest 0,01 %.

#### 6.2.2 Along the width of the elements for laminate floor coverings or over the longest length of the tested surface for textile floor coverings ( $\Delta l$ )

On the three points where the measurements were performed, calculate for each value the percentage of the dimensional variations between:

- a) the conditioning atmosphere and the corresponding values from the humid atmosphere;
- b) the conditioning atmosphere and the corresponding values from the dry atmosphere.

Express the results in percentage to the nearest 0,01 %.

### 6.3 Width flatness (only for laminate floor coverings) ( $C$ )

From each of the 10 measuring points, indicate the maximum deviation values of width flatness measured ( $C_{max}$ ):

- a) at the end of the conditioning atmosphere;
- b) in the humid atmosphere;
- c) in the dry atmosphere;

and calculate the average value of the 10 measurements measured at each point:

- d) at the end of the conditioning atmosphere;
- e) in the humid atmosphere;
- f) in the dry atmosphere.

Express the results in millimetres, (if appropriate with its sign), to the nearest 0,01 mm.

#### 6.4 Openings between the elements (only for laminate floor coverings) ( $J_L$ and $J_S$ )

From each of the 10 measuring points, respectively, indicate maximum opening measured ( $J_{L,max}$  and  $J_{S,max}$ ):

- a) at the end of the conditioning atmosphere;
- b) in the humid atmosphere;
- c) in the dry atmosphere;

and calculate the average value of the 10 measurements measured at each point:

- d) at the end of the conditioning atmosphere;
- e) in the humid atmosphere;
- f) in the dry atmosphere.

Express the results in millimetres to the nearest 0,05 mm.

#### 6.5 Height difference between elements (only for laminate floor coverings) ( $h_L$ and $h_S$ )

From each of the 10 measuring points, respectively, indicate the maximum height difference between elements measured ( $h_{L,max}$  and  $h_{S,max}$ ):

- a) at the end of the conditioning atmosphere;
- b) in the humid atmosphere;
- c) in the dry atmosphere;

and calculate the average value of the 10 measurements measured at each point:

- d) at the end of the conditioning atmosphere;
- e) in the humid atmosphere;
- f) in the dry atmosphere.

Express the results in millimetres to the nearest 0,01 mm.

#### 6.6 Flatness (only for laminate floor coverings) ( $f_l$ and $f_w$ )

From each of the 10 measuring points, respectively, indicate maximum flatness deviation measured in both directions and calculate the percentage different from the respective initial measurement:

- a) in the humid atmosphere;
- b) in the dry atmosphere;

Express the result in percentage, if appropriate with its sign, to the nearest 0,05 mm.

## 7 Test report

The test report shall include the following information:

- a) reference to this International Standard (ISO 24339:2006) and, if any, the deviations;
- b) name and address of the laboratory that performed the test;
- c) name and address of the company requesting the test;
- d) name (brand if any) and the type of the floor covering tested;
- e) date of delivery of the test specimens;
- f) date period of the test;
- g) test results according to 6.2 and 6.3, preferably presented as in Table 1 and Table 2.

---

---

**ICS 97.150**

Price based on 11 pages