**Laminate floor coverings —
Determination of geometrical
characteristics**

*Revêtements de sol stratifiés — Détermination des caractéristiques
géométriques*



Reference number
ISO 24337:2006(E)

© ISO 2006

PDF disclaimer

This PDF file may contain embedded typefaces. In accordance with Adobe's licensing policy, this file may be printed or viewed but shall not be edited unless the typefaces which are embedded are licensed to and installed on the computer performing the editing. In downloading this file, parties accept therein the responsibility of not infringing Adobe's licensing policy. The ISO Central Secretariat accepts no liability in this area.

Adobe is a trademark of Adobe Systems Incorporated.

Details of the software products used to create this PDF file can be found in the General Info relative to the file; the PDF-creation parameters were optimized for printing. Every care has been taken to ensure that the file is suitable for use by ISO member bodies. In the unlikely event that a problem relating to it is found, please inform the Central Secretariat at the address given below.

© ISO 2006

All rights reserved. Unless otherwise specified, no part of this publication may be reproduced or utilized in any form or by any means, electronic or mechanical, including photocopying and microfilm, without permission in writing from either ISO at the address below or ISO's member body in the country of the requester.

ISO copyright office
Case postale 56 • CH-1211 Geneva 20
Tel. + 41 22 749 01 11
Fax + 41 22 749 09 47
E-mail copyright@iso.org
Web www.iso.org

Published in Switzerland

Contents

Page

Foreword.....	iv
1 Scope	1
2 Symbols	1
3 Test apparatus	1
4 Test specimens	2
4.1 General.....	2
4.2 Sampling.....	2
5 Conditioning.....	3
6 Test procedure	3
6.1 Determination of thickness (t)	3
6.2 Determination of length (l)	3
6.3 Determination of width (w)	4
6.4 Determination of squareness (q)	4
6.5 Determination of straightness (s)	5
6.6 Determination of width flatness (f_W)	6
6.7 Determination of length flatness (f_l).....	6
6.8 Determination of openings between elements (o).....	7
6.9 Determination of height difference between elements (h).....	8
7 Calculations and expression of results	8
7.1 Thickness (t)	8
7.2 Length (l).....	8
7.3 Width (w)	8
7.4 Squareness (q)	9
7.5 Straightness (s)	9
7.6 Width flatness (f_W)	9
7.7 Length flatness (f_l)	9
7.8 Openings between elements (o)	9
7.9 Height difference between elements (h)	9
8 Test report	9
Annex A (informative) Example of test results form.....	10

Foreword

ISO (the International Organization for Standardization) is a worldwide federation of national standards bodies (ISO member bodies). The work of preparing International Standards is normally carried out through ISO technical committees. Each member body interested in a subject for which a technical committee has been established has the right to be represented on that committee. International organizations, governmental and non-governmental, in liaison with ISO, also take part in the work. ISO collaborates closely with the International Electrotechnical Commission (IEC) on all matters of electrotechnical standardization.

International Standards are drafted in accordance with the rules given in the ISO/IEC Directives, Part 2.

The main task of technical committees is to prepare International Standards. Draft International Standards adopted by the technical committees are circulated to the member bodies for voting. Publication as an International Standard requires approval by at least 75 % of the member bodies casting a vote.

Attention is drawn to the possibility that some of the elements of this document may be the subject of patent rights. ISO shall not be held responsible for identifying any or all such patent rights.

ISO 24337 was prepared by Technical Committee ISO/TC 219, *Floor coverings*.

Laminate floor coverings — Determination of geometrical characteristics

1 Scope

This International Standard gives test methods to determine the dimensional variance between elements of laminate floor coverings in a manufactured free-standing shape (unrestricted) in respect to thickness, length, width, squareness, straightness, width flatness, length flatness, openings between assembled elements and height differences between assembled elements.

The precision of the specified test methods is not known. When the interlaboratory data becomes available, a precision statement will be added in subsequent revisions.

2 Symbols

d	distance between supports on apparatus for measuring width flatness
f_l	length flatness of a laminate floor covering element
f_w	width flatness of a laminate floor covering element
h	height difference between assembled laminate floor covering element
l	length of a laminate floor covering element, visible length of the surface layer
o	opening between assembled laminate floor covering element
q	squareness of a laminate floor covering element
s	straightness of a laminate floor covering element
t	total thickness of a laminate floor covering element
w	width of a laminate floor covering element, visible width of the surface layer

3 Test apparatus

3.1 Micrometer, calliper gauge or any other equivalent tool, having flat and parallel circular measuring surfaces of at least 16 mm diameter and an operating force of (4 ± 1) N, with an accuracy of $\pm 0,05$ mm, for thickness measurements (Z-axis dimension).

3.2 Calliper gauge or any other equivalent tool with an accuracy of $\pm 0,05$ mm for width measurements, and $\pm 0,1$ mm for length measurements.

3.3 Square (straight edge), with arms of at least 300 mm and having a maximum angular deviation of 0,02 mm over 300 mm.

3.4 Set of thickness gauges, ranging from 0,05 mm to 0,10 mm in steps of 0,01 mm, and from 0,10 mm to 1,00 mm in steps of 0,05 mm.

3.5 Steel ruler, of length at least equal to the length of two specimens, and having a maximum straightness deviation of 0,05 mm over 1 000 mm.

3.6 Apparatus for measuring width flatness, consisting of a dial gauge accurate to $\pm 0,01$ mm with a rounded tip of radius $\leq 5,5$ mm, installed centrally in relation to three rounded supports with radii ≥ 5 mm. The supports shall be adjustable along a T-shaped assembly of bars to provide the required gauge length. The measurement, d , shall not be less than the width, w , of the test specimen minus 10 mm. The tip of the gauge in contact with the face of the test specimen shall apply a force of $(1,0 \pm 0,5)$ N. The mass of the apparatus shall not affect the flatness of the test specimen beyond the limit of the accuracy of the gauge. The instrument shall be set to zero against a suitable reference plate. See Figure 1.

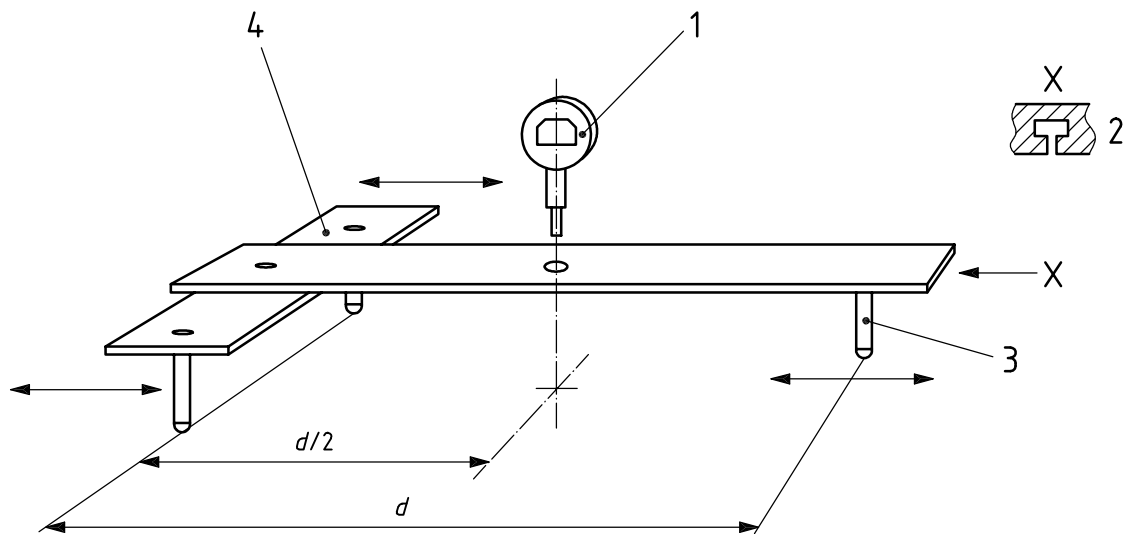

- Key**
- 1 dial gauge
 - 2 T-groove
 - 3 adjustable pin
 - 4 adjustable bridge

Figure 1 — Apparatus for measuring width flatness

3.7 Test surface, of appropriate size that is preferably angled towards the operator by 15° to 30° and in a height suited for standing work. The test surface should be rigid and flat.

4 Test specimens

4.1 General

Test specimens shall be of the nominal size as produced by the manufacturer. The test specimens shall not be restricted from movement during the tests (i.e. bonded to other materials). A specimen under test must be a single sample of nominal manufactured size. All surfaces of a specimen shall be free from foreign bodies and any protrusion from the face and edges. These materials must be removed prior to the start of the test.

4.2 Sampling

Take five laminate floor covering elements as test specimens.

5 Conditioning

Test specimens are normally measured in the received state.

For type approval or verification purposes, the test specimens shall be stabilized to a constant mass in an atmosphere of $(23 \pm 3) ^\circ\text{C}$, $(73 \pm 5) ^\circ\text{F}$ and $(50 \pm 5) \%$ relative humidity. Constant mass is considered to be reached when the results of two successive weighing operations, carried out at an interval of 24 h, do not differ by more than 0,1 % of the mass of the test specimens. If there is any deviation from this conditioning, it shall be stated in the test report.

6 Test procedure

6.1 Determination of thickness (t)

For each of the five specimens, using the micrometer, calliper gauge or any other equivalent tool, measure the thickness, t , at a distance of 20 mm from the edges of the surface layer, at four points located in each corner and at two points in the middle of the specimen at 20 mm from each long side (see Figure 2). Close the jaws gently onto the surfaces between which the thickness is to be measured. Do not force the instrument. Record all 30 measured values to the nearest 0,05 mm.

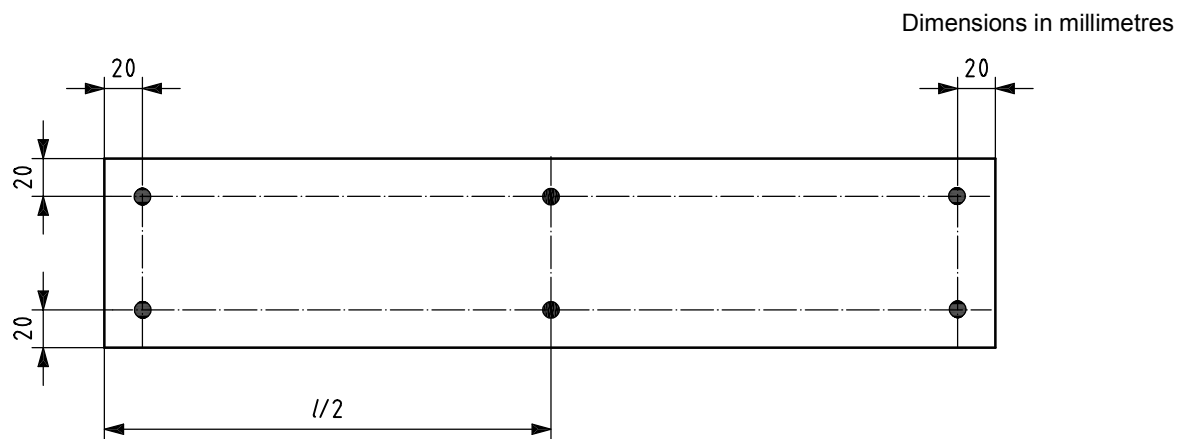

Figure 2 — Measuring points for determination of thickness (t)

6.2 Determination of length (l)

For each of the five specimens, using the appropriate calliper gauge or any other equivalent tool, measure the length, l , of the surface layer along two lines parallel to the axis of the test specimen, at a distance of 20 mm from the long sides (see Figure 3). For squared elements, choose one direction for the measurement. Close the jaws gently onto the edges of the surface layer between which the length is to be measured. Do not force the instrument. Record all 10 measured values to the nearest 0,1 mm.

Dimensions in millimetres

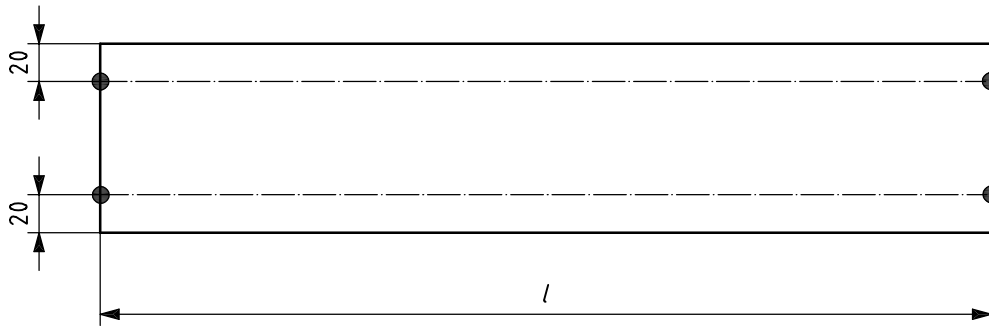

Figure 3 — Measuring points for determination of length (l)

6.3 Determination of width (w)

For each of the five specimens, using the appropriate calliper gauge or any other equivalent tool, measure the width, w , along two lines parallel to the short sides of the surface layer, at a distance of 20 mm from the short sides (see Figure 4). For squared elements, take the direction perpendicular to the direction chosen in 6.2. Close the jaws gently onto the edges of the surface layer between which the width is to be measured. Do not force the instrument. Record all 10 measured values to the nearest 0,05 mm.

Dimensions in millimetres

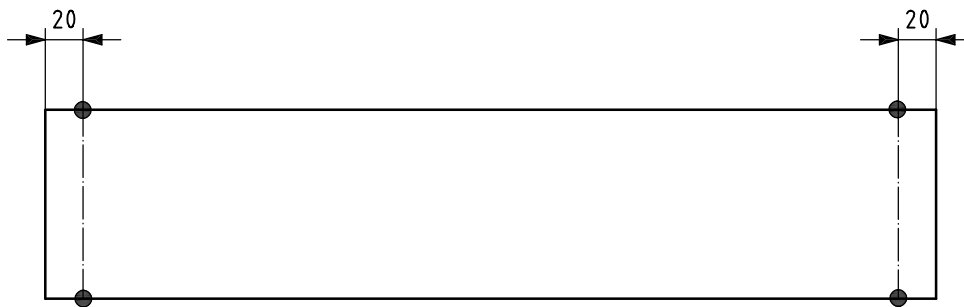

Figure 4 — Measuring points for determination of width (w)

6.4 Determination of squareness (q)

For each of the five specimens, place one side of the square against one long side of the surface layer of the element. Using the thickness gauges, determine the maximum deviation from square q_{max} at the small side. Repeat the procedure on the diagonally opposite corner, see Figure 5. Place the square firmly against the edges of surface layer of the element of which the squareness is to be measured. Do not force the thickness gauges. Record all ten measured values with the result achieved from the appropriate thickness gauge.

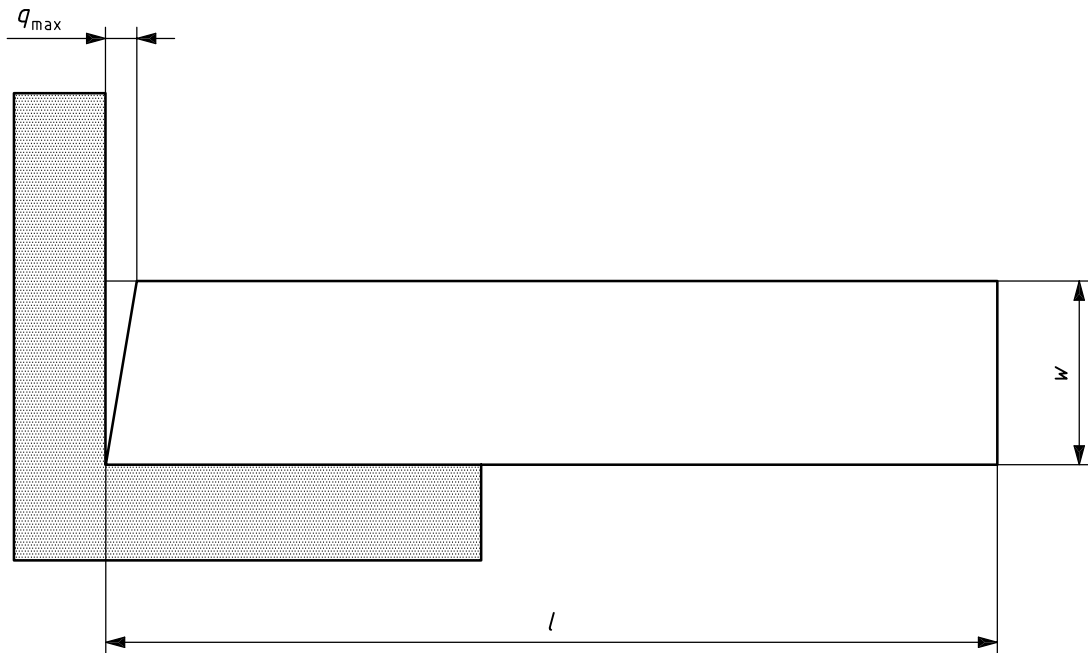

Figure 5 — Determination of squareness (q)

6.5 Determination of straightness (s)

For each of the five specimens, place the specimen with the surface layer up, on the test surface. Place one long side of the surface layer of the specimen firmly against the steel ruler. If a gap is visible, insert vertically a thickness gauge of successive thickness leaves into the gap at the maximum deviation until the largest thickness leaf that will fit without force into the gap is found. This value is the maximum deviation s_{\max} from the ruler. Measure only the position where s_{\max} is found in the centred regions of the panel, see Figure 6. Record all five measured values with the result achieved from the appropriate thickness gauge.

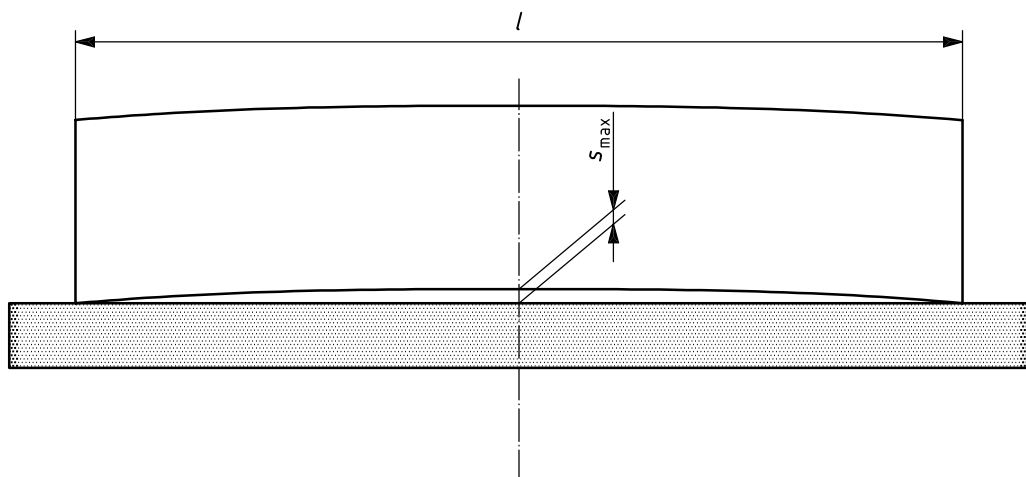

Figure 6 — Determination of straightness (s)

6.6 Determination of width flatness (f_w)

6.6.1 Adjustment and calibration of the apparatus

On the apparatus for measuring width flatness adjust the supports along the T-shaped assembly of bars according to the width of the test specimen to evaluate. The measurement, d , shall be adjusted not be less than the width, w , of the test specimen minus 10 mm, i.e. $d \geq w - 10$ mm (see Figure 9). Use an appropriate calliper gauge and measure the d value. Record the d value to the nearest 0,5 mm.

The apparatus shall be set to, or verified to, zero against the reference plate before each measurement.

6.6.2 Measuring

For each of the five specimens, place the specimen with the surface layer up, on the test surface. Place the adjusted and zeroed apparatus for measuring width flatness on the specimen as shown in Figure 7. Find and determine the maximum deviation of f_w for each element. No force, but the mass of the apparatus, shall affect the flatness of the test specimen when the measurement is taken. The maximum deviation can be either positive or negative, this shall carefully be noticed. Record all five measured values, with their signs, to the nearest 0,01 mm.

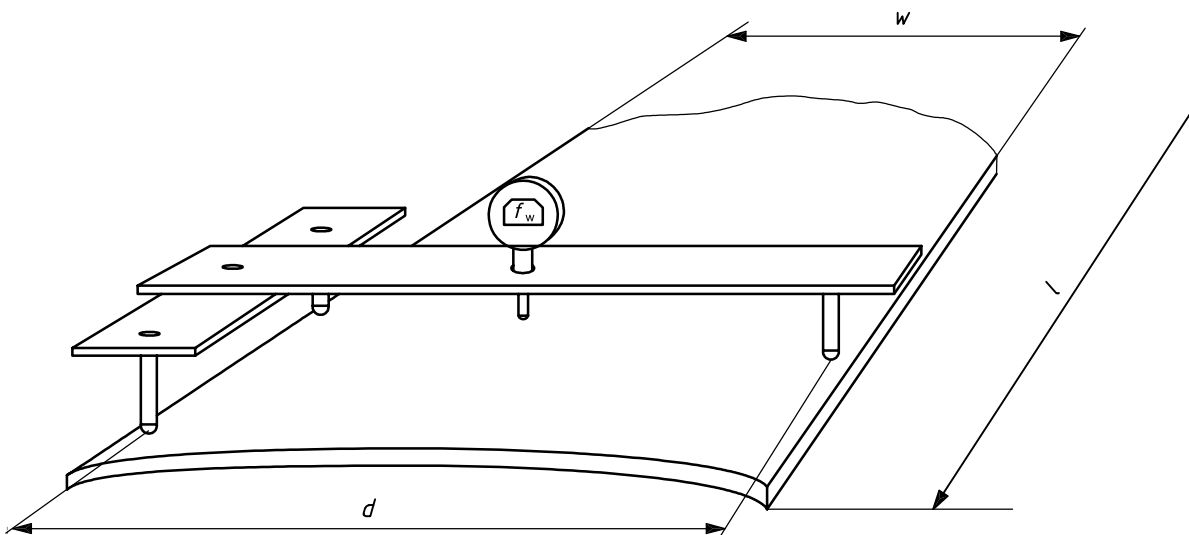
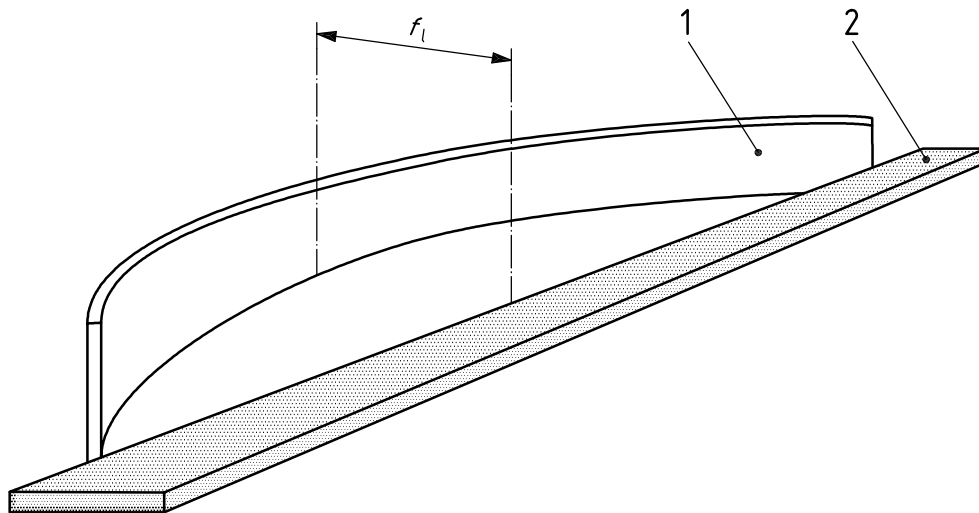

Figure 7 — Determination of width flatness (f_w)

6.7 Determination of length flatness (f_l)

For each of the five specimens, place the test specimen firmly against the steel ruler as shown in Figure 8. If a gap is visible, insert a thickness gauge of successive thickness leaves into the gap at the maximum deviation until the largest thickness leaf that will fit without force into the gap is found. This value is the maximum deviation of f_l . If necessary, use the calliper gauge instead. The measured value shall be expressed as negative when the surface layer is facing towards the ruler and as positive when the surface layer is facing away from the ruler. Record all five measured values, each with its sign, with the result achieved from the appropriate thickness gauge.

**Key**

- 1 test specimen
- 2 steel ruler

Figure 8 — Determination of length flatness (f_l)

6.8 Determination of openings between elements (o)

6.8.1 Assembling

By hand force, without using any glue, against the steel ruler as a guide, firmly assemble seven elements taken as specimens on the test surface as shown in Figure 9. The alignment of the individual elements shall be ensured within ± 5 mm. No difference shall be made whether the joint design is of a glue-less mechanical type, or of a design to be glued or by any other means held together. Glue shall in any case NOT be used for this assembly.

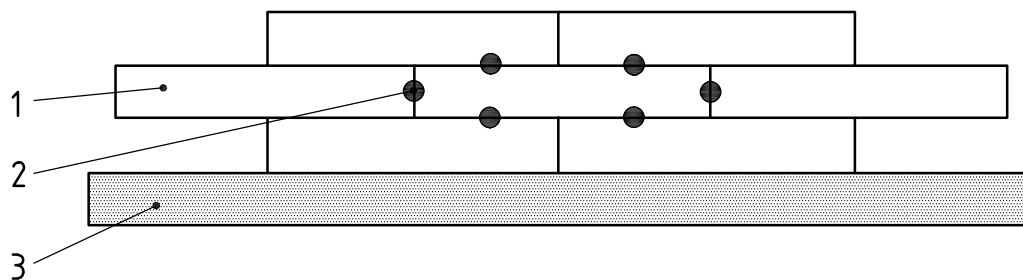
**Key**

- 1 test specimen
- 2 measuring point
- 3 steel ruler

Figure 9 — Test assembly for openings between elements, with the 6 measuring points indicated

6.8.2 Measuring

Using the thickness gauges, measure the openings, without applying any force to the elements, at the six indicated points in Figure 9. Record all six measured values with the result achieved from the appropriate thickness gauge.

6.9 Determination of height difference between elements (*h*)

6.9.1 Assembling

Use the same specimens as from 6.8, assembled as described in 6.8.1. The test assembly with the measuring points is illustrated in Figure 10.

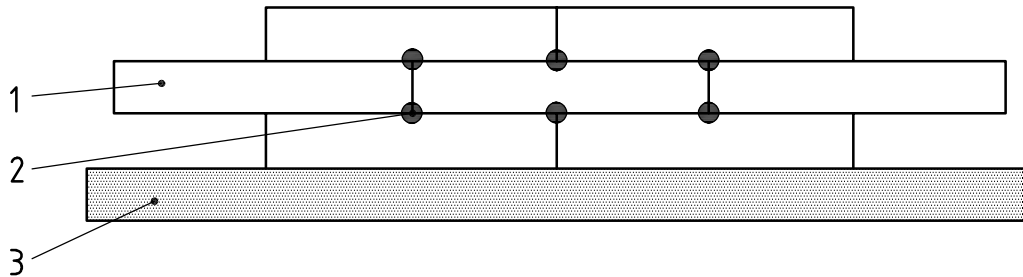

Key

- 1 test specimen
- 2 measuring point
- 3 steel ruler

Figure 10 — Test assembly for height difference between elements, with the 6 measuring points indicated

6.9.2 Measuring

Using the calliper or depth gauge, measure the height differences, without applying any force to the elements, at the six indicated points. Take into account the maximum height difference at either the left side or the right side of the junction. Place the base of the instrument at one side of the joint, and measure the maximum height difference at the other side of the joint. Do not carry out the measurement further than 5 mm from the joint edge. Record all six measured values to the nearest 0,05 mm.

7 Calculations and expression of results

7.1 Thickness (*t*)

Using the 30 measured values of *t*, record the single maximum value t_{\max} and the single minimum value, t_{\min} , and calculate the mean value, t_{avg} .

Calculate $\Delta t_{\text{avg}} = |t_{\text{nom}} - t_{\text{avg}}|$ and $t_{\max} - t_{\min}$ and express the results in millimetres to the nearest 0,05 mm. (Note that t_{nom} is the nominal thickness.)

7.2 Length (*l*)

Using the 10 measured values of *l*, calculate for each value $\Delta l = |l_{\text{nom}} - l|$ and express the results in millimetres to the nearest 0,1 mm.

If $l_{\text{nom}} > 1\,500$ mm, divide Δl by l_{nom} and express the results in millimetres to the nearest 0,1 mm/m.

7.3 Width (*w*)

Using the 10 measured values of *w*, record the single maximum value, w_{\max} , and the single minimum value, w_{\min} , and calculate the mean value, w_{avg} .

Calculate $\Delta w_{\text{avg}} = |w_{\text{nom}} - w_{\text{avg}}|$ and $w_{\text{max}} - w_{\text{min}}$ and express the results in millimetres to the nearest 0,05 mm.

7.4 Squareness (q)

Using the ten measured values of q , take the largest value, q_{max} , and express the result to the nearest 0,05 mm.

7.5 Straightness (s)

Using the five measured values of s , take the largest value and divide it by the nominal length, and express this value, s_{max} , as the result to the nearest 0,05 mm/m.

7.6 Width flatness (f_w)

Using the five measured values of f_w , take the largest positive and/or negative value(s) and divide the value(s) by the recorded distance between the supports on the apparatus, d (see 6.6.1). Express the result(s), with its sign, in percentage to the nearest 0,01 %.

7.7 Length flatness (f_l)

Using the five measured values of f_l , take the largest positive or negative value and divide it by the nominal length of the element. Express the result, in percentage, with its sign to the nearest 0,01 %.

7.8 Openings between elements (o)

Using the six measured values of o , calculate the mean value, o_{avg} . Record the maximum individual value, o_{max} . Express the results in millimetres to the nearest 0,05 mm.

7.9 Height difference between elements (h)

Using the six measured values of h , calculate the mean value, h_{avg} . Record the maximum individual value, h_{max} . Express the results in millimetres to the nearest 0,05 mm.

8 Test report

The test report shall contain at least the following information:

- a) the reference to this International Standard (ISO 24337:2006) and, if any, the deviations;
- b) the name and address of the laboratory that performed the test;
- c) the name and address of the company requesting the test;
- d) the name (brand, if any) and the type of the laminate floor covering tested;
- e) the sampling procedure and date of delivery of the test specimens;
- f) the date and period of the test(s);
- g) the climatic conditions applied to the test specimens prior to testing;
- h) the climatic conditions within the test room during the test;
- i) test results in table format (see example in Annex A).

Annex A (informative)

Example of test results form

An example is given below of a form for the laboratory and test operator to facilitate the recording of all the values, and to express the results in an appropriate way.

Table of test results and calculations — Example

Dimensions in millimetres										
Thickness, t	9,15	9,20	9,15	9,20	9,25	9,25	9,30	9,20	9,20	9,15
	9,20	9,15	9,30	9,15	9,15	9,25	9,15	9,20	9,20	9,20
t_{\max}	9,30									
t_{\min}	9,15									
t_{avg}	9,20									
t_{nom}	9,00									
Δt_{avg}	0,20									
$t_{\max} - t_{\min}$	0,15									
Length, l	1 203,2	1 203,1	1 203,6	1 203,7	1 203,0	1 203,0	1 203,1	1 203,2	1 199,8	1 199,9
l_{nom}	1 200									
Δl	3,20	3,10	3,60	3,70	3,00	3,00	3,10	3,20	0,20	0,10
Width, w	200,05	200,05	200,05	200,00	200,05	200,05	199,95	199,95	200,00	200,00
w_{\max}	200,05									
w_{\min}	199,95									
w_{avg}	200,00									
w_{nom}	200									
Δw_{avg}	0,00									
$w_{\max} - w_{\min}$	0,10									
Squareness, q	0,15	0,15	0,10	0,15	0,20					
q_{\max}	0,20									
Dimensions in millimetres per metre										
Straightness, s	0,08	0,08	0,10	0,12	0,00					
s_{\max}	0,10									

Table of test results and calculations — Example (continued)

Dimensions in millimetres										
Width flatness, f_w	-0,12	-0,13	-0,12	-0,11	0,06					
Distance between supports on apparatus, d	192,50									
Dimensions in percent										
$f_{w,(+)max} / d$	0,03									
$f_{w,(-)max} / d$	-0,07									
Dimensions in millimetres										
Length flatness, f_l	0,20	0,25	0,25	0,30	0,20					
l_{nom}	1 200									
Dimensions in percent										
$f_{l,(+)max} / l_{nom}$	0,03									
$f_{l,(-)max} / l_{nom}$	0,00									
Dimensions in millimetres										
Openings, o	0,05	0,00	0,00	0,05	0,05	0,00				
o_{avg}	0,00									
o_{max}	0,05									
Dimensions in millimetres										
Height difference, h	0,00	0,00	0,02	0,00	0,00	0,00				
h_{avg}	0,00									
h_{max}	0,02									

ICS 79.080; 97.150

Price based on 11 pages
