

First edition
2008-08-01

**Resilient floor coverings — Determination
of dimensional stability and curling after
exposure to heat**

*Revêtements de sol résilients — Détermination de la stabilité
dimensionnelle et de l'incurvation après exposition à la chaleur*



Reference number
ISO 23999:2008(E)

© ISO 2008

PDF disclaimer

This PDF file may contain embedded typefaces. In accordance with Adobe's licensing policy, this file may be printed or viewed but shall not be edited unless the typefaces which are embedded are licensed to and installed on the computer performing the editing. In downloading this file, parties accept therein the responsibility of not infringing Adobe's licensing policy. The ISO Central Secretariat accepts no liability in this area.

Adobe is a trademark of Adobe Systems Incorporated.

Details of the software products used to create this PDF file can be found in the General Info relative to the file; the PDF-creation parameters were optimized for printing. Every care has been taken to ensure that the file is suitable for use by ISO member bodies. In the unlikely event that a problem relating to it is found, please inform the Central Secretariat at the address given below.

Vertical line of dots



COPYRIGHT PROTECTED DOCUMENT

© ISO 2008

All rights reserved. Unless otherwise specified, no part of this publication may be reproduced or utilized in any form or by any means, electronic or mechanical, including photocopying and microfilm, without permission in writing from either ISO at the address below or ISO's member body in the country of the requester.

ISO copyright office
Case postale 56 • CH-1211 Geneva 20
Tel. + 41 22 749 01 11
Fax + 41 22 749 09 47
E-mail copyright@iso.org
Web www.iso.org

Published in Switzerland

Foreword

ISO (the International Organization for Standardization) is a worldwide federation of national standards bodies (ISO member bodies). The work of preparing International Standards is normally carried out through ISO technical committees. Each member body interested in a subject for which a technical committee has been established has the right to be represented on that committee. International organizations, governmental and non-governmental, in liaison with ISO, also take part in the work. ISO collaborates closely with the International Electrotechnical Commission (IEC) on all matters of electrotechnical standardization.

International Standards are drafted in accordance with the rules given in the ISO/IEC Directives, Part 2.

The main task of technical committees is to prepare International Standards. Draft International Standards adopted by the technical committees are circulated to the member bodies for voting. Publication as an International Standard requires approval by at least 75 % of the member bodies casting a vote.

Attention is drawn to the possibility that some of the elements of this document may be the subject of patent rights. ISO shall not be held responsible for identifying any or all such patent rights.

ISO 23999 was prepared by Technical Committee ISO/TC 219, *Floor coverings*.

www.iso.org

Resilient floor coverings — Determination of dimensional stability and curling after exposure to heat

1 Scope

This International Standard specifies a method for determining dimensional stability and curling of resilient floor coverings, in the form of sheets and tiles, in linear dimensions after exposure to heat.

2 Terms and definitions

For the purposes of this document, the following terms and definitions apply.

2.1

dimensional stability

ability of a resilient floor covering to retain its original dimensions after exposure to heat, under specified conditions

2.2

curling

vertical deformation appearing on the specimen after exposure to a heat treatment, under specified conditions

2.3

domed

reverse curl

when centered, area of specimen that does not lie flat against support plate

3 Principle

3.1 Dimensional stability

The relative change in distance between marks or a specific location on a test specimen is measured before and after exposure to a heat treatment, under specified conditions. In the case of tiles, measurements may be made using a block and dial gauge assembly and marking of the test specimen is not necessarily required.

3.2 Curling

The vertical deformations are measured in the test specimen after the specified heat treatment.

Test specimens are placed in an oven at an elevated temperature, after which curl and dimensional stability are determined. In the case of domed material, turn the test specimen over to measure inverted or with the back of the sample facing up. Measure curl and mark appropriately as negative curl.

4 Apparatus

4.1 Oven, thermostatically controlled and ventilated, capable of being maintained at a uniform temperature of 80 ± 2 °C.

In operation, ensure that radiation from the heating element does not directly reach the test specimens or support plates.

4.2 Support plates, of solid metal, e.g. aluminium or stainless steel, of dimensions larger than the test specimen and not less than 1,5 mm in thickness. Ensure that the support plates are kept smooth and polished so that surface friction does not interfere with free shrinkage or growth of the test specimens. The plates shall be flat and free of convex or concave warp.

The shapes and dimensions of the apparatus specified in 4.1 and 4.2 shall be such that:

- a) curling can be measured without removing the test specimens from the support plates, except in the case of domed material;
- b) the clearance between the plates and the vertical walls of the oven is ≥ 50 mm;
- c) the vertical clearance between the support plates and between the plates and the oven is ≥ 100 mm.

4.3 Measuring device.

4.3.1 Measuring equipment (for sheet or tile test specimens): preferably an optical bench, for non-contact measurements. The equipment shall have a range of at least 200 mm and a precision of $\pm 0,02$ mm. For many types of optical benches, take care that the test specimen is properly seated against the base horizontal index guide when a specific measurement is being taken. Test specimens with concave or convex edges can be read incorrectly.

4.3.2 Micrometer (for sheet or tile test specimens), pillar-mounted, or other device accurate to at least 0,1 mm.

4.3.3 Rigid plate (for sheet or tile test specimens), of steel, squared and finished, of dimensions 240 mm \times 240 mm with holes for the scores (see Figure 1).

4.3.4 Square template (for sheet or tile test specimens), of side 610 mm or 508 mm or 305 mm or 229 mm.

Dimensions in millimetres

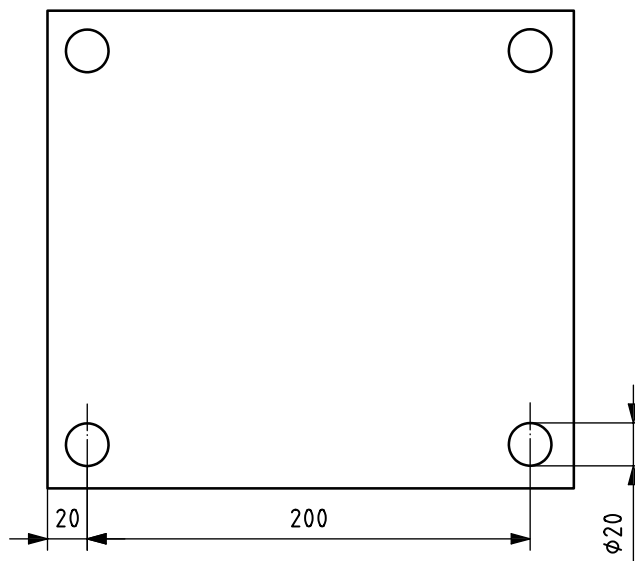
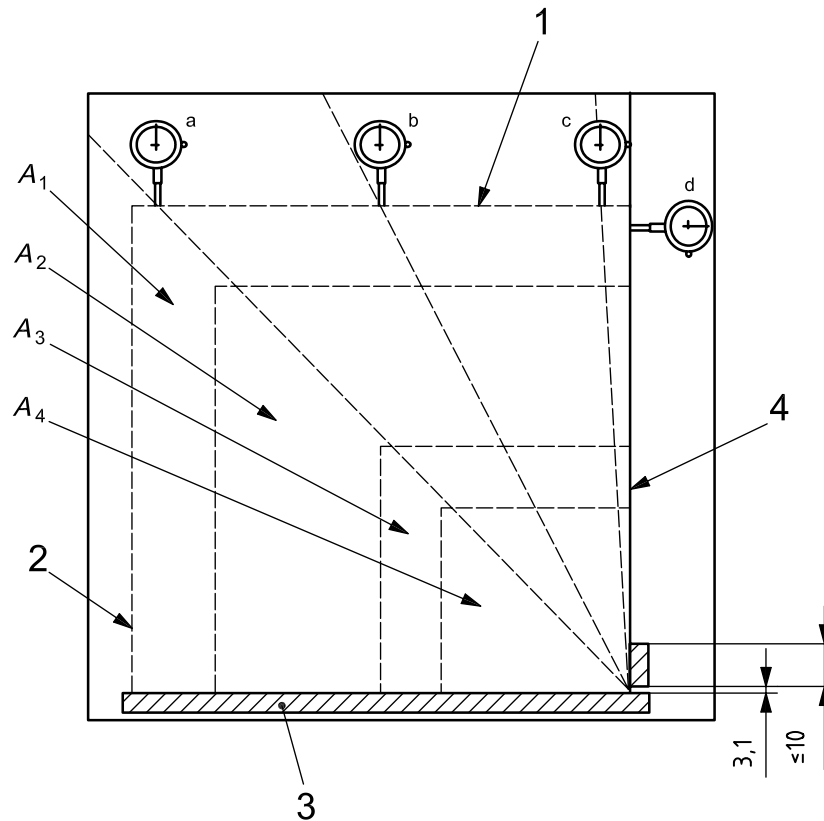

Figure 1 — Rigid steel plate

4.3.5 Block and dial gauge (for tile test specimens only).

See Figure 2.

Dimensions in millimetres



Key

- 1 edge 1
- 2 edge 2
- 3 edge 3
- 4 edge 4

A_1 template 610 mm × 610 mm

A_2 template 508 mm × 508 mm

A_3 template 305 mm × 305 mm

A_4 template 229 mm × 229 mm

- a Within 10 % of the corner of the tile edge.
- b Within the central 10 % of the tile edge.
- c Within 10 % of the corner of the tile edge.
- d Within 10 % of the corner of the tile edge.

Figure 2 — Apparatus for measuring side length, straightness and squareness

4.4 Scoring device, e.g. a single edge razor blade, scalpel or scribe point.

5 Test specimens

For sheet material, before cutting the test specimens, lay out the product as flat as possible and mark the direction of manufacture.

Cut out three (3), nominal 240 mm square test specimens, at equal distance, from the sample material (see Figure 3). The distance between the outer edge of the sample and nearest edge of the test specimen shall be at least 100 mm. The test specimen edges shall be parallel/transverse to the direction of manufacture.

For tiles, remove tiles from package, discard top and bottom tile, spread them out, then randomly select three test specimens. The direction of manufacture shall, if possible, be marked on each test specimen.

Dimensions in millimetres

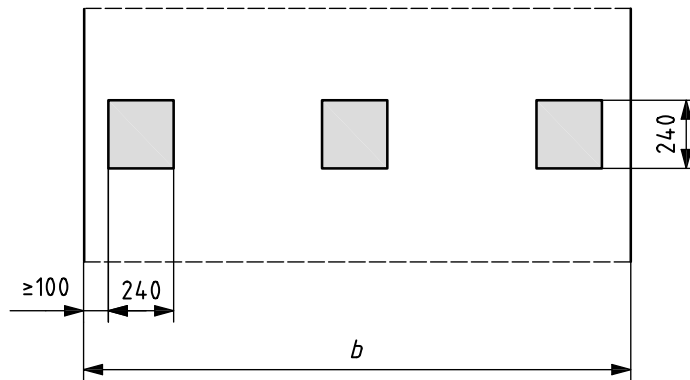

Key

b total width

Figure 3 — Cutting of test specimens

6 Conditioning

Condition test specimens on a flat surface, such as a table surface, to ensure they will contact the support plate uniformly during the measurements.

Condition the test specimens at a temperature of 23 ± 2 °C and relative humidity of 50 ± 5 % for a minimum of 24 h.

7 Test procedure

7.1 Test specimen preparation

Make eight scores (4.4) on each sheet or tile test specimen approximately 20 mm from the edges. Make four scores in each direction to form four crosses, at a distance of 200 ± 1 mm (see Figure 4).

Mark the two reference points for measurement on the top of the test specimen and measure, with the wear surface up, on the block and the optical bench assembly (4.3.1), to ensure that any embossing along the edge of the test specimen wear surface does not affect the measurements.

To make the scores more easily visible, the scores may be marked with a solution of dye in aqueous alcohol (i.e. whiteboard marker or equivalent).

Place each test specimen on a support plate (4.2) with its surface facing upward. Condition the test specimen (see Clause 6).

Dimensions in millimetres

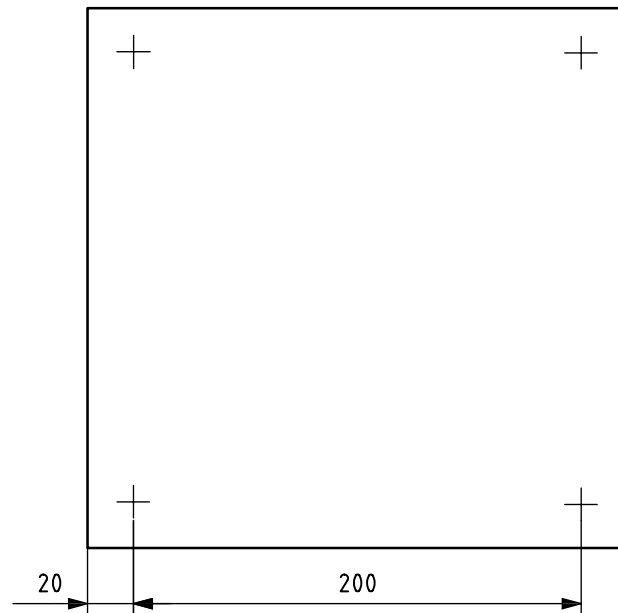

Figure 4 — Scoring of test specimens

7.2 Initial measurement

7.2.1 Curling

Measure the vertical distance between the support plate (4.2) and the wear surface of the test specimen in four places around the edge (usually the corners), where the distance is greatest. Carry out the measurements with the micrometer (4.3.2).

CAUTION — When handling test specimens and making measurements, to avoid distortion, do not apply undue force to the test specimen.

7.2.2 Linear dimensions

On each test specimen, determine the length of four measurement sections: two in the manufacturing direction (MD) of the flooring material; and two in the transverse or across-manufacturing (TD or AMD) direction.

Put the rigid plate (4.3.3) on top of the test specimen and measure the length between the crosses formed by the scores (see Figure 1).

Start the heat exposure portion of the test within 1 h of making the initial dimensional measurements.

7.3 Heat exposure

Place the test specimens horizontally on to support plates (4.2), previously placed in the oven (4.1), and allow to come to $(80 \pm 2) ^\circ\text{C}$. Maintain the test specimens at this temperature for $6 \text{ h } ^{+15}_0 \text{ min}$ in the oven.

7.4 Reconditioning

Remove the test specimens from the oven. Allow the test specimens to recondition (see Clause 6) for 24 h (unless otherwise specified for the product). Do not remove the test specimens from the metal plate until the reconditioning time has elapsed and the measurements are to be performed.

7.5 Final measurement

After reconditioning, measure the dimensional changes to the test specimen.

7.5.1 Curling

Re-measure curling as described in 7.2.1. Make sure that the optical device (4.3.1) is at the same reference points for both the initial and final measurements.

7.5.2 Linear dimensions

7.5.2.1 For sheet and tile test specimens

Make sure to place the rigid metal plate on top of the specimens and re-measure the length between the crosses formed by the scores, i.e. the new distance of each measurement section (see Figure 1). Make sure that the optical device (4.3.1) is at the same reference points for both the initial and final measurements.

7.5.2.2 For tile test specimens measured using block and dial gauge

Place the test specimen on the block and dial gauge (4.3.5). Record the length at the specified location (see Figure 2).

8 Calculation and expression of results

8.1 Curling

Calculate the mean value of the four differences for each test specimen and the mean value for the three test specimens. Express the results in millimetres to the nearest 0,5 mm.

8.2 Dimensional stability

For each of the test directions, record the variations for the six length measurements (two readings from three test specimens). Calculate the dimensional change for each measurement section related to the initial length. The linear change, expressed as a percentage, is given by Equation (1):

$$\frac{(L_0 - L_1)}{L_0} \times 100 \quad (1)$$

where

L_0 is the initial length (7.2.2);

L_1 is the length after test (7.5.2).

For each of the test directions, calculate the mean value of the six results and express it both as a percentage to the nearest 0,05 % and as the change in length in millimetres.

9 Precision

No data currently available.

10 Test report

The test report shall include at least the following information:

- a) the test method used, together with reference to this International Standard, i.e. ISO 23999;
- b) date(s) on which the tests were carried out;
- c) all the information required for the complete identification of the product tested, including type, source, colour, and manufacturer's reference number(s);
- d) previous history of the sample from which the test specimens were drawn;
- e) all operating details not specified in this International Standard, or regarded as optional, together with details of any incident that may have influenced the result(s);
- f) the test results obtained, as changes in dimensions:
 - 1) the mean value of linear change in dimension for each direction,
 - 2) the maximum values for each direction,
 - 3) the mean value for curling,
 - 4) the mean value for initial curling, if any;
- g) if normal change in dimensions did not occur, describe any deviation from the method specified in this International Standard which may have affected the results.

Bibliography

- [1] ASTM F2055, *Standard test method for size and squareness of resilient floor tile by dial gage method*
- [2] ASTM F2199, *Standard test method for determining dimensional stability of resilient floor tile after exposure to heat*
- [3] EN 427, *Resilient floor coverings — Determination of the side length, squareness and straightness of tiles*
- [4] EN 434, *Resilient floor coverings — Determination of dimensional stability and curling after exposure to heat*
- [5] JIS A 1454, *Test methods — Resilient floorcoverings*¹⁾

1) See “Test of length due to heating” (6.7).

.....

1

ICS 97.150

Price based on 8 pages