Machine tools — Ball splines —

Part 1:

General characteristics and requirements

Machines-outils — Guidages cannelés à billes —

Partie 1: Exigences et caractéristiques générales



Reference number
ISO 23848-1:2009(E)

© ISO 2009

PDF disclaimer

This PDF file may contain embedded typefaces. In accordance with Adobe's licensing policy, this file may be printed or viewed but shall not be edited unless the typefaces which are embedded are licensed to and installed on the computer performing the editing. In downloading this file, parties accept therein the responsibility of not infringing Adobe's licensing policy. The ISO Central Secretariat accepts no liability in this area.

Adobe is a trademark of Adobe Systems Incorporated.

Details of the software products used to create this PDF file can be found in the General Info relative to the file; the PDF-creation parameters were optimized for printing. Every care has been taken to ensure that the file is suitable for use by ISO member bodies. In the unlikely event that a problem relating to it is found, please inform the Central Secretariat at the address given below.



COPYRIGHT PROTECTED DOCUMENT

© ISO 2009

All rights reserved. Unless otherwise specified, no part of this publication may be reproduced or utilized in any form or by any means, electronic or mechanical, including photocopying and microfilm, without permission in writing from either ISO at the address below or ISO's member body in the country of the requester.

ISO copyright office
Case postale 56 • CH-1211 Geneva 20
Tel. + 41 22 749 01 11
Fax + 41 22 749 09 47
E-mail copyright@iso.org
Web www.iso.org

Published in Switzerland

Contents

Page

Foreword	iv
Introduction.....	v
1 Scope	1
2 Normative references	1
3 Terms and definitions	1
4 Classification and grade	2
5 Characteristics	4
5.1 Groove twist of the spline shaft	4
5.2 Spline shaft accuracy	4
5.3 Spline outer race mounting accuracy	4
5.4 Total radial runout of the spline shaft in relation to the axis of the support journals	5
5.5 Hardness	5
6 Shapes and dimensions	10
7 Test methods	10
7.1 Test environment	10
7.2 Groove twist	10
7.3 Accuracy of the spline shaft	11
7.4 Accuracy of the spline outer race mounting	13
7.5 Total radial runout of the spline shaft in relation to the axis of the support journals	13
7.6 Hardness	15
8 Inspection	15
9 Designation	15
10 Marking	16
Annex A (normative) Shapes and dimensions of the spline outer races	17

Foreword

ISO (the International Organization for Standardization) is a worldwide federation of national standards bodies (ISO member bodies). The work of preparing International Standards is normally carried out through ISO technical committees. Each member body interested in a subject for which a technical committee has been established has the right to be represented on that committee. International organizations, governmental and non-governmental, in liaison with ISO, also take part in the work. ISO collaborates closely with the International Electrotechnical Commission (IEC) on all matters of electrotechnical standardization.

International Standards are drafted in accordance with the rules given in the ISO/IEC Directives, Part 2.

The main task of technical committees is to prepare International Standards. Draft International Standards adopted by the technical committees are circulated to the member bodies for voting. Publication as an International Standard requires approval by at least 75 % of the member bodies casting a vote.

Attention is drawn to the possibility that some of the elements of this document may be the subject of patent rights. ISO shall not be held responsible for identifying any or all such patent rights.

ISO 23848-1 was prepared by Technical Committee ISO/TC 39, *Machine tools*.

ISO 23848 consists of the following parts, under the general title *Machine tools — Ball splines*:

- *Part 1: General characteristics and requirements*
- *Part 2: Dynamic and static load ratings and rating life*

Introduction

The ball spline is a power transmission component based on recirculating balls, which is designed to translate axially while transmitting torque by an anti-friction means. The ball spline is selected for its smooth operation, high speed capability, low friction and high-radial and high-torsional load capacity.

This part of ISO 23848 specifies and standardizes the following characteristics of ball splines:

- the shapes and dimensions;
- the test methods;
- the inspection;
- the designation;
- the marking.

ISO 23848-2 specifies and standardizes the following properties of ball splines:

- the basic static and dynamic load ratings;
- the basic static and dynamic torque ratings;
- the rating life.

Vertical line of text on the right side of the page.

Machine tools — Ball splines —

Part 1: General characteristics and requirements

1 Scope

This part of ISO 23848 specifies and standardizes the following characteristics for ball splines:

- the shapes and dimensions;
- the test methods;
- the inspection;
- the designation;
- the marking.

2 Normative references

The following referenced documents are indispensable for the application of this document. For dated references, only the edition cited applies. For undated references, the latest edition of the referenced document (including any amendments) applies.

ISO 554, *Standard atmospheres for conditioning and/or testing — Specifications*

ISO 6507-1, *Metallic materials — Vickers hardness test — Part 1: Test method*

ISO 6507-2, *Metallic materials — Vickers hardness test — Part 2: Verification and calibration of testing machines*

3 Terms and definitions

For the purposes of this document, the following terms and definitions apply.

NOTE See Figure 1.

3.1 ball spline

machine element consisting of the spline shaft, spline outer race, balls and recirculation devices and seals, for providing smooth relative axial motion between the shaft and the outer race, while preventing their relative rotation for the purpose of transmitting torque

- 3.2**
effective spline length
actual available length of axial travel for the spline outer race on the spline shaft
- 3.3**
groove twist of the ball spline
value of rotational deviation of the spline outer race over the effective travel length
- 3.4**
nominal diameter of the spline shaft
outer diameter of the spline shaft representing the size of the ball spline without tolerance, sometimes expressed as the pitch circle diameter without tolerance
- NOTE The pitch circle diameter, D_p , refers to the diameter specifying the location of the rolling ball centres in the ball spline assembly with their theoretical contacts on the groove surfaces of both the spline shaft and the spline outer race.
- 3.5**
spline groove
groove ground or rolled along the axial direction on the shaft periphery or the inner surface of the spline outer race to facilitate the smooth rolling of balls inside the assembly
- 3.6**
spline outer race
assembly comprising the body with internal spline grooves, balls, recirculation devices and/or additional embodiments
- 3.7**
spline shaft
shaft consisting of axial spline grooves, which are matched with the grooves of a compatible spline outer race and can accommodate recirculating balls

4 Classification and grade

Ball splines shall be classified as type A (angular) or type R (radial), as shown in Figure 1 and Table 1. Each ball spline type shall be divided into three grades, C1, C3 and C5, according to the quality and precision and may be represented by symbols such as:

- P for C1;
- H for C3;
- no symbol for C5.

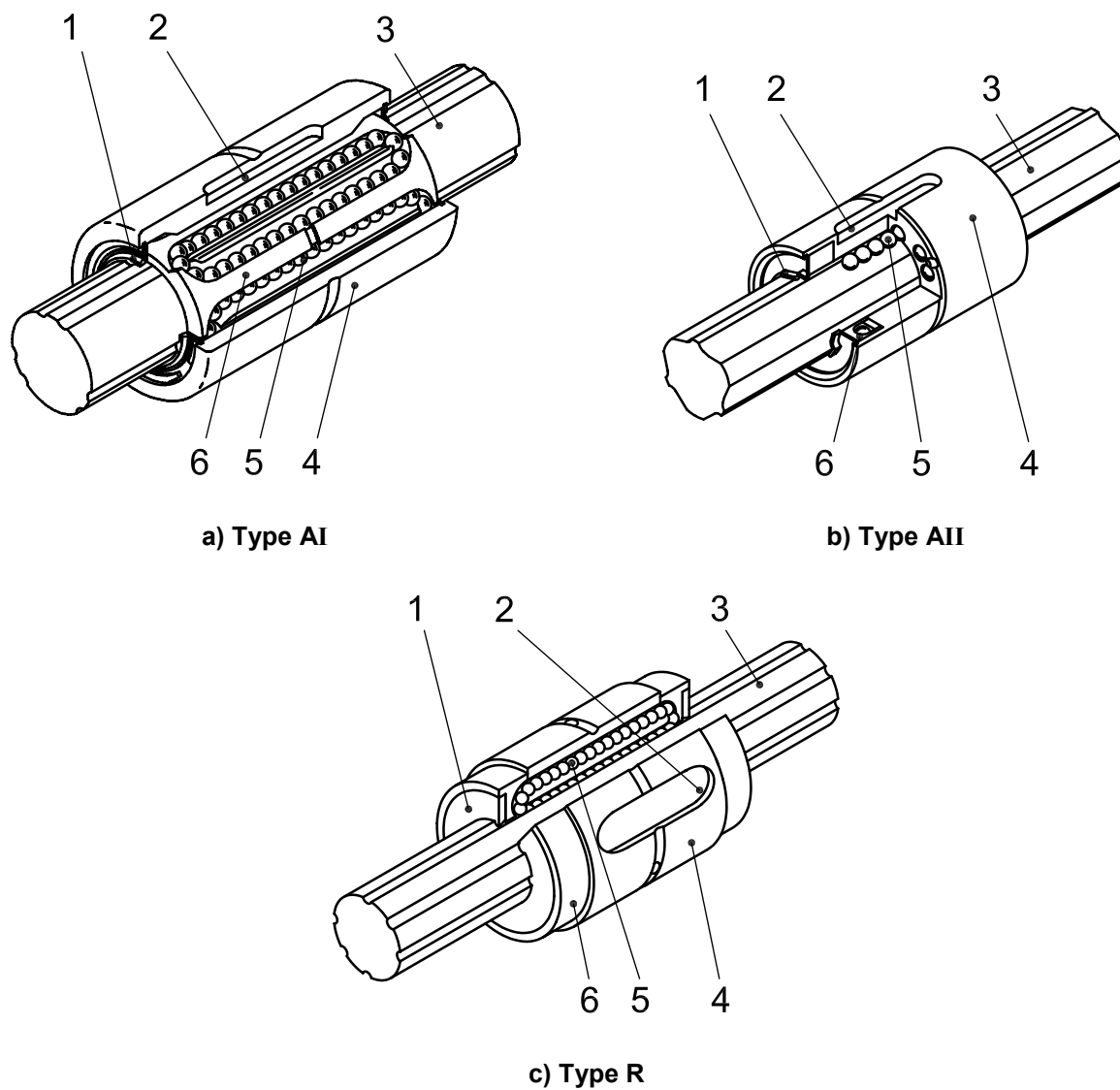

Key

- 1 seal
- 2 keyway
- 3 spline shaft
- 4 spline outer race
- 5 balls
- 6 retainer and/or end cap

NOTE These drawings are examples of a construction.

Figure 1 — Names of the parts of typical ball splines

Table 1 — Type and symbol of ball splines

Name	Type	Flange on the spline outer race	Seal	
Ball spline	AI	without	without	
			with	one side (U) ^a
	both sides (UU) ^a			
	AII	with (F) ^a	without	
			with	one side (U) ^a
	both sides (UU) ^a			
^a Letters in parentheses in this table are indication symbols, the application of which is given in Clause 9.				

5 Characteristics

5.1 Groove twist of the spline shaft

The tolerance on the groove twist of a ball spline, when measured by the method given in 7.2, shall meet the requirement of Table 2 with respect to 100 mm taken at random within the effective spline length.

In cases where it is impossible to take 100 mm or more relative travel distance between the spline shaft and spline outer race, apply a converted value of Table 2 in proportion to the travel distance.

Table 2 — Groove twist of the ball spline

Grade	Dimensions in micrometres		
	C1	C3	C5
Twist tolerance (max.)	6	13	33
NOTE See Figure 3.			

5.2 Spline shaft accuracy

The radial runout of the spline grooves, part mounting journals and the axial runout of the end face of the spline shaft in relation to the axis of support journals of the spline shaft, when measured by the methods given in 7.3.1 to 7.3.3, shall meet the specifications in Tables 3 to 5, respectively (see Figures 2, 4, 5 and 6).

5.3 Spline outer race mounting accuracy

The axial runout of the spline outer race reference face or the flange mounting face of the flange, and the radial runout of the spline outer race in relation to the axis of the spline shaft, when measured using the methods given in 7.4.1 and 7.4.2, shall meet the specifications in Tables 6 and 7, respectively (see Figures 2, 7 and 8).

NOTE Figures 2 to 9 typically show type AI, as an example.

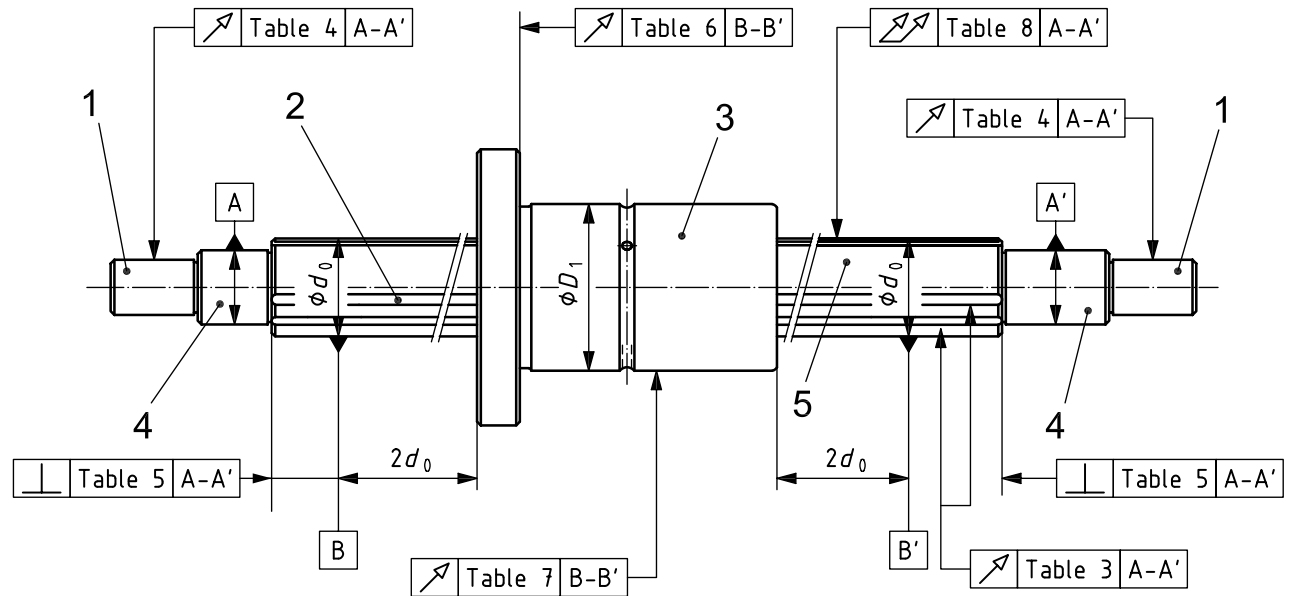

Key

- 1 part mounting journal
- 2 spline groove
- 3 spline outer race
- 4 support journal
- 5 spline shaft

NOTE 1 The support journals refer to the portions, where bearings will support the spline shaft.

NOTE 2 The part mounting journals refer to the portions intended for mounting a gear wheel or other machine elements.

NOTE 3 Not applicable to those without support journals and/or part mounting journal.

Figure 2 — Accuracy of the ball spline

5.4 Total radial runout of the spline shaft in relation to the axis of the support journals

The tolerance on the total radial runout of the spline shaft in relation to the axis of the support journals, when measured using the method given in 7.5, shall meet the specifications in Table 8 (see Figures 2 and 9).

5.5 Hardness

The hardness of spline groove surfaces, when determined according to the method given in 7.6, shall be at least ≥ 653 HV (≥ 58 HRC).

Table 3 — Radial runout of the spline grooves in relation to the axis of the support journals

Nominal diameter, d_0 mm		Runout tolerance μm max. ^a		
		Grade		
Over	Up to and including	C1	C3	C5
—	8	8	14	33
8	12	10	17	41
12	20	12	19	46
20	32	13	22	53
32	50	15	25	62
50	80	17	29	73
80	125	20	34	86

NOTE See Figure 4.

^a As the influence of the runouts of the axis of the spline shaft is included in this value, a correction is needed. For the correction, obtain the correction value from Table 8 for the total runout tolerance on the shaft support journals corresponding to the ratio of the total shaft length to the measured distance between the points of support and add it to the tolerance in Table 3 to apply.

Table 4 — Radial runout of the part mounting journals in relation to the axis of the support journals

Nominal diameter, d_0 mm		Runout tolerance μm max.		
		Grade		
Over	Up to and including	C1	C3	C5
—	8	8	14	33
8	12	10	17	41
12	20	12	19	46
—	—	—	—	—
20	32	13	22	53
32	50	15	25	62
50	80	17	29	73
80	125	20	34	86

NOTE See Figure 5.

Table 5 — Axial runout of the end faces of the spline shaft in relation to the axis of the support journals

Nominal diameter, d_0 mm		Runout tolerance		
		μm max.		
		Grade		
Over	Up to and including	C1	C3	C5
—	8	6	9	22
8	12	6	9	22
12	20	8	11	27
—	—	—	—	—
20	32	9	13	33
32	50	11	16	39
50	80	13	19	46
80	125	15	22	54

NOTE See Figure 6.

Table 6 — Axial runout of the spline outer race reference face or the flange mounting face in relation to the axis of the spline shaft

Nominal diameter of the spline outer race, D_1 mm		Runout tolerance		
		μm max.		
		Grade		
Over	Up to and including	C1	C3	C5
—	18	8	11	27
18	30	9	13	33
30	50	11	16	39
—	—	—	—	—
50	80	13	19	46
80	120	15	22	54
120	180	18	25	63
180	250	20	29	72

NOTE See Figure 7.

Table 7 — Radial runout of the spline outer race in relation to the axis of the spline shaft

Nominal diameter of the spline outer race, D_1 mm		Runout tolerance		
		μm max.		
		Grade		
Over	Up to and including	C1	C3	C5
—	18	5	11	27
18	30	6	13	33
30	50	7	16	39
—	—	—	—	—
50	80	8	19	46
80	120	10	22	54
120	180	12	25	63
180	250	14	29	72

NOTE See Figure 8.

Table 8 — Total radial runout of the spline shaft in relation to the axis of the support journals

Grade		C1					C3					C5										
Nominal diameter, d_0 mm	Over	8	12	20	32	50	80	—	8	12	20	32	50	80	—	8	12	20	32	50	80	
	Up to and including	8	12	20	32	50	80	125	8	12	20	32	50	80	125	8	12	20	32	50	80	125
Nominal length of the spline shaft mm		Runout tolerances μm max.										Runout tolerances μm max.										
Over	Up to and including	26	20	18	18	16	16	16	16	16	16	16	16	16	16	16	16	16	16	16	16	16
—	200	26	20	18	18	16	16	16	16	16	16	16	16	16	16	16	16	16	16	16	16	16
200	315	57	32	25	21	19	19	17	17	17	17	17	17	17	17	17	17	17	17	17	17	17
315	400	82	41	31	25	21	19	17	17	17	17	17	17	17	17	17	17	17	17	17	17	17
400	500	108	51	38	29	24	21	19	163	82	62	50	43	38	35	236	123	95	78	68	61	57
500	630		65	46	34	27	23	20		102	75	57	47	41	37		151	112	88	74	65	60
630	800		85	58	42	32	26	22		130	92	68	54	45	40		190	137	103	84	71	64
800	1 000			75	52	38	30	24			115	83	63	51	43			170	124	97	79	69
1 000	1 250				65	47	35	28				102	76	59	48				151	114	90	76
1 250	1 600				85	59	43	33				130	93	70	55				190	139	106	86
1 600	2 000					77	54	40				118		86	65					173	128	99
2 000	2 500						68	49					106	78							156	117
2 500	3 150						88	61					134	96							190	143

NOTE See Figure 9.

6 Shapes and dimensions

For ball splines, the nominal diameter of the spline shaft and the shape and boundary dimensions of various spline outer races are given in Annex A.

7 Test methods

7.1 Test environment

Use 20 °C as the standard temperature condition specified in ISO 554, with the tolerance specified as class 15.

7.2 Groove twist

With the spline shaft fixed at the support journals and the test dial indicator placed on the side surface of the key of the outer race, or on the notched side surface of the measuring attachment mounted on the spline outer race perpendicular to the shaft axis, as shown in Figure 3, apply a suitable torque in one direction to the spline outer race and measure the runout by moving the outer race and the probe simultaneously in the axial direction for a distance of 100 mm anywhere within the effective length of the spline shaft. Take this value as the runout due to the twist in the spline groove of the ball spline. The test dial indicator shall be placed on the portion as close as possible to the spline outer race.

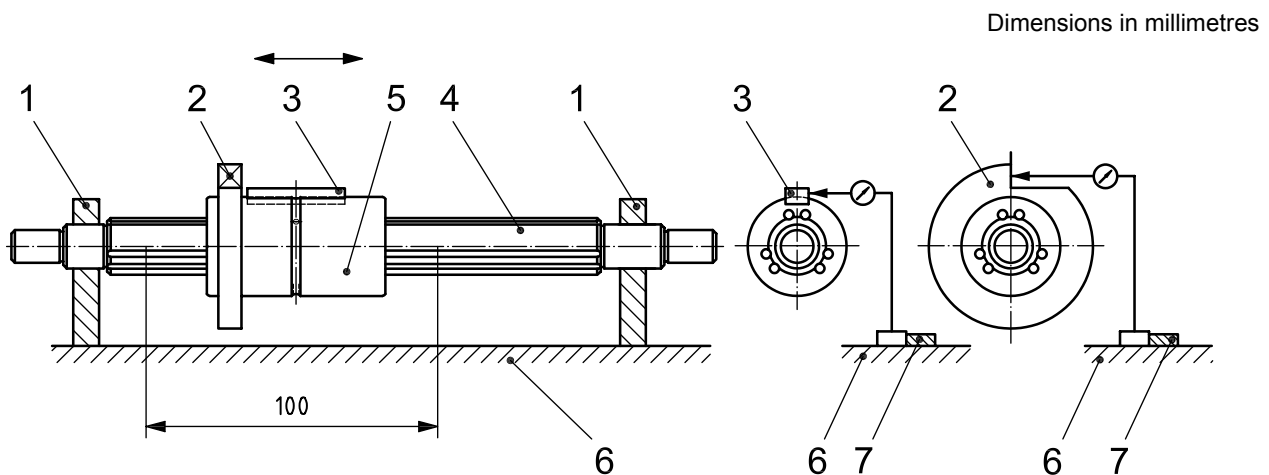

Key

- 1 fixed support
- 2 measuring attachment
- 3 key
- 4 spline shaft
- 5 spline outer race
- 6 surface plate
- 7 reference block

Figure 3 — Groove twist of the ball spline

7.3 Accuracy of the spline shaft

7.3.1 Radial runout of the spline grooves in relation to the axis of the support journals

The spline shaft shall be supported on two V-blocks at the support journals and pin gauges of a diameter the same as the ball diameter used in the spline grooves shall be held in contact with the groove surface by a fixing jig, as shown in Figure 4. Place the dial test indicator on the pin gauge and obtain the maximum measured deviation value for one full turn of the spline shaft in relation to the axis of the support journals.

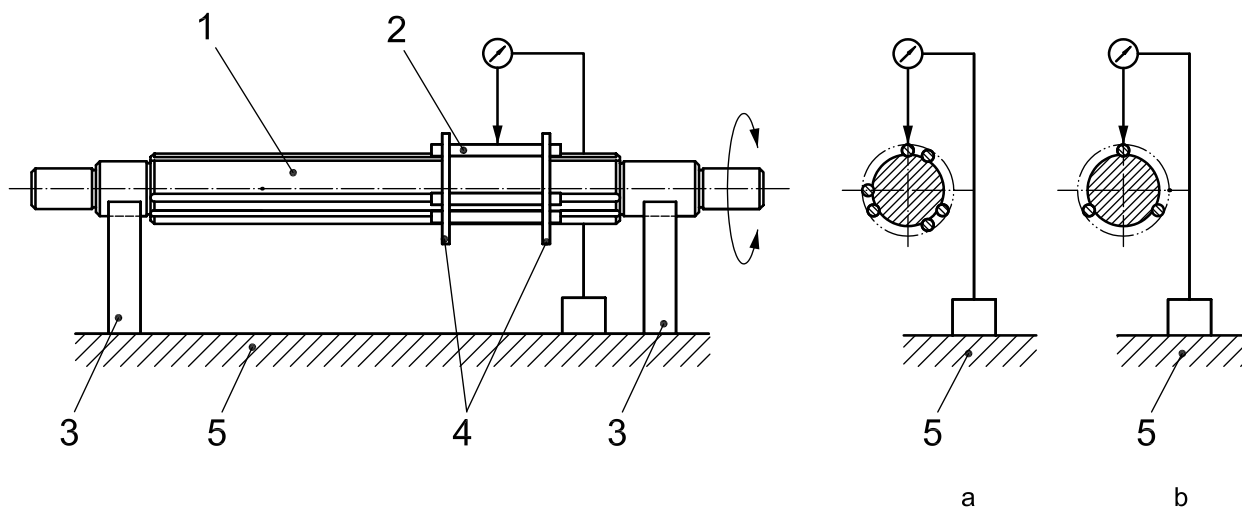

Key

- 1 spline shaft
- 2 pin gauge
- 3 V-block
- 4 fixture jig
- 5 surface plate
- a Type AI/AII.
- b Type R.

Figure 4 — Radial runout of the spline grooves in relation to the axis of the support journals

7.3.2 Radial runout of the part mounting journals in relation to the axis of the support journals

With the spline shaft supported horizontally on two V-blocks at the support journals, as shown in Figure 5, obtain the runout of the part mounting journals by placing the dial test indicator on both support journals, while rotating the spline shaft for one full turn.

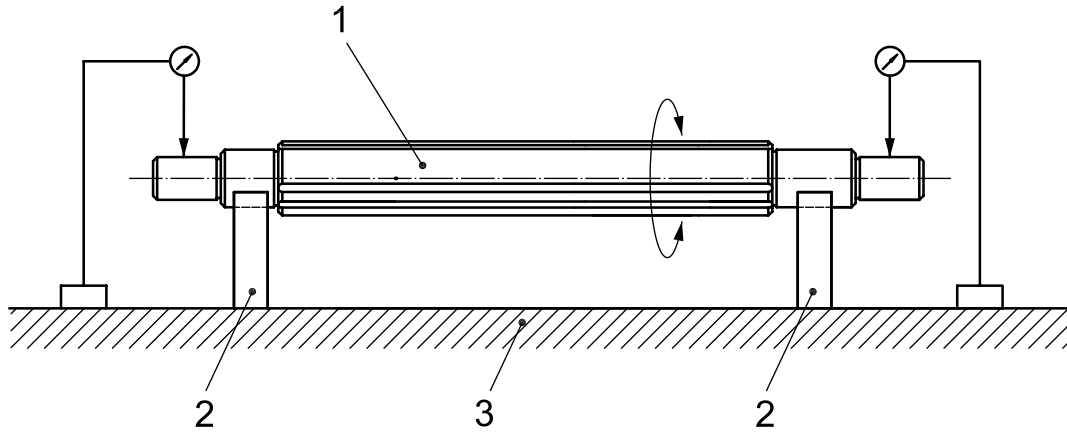

Key

- 1 spline shaft
- 2 V-block
- 3 surface plate

Figure 5 — Radial runout of the part mounting journals in relation to the axis of the support journals

7.3.3 Axial runout of the end faces of the spline shaft in relation to the axis of the support journals

With the spline shaft pushed to one end against a rigid wall with a ball in between, while being supported horizontally on two V-blocks at the support journals, as shown in Figure 6, measure the runouts by placing the dial test indicator against the vertical faces of the spline shaft on both sides for one full turn of the spline shaft.

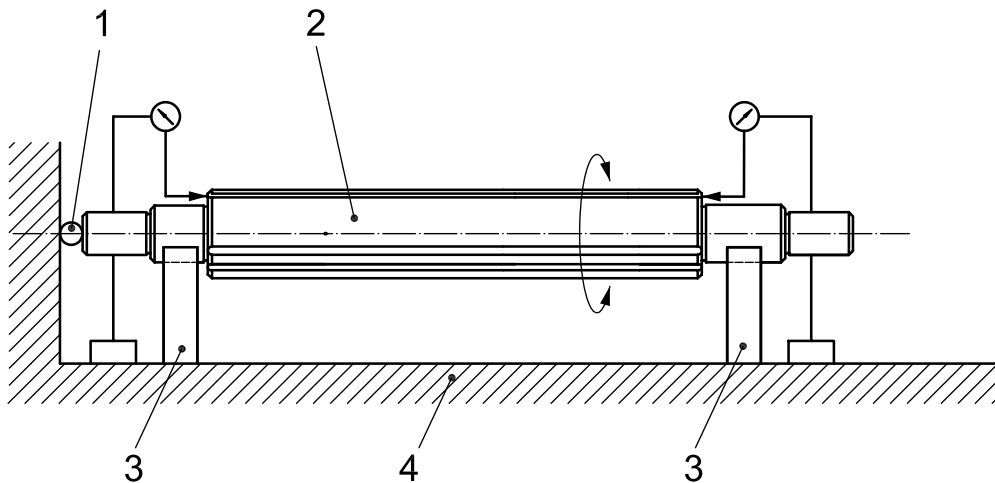

Key

- 1 ball
- 2 spline shaft
- 3 V-block
- 4 surface plate

Figure 6 — Axial runout of the end faces of the spline shaft in relation to the axis of the support journals

7.4 Accuracy of the spline outer race mounting

7.4.1 Axial runout of the spline outer race reference face or the flange mounting face in relation to the axis of the spline shaft

With the spline outer race fixed on the spline shaft by means of fixtures on both sides, the spline shaft supported on two V-blocks located at a distance of $2d_0$ (twice the spline shaft nominal diameter) from both ends of the spline outer race, and one end of the spline shaft pushed against a rigid wall with a ball in between, as illustrated in Figure 7, place the dial test indicator probe against the reference side of the spline outer race flange end face and measure the axial runout of the spline outer race in relation to the axis of the spline shaft while rotating for one full turn. The measurement may be made while supporting the spline shaft at the centre holes on both ends.

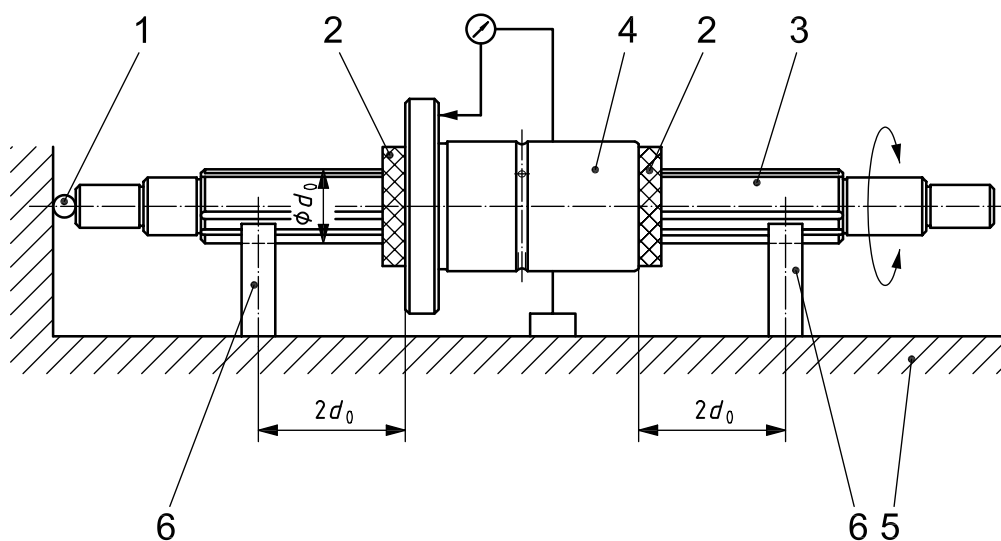

Key

- 1 ball
- 2 fixture jig
- 3 spline shaft
- 4 spline outer race
- 5 surface plate
- 6 V-block

Figure 7 — Axial runout of the spline outer race reference face or the flange mounting face in relation to the axis of the spline shaft

7.4.2 Radial runout of the spline outer race in relation to the axis of the spline shaft

With the spline outer race fixed on the spline shaft by means of fixtures and the spline shaft supported on two V-blocks located on both sides at a distance of $2d_0$ (twice the spline shaft nominal diameter) from both ends of the spline outer race edges, as illustrated in Figure 8, place the probe of the dial test indicator at several places on the spline outer race and determine the maximum value of the runouts while rotating the spline outer race together with the spline shaft.

7.5 Total radial runout of the spline shaft in relation to the axis of the support journals

With the spline shaft supported horizontally at its support journals on two V-blocks, as illustrated in Figure 9, place the probe of the dial test indicator approximately coinciding with the centre of the spline shaft, and measure the runouts on several positions along the axial direction for one full rotation of the shaft; take the maximum value as the total runout. As agreed between the purchaser and the manufacturer, this measurement may be made while supporting the shaft at the centre holes on both ends.

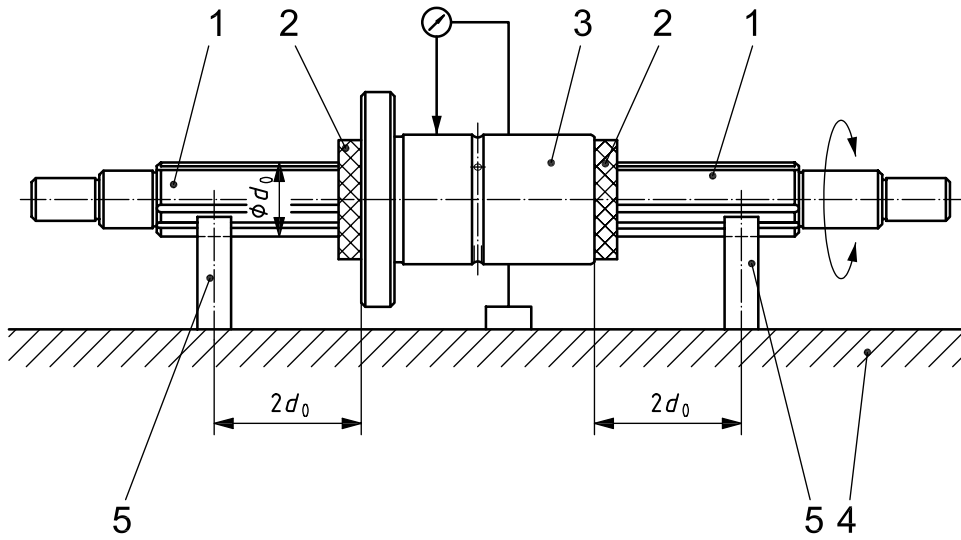

Key

- 1 spline shaft
- 2 fixture jig
- 3 spline outer race
- 4 surface plate
- 5 V-block

Figure 8 — Radial runout of the spline outer race in relation to the axis of the spline shaft

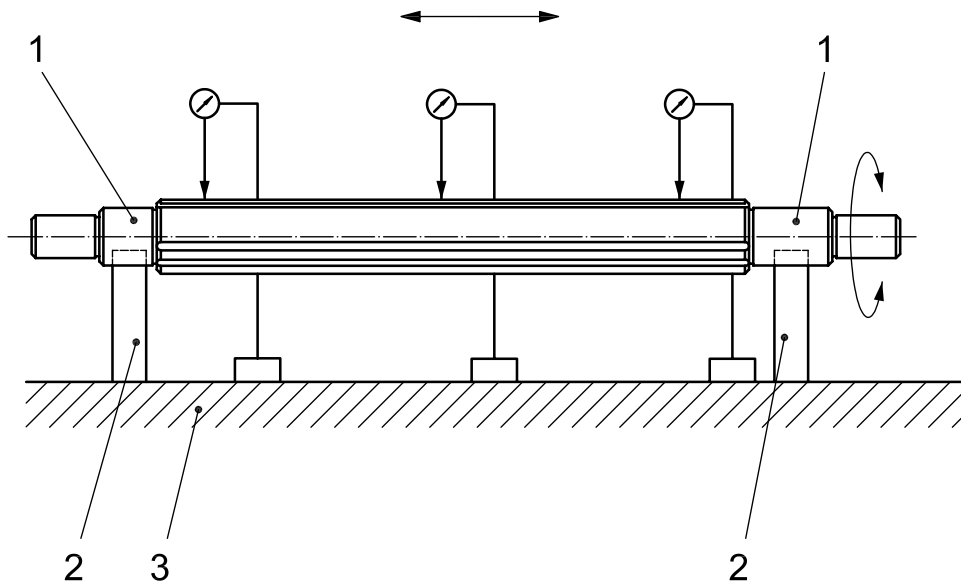

Key

- 1 support journal
- 2 V-block
- 3 surface plate

Figure 9 — Total radial runout of the spline shaft in relation to the axis of the support journals

7.6 Hardness

The hardness test shall be carried out in accordance with ISO 6507-1, by using a testing device as defined in ISO 6507-2 and such measurements shall be made on the spline shaft, as well as on the end face near a spline groove of the outer race body.

8 Inspection

Ball splines shall be inspected for the appearance, accuracy and hardness, and shall meet the specifications given in Clauses 5, 6 and 10.

9 Designation

Ball splines shall be designated by the following:

- a) the number (or title) of this part of ISO 23848, i.e. ISO 23848-1:2009;
- b) the symbol of classification;
- c) the number of spline grooves (to be followed by the symbol N);
- d) the nominal size;
- e) the spline groove length;
- f) the symbol of the grade;
- g) the presence of seals.

EXAMPLE

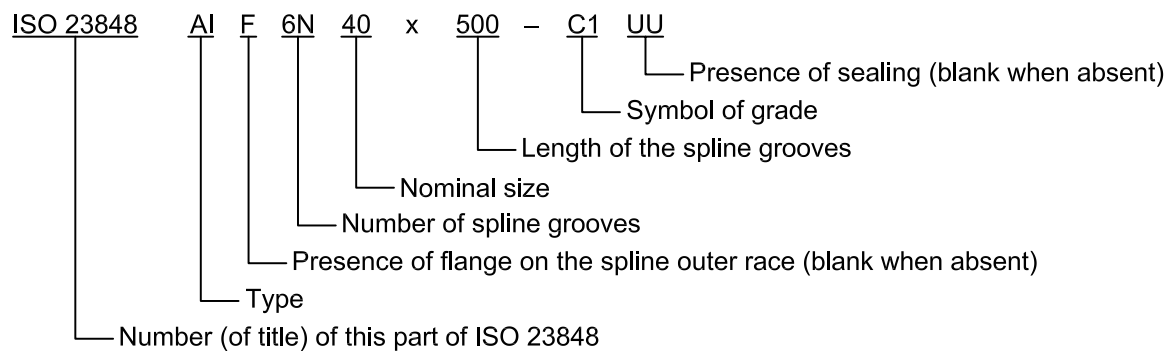

10 Marking

Ball splines shall have an indelible mark with the following information on a conspicuous position on the package.

Furthermore, it is recommended to have a mark indicating the manufacturer's name or abbreviation and the grade of the product on a conspicuous portion on the spline outer race:

- a) a reference to this part of ISO 23848, i.e. ISO 23848-1:2009;
- b) the type and grade, i.e. type A or R and grade C1, C3 or C5;
- c) the number of spline grooves;
- d) the nominal size;
- e) the manufacturer's name or abbreviation.

16

Annex A (normative)

Shapes and dimensions of the spline outer races

A.1 General

This annex specifies the shapes and boundary dimensions of the spline outer races.

A.2 Shapes and dimensions

The shape and dimensions of the spline outer races shall be indicated as given in Figures A.1 and A.2 and Tables A.1 and A.2, respectively.

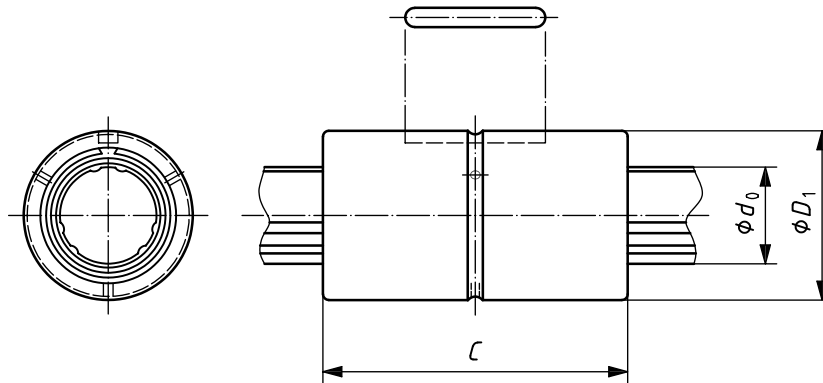
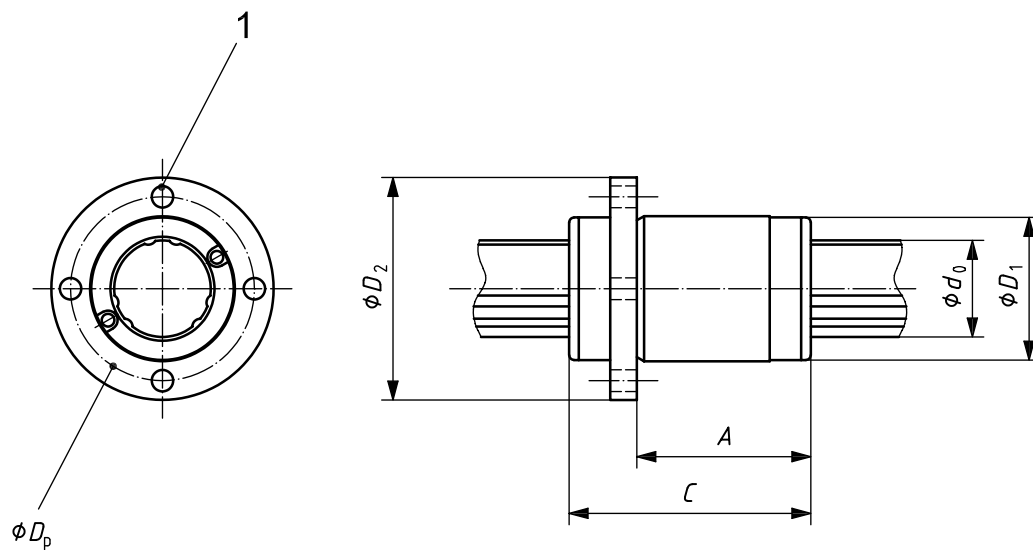
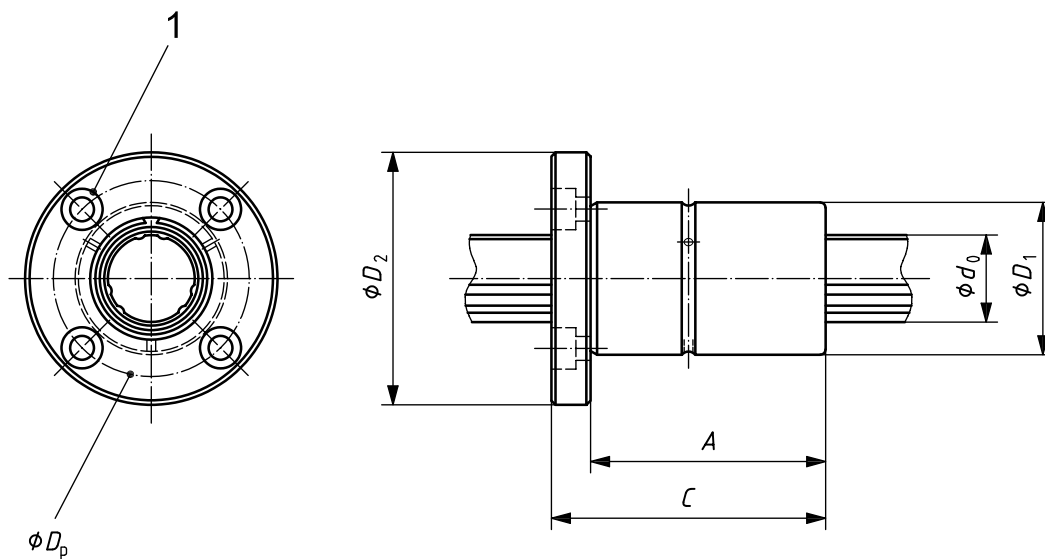

Figure A.1 — Typical shapes of the spline outer race without flange



Key

1 mounting hole

D_p pitch circle diameter

Figure A.2 — Typical shapes of the spline outer races with flange

Table A.1 — Dimensions of the spline outer races without flange

Nominal diameter d_0 mm	Type AI, type AII						Type R		
	Dimension series 1			Dimension series 2			Type R		
	D_1		C^a mm	D_1		C^a mm	D_1		C^a mm
	Basic dimension mm	Tolerance μm		Basic dimension mm	Tolerance μm		Basic dimension mm	Tolerance μm	
6	12	0 -11	21 30	14	0 -11	25	16	0 -11	27
8	15		25 37	16		25	20	0 -13	32
10	19	0 -13	30 47	21	0 -13	33	24		0 -13
12	21		35 54	—	—	—	28	38	
13	—	—	—	24	0 -13	36	—	—	—
15	23	0 -13	40 65	—	—	—	—	—	—
16	—	—	—	31	0 -16	41 50	36	0 -16	57
20	30	0 -16	50 60 71	35		46 63	42		0 -16
25	37		60 70 84	42	60 71	47	69		
30	45	0 -19	70 80 98	47	0 -19	66 80	55	0 -19	82
40	60		90 100	64		100	72		105
50	75	0 -22	100 112	80	0 -22	125	90	0 -22	137
60	90		127 140	—		—	110		158
80	120	0 -25	160 217	—	0 -25	—	140	0 -25	215
100	140		160 175	150		185 248	180	0 -25	265
120	160	—	200	—	—	—	—	—	—

^a The spline outer race length, C , is the overall length including seal dimensions (maximum value).

Table A.2 — Boundary dimensions of the spline outer races with flange

Nominal diameter d_0	Type AI, type AII												Type R											
	Dimension series 1						Dimension series 2																	
	D_1		C^a	A	D_2	Mounting holes D_p	Mounting bolt nominal size b	Number of mounting holes b	Basic dimension	Tolerance	C^a	A	D_2	Mounting holes D_p	Mounting bolt nominal size b	Number of mounting holes b	Basic dimension	Tolerance	C^a	A	D_2	Mounting holes D_p	Mounting bolt nominal size b	Number of mounting holes b
6	12	0_{-11}	21 30	14 23	25	19	M3	4	14	0_{-11}	25 20	19 20	30	22	M3	4	16	0_{-11}	27	19	31	24	M3	4
8	15	0_{-11}	25 37	16 28	28	22	M3	4	16	0_{-11}	25 20	19 20	32	24	M3	4	20	0_{-11}	32	22	40	30	M4	4
10	19	0_{-13}	30 47	20 37	36	28	M4	4	21	0_{-13}	33 27	25 27	42	32	M4	4	24	0_{-13}	36	25	44	34	M4	4
12	21	0_{-13}	35 54	25 44	38	30	M4	4	—	—	—	—	—	—	—	28	28	—	38	27	48	38	M4	4
13	—	—	—	—	—	—	—	—	24	0_{-13}	36 29	28 29	45	34	M4	4	—	—	—	—	—	—	—	—
15	23	0_{-13}	40 65	30 54	43	32	M4	4	—	—	—	—	—	—	—	—	—	—	—	—	—	—	—	—

^a The spline outer race length, C_1 is the overall length including the seal dimensions (maximum value).

^b These values are for information only (not normative).

Table A.2 — (continued)

Nominal diameter d_0	Type AI, type AII																											
	Dimension series 1							Dimension series 2																				
	D_1		C^a	A	D_2	Mounting holes D_p	Mounting bolt nominal size ^b	Number of mounting holes ^b	Basic dimension	Tolerance	C^a	A	D_2	Mounting holes D_p	Mounting bolt nominal size ^b	Number of mounting holes ^b												
16	mm	—	mm	—	mm	mm	mm	mm	µm	mm	mm	mm	mm	mm	mm	mm												
																	41	33	40	48	57	43	60	48	55	48		
20	mm	—	mm	—	mm	mm	mm	mm	µm	mm	mm	mm	mm	mm	mm	mm												
																	50	43	52	60	58	44	66	54	58	44		
																	60	36	46	60	63	54	68	46	63	54	68	46
																	71	31	46	60	63	54	68	46	63	54	68	46
25	mm	37	mm	—	mm	mm	mm	mm	µm	mm	mm	mm	mm	mm	mm	mm												
																	60	49	60	68	69	53.5	72	60	69	53.5	72	60
																	70	43	60	68	71	62	72	54	71	62	72	54
																	84	30	47	60	84	67	68	54	84	67	68	54

a The spline outer race length, C , is the overall length including the seal dimensions (maximum value).

b These values are for information only (not normative).

Table A.2 — (continued)

Nominal diameter d_0	Type A1, type A11										Type R													
	Dimension series 1					Dimension series 2					Type R													
	D_1		C^a	A	D_2	Mounting holes D_p	Mounting bolt nominal size b	Number of mounting holes b	Basic dimension	Tolerance	C^a	A	D_2	Mounting holes D_p	Mounting bolt nominal size b	Number of mounting holes b								
30	45	0_{-16}	70	49	70	54	M6	4	47	0_{-16}	66	70	77	60	M6	4	55	0_{-19}	82	64	88	72	M6	4
			80	80																				
			98	80																				
			90	80																				
40	60	0_{-19}	90	76	90	70	M8	4	64	0_{-19}	100	86	100	82	M8	4	72	0_{-19}	105	82,5	112	92	M8	4
			100	86																				
			90	86																				
			73,4	86																				
50	70	0_{-19}	100	84	102	86	M10	4	80	0_{-19}	125	109	124	102	M10	4	90	0_{-22}	137	106,5	134	112	M10	4
			112	86																				
			100	86																				
			75	86																				
60	85	0_{-22}	127	109	124	102	M10	4	—	—	—	—	—	—	—	110	0_{-25}	158	127	154	132	M10	4	
			90	107																				
			—	—																				
			135	162																				
80	135	0_{-25}	160	135	162	162	M17	4	—	—	—	—	—	—	—	140	0_{-25}	215	173,5	184	162	M12	4	
			—	—																				
			—	—																				
			—	—																				
100	135	0_{-25}	160	135	162	162	M17	4	—	—	—	—	—	—	180	0_{-25}	265	213,5	230	206	M14	4		
			—	—																				
			—	—																				
			—	—																				

a The spline outer race length, C , is the overall length including the seal dimensions (maximum value).

b These values are for information only (not normative).

1
2
3
4
5
6
7
8
9
10
11
12
13
14
15
16
17
18
19
20
21
22
23
24
25
26
27
28
29
30
31
32
33
34
35
36
37
38
39
40
41
42
43
44
45
46
47
48
49
50
51
52
53
54
55
56
57
58
59
60
61
62
63
64
65
66
67
68
69
70
71
72
73
74
75
76
77
78
79
80
81
82
83
84
85
86
87
88
89
90
91
92
93
94
95
96
97
98
99
100

..

ICS 25.060.99

Price based on 22 pages