

INTERNATIONAL  
STANDARD

ISO  
23748

First edition  
2016-10-01

---

---

**Aerospace series — O-ring grooves —  
Dimensions**

*Série aérospatiale — Gorges pour joints toriques — Dimensions*



Reference number  
ISO 23748:2016(E)

© ISO 2016



**COPYRIGHT PROTECTED DOCUMENT**

© ISO 2016, Published in Switzerland

All rights reserved. Unless otherwise specified, no part of this publication may be reproduced or utilized otherwise in any form or by any means, electronic or mechanical, including photocopying, or posting on the internet or an intranet, without prior written permission. Permission can be requested from either ISO at the address below or ISO's member body in the country of the requester.

ISO copyright office  
Ch. de Blandonnet 8 • CP 401  
CH-1214 Vernier, Geneva, Switzerland  
Tel. +41 22 749 01 11  
Fax +41 22 749 09 47  
copyright@iso.org  
www.iso.org

# Contents

Page

<b>Foreword</b> .....	<b>iv</b>
<b>1 Scope</b> .....	<b>1</b>
<b>2 Normative references</b> .....	<b>1</b>
<b>3 Symbols</b> .....	<b>1</b>
<b>4 Required characteristics</b> .....	<b>2</b>
4.1 Configuration — Dimensions — Tolerances.....	2
4.1.1 General.....	2
4.1.2 Radial sealing — Rod housing: Configuration code A.....	2
4.1.3 Radial sealing — Bore housing: Configuration code B.....	9
4.1.4 Axial sealing for internal pressure: Configuration code C.....	16
4.1.5 Axial sealing for external pressure: Configuration code D.....	22
<b>5 Designation</b> .....	<b>28</b>
<b>6 Drawing presentation</b> .....	<b>28</b>
6.1 General.....	28
6.2 Configuration code A.....	28
6.3 Configuration code B.....	29
6.4 Configuration code C.....	29
6.5 Configuration code D.....	29
<b>Bibliography</b> .....	<b>30</b>

## Foreword

ISO (the International Organization for Standardization) is a worldwide federation of national standards bodies (ISO member bodies). The work of preparing International Standards is normally carried out through ISO technical committees. Each member body interested in a subject for which a technical committee has been established has the right to be represented on that committee. International organizations, governmental and non-governmental, in liaison with ISO, also take part in the work. ISO collaborates closely with the International Electrotechnical Commission (IEC) on all matters of electrotechnical standardization.

The procedures used to develop this document and those intended for its further maintenance are described in the ISO/IEC Directives, Part 1. In particular the different approval criteria needed for the different types of ISO documents should be noted. This document was drafted in accordance with the editorial rules of the ISO/IEC Directives, Part 2 (see [www.iso.org/directives](http://www.iso.org/directives)).

Attention is drawn to the possibility that some of the elements of this document may be the subject of patent rights. ISO shall not be held responsible for identifying any or all such patent rights. Details of any patent rights identified during the development of the document will be in the Introduction and/or on the ISO list of patent declarations received (see [www.iso.org/patents](http://www.iso.org/patents)).

Any trade name used in this document is information given for the convenience of users and does not constitute an endorsement.

For an explanation on the meaning of ISO specific terms and expressions related to conformity assessment, as well as information about ISO's adherence to the World Trade Organization (WTO) principles in the Technical Barriers to Trade (TBT) see the following URL: [www.iso.org/iso/foreword.html](http://www.iso.org/iso/foreword.html).

ISO 23748 was prepared by ACE/12/1 as EN 3748:2001 and was adopted (without modification other than those stipulated below) by Technical Committee ISO/TC 20, *Aircraft and space vehicles*, Subcommittee SC 10, *Aerospace fluid systems and components*.

The following are the modifications made in this International Standard:

- reference to ISO 3601-1 size codes in tables;
- correction in [Table 13](#) of value 90,27 to 91,27;
- addition of “static applications” in the title and scope;
- “according to European Standards” was removed in the scope;
- any reference to European Standards were removed.

# Aerospace series — O-ring grooves — Dimensions

## 1 Scope

This International Standard specifies the dimensions of grooves for use with O-rings for aerospace in static sealing applications:

- radial sealing: rod or bore mounted O-rings;
- axial sealing: internal or external pressure source.

## 2 Normative references

The following documents are referred to in the text in such a way that some or all of their content constitutes requirements of this document. For dated references, only the edition cited applies. For undated references, the latest edition of the referenced document (including any amendments) applies.

There are no normative references in this document.

## 3 Symbols

$b$	O-ring groove width
$d_1$	O-ring inside diameter
$d_2$	O-ring section diameter
$d_3$	O-ring groove diameter, rod mounted
$d_4$	bore diameter, rod mounted
$d_5$	rod outside diameter bore mounted
$d_6$	O-ring groove diameter bore mounted
$d_7$	O-ring groove outside diameter, internal pressure
$d_8$	O-ring groove inside diameter, external pressure
$d_9$	rod outside diameter, rod mounted
$d_{10}$	bore diameter, bore mounted
$h$	groove height
$R$	edge radius on groove
$r_1$	corner radius on groove
$t$	housing depth
$Z$	lead-in chamfer length

#### 4 Required characteristics

##### 4.1 Configuration — Dimensions — Tolerances

###### 4.1.1 General

Only recommended sizes are given in the tables.

Dimensions and tolerances are in millimetres. Surface roughness values are in micrometres.

###### 4.1.2 Radial sealing — Rod housing: Configuration code A

###### 4.1.2.1 General

This configuration corresponds to radial grooves in static applications, rod mounted. See [Figure 1](#) and [Tables 1](#) to [7](#).

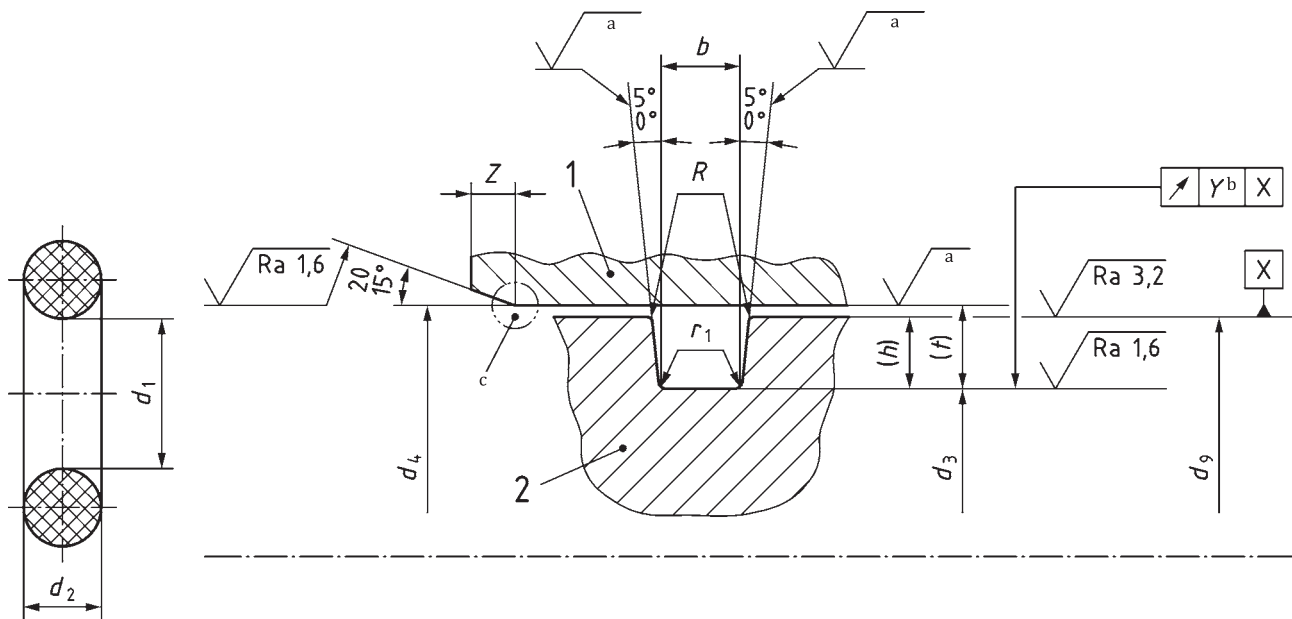

#### Key

- 1 bore
- 2 rod
- a See [Table 1](#).
- b Groove diameter  $d_3 \leq 50$ : maximum run-out tolerance  $Y = 0,025$ .  
Groove diameter  $d_3 > 50$ : maximum run-out tolerance  $Y = 0,05$ .
- c No burrs permitted in this area.

Figure 1

Table 1

Surface		Roughness							
		$R_a$				$R_{max.}$			
		continuous pressure		with pressure variation		continuous pressure		with pressure variation	
		≤5 MPa	>5 MPa	≤5MPa	>5 MPa	≤5 MPa	>5 MPa	≤5 MPa	>5 MPa
Groove	Side surfaces	3,2	1,6	1,6	1,6	12,5	6,3	6,3	6,3
	Inside diameter	1,6				6,3			
Homologous surface					0,8				3,2

Table 2

$d_2$ nom.	$b$		$Z$ min.	$r_1$		$R$	
	max.	min.		max.	min.	max.	min.
1,80	2,65	2,40	1,1	0,4	0,2	0,3	0,1
2,65	3,85	3,60	1,5				
3,55	5,05	4,80	1,8	0,8	0,4		
5,30	7,35	7,10	2,7				
7,00	9,45	9,20	3,6	1,2	0,8		

4.1.2.2 Section diameter  $d_2 = 1,80$ 

Table 3

Code <sup>a</sup>	$d_1$	$d_3$	$d_4$	$d_9$
	nom.	0 -0,04	+0,06 0	f7 <sup>b</sup>
A0040	4,00	4,24	7,00	7,00
A0050	5,00	5,27	8,03	8,03
A0060	6,00	6,30	9,06	9,06
A0069	6,90	7,24	10,00	10,00
A0087	8,75	9,12	11,88	11,88
A0106	10,60	11,02	13,78	13,78
A0125	12,50	12,97	15,73	15,73
A0140	14,00	14,54	17,30	17,30
A0160	16,00	16,64	19,40	19,40
A0180	18,00	18,64	21,40	21,40
A0212	21,20	21,94	24,70	24,70
A0236	23,60	24,44	27,20	27,20
A0280	28,00	28,94	31,70	31,70
A0315	31,50	32,54	35,30	35,30
A0355	35,50	36,64	39,40	39,40
A0365	36,50	37,64	40,40	40,40
A0375	37,50	38,64	41,40	41,40
A0387	38,70	39,84	42,60	42,60
A0400	40,00	41,24	44,00	44,00
<sup>a</sup> Size code corresponding to the codification of O-rings according to ISO 3601-1.				
<sup>b</sup> See ISO 286-2.				



4.1.2.3 Section diameter  $d_2 = 2,65$ 

Table 4

Code <sup>a</sup>	$d_1$	$d_3$	$d_4$	$d_9$
	nom.	0 -0,05	+0,07 0	f7 <sup>b</sup>
B0053	5,30	5,58	9,72	9,72
B0069	6,90	7,25	11,39	11,39
B0095	9,50	9,90	14,04	14,04
B0112	11,20	11,66	15,80	15,80
B0132	13,20	13,76	17,90	17,90
B0150	15,00	15,56	19,70	19,70
B0170	17,00	17,66	21,80	21,80
B0200	20,00	20,66	24,80	24,80
B0224	22,40	23,16	27,30	27,30
B0265	26,50	27,36	31,50	31,50
B0300	30,00	30,96	35,10	35,10
B0345	34,50	35,56	39,70	39,70
B0387	38,70	39,86	44,00	44,00
B0437	43,70	45,06	49,20	49,20
B0500	50,00	51,46	55,60	55,60
B0560	56,00	57,66	61,80	61,80
B0600	60,00	61,76	65,90	65,90
B0650	65,00	66,86	71,00	71,00
B0710	71,00	73,06	77,20	77,20
B0750	75,00	77,16	81,30	81,30
B0800	80,00	82,26	86,40	86,40
<sup>a</sup> Size code corresponding to the codification of O-rings according to ISO 3601-1.				
<sup>b</sup> See ISO 286-2.				

4.1.2.4 Section diameter  $d_2 = 3,55$ 

Table 5

Code <sup>a</sup>	$d_1$	$d_3$	$d_4$	$d_9$
	nom.	0 -0,06	+0,08 0	f7 <sup>b</sup>
C0250	25,00	25,82	31,30	31,30
C0300	30,00	31,02	36,50	36,50
C0355	35,50	36,62	42,10	42,10
C0425	42,50	43,82	49,30	49,30
C0487	48,70	50,12	55,60	55,60
C0545	54,50	56,12	61,60	61,60
C0615	61,50	63,32	68,80	68,80
C0710	71,00	73,02	78,50	78,50
C0800	80,00	82,32	87,80	87,80
C0900	90,00	92,52	98,00	98,00
C1000	100,00	102,82	108,30	108,30
C1120	112,00	115,12	120,60	120,60
C1150	115,00	118,22	123,70	123,70
C1220	122,00	125,32	130,80	130,80
C1320	132,00	135,62	141,10	141,10
C1400	140,00	143,82	149,30	149,30
C1500	150,00	154,12	159,60	159,60
C1600	160,00	164,32	169,80	169,80
C1700	170,00	174,62	180,10	180,10
C1800	180,00	189,92	195,40	195,40
C1900	190,00	195,12	200,60	200,60
C2000	200,00	205,32	210,80	210,80
C2120	212,00	217,62	223,10	223,10
C2240	224,00	229,92	235,40	235,40
C2360	236,00	242,32	247,80	247,80
C2500	250,00	256,62	262,10	262,10
<sup>a</sup> Size code corresponding to the codification of O-rings according to ISO 3601-1.				
<sup>b</sup> See ISO 286-2.				

4.1.2.5 Section diameter  $d_2 = 5,30$ 

Table 6

Code <sup>a</sup>	$d_1$	$d_3$	$d_4$	$d_9$
	nom.	0 -0,07	+0,09 0	f7 <sup>b</sup>
D0600	60,00	61,82	70,20	70,20
D0710	71,00	73,02	81,40	81,40
D0800	80,00	82,32	90,70	90,70
D0900	90,00	92,52	100,90	100,90
D1090	109,00	112,02	120,40	120,40
D1120	112,00	115,12	123,50	123,50
D1180	118,00	121,22	129,60	129,60
D1280	128,00	131,52	139,90	139,90
D1360	136,00	139,72	148,10	148,10
D1450	145,00	148,92	157,30	157,30
D1550	155,00	159,22	167,60	167,60
D1650	165,00	169,42	177,80	177,80
D1750	175,00	179,72	188,10	188,10
D1850	185,00	190,02	198,40	198,40
D1950	195,00	200,22	208,60	208,60
D2000	200,00	205,32	213,70	213,70

<sup>a</sup> Size code corresponding to the codification of O-rings according to ISO 3601-1.

<sup>b</sup> See ISO 286-2.

4.1.2.6 Section diameter  $d_2 = 7,00$

Table 7

Code <sup>a</sup>	$d_1$	$d_3$	$d_4$	$d_9$
	nom.	0 -0,09	+0,11 0	f7 <sup>b</sup>
E1090	109,00	112,06	123,40	123,40
E1150	115,00	118,26	129,60	129,60
E1250	125,00	128,46	139,80	139,80
E1360	136,00	139,76	151,10	151,10
E1450	145,00	148,96	160,30	160,30
E1550	155,00	159,26	170,60	170,60
E1650	165,00	169,46	180,80	180,80
E1750	175,00	179,76	191,10	191,10
E1850	185,00	189,96	201,30	201,30
E1900	190,00	195,16	206,50	206,50
E2000	200,00	205,36	216,70	216,70
E2120	212,00	217,66	229,00	229,00
E2240	224,00	229,86	241,20	241,20
E2300	230,00	236,16	247,50	247,50
E2430	243,00	249,46	260,80	260,80
E2500	250,00	256,66	268,00	268,00
E2580	258,00	264,86	276,20	276,20
E2720	272,00	279,26	290,60	290,60
E2800	280,00	287,46	298,80	298,80
E2900	290,00	297,66	309,00	309,00
E3000	300,00	307,96	319,30	319,30
E3150	315,00	323,36	334,70	334,70
E3250	325,00	333,56	344,90	344,90
E3350	335,00	343,86	355,20	355,20
E3450	345,00	354,06	365,40	365,40
E3550	355,00	364,36	375,70	375,70
E3650	365,00	374,56	385,90	385,90
E3750	375,00	384,86	396,20	396,20
E3870	387,00	397,16	408,50	408,50
E4000	400,00	410,46	421,80	421,80
<sup>a</sup> Size code corresponding to the codification of O-rings according to ISO 3601-1.				
<sup>b</sup> See ISO 286-2.				

4.1.3 Radial sealing — Bore housing: Configuration code B

4.1.3.1 General

This configuration (not recommended) corresponds to radial grooves in static applications, bore mounted. See [Figure 2](#) and [Tables 8](#) to [14](#).

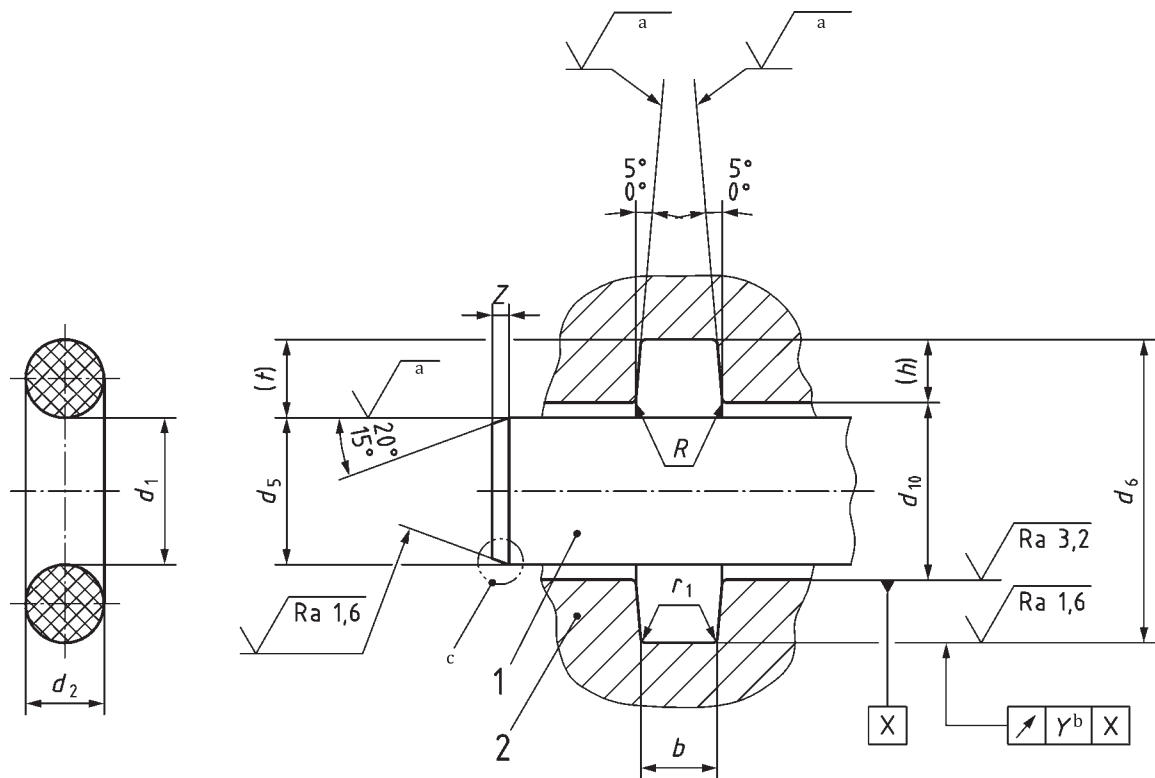

Key

- 1 rod
- 2 bore
- a See [Table 8](#).
- b Groove diameter  $d_6 \leq 50$ : maximum run-out tolerance  $Y = 0,025$ .  
Groove diameter  $d_6 > 50$ : maximum run-out tolerance  $Y = 0,05$ .
- c No burrs permitted in this area.

Figure 2

Table 8

Surface		Roughness							
		$R_a$				$R_{max.}$			
		continuous pressure		with pressure variation		continuous pressure		with pressure variation	
		≤5 MPa	>5 MPa	≤5 MPa	>5 MPa	≤5 MPa	>5 MPa	≤5 MPa	>5 MPa
Groove	Side surfaces	3,2	1,6	1,6	1,6	12,5	6,3	6,3	6,3
	Inside diameter	1,6				6,3			
Homologous surface					0,8				3,2

Table 9

$d_2$ nom.	$b$		$Z$ min.	$r_1$		$R$	
	max.	min.		max.	min.	max.	min.
1,80	2,65	2,40	1,1	0,4	0,2	0,3	0,1
2,65	3,85	3,60	1,5				
3,55	5,05	4,80	1,8	0,8	0,4		
5,30	7,35	7,10	2,7				
7,00	9,45	9,20	3,6	1,2	0,8		

4.1.3.2 Section diameter  $d_2 = 1,80$ 

Table 10

Code <sup>a</sup>	$d_1$	$d_5$	$d_6$	$d_{10}$
	nom.	0 -0,04	+0,06 0	H8 <sup>b</sup>
A0040	4,00	4,29	7,13	4,37
A0048	4,87	5,15	7,99	5,23
A0056	5,60	5,84	8,68	5,92
A0067	6,70	6,86	9,70	6,94
A0080	8,00	8,16	11,00	8,24
A0087	8,75	8,86	11,70	8,94
A0100	10,00	10,06	12,90	10,14
A0118	11,80	11,86	14,70	11,94
A0140	14,00	13,96	16,80	14,04
A0160	16,00	15,96	18,80	16,04
A0180	18,00	17,86	20,70	17,94
A0200	20,00	19,86	22,70	19,94
A0224	22,40	22,16	25,00	22,24
A0250	25,00	24,66	27,50	24,74
A0280	28,00	27,66	30,50	27,74
A0325	32,50	32,06	34,90	32,14
A0365	36,50	36,06	38,90	36,14
A0400	40,00	39,36	42,20	39,44

<sup>a</sup> Size code corresponding to the codification of O-rings according to ISO 3601-1.

<sup>b</sup> See ISO 286-2.

4.1.3.3 Section diameter  $d_2 = 2,65$ 

Table 11

Code <sup>a</sup>	$d_1$	$d_5$	$d_6$	$d_{10}$
	nom.	0 -0,05	+0,07 0	H8 <sup>b</sup>
B0045	4,50	5,07	9,37	5,23
B0060	6,00	6,48	10,78	6,64
B0069	6,90	7,33	11,63	7,49
B0080	8,00	8,42	12,72	8,58
B0090	9,00	9,42	13,72	9,58
B0100	10,00	10,32	14,62	10,48
B0118	11,80	12,12	16,42	12,28
B0140	14,00	14,22	18,52	14,38
B0150	15,00	15,22	19,52	15,38
B0180	18,00	18,12	22,42	18,28
B0200	20,00	20,12	24,42	20,28
B0224	22,40	22,42	26,72	22,58
B0250	25,00	24,92	29,22	25,08
B0280	28,00	27,92	32,22	28,08
B0325	32,50	32,12	36,42	32,28
B0365	36,50	36,12	40,42	36,28
B0400	40,00	39,52	43,82	39,68
B0450	45,00	44,42	48,72	44,58
B0500	50,00	49,32	53,62	49,48
B0560	56,00	55,12	59,42	55,28

<sup>a</sup> Size code corresponding to the codification of O-rings according to ISO 3601-1.

<sup>b</sup> See ISO 286-2.



4.1.3.4 Section diameter  $d_2 = 3,55$ 

Table 12

Code <sup>a</sup>	$d_1$	$d_5$	$d_6$	$d_{10}$
	nom.	0 -0,06	+0,08 0	H8 <sup>b</sup>
C0250	25,00	25,29	30,99	25,51
C0300	30,00	30,19	35,89	30,41
C0355	35,50	35,49	41,19	35,71
C0400	40,00	39,89	45,59	40,11
C0450	45,00	44,79	50,49	45,01
C0500	50,00	49,69	55,39	49,91
C0560	56,00	55,49	61,19	55,71
C0630	63,00	62,29	67,99	62,51
C0710	71,00	70,19	75,89	70,41
C0800	80,00	78,89	84,59	79,11
C0900	90,00	88,69	94,39	88,91
C1000	100,00	98,29	103,99	98,51
C1120	112,00	109,99	115,69	110,21
C1250	125,00	122,69	128,39	122,91
<sup>a</sup> Size code corresponding to the codification of O-rings according to ISO 3601-1.				
<sup>b</sup> See ISO 286-2.				

4.1.3.5 Section diameter  $d_2 = 5,30$ 

Table 13

Code <sup>a</sup>	$d_1$	$d_5$	$d_6$	$d_{10}$
	nom.	0 -0,07	+0,09 0	H8 <sup>b</sup>
D0600	60,00	61,33	70,05	61,67
D0710	71,00	72,13	80,85	72,47
D0800	80,00	81,03	89,75	81,37
D0900	90,00	90,93	99,65	91,27
D1000	100,00	100,73	109,45	101,07
D1090	109,00	109,63	118,35	109,97
D1120	112,00	112,53	121,25	112,87
D1150	115,00	115,53	124,25	115,87
D1180	118,00	118,53	127,25	118,87
D1220	122,00	122,43	131,15	122,77
D1250	125,00	125,43	134,15	125,77
D1280	128,00	128,33	137,05	128,67
D1320	132,00	132,33	141,05	132,67
D1400	140,00	140,23	148,95	140,57
D1600	160,00	159,93	168,65	160,27
D1800	180,00	179,63	188,35	179,97
D2000	200,00	199,33	208,05	199,67

<sup>a</sup> Size code corresponding to the codification of O-rings according to ISO 3601-1.

<sup>b</sup> See ISO 286-2.

4.1.3.6 Section diameter  $d_2 = 7,00$ 

Table 14

Code <sup>a</sup>	$d_1$	$d_5$	$d_6$	$d_{10}$
	nom.	0 -0,09	+0,11 0	H8 <sup>b</sup>
E1090	109,00	109,98	121,76	110,42
E1250	125,00	125,78	137,56	126,22
E1400	140,00	140,58	152,36	141,02
E1600	160,00	160,28	172,06	160,72
E1800	180,00	179,98	191,76	180,42
E2000	200,00	199,68	211,46	200,12
E2240	224,00	223,48	235,26	223,92
E2500	250,00	248,98	260,76	249,42
E2800	280,00	278,48	290,26	278,92
E3250	325,00	322,98	334,76	323,42
E3650	365,00	362,48	374,26	362,92
E4000	400,00	396,78	408,56	397,22

<sup>a</sup> Size code corresponding to the codification of O-rings according to ISO 3601-1.

<sup>b</sup> See ISO 286-2.

4.1.4 Axial sealing for internal pressure: Configuration code C

4.1.4.1 General

This configuration corresponds to axial grooves in static applications with internal pressure source. See [Figure 3](#) and [Tables 15](#) to [21](#).

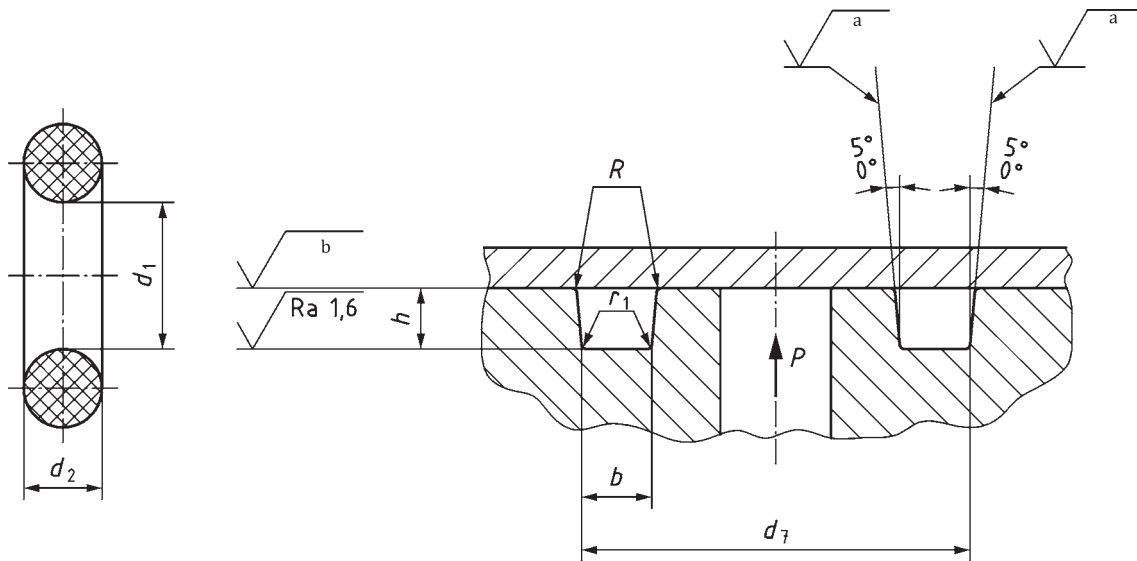

Key

- a See [Table 15](#).
- b See [Table 15](#) for the homologous pressed on the seal.

Figure 3

Table 15

Surface		Roughness							
		$R_a$				$R$ max.			
		continuous pressure		with pressure variation		continuous pressure		with pressure variation	
		$\leq 5\text{ MPa}$	$> 5\text{ MPa}$	$\leq 5\text{ MPa}$	$> 5\text{ MPa}$	$\leq 5\text{ MPa}$	$> 5\text{ MPa}$	$\leq 5\text{ MPa}$	$> 5\text{ MPa}$
Groove	Side surfaces	3,2	1,6	1,6	1,6	12,5	6,3	6,3	6,3
	Inside diameter	1,6				6,3			
Homologous surface					0,8				3,2

Table 16

$d_2$ nom.	$b$		$h$		$r_1$		$R$	
	max.	min.	max.	min.	max.	min.	max.	min.
1,80	2,85	2,60	1,38	1,28	0,4	0,2	0,3	0,1
2,65	4,05	3,80	2,07	1,97				
3,55	5,25	5,00	2,85	2,75	0,8	0,4		
5,30	7,55	7,30	4,34	4,24				
7,00	9,65	9,40	5,82	5,72	1,2	0,8		

4.1.4.2 Section diameter  $d_2 = 1,80$ 

Table 17

Code <sup>a</sup>	$d_1$	$d_7$ H11 <sup>b</sup>	Code <sup>a</sup>	$d_1$	$d_7$ H11 <sup>b</sup>
	nom.			nom.	
A0056	5,60	9,2	A0200	20,00	23,60
A0060	6,00	9,6	A0212	21,20	24,80
A0063	6,30	9,9	A0224	22,40	26,00
A0067	6,70	10,3	A0236	23,60	27,20
A0069	6,90	10,5	A0250	25,00	28,60
A0071	7,10	10,7	A0258	25,80	29,40
A0075	7,50	11,10	A0265	26,50	30,10
A0080	8,00	11,60	A0280	28,00	31,60
A0085	8,50	12,10	A0300	30,00	33,60
A0087	8,75	12,35	A0315	31,50	35,10
A0090	9,00	12,60	A0325	32,50	36,10
A0095	9,50	13,10	A0335	33,50	37,10
A0100	10,00	13,60	A0345	34,50	38,10
A0106	10,60	14,20	A0355	35,50	39,10
A0112	11,20	14,80	A0365	36,50	40,10
A0118	11,80	15,40	A0375	37,50	41,10
A0125	12,50	16,10	A0387	38,70	42,30
A0132	13,20	16,80	A0400	40,00	43,60
A0140	14,00	17,60	A0412	41,20	44,80
A0150	15,00	18,60	A0425	42,50	46,10
A0160	16,00	19,60	A0437	43,70	47,30
A0170	17,00	20,60	A0450	45,00	48,60
A0180	18,00	21,60	A0475	47,50	51,10
A0190	19,00	22,60	A0500	50,00	53,60

<sup>a</sup> Size code corresponding to the codification of O-rings according to ISO 3601-1.  
<sup>b</sup> See ISO 286-2.

4.1.4.3 Section diameter  $d_2 = 2,65$

**Table 18**

Code <sup>a</sup>	$d_1$		$d_7$ H11 <sup>b</sup>	Code <sup>a</sup>	$d_1$		$d_7$ H11 <sup>b</sup>
	nom.				nom.		
B0250	25,00		30,30	B0500	50,00		55,30
B0258	25,80		31,10	B0515	51,50		56,80
B0265	26,50		31,80	B0530	53,00		58,30
B0280	28,00		33,30	B0545	54,50		59,80
B0300	30,00		35,30	B0560	56,00		61,30
B0315	31,50		36,80	B0580	58,00		63,30
B0325	32,50		37,80	B0600	60,00		65,30
B0335	33,50		38,80	B0615	61,50		66,80
B0345	34,50		39,80	B0630	63,00		68,30
B0355	35,50		40,80	B0650	65,00		70,30
B0365	36,50		41,80	B0670	67,00		72,30
B0375	37,50		42,80	B0690	69,00		74,30
B0387	38,70		44,00	B0710	71,00		76,30
B0400	40,00		45,30	B0730	73,00		78,30
B0412	41,20		46,50	B0750	75,00		80,30
B0425	42,50		47,80	B0800	80,00		85,30
B0437	43,70		49,00	B0850	85,00		90,30
B0450	45,00		50,30	B0900	90,00		95,30
B0462	46,20		51,50	B0950	95,00		100,30
B0475	47,50		52,80	B1000	100,00		105,30
B0487	48,70		54,00				
<sup>a</sup> Size code corresponding to the codification of O-rings according to ISO 3601-1. <sup>b</sup> See ISO 286-2.							

4.1.4.4 Section diameter  $d_2 = 3,55$ 

Table 19

Code <sup>a</sup>	$d_1$		$d_7$ H11 <sup>b</sup>	Code <sup>a</sup>	$d_1$		$d_7$ H11 <sup>b</sup>
	nom.				nom.		
C0800	80,00		87,10	C1360	136,00		143,10
C0850	85,00		92,10	C1400	140,00		147,10
C0900	90,00		97,10	C1450	145,00		152,10
C0950	95,00		102,10	C1500	150,00		157,10
C1000	100,00		107,10	C1550	155,00		162,10
C1030	103,00		110,10	C1600	160,00		167,10
C1060	106,00		113,10	C1650	165,00		172,10
C1090	109,00		116,10	C1700	170,00		177,10
C1120	112,00		119,10	C1750	175,00		182,10
C1150	115,00		122,10	C1800	180,00		187,10
C1180	118,00		125,10	C1850	185,00		192,10
C1220	122,00		129,10	C1900	190,00		197,10
C1250	125,00		132,10	C1950	195,00		202,10
C1280	128,00		135,10	C2000	200,00		207,10
C1320	132,00		139,10				
<sup>a</sup>	Size code corresponding to the codification of O-rings according to ISO 3601-1.						
<sup>b</sup>	See ISO 286-2.						

4.1.4.5 Section diameter  $d_2 = 5,30$

**Table 20**

Code <sup>a</sup>	$d_1$ nom.	$d_7$ H11 <sup>b</sup>	Code <sup>a</sup>	$d_1$ nom.	$d_7$ H11 <sup>b</sup>
D0900	90,00	100,60	D1360	136,00	146,60
D0925	92,50	103,10	D1400	140,00	150,60
D0950	95,00	105,60	D1450	145,00	155,60
D0975	97,50	108,10	D1500	150,00	160,60
D1000	100,00	110,60	D1550	155,00	165,60
D1030	103,00	113,60	D1600	160,00	170,60
D1060	106,00	116,60	D1650	165,00	175,60
D1090	109,00	119,60	D1700	170,00	180,60
D1120	112,00	122,60	D1750	175,00	185,60
D1150	115,00	125,60	D1800	180,00	190,60
D1180	118,00	128,60	D1850	185,00	195,60
D1220	122,00	132,60	D1900	190,00	200,60
D1250	125,00	135,60	D1950	195,00	205,60
D1280	128,00	138,60	D2000	200,00	210,60
D1320	132,00	142,60			
<sup>a</sup> Size code corresponding to the codification of O-rings according to ISO 3601-1. <sup>b</sup> See ISO 286-2.					



4.1.4.6 Section diameter  $d_2 = 7,00$ 

Table 21

Code <sup>a</sup>	$d_1$		$d_7$ H11 <sup>b</sup>	Code <sup>a</sup>	$d_1$		$d_7$ H11 <sup>b</sup>
	nom.				nom.		
E2000	200,00		214,00	E2900	290,00		304,00
E2060	206,00		220,00	E3000	300,00		314,00
E2120	212,00		226,00	E3070	307,00		321,00
E2180	218,00		232,00	E3150	315,00		329,00
E2240	224,00		238,00	E3250	325,00		339,00
E2300	230,00		244,00	E3350	335,00		349,00
E2360	236,00		250,00	E3450	345,00		359,00
E2430	243,00		257,00	E3550	355,00		369,00
E2500	250,00		264,00	E3650	365,00		379,00
E2580	258,00		272,00	E3750	375,00		389,00
E2650	265,00		279,00	E3870	387,00		401,00
E2720	272,00		286,00	E4000	400,00		414,00
E2800	280,00		294,00				
<sup>a</sup> Size code corresponding to the codification of O-rings according to ISO 3601-1. <sup>b</sup> See ISO 286-2.							

4.1.5 Axial sealing for external pressure: Configuration code D

4.1.5.1 General

This configuration corresponds to axial grooves in static applications with external pressure source. See [Figure 4](#) and [Tables 22](#) to [28](#).

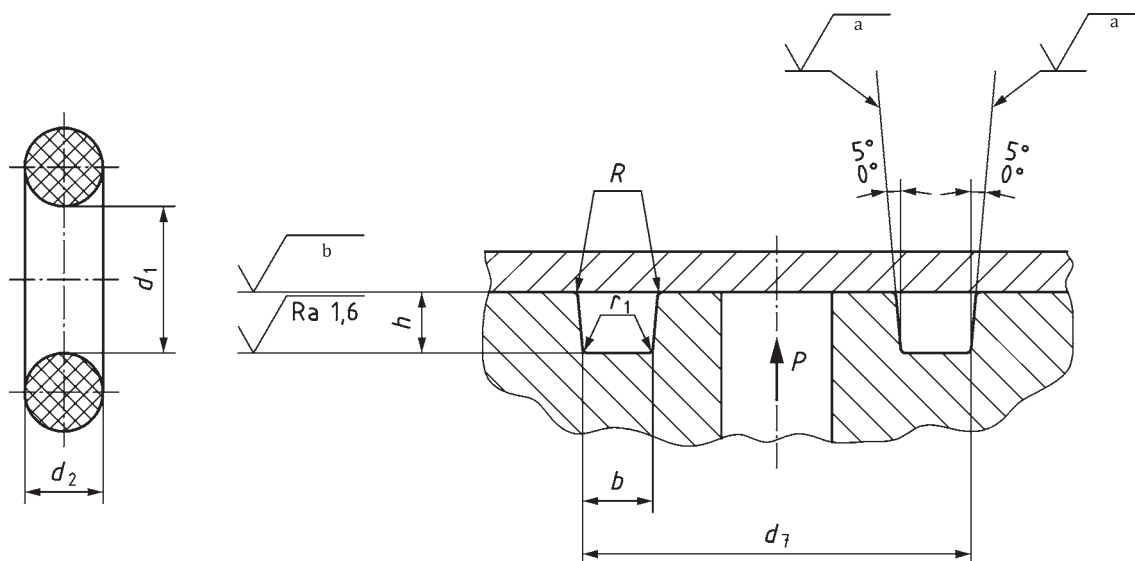

Key

- a See [Table 22](#).
- b See [Table 22](#) for the homologous pressed on the seal.

Figure 4

Table 22

Surface		Roughness							
		$R_a$				$R_{max.}$			
		continuous pressure		with pressure variation		continuous pressure		with pressure variation	
		≤5 MPa	>5 MPa	≤5 MPa	>5 MPa	≤5 MPa	>5 MPa	≤5 MPa	>5 MPa
Groove	Side surfaces	3,2	1,6	1,6	1,6	12,5	6,3	6,3	6,3
	Inside diameter	1,6				6,3			
Homologous surface					0,8				3,2

Table 23

$d_2$ nom.	$b$		$h$		$r_1$		$R$	
	max.	min.	max.	min.	max.	min.	max.	min.
1,80	2,85	2,60	1,38	1,28	0,4	0,2	0,3	0,1
2,65	4,05	3,80	2,07	1,97				
3,55	5,25	5,00	2,85	2,75	0,8	0,4		
5,30	7,55	7,30	4,34	4,24				
7,00	9,65	9,40	5,82	5,72	1,2	0,8		

4.1.5.2 Section diameter  $d_2 = 1,80$

Table 24

$d_1$		$d_8$	$d_1$		$d_8$
Code <sup>a</sup>	nom.	H11 <sup>b</sup>	Code <sup>a</sup>	nom.	h11 <sup>b</sup>
A0056	5,60	5,675	A0200	20,00	20,13
A0060	6,00	6,09	A0212	21,20	21,33
A0063	6,30	6,39	A0224	22,40	22,53
A0067	6,70	6,79	A0236	23,60	23,73
A0069	6,90	6,99	A0250	25,00	25,13
A0071	7,10	7,19	A0258	25,80	25,93
A0075	7,50	7,59	A0265	26,50	26,63
A0080	8,00	8,09	A0280	28,00	28,13
A0085	8,50	8,59	A0300	30,00	30,16
A0087	8,75	8,84	A0315	31,50	31,66
A0090	9,00	9,09	A0325	32,50	32,66
A0095	9,50	9,59	A0335	33,50	33,66
A0100	10,00	10,11	A0345	34,50	34,66
A0106	10,60	10,71	A0355	35,50	35,66
A0112	11,20	11,31	A0365	36,50	36,66
A0118	11,80	11,91	A0375	37,50	37,66
A0125	12,50	12,61	A0387	38,70	38,86
A0132	13,20	13,31	A0400	40,00	40,16
A0140	14,00	14,11	A0412	41,20	41,36
A0150	15,00	15,11	A0425	42,50	42,66
A0160	16,00	16,11	A0437	43,70	43,86
A0170	17,00	17,11	A0450	45,00	45,16
A0180	18,00	18,13	A0475	47,50	47,66
A0190	19,00	19,13	A0500	50,00	50,19
<sup>a</sup> Size code corresponding to the codification of O-rings according to ISO 3601-1. <sup>b</sup> See ISO 286-2.					

4.1.5.3 Section diameter  $d_2 = 2,65$ 

Table 25

Code <sup>a</sup>	$d_1$		$d_8$ H11 <sup>b</sup>	Code <sup>a</sup>	$d_1$		$d_8$ h11 <sup>b</sup>
	nom.				nom.		
B0080	8,00		8,09	B0400	40,00		40,16
B0090	9,00		9,09	B0412	41,20		41,36
B0100	10,00		10,11	B0425	42,50		42,66
B0112	11,20		11,31	B0437	43,70		43,86
B0125	12,50		12,61	B0450	45,00		45,16
B0132	13,20		13,31	B0462	46,20		46,36
B0140	14,00		14,11	B0475	47,50		47,66
B0150	15,00		15,11	B0487	48,70		48,86
B0160	16,00		16,11	B0500	50,00		50,19
B0170	17,00		17,11	B0515	51,50		51,69
B0180	18,00		18,13	B0530	53,00		53,19
B0190	19,00		19,13	B0545	54,50		54,69
B0200	20,00		20,13	B0560	56,00		56,19
B0212	21,20		21,33	B0580	58,00		58,19
B0224	22,40		22,53	B0600	60,00		60,19
B0236	23,60		23,73	B0615	61,50		61,69
B0250	25,00		25,13	B0630	63,00		63,19
B0258	25,80		25,93	B0650	65,00		65,19
B0265	26,50		26,63	B0670	67,00		67,19
B0280	28,00		28,13	B0690	69,00		69,19
B0300	30,00		30,16	B0710	71,00		71,19
B0315	31,50		31,66	B0730	73,00		73,19
B0325	32,50		32,66	B0750	75,00		75,19
B0335	33,50		33,66	B0800	80,00		80,22
B0345	34,50		34,66	B0850	85,00		85,22
B0355	35,50		35,66	B0900	90,00		90,22
B0365	36,50		36,66	B0950	95,00		95,22
B0375	37,50		37,66	B1000	100,00		100,22
B0387	38,70		38,86				
<sup>a</sup> Size code corresponding to the codification of O-rings according to ISO 3601-1.							
<sup>b</sup> See ISO 286-2.							

4.1.5.4 Section diameter  $d_2 = 3,55$

Table 26

Code <sup>a</sup>	$d_1$	$d_8$ H11 <sup>b</sup>	Code <sup>a</sup>	$d_1$	$d_8$ h11 <sup>b</sup>
	nom.			nom.	
C0300	30,00	30,16	C1180	118,00	118,22
C0355	35,50	35,66	C1220	122,00	122,25
C0400	40,00	40,16	C1250	125,00	125,25
C0450	45,00	45,16	C1280	128,00	128,25
C0500	50,00	50,19	C1320	132,00	132,25
C0560	56,00	56,19	C1360	136,00	136,25
C0600	60,00	60,19	C1400	140,00	140,25
C0650	65,00	65,19	C1450	145,00	145,25
C0710	71,00	71,19	C1500	150,00	150,25
C0750	75,00	75,19	C1550	155,00	155,25
C0800	80,00	80,22	C1600	160,00	160,25
C0850	85,00	85,22	C1650	165,00	165,25
C0900	90,00	90,22	C1700	170,00	170,25
C0950	95,00	95,22	C1750	175,00	175,25
C1000	100,00	100,22	C1800	180,00	180,29
C1030	103,00	103,22	C1850	185,00	185,29
C1060	106,00	106,22	C1900	190,00	190,29
C1090	109,00	109,22	C1950	195,00	195,29
C1120	112,00	112,22	C2000	200,00	200,29
C1150	115,00	115,22			
<sup>a</sup> Size code corresponding to the codification of O-rings according to ISO 3601-1.					
<sup>b</sup> See ISO 286-2.					

4.1.5.5 Section diameter  $d_2 = 5,30$ 

Table 27

$d_1$		$d_8$	$d_1$		$d_8$
Code <sup>a</sup>	nom.	H11 <sup>b</sup>	Code <sup>a</sup>	nom.	h11 <sup>b</sup>
D0900	90,00	90,22	D1360	136,00	136,25
D0925	92,50	92,72	D1400	140,00	140,25
D0950	95,00	95,22	D1450	145,00	145,25
D0975	97,50	97,72	D1500	150,00	150,25
D1000	100,00	100,22	D1550	155,00	155,25
D1030	103,00	103,22	D1600	160,00	160,25
D1060	106,00	106,22	D1650	165,00	165,25
D1090	109,00	109,22	D1700	170,00	170,25
D1120	112,00	112,22	D1750	175,00	175,25
D1150	115,00	115,22	D1800	180,00	180,29
D1180	118,00	118,22	D1850	185,00	185,29
D1220	122,00	122,25	D1900	190,00	190,29
D1250	125,00	125,25	D1950	195,00	195,29
D1280	128,00	128,25	D2000	200,00	200,29
D1320	132,00	132,25			
<sup>a</sup> Size code corresponding to the codification of O-rings according to ISO 3601-1.					
<sup>b</sup> See ISO 286-2.					

4.1.5.6 Section diameter  $d_2 = 7,00$ 

Table 28

$d_1$		$d_8$	$d_1$		$d_8$
Code <sup>a</sup>	nom.	H11 <sup>b</sup>	Code <sup>a</sup>	nom.	h11 <sup>b</sup>
E2000	200,00	200,29	E2900	290,00	290,32
E2060	206,00	206,29	E3000	300,00	300,32
E2120	212,00	212,29	E3070	307,00	307,32
E2180	218,00	218,29	E3150	315,00	315,36
E2240	224,00	224,29	E3250	325,00	325,36
E2300	230,00	230,29	E3350	335,00	335,36
E2360	236,00	236,29	E3450	345,00	345,36
E2430	243,00	243,29	E3550	355,00	355,36
E2500	250,00	250,32	E3650	365,00	365,36
E2580	258,00	258,32	E3750	375,00	375,36
E2650	265,00	265,32	E3870	387,00	387,36
E2720	272,00	272,32	E4000	400,00	400,40
E2800	280,00	280,32			
<sup>a</sup> Size code corresponding to the codification of O-rings according to ISO 3601-1.					
<sup>b</sup> See ISO 286-2.					

## 5 Designation

EXAMPLE

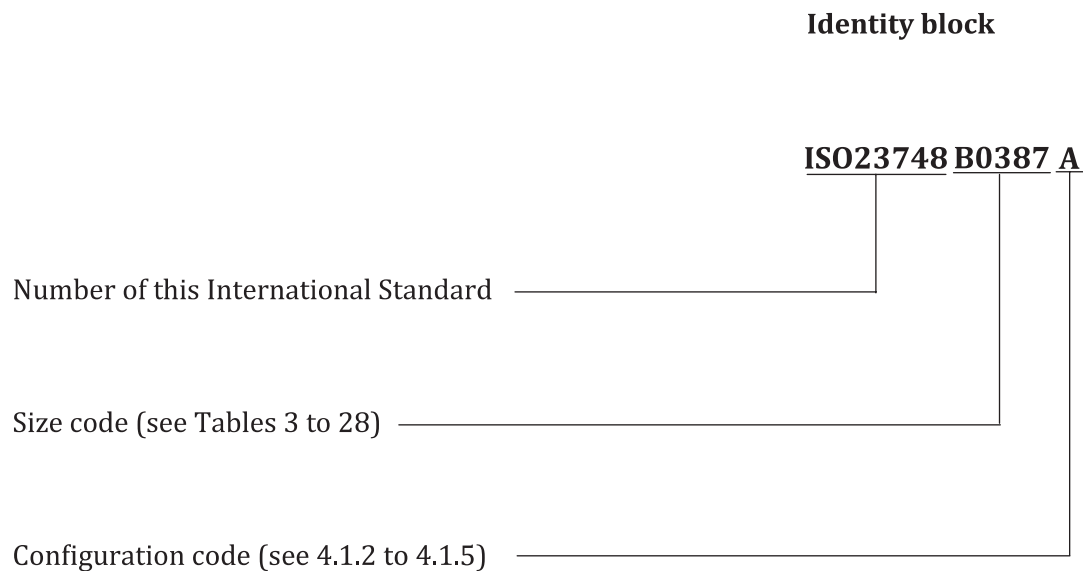

## 6 Drawing presentation

### 6.1 General

The recommended configurations are specified in 6.2 to 6.5. However, indicate all dimensions in conformity with this International Standard is acceptable.

### 6.2 Configuration code A

EXAMPLE See [Figure 5](#).

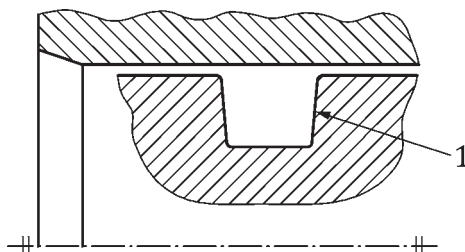

Key

1 ISO23748A0040A

Figure 5



### 6.3 Configuration code B

EXAMPLE See [Figure 6](#).

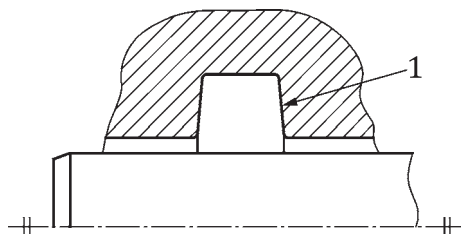

**Key**

1 ISO23748B0100B

**Figure 6**

### 6.4 Configuration code C

EXAMPLE See [Figure 7](#).

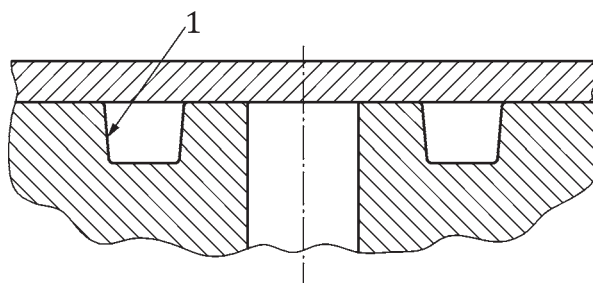

**Key**

1 ISO23748B0400C

**Figure 7**

### 6.5 Configuration code D

EXAMPLE See [Figure 8](#).

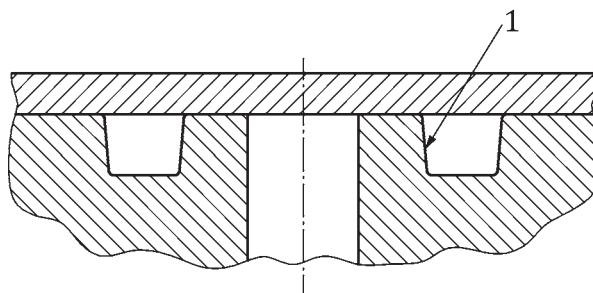

**Key**

1 ISO23748E3650D

**Figure 8**

## Bibliography

- [1] ISO 286-2, Geometrical product specifications (GPS) — ISO code system for tolerances on linear sizes — Part 2: Tables of standard tolerance classes and limit deviations for holes and shafts
- [2] ISO 3601-1, Fluid power systems — O-rings — Part 1: Inside diameters, cross-sections, tolerances and designation codes



**ISO 23748:2016(E)**

---

---

**ICS 49.080; 49.100**

Price based on 30 pages

© ISO 2016 – All rights reserved