

INTERNATIONAL STANDARD

ISO
23599

First edition
2012-03-01

Assistive products for blind and vision- impaired persons — Tactile walking surface indicators

*Produits d'assistance pour personnes aveugles ou visuellement
affaiblies — Indicateurs tactiles de surfaces de marche*



Reference number
ISO 23599:2012(E)

© ISO 2012

ISO 23599:2012(E)



COPYRIGHT PROTECTED DOCUMENT

© ISO 2012

All rights reserved. Unless otherwise specified, no part of this publication may be reproduced or utilized in any form or by any means, electronic or mechanical, including photocopying and microfilm, without permission in writing from either ISO at the address below or ISO's member body in the country of the requester.

ISO copyright office
Case postale 56 • CH-1211 Geneva 20
Tel. + 41 22 749 01 11
Fax + 41 22 749 09 47
E-mail copyright@iso.org
Web www.iso.org

Published in Switzerland

Contents	Page
Foreword	iv
Introduction	v
1 Scope	1
2 Terms and definitions	1
3 General provisions	3
3.1 General principles	3
3.2 Detecting and distinguishing TWSIs	3
4 Requirements and recommendations	4
4.1 Specifications for shape and dimensions of TWSIs	4
4.2 Surrounding or adjacent surfaces	8
4.3 Visual contrast	9
4.4 Materials	10
4.5 Installation	10
Annex A (informative) Luminance contrast	12
Annex B (informative) Examples of installations of TWSIs in specific situations	15
Bibliography	35

ISO 23599:2012(E)

Foreword

ISO (the International Organization for Standardization) is a worldwide federation of national standards bodies (ISO member bodies). The work of preparing International Standards is normally carried out through ISO technical committees. Each member body interested in a subject for which a technical committee has been established has the right to be represented on that committee. International organizations, governmental and non-governmental, in liaison with ISO, also take part in the work. ISO collaborates closely with the International Electrotechnical Commission (IEC) on all matters of electrotechnical standardization.

International Standards are drafted in accordance with the rules given in the ISO/IEC Directives, Part 2.

The main task of technical committees is to prepare International Standards. Draft International Standards adopted by the technical committees are circulated to the member bodies for voting. Publication as an International Standard requires approval by at least 75 % of the member bodies casting a vote.

Attention is drawn to the possibility that some of the elements of this document may be the subject of patent rights. ISO shall not be held responsible for identifying any or all such patent rights.

ISO 23599 was prepared by Technical Committee ISO/TC 173, *Assistive products for persons with disability*.

Introduction

The purpose of this International Standard is to create requirements for tactile walking surface indicators (TWSIs) for blind or vision-impaired persons.

When blind or vision-impaired persons travel alone they might encounter problems and hazards in various situations. In order to obtain information for wayfinding, these pedestrians use information available from the natural and built environment, including tactual, acoustic and visual information. However, environmental information is not always reliable; it is for this reason that TWSIs perceived through use of a long white cane, through the soles of the shoes and through use of residual vision have been developed.

TWSIs were invented in Japan in 1965. They are now used around the world to help blind or vision-impaired persons to travel independently. At present, TWSI patterns and installation methods vary from country to country. This International Standard aims to provide a basis for a common approach for TWSIs at the international level, while acknowledging that some differences may be necessary at the local level to accommodate climatic, geographical, cultural or other issues that might exist.

TWSIs should be designed and installed based on a simple, logical and consistent layout. This will enable tactile indicators to facilitate not only the independent travel of blind or vision-impaired persons in places they frequently travel, but also to support their independent travel in places they visit for the first time.

Currently, there are several forms of TWSIs, but the ability to detect differences in tactile patterns through the soles of the shoes or the long white cane varies depending on individual differences. Therefore, the consolidated findings of science, technology and experience were employed to define the characteristics of TWSIs that can be detected and recognized by potential users. Additionally, in order to ensure that TWSIs achieve maximum effect in conveying information, it is important that they be installed in or on a smooth surface where blind or vision-impaired persons can identify them without interference from an irregular walking surface.

It is also necessary to ensure that TWSIs can be effectively used by vision-impaired persons as well as people who are blind. For this purpose, TWSIs should be easily detectable through use of residual vision. This is achieved through visual contrast between TWSIs and the surrounding or adjacent surface. Visual contrast is influenced primarily by luminance contrast, and secondarily by difference in colour or tone. In order to have good visibility, it is necessary to have sufficient illumination without glare and it is important to maintain the visual contrast between TWSIs and the surrounding or adjacent surface.

While TWSIs should be effective for blind or vision-impaired persons, attention should also be paid to their surface structure and materials in order to ensure that all pedestrians, including those with impaired mobility, can safely and effectively negotiate them.

TWSIs are installed in public facilities, buildings used by many people, railway stations and on sidewalks and other walking surfaces. Attention patterns may be installed in the vicinity of pedestrian crossings, at-grade kerbs, railway platforms, stairs, ramps, escalators, travelators, elevators, etc. Guiding patterns may be used alone or in combination with attention patterns in order to indicate the walking route from one place to another.

Assistive products for blind and vision-impaired persons — Tactile walking surface indicators

1 Scope

This International Standard provides product specifications for tactile walking surface indicators (TWSIs) and recommendations for their installation in order to assist in the safe and independent mobility of blind or vision-impaired persons.

This International Standard specifies two types of TWSIs: attention patterns and guiding patterns. Both types can be used indoors and outdoors throughout the built environment where there are insufficient cues for wayfinding, or at specific hazards.

Some countries have adopted other designs of TWSIs based on the consolidated findings of science, technology and experience, ensuring that they can be detected and distinguished by most users. National standards, regulations and guidelines governed by national legislation specify where TWSIs are to be used. This International Standard is not intended to replace requirements and recommendations contained in such national standards, regulations or guidelines.

2 Terms and definitions

For the purposes of this document, the following terms and definitions apply.

2.1

attention pattern

TWSI design, calling attention to a hazard only, or to hazards and decision points

NOTE Attention patterns can be installed in the vicinity of pedestrian crossings, at-grade kerbs, railway platforms, stairs, ramps, escalators, travelators, elevators, etc.

2.2

at-grade kerb

flush kerb

kerb whereby the edge of the walkway is at the same level as adjoining vehicular ways

NOTE See Figures B.10 and B.11.

2.3

CIE Y value

tristimulus value Y of the CIE 1931 standard colorimetric system for reflecting objects

NOTE 1 The CIE Y value equals the percentage value of the luminous reflectance.

NOTE 2 $Y = 0$ denotes the reflectance of an absolutely black object (no light is reflected). $Y = 100$ denotes the reflectance of a perfectly white object (no light is absorbed or transmitted).

2.4

decision point

intersection or change of direction along a path of travel defined by TWSIs

2.5

discrete units

individual domes, cones or elongated bars that are embedded into the ground or floor surfaces

ISO 23599:2012(E)

2.6

effective depth

distance between the detectable edges of the TWSIs when measured in the principal direction of travel

NOTE See Figure 1.

2.7

effective width

distance between the detectable edges of the TWSIs when measured perpendicular to the principal direction of travel

NOTE See Figure 1 and Figure 2.

2.8

guiding pattern

TWSI design, indicating a direction of travel or a landmark

NOTE Guiding patterns can be used alone or in combination with attention patterns in order to indicate the walking route from one place to another.

2.9

hazard

any area or element in, or adjacent to, a direction of travel, which may place people at risk of injury

2.10

illuminance

amount of luminous flux to a surface per unit area

NOTE 1 The SI unit for illuminance is lux (lx).

NOTE 2 See Reference [6] for further details.

2.11

integrated units

domes, cones or elongated bars on a base surface or plate, incorporated as a single unit

2.12

luminance

amount of light reflected or emitted from a surface in a given direction

NOTE 1 The SI unit for luminance is candela per square metre (cd/m^2).

NOTE 2 See Reference [6] for further details.

2.13

luminance contrast

value of comparison of the luminance of two surfaces

2.14

LRV

light reflectance value

proportion of visible light reflected by a surface at all wavelengths and directions when illuminated by a light source

NOTE 1 LRV is also known as the luminance reflectance factor.

NOTE 2 LRV is expressed on a scale of 0 to 100, with a value of 0 points for pure black and a value of 100 points for pure white.

2.15

reflectance

ratio of light reflected in a given direction by a surface

NOTE See Reference [6] for further details.

2.16

TWSI

tactile walking surface indicator

standardized walking surface used for information by blind or vision-impaired persons

2.17

truncated domes or cones

type of attention pattern also referred to as flat-topped domes or cones

3 General provisions

3.1 General principles

Wayfinding and mobility can be achieved through good design of facilities, including clear accessible paths of travel with built and natural guiding elements, such as edges and surfaces that can be followed tactually and visually. TWSIs should not be a substitute for poor design.

TWSIs shall be installed where no built or natural guiding elements can be provided.

Though TWSIs are used by blind or vision-impaired persons, the design and installation of TWSIs shall take into consideration the needs of people with mobility impairments.

a) All TWSIs shall:

- be easily detectable from the surrounding or adjacent surface by raised tactile profiles and visual contrast;
- maintain detectability throughout their lives;
- be designed to prevent tripping;
- be slip-resistant;
- be used in a logical and sequential manner;
- be installed consistently to enable them to be interpreted by users; and
- be of sufficient depth in the direction of travel to provide adequate detectability and appropriate response by the users, such as stopping and turning.

b) Attention TWSIs shall:

- be distinguishable from guiding TWSIs; and
- extend across the full width of an accessible path of travel and perpendicular to the direction of travel when approaching a hazard.

3.2 Detecting and distinguishing TWSIs

3.2.1 General

TWSIs shall be easily detectable from the surrounding or adjacent surface by raised tactile profiles and visual contrast. TWSIs shall be distinguishable from each other.

3.2.2 Tactile contrast

TWSIs shall be detectable by blind or vision-impaired persons through the soles of their shoes and by a long white cane.

When attention patterns and guiding patterns are combined, blind or vision-impaired persons shall be able to distinguish clearly between them, identify both and remember the meaning of each one.

ISO 23599:2012(E)

Surrounding or adjacent surfaces shall be smooth to enable TWSIs to be detected and distinguished (see 4.2).

3.2.3 Visual contrast

TWSIs shall be readily detectable and distinguishable from the surrounding or adjacent surfaces by visually impaired people. Perception of visual contrast is enhanced by high illumination (see 4.3 and Annex A).

3.2.4 Design for prevention of tripping

Truncated domes or cones and elongated bars shall have bevelled or rounded edges to decrease the likelihood of tripping and to enhance safety and negotiability for people with mobility impairments.

4 Requirements and recommendations

4.1 Specifications for shape and dimensions of TWSIs

4.1.1 General

TWSIs shall be easily detectable from the surrounding or adjacent surface by raised tactile profiles. This can be achieved by complying with the shape and dimensions specified below.

4.1.2 Attention patterns

4.1.2.1 Arrangements

Truncated domes or cones should be arranged in a square grid, parallel or diagonal at 45° to the principal direction of travel (see Figure 1).

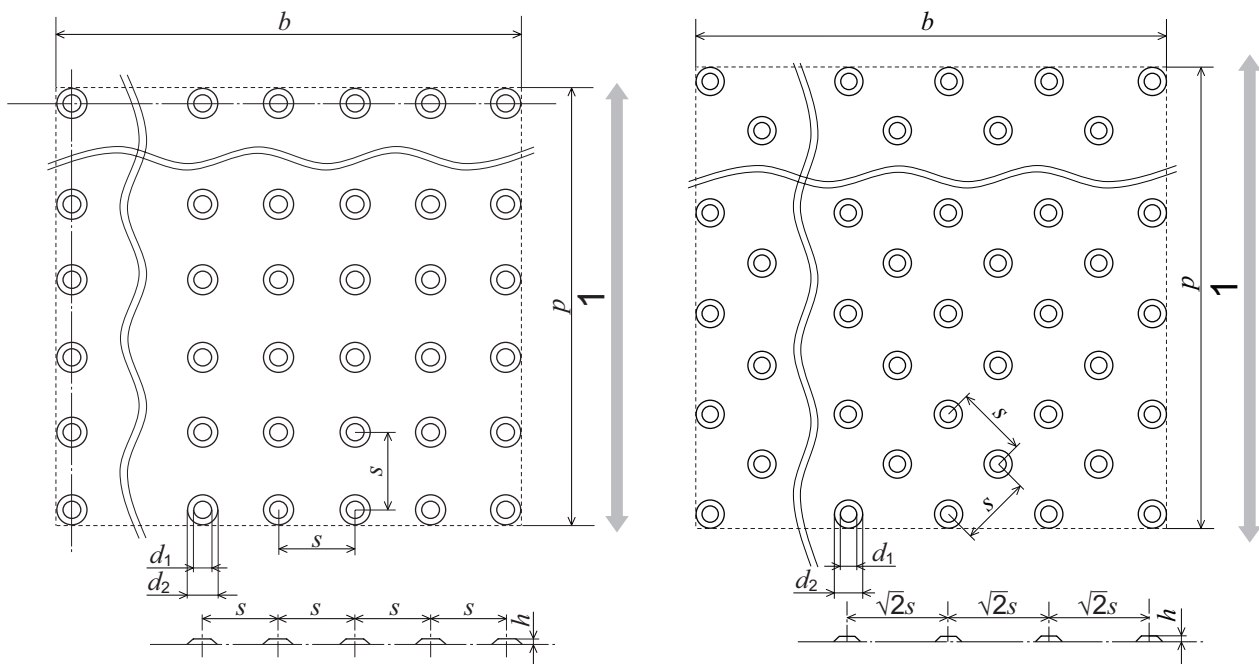

a) Parallel to the principal direction of travel

b) Diagonal at 45° to the principal direction of travel

Key

- 1 principal direction of travel
- s* spacing between the centres of adjacent truncated domes or cones
- d*₁ top diameter of truncated domes or cones
- d*₂ bottom diameter of truncated domes or cones
- h* height of truncated domes or cones
- b* effective width
- p* effective depth

Figure 1 — Spacing and dimensions of truncated domes or cones

4.1.2.2 Height

The height of truncated domes or cones shall be 4 mm to 5 mm (see Figure 2).

In indoor environments with exceptionally smooth surfaces, the minimum height of 4 mm may be preferable.

NOTE When truncated domes or cones are surrounded by exceptionally smooth surfaces, such as terrazzo, plastic or rubber, they can be detected more easily than when they are surrounded by rougher surfaces, such as brushed concrete, bricks or manufactured pavers. A height that is more than what is necessary for reliable detection can cause tripping.

4.1.2.3 Diameter

The top diameter of truncated domes or cones shall range from 12 mm to 25 mm, as shown in Table 1, and the bottom diameter of truncated domes or cones shall be (10 ± 1) mm greater than the top diameter (see Figure 1).

NOTE Systematic research^{[32][33]} carried out on truncated domes or cones of various dimensions indicates that a top diameter of 12 mm is the optimal size for blind or vision-impaired persons to detect and distinguish through the soles of their shoes. Experiences indicate that the optimal top diameter for other groups within the community could be greater.

4.1.2.4 Spacing

The spacing refers to the shortest distance between the centres of two adjacent truncated domes or cones which may be parallel or diagonal at 45° to the direction of travel. The spacing shall be within the ranges shown in relation to the top diameter in Table 1. The tolerance of the top diameter shall be ± 1 mm.

Table 1 — Top diameter and corresponding spacing of truncated domes or cones

Top diameter of truncated domes or cones mm	Spacing mm
12	42 to 61
15	45 to 63
18	48 to 65
20	50 to 68
25	55 to 70

ISO 23599:2012(E)

4.1.3 Guiding patterns

4.1.3.1 Arrangements

A guiding pattern shall be constructed of parallel flat-topped elongated bars (see Figure 2) or sinusoidal ribs (see Figure 3).

NOTE Flat-topped elongated bars are the most commonly used guiding pattern, though sinusoidal rib patterns are used in geographic areas where snow is common. Sinusoidal patterns are less easily damaged by snow ploughs than flat-topped bars.

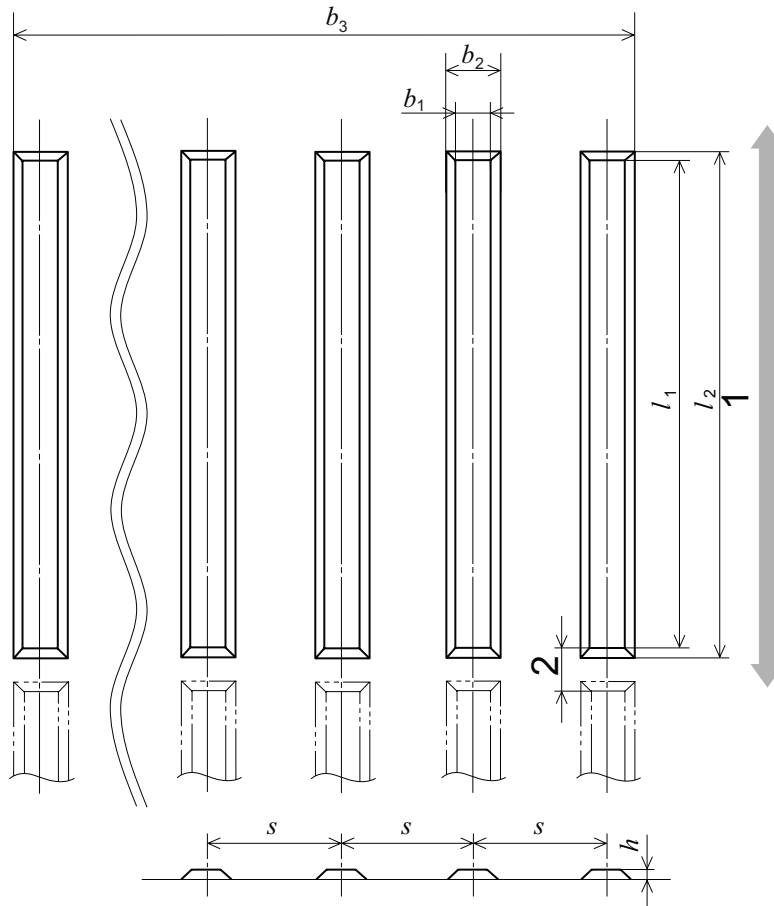

Key

- 1 principal direction of travel
- 2 drainage gap between the top of flat-topped elongated bars
- b_1 top width of flat-topped elongated bars
- b_2 bottom width of flat-topped elongated bars
- s spacing between the axes of adjacent flat-topped elongated bars
- h height of flat-topped elongated bars
- l_1 length of the top of flat-topped elongated bars
- l_2 length of the base of flat-topped elongated bars
- b_3 effective width

Figure 2 — Spacing and dimensions of flat-topped elongated bars

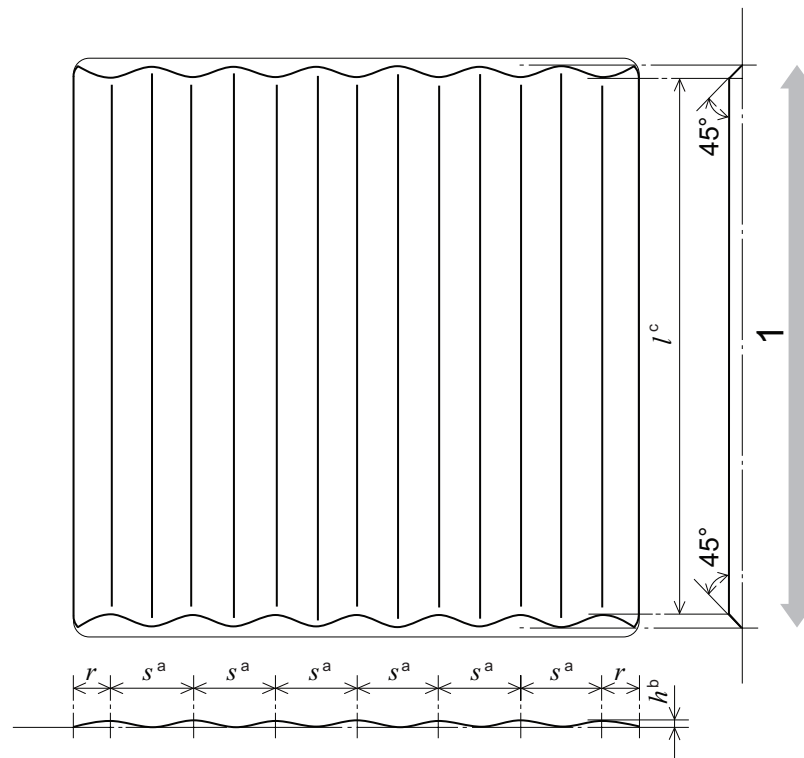

Key

- 1 principal direction of travel
- r distance between the edge of the pattern and the axis closest to the edge ($0,5 \times s$)
- s spacing between the axes of adjacent sinusoidal ribs
- h height of sinusoidal ribs
- l length of the top of sinusoidal ribs
- a 40 to 52 mm.
- b 4 to 5 mm.
- c ≥ 270 mm.

Figure 3 — Spacing and dimensions of sinusoidal ribs

4.1.3.2 Specifications for flat-topped elongated bars

4.1.3.2.1 Height

The height of flat-topped elongated bars shall be 4 mm to 5 mm (see Figure 2).

In indoor environments with exceptionally smooth surfaces, the minimum height of 4 mm may be preferable.

NOTE When flat-topped elongated bars are surrounded by exceptionally smooth surfaces, such as terrazzo, plastic or rubber, they can be detected more easily than when they are surrounded by rougher surfaces, such as brushed concrete, bricks or manufactured pavers. A height that is more than what is necessary for reliable detection can cause tripping.

4.1.3.2.2 Width

The top width of flat-topped elongated bars shall range from 17 mm to 30 mm, as shown in Table 2. The bottom width shall be (10 ± 1) mm wider than the top (see Figure 2).

NOTE Systematic research^{[32][33]} carried out on flat-topped elongated bars of various dimensions indicates that a top width of 17 mm is the optimal size for blind or vision-impaired persons to detect and distinguish through the soles of their shoes. Experiences indicate that the optimal top width for other groups within the community could be greater.

ISO 23599:2012(E)

4.1.3.2.3 Spacing

The spacing refers to the distance between the axes of adjacent flat-topped elongated bars. The distance shall be in relation to the top width, as shown in Table 2. The tolerance of the top width shall be ± 1 mm.

Table 2 — Top width and corresponding spacing of axes of flat-topped elongated bars

Top width of flat-topped elongated bars mm	Spacing mm
17	57 to 78
20	60 to 80
25	65 to 83
30	70 to 85

4.1.3.2.4 Length

The top length of flat-topped elongated bars shall be more than 270 mm and the bottom length shall be (10 ± 1) mm longer than the top. Where there is a risk of water ponding between the flat-topped elongated bars, a drainage gap of 10 mm to 30 mm shall be provided (see Figure 2).

NOTE It is easier for blind or vision-impaired persons to follow guiding patterns that are as continuous as possible.

4.1.3.2.5 Continuity

The distance between the ends of flat-topped elongated bars should be no more than 30 mm.

4.1.3.3 Specifications for sinusoidal rib pattern

4.1.3.3.1 Height of wave crests

The difference in level between the wave crest and the wave trough of sinusoidal rib patterns shall be 4 mm to 5 mm (see Figure 3).

In indoor environments with exceptionally smooth surfaces, the minimum height of 4 mm may be preferable.

NOTE When sinusoidal rib patterns are surrounded by exceptionally smooth surfaces, such as terrazzo, plastic or rubber, they can be detected more easily than when they are surrounded by rougher surfaces, such as brushed concrete, bricks or manufactured pavers. A height that is more than what is necessary for reliable detection may cause tripping.

4.1.3.3.2 Spacing between wave crests

The distance between the axes of two adjacent wave crests of sinusoidal rib patterns shall be 40 mm to 52 mm (see Figure 3).

4.1.3.3.3 Length of sinusoidal ribs

The length of the sinusoidal ribs should be at least 270 mm. Where there is a risk of water ponding between the sinusoidal bars, a drainage gap of 10 mm to 30 mm shall be provided.

4.2 Surrounding or adjacent surfaces

Surrounding or adjacent surfaces shall be smooth to enable TWSIs to be detected and distinguished. Gaps between joints should be avoided or shall have a maximum of 10 mm in width and 2 mm in depth. For paving units with bevelled edges, the width of the gap shall be measured on the top of the paving units (see Figure 4).

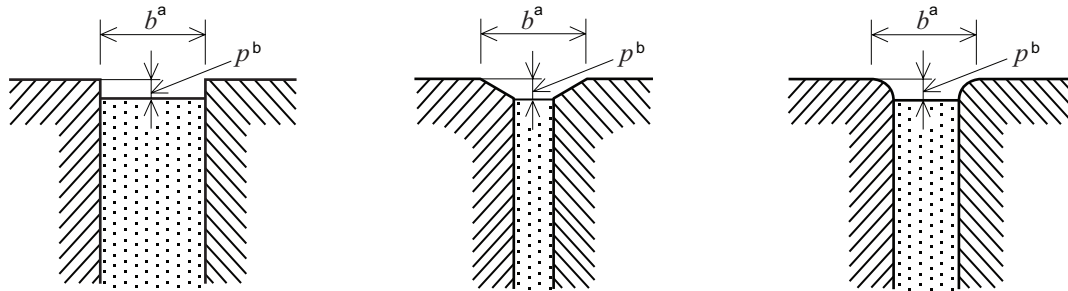

Key

b width of the gaps between joints

p depth of the gaps between joints

a ≤ 10 mm.

b ≤ 2 mm.

Figure 4 — Gaps between joints

When more than 6 % of the surrounding or adjacent surface area is covered with gaps, a smooth surface shall be provided on either side of the TWSIs, extending to a minimum width of 600 mm, to ensure the required tactile contrast.

EXAMPLE For paving units equal to or less than 200 mm × 200 mm, the gaps would be a maximum of 5,5 mm.

4.3 Visual contrast

4.3.1 General

Visual contrast has two components: luminance contrast and difference in colour. For vision-impaired persons, luminance contrast is essential. Difference in colour or tone may supplement luminance contrast.

4.3.2 Luminance contrast

The luminance contrast value between TWSIs and surrounding or adjacent surfaces shall be greater than 30 % using the Michelson Contrast formula.

When TWSIs are discrete units, luminance contrast should be 50 % or greater.

Where TWSIs are used for hazards, the luminance contrast value should be 50 % or greater.

The reflectance value (CIE Y value) of the lighter surface shall be a minimum of 40 points.

When the required luminance contrast between TWSIs and the surrounding or adjacent surface cannot be achieved, a continuous adjoining band of compliant contrast shall be used. The contrasting band shall have a minimum width of 100 mm.

4.3.3 Calculation of the luminance contrast value

The luminance contrast value (%), shall be calculated using the following formula, known as Michelson Contrast, C_M :

$$C_M = \frac{(L_1 - L_2)}{(L_1 + L_2)} \times 100$$

where

L_1 is the value of luminance on a lighter surface, expressed in cd/m^2 ;

L_2 is the value of luminance on a darker surface, expressed in cd/m^2 .

ISO 23599:2012(E)

When luminance values are not available, but CIE Y values are available, the values Y_1 and Y_2 can be substituted for L_1 and L_2 .

NOTE The CIE Y value is identical to the LRV.

When the CIE Y values or the LRVs of the two surfaces to be compared are known, these values can be used to determine the luminance contrast. Otherwise, a measurement of luminance or reflectance is required to determine the luminance contrast. For measurement methods, see A.2.

4.3.4 Maintenance of minimum luminance contrast

The minimum luminance contrast between TWSIs and surrounding or adjacent surfaces shall be achieved and maintained throughout their life. Deterioration and maintenance shall be considered at installation.

4.3.5 Measurement condition

Luminance and reflectance values should be measured under stable or controlled lighting conditions and in dry and wet conditions, as appropriate. For the measurement method, see A.2.

4.3.6 Difference in colour or tone

Difference in colour or tone between TWSIs and surrounding or adjacent surfaces may be used to increase detectability.

Combinations of red tones and green tones shall be avoided because the most common colour deficiency is of the red-green type.

NOTE 1 Vision-impaired persons often have deficient colour vision. They can, however, retain luminance sensitivity even when colour sensitivity is severely decreased.

NOTE 2 Safety yellow, as defined in ISO 3864-1, has the best colour conspicuity (according to research into vision-impaired persons^{[45][48][49]}).

4.3.7 Illumination

TWSIs should be sufficiently illuminated to ensure visual detection by vision-impaired persons.

4.4 Materials

TWSIs shall be made of materials that are durable and slip-resistant.

NOTE Refer to national standards for slip resistance.

4.5 Installation

4.5.1 General

This subclause gives the basic principles and specifications for the installation of TWSIs. Examples are provided in Annex B.

National requirements for the installation of TWSIs take into consideration existing national conditions, design requirements for the accessible built environment, and national standards, regulations or guidelines governed by national legislation.

For safety considerations, minimum depth and width dimensions for installation of TWSIs might need to be greater than those specified in this International Standard, because greater depth and width dimensions increase the probability of detection.

When TWSIs are embedded as integrated units, the base of the TWSIs shall be level with the surrounding or adjacent surface. When integrated units are applied on top of existing surfaces, the maximum height of the base plate shall not exceed 3 mm and the TWSIs shall have bevelled edges (see Figure 5).

TWSIs shall be fixed to prevent the edge from lifting.

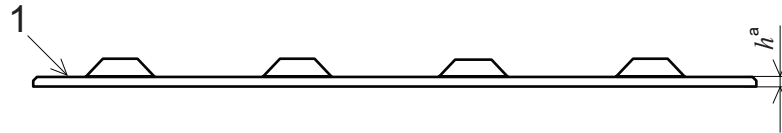

Key

1 base plate of the integrated TWSI units

h height of the base plate

a ≤ 3 mm.

Figure 5 — Base plate of integrated TWSI surface and its height

4.5.2 Principles for installation of TWSIs

When used as a system to aid orientation and safety, guiding and attention patterns shall be used in a logical, sequential manner, with beginning and end points, between which intersections, decision points or hazards are indicated.

The beginning of a system shall be clearly defined and easy to locate in conjunction with built and natural guiding elements.

TWSIs may also be used individually to indicate hazards or locations.

4.5.3 Principles for installation of attention patterns

The effective depth and width of attention patterns shall be at least 560 mm.

NOTE 1 An exception to this is railway platforms, where national regulations, standards and guidelines governed by national legislation take precedence.

When an attention pattern is used to indicate a hazard, it shall have a minimum effective depth of 560 mm. Greater depth may be needed for safety, particularly when the attention pattern indicates a hazard in the direct line of travel.

When an attention pattern is used to indicate a hazard, it shall extend the full width of the hazard, from each direction from which the hazard can be approached, and should be set back a minimum distance of 300 mm from the hazard.

Where no set-back is provided, a greater depth of the attention pattern should be used to provide greater certainty of detection and a longer stopping distance.

NOTE 2 The definition of a hazard can vary by situation and by country.

4.5.4 Principles for installation of guiding patterns

When a guiding pattern is used to designate a path of travel, it shall have a minimum effective width of 250 mm.

Where a guiding pattern of TWSIs needs to be detected by a person approaching at an angle, it shall have a minimum effective width of 550 mm.

A minimum clear path of travel of 600 mm shall be provided on both sides of a guiding pattern.

NOTE For wheelchair users, a clear path of travel of 600 mm is not sufficient. Considerations for wheelchair users are specified in ISO 21542.

Annex A (informative)

Luminance contrast

A.1 Formula for calculating luminance contrast

Different formulae for calculating luminance contrast are used around the world. In this International Standard, minimum contrast values are given using the Michelson formula. When other formulae are used, the equivalent minimum contrast values can be determined in order to achieve the perceived visual contrast as required in this International Standard. Table A.1 shows comparable minimum contrast values for some formulae.

Table A.1 — Comparable minimum values

	Michelson $\frac{(L_1 - L_2)}{(L_1 + L_2)} \times 100$ %	Weber $\frac{(L_1 - L_2)}{L_2} \times 100$ %	LRV $LRV_1 - LRV_2$			Sapolinski $\frac{125(Y_1 - Y_2)}{Y_1 + Y_2 + 25}$ %		
			$LRV_1=40$	$LRV_1=50$	$LRV_1=60$	$Y_1=40$	$Y_1=50$	$Y_1=60$
Minimum contrast value	30	46	18	23	28	27	28	30
Minimum for discrete units	40	57	23	29	34	35	37	39
Minimum for hazards	50	67	27	33	40	43	45	48

NOTE L is the measured luminance of a surface and Y is the luminance reflectance. Where L appears in a formula, Y can be used instead. The required minimum contrast for the Sapolinski formula depends on the reflectance of the lighter surface, Y_1 .

Conversion from the Michelson contrast, C_M , to the Weber contrast, C_W :

$$C_W = \frac{2 \times C_M}{100 + C_M} \quad (\text{A.1})$$

where C_M is the Michelson contrast, on a scale of 1 to 100.

Conversion from the Michelson contrast, C_M , to the Sapolinski contrast, C_S :

$$C_S = \frac{10 \times L_1 \times C_M}{8 \times L_1 + C_M + 100} \quad (\text{A.2})$$

where C_M is the Michelson contrast, on a scale of 1 to 100.

NOTE 1 Some countries use the LRV method for expressing visual contrast. The recommended visual contrast is described as the difference in LRV that is equivalent to the CIE Y value of the TWSI and the adjacent surface ($LRV_1 - LRV_2$). The instrument required to take LRV measurements is a sphere-type spectrophotometer. The general specification details are described in Reference [11].

NOTE 2 The Sapolinski formula is a modification of the Michelson formula (see Reference [9]). This formula was created to secure appropriate contrast values for human eyes for two adjacent darker surfaces.

A.2 Methods for measuring the parameters required to calculate luminance contrast

A.2.1 General

Luminance contrast can be determined by measuring the luminance of the TWSI and comparing it with the luminance of the surrounding or adjacent surface, within a width of 100 mm on both sides of the TWSI. Alternatively, it can be determined by measuring the reflectance of the TWSI and comparing it to the reflectance of the surrounding or adjacent surface.

Luminance or reflectance can be measured by one of two major methods, depending on the measurement instruments:

- a) contact type, and
- b) non-contact type.

All devices should be calibrated to the spectral sensitivity of the human eye, corrected to meet the CIE photopic curve, $V(\lambda)$.

All TWSI and surrounding or adjacent surfaces should be measured under both wet and dry conditions. When textured or non-uniform surfaces are being measured, multiple measurements should be made and averaged. When discrete TWSIs are measured, the field of measurement should include only one TWSI and no surrounding or adjacent surface.

TWSIs and surrounding or adjacent surfaces should be measured under the type of illumination that is used in the relevant environment.

It is important to read the instruction manual of any instrument used, and to understand and apply the correct procedure and method of measurement.

A.2.2 Measurement with non-contact-type instruments

Non-contact-type instruments measure the luminance of a small, defined, surface area from some distance away from the surface being measured. Non-contact-type instruments are usually fixed onto a tripod stand. The surface area being measured is determined by the angle of the measurement field of the instrument and the distance of the instrument from the surface being measured.

Non-contact-type instruments have the following advantages:

- measurements can be taken at the typical angles of perception of people who use TWSIs;
- objects with colour or surface irregularities can be accurately measured, provided that the instrument used has a measurement field wide enough to include such irregularities.

Non-contact-type instruments have the following disadvantages:

- they require stable ambient light conditions for accurate measurement;
- if luminance, L , is used to determine luminance contrast, they require that the two surfaces to be compared be measured under the same light conditions.

NOTE Measurement with non-contact-type instruments is described in detail in Reference [9].

A.2.3 Measurement with contact-type instruments

Contact-type instruments are put directly on the surface to be measured. They measure the amount of light emitted by the instrument itself and reflected from the surface being measured. Since only a small area can be

ISO 23599:2012(E)

measured at one time, it is important that multiple measurements be made and averaged, especially when a surface with irregularities is measured.

All contact-type instruments measure under daylight illumination (CIE D65). Most contact-type instruments can be set to take measurements under other types of illumination.

Contact-type instruments have the following advantages:

- they are independent from environmental lighting conditions, which allows surfaces that have been measured independently to be compared;
- they are easy to use.

Contact-type instruments have the following disadvantage:

- they provide somewhat unreliable measurements of objects with surface irregularities.

NOTE An example of this method of measurement is given in Reference [11].

Annex B (informative)

Examples of installations of TWSIs in specific situations

B.1 General

This annex gives examples of installations of TWSIs in specific situations that comply with this International Standard.

Specific designs are developed country by country, taking into consideration the different physical, climatic and social situations of each country. National design standards should provide for consistent TWSI systems within a country.

This annex includes a selection of installation designs that are used in different countries and which have been adopted in the regulations, standards or guidelines of those countries under national legislation. Other designs can also comply with the principles and specifications for TWSIs stated in this International Standard.

B.2 Pedestrian crossings

Any TWSI system for pedestrian crossings adopted by a country should be applied consistently throughout that country.

When used to indicate a pedestrian crossing, attention patterns should be set back 300 mm from the edge of the sidewalk with a minimum depth of 560 mm, and should be installed perpendicular to the direction of travel across the crossing (see Figure B.1). Where no set-back is provided, a greater depth of the attention pattern should be used to provide greater certainty of detection and a longer stopping distance.

A guiding pattern or attention pattern can be used to indicate the location of a pedestrian crossing. A guiding pattern can also be used to indicate the direction of travel at a pedestrian crossing (see Figure B.1).

TWSIs should be used to help locate the push button control or the tactile walk signal for pedestrian traffic lights, or both.

When used to indicate a pedestrian crossing that has a pedestrian refuge, attention patterns should also be provided on the refuge.

Different countries have different designs for installation of TWSIs at pedestrian crossings. Figure B.1 shows the basic design and elements of the TWSI installation at a pedestrian crossing. Other designs complying with this International Standard are shown in Figures B.2, B.3, B.4, B.5, B.6, B.7, B.8 and B.9.

ISO 23599:2012(E)

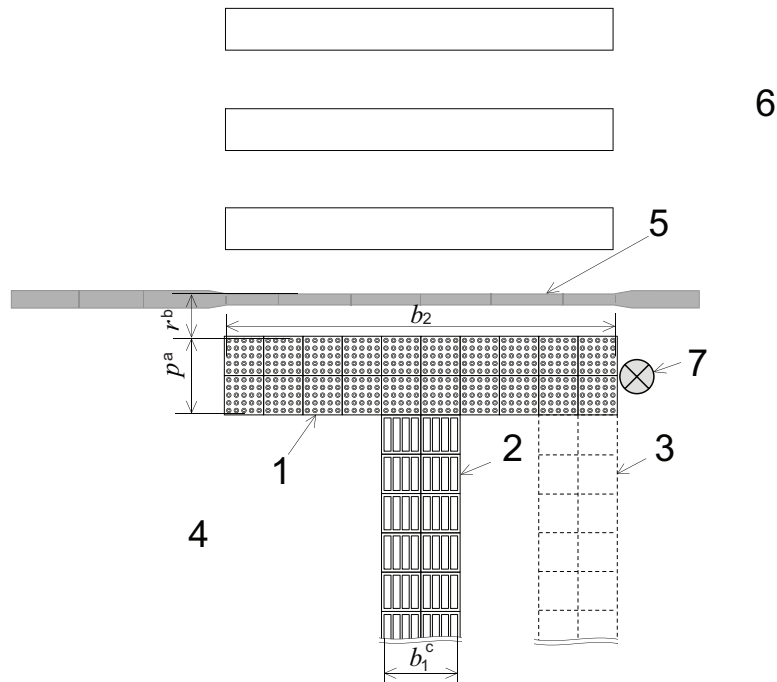

Key

- 1 attention pattern
- 2 location of the stem (installed at the centre of the effective width of the attention pattern, b_2)
- 3 location of the stem (installed at the edge of the effective width of attention pattern, b_2)
- 4 sidewalk
- 5 kerb or at-grade kerb
- 6 vehicular way
- 7 pedestrian push button
- b_1 effective width of the guiding pattern
- b_2 effective width of the attention pattern
- p effective depth of the attention pattern
- r distance of the set-back from the outer edge of the kerb or at-grade kerb to the edge of attention pattern
- a ≥ 560 mm.
- b ≥ 300 mm.
- c ≥ 550 mm.

NOTE This example shows the basic designs and elements required when installing TWSIs at pedestrian crossings, based on the principles for installation given in this International Standard.

Figure B.1 — Pedestrian crossing — Example 1

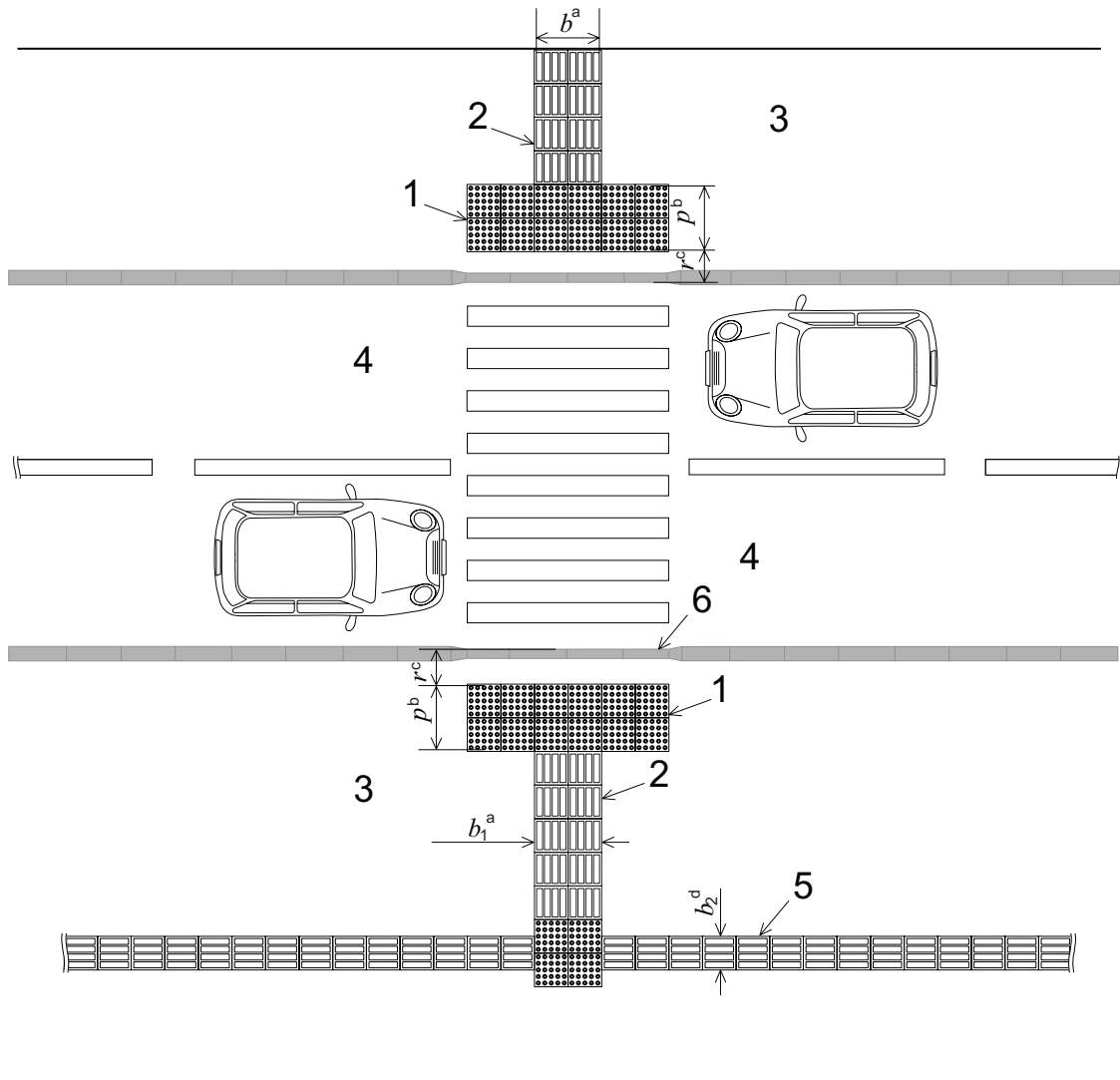

Key

- 1 attention pattern
- 2 guiding pattern (used as a stem)
- 3 sidewalk
- 4 vehicular way
- 5 guiding pattern
- 6 kerbs or at-grade kerbs
- p effective depth of the attention pattern
- b_1 effective width of the guiding pattern
- b_2 effective width of the guiding pattern
- r distance of the set-back from the outer edge of the kerb or at-grade kerb to the edge of attention pattern
- a 550 mm.
- b 560 mm.
- c ≥ 300 mm.
- d ≥ 250 mm.

NOTE This example combines the use of a guiding pattern along the sidewalk with attention patterns to indicate the intersection of the guiding pattern leading to the crossing, and the location of the crossing itself.

Figure B.2 — Pedestrian crossing — Example 2

ISO 23599:2012(E)

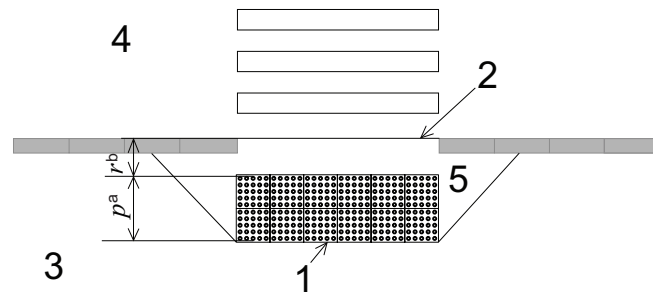

Key

- 1 attention pattern
- 2 at-grade kerb
- 3 sidewalk
- 4 vehicular way
- 5 kerb ramp
- p effective depth of the attention pattern
- r distance of the set-back from the outer edge of the at-grade kerb
- a 560 mm.
- b 300 mm.

NOTE This example shows the attention pattern on a kerb ramp set-back from the at-grade kerb, with no stem. When there is no stem to guide users to a particular location in the width of the crossing, it is important that the attention pattern extend the full width of the at-grade kerb.

Figure B.3 — Pedestrian crossing — Example 3

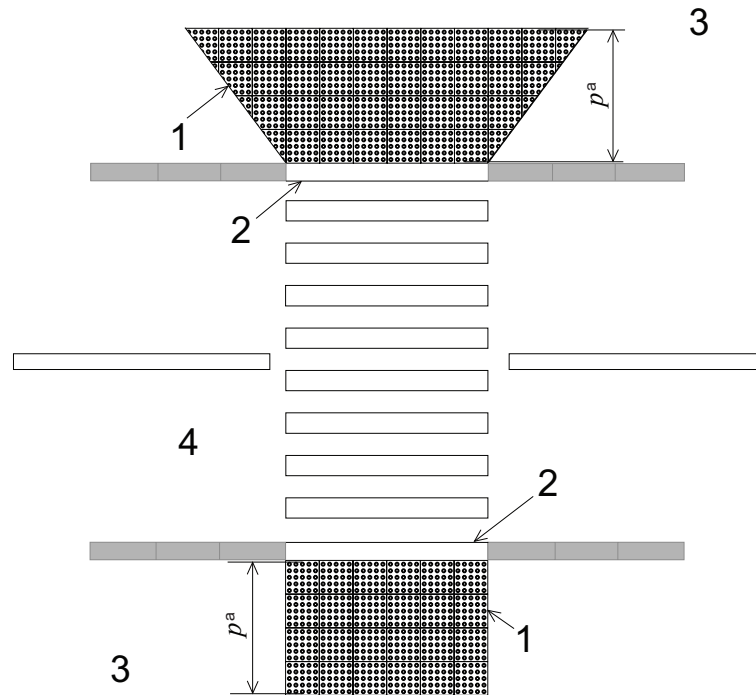

Key

- 1 attention pattern
- 2 at-grade kerb
- 3 sidewalk
- 4 vehicular way
- p effective depth of the attention pattern
- ^a 1 200 mm.

NOTE This example shows the attention pattern at a crossing where the vehicular way is raised to the same level as the pedestrian way. The attention pattern extends the full width of the at-grade kerb, with no set-back. This is important because a pedestrian who is blind or vision impaired could approach the crossing at an angle and miss the attention pattern if it is set back, continuing into the vehicular way without realizing.

Figure B.4 — Pedestrian crossing — Example 4

ISO 23599:2012(E)

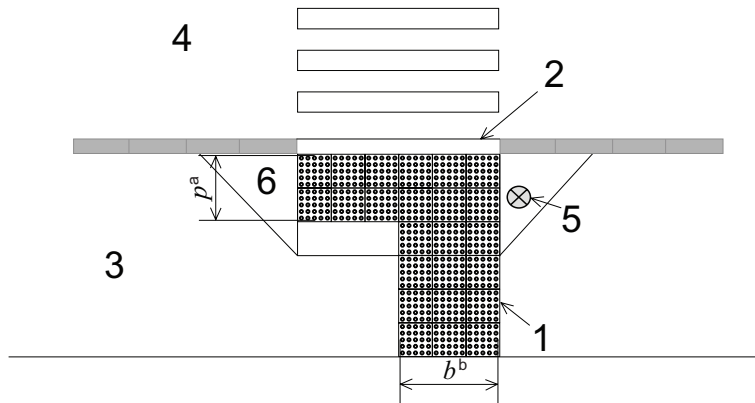

Key

- 1 attention pattern
- 2 at-grade kerb
- 3 sidewalk
- 4 vehicular way
- 5 pedestrian push button
- 6 kerb ramp

b effective width of the attention pattern

p effective depth of the attention pattern

a 800 mm.

b 1 200 mm.

NOTE This example shows the attention pattern, set immediately behind the kerb stone, across the full width of the at-grade kerb. An attention pattern stem leads to the pedestrian push button and the crossing point.

Figure B.5 — Pedestrian crossing — Example 5

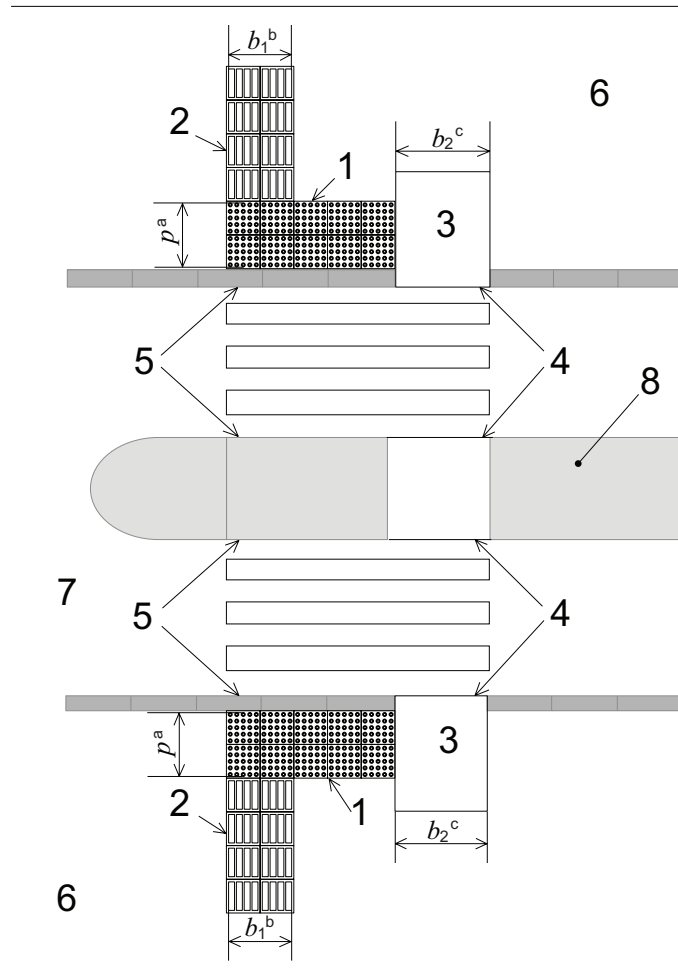

Key

- 1 attention pattern
- 2 guiding pattern (used as a stem)
- 3 kerb ramp
- 4 at-grade kerbs
- 5 kerbs
- 6 sidewalk
- 7 vehicular way
- 8 pedestrian refuge
- p effective depth of the attention pattern
- b_1 effective width of the guiding pattern
- b_2 width of the kerb ramps
- a 560 mm.
- b 550 mm.
- c 900 to 1 000 mm.

NOTE This example shows the attention pattern, set immediately behind a 50-mm-high kerb. It extends across the full width of the crossing except for the section covered by a 900 mm to 1 000 mm kerb ramp, ending at-grade. A stem of guiding pattern leads to the side of the attention pattern farthest from the kerb ramp. The guiding pattern also leads to the push button control.

Figure B.6 — Pedestrian crossing — Example 6

ISO 23599:2012(E)

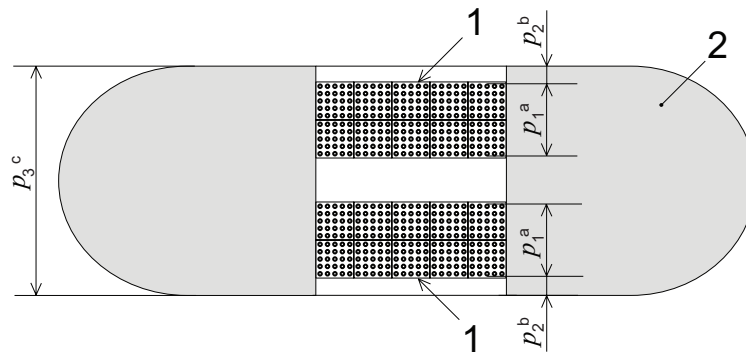

Key

- 1 attention pattern
- 2 pedestrian refuge
- p_1 effective depth of the attention pattern
- p_2 depth of the kerbs or at-grade kerbs (dimension only applicable if kerb is wide enough)
- p_3 depth of the pedestrian refuge
- a 800 mm.
- b 150 mm.
- c > 2 000 mm.

NOTE This example shows the attention pattern at both sides of a wide pedestrian refuge that is cut through to be accessible to a user. In this example, the attention pattern is 800 mm deep, and set immediately behind the kerb stones. The attention pattern alerts blind or vision-impaired pedestrians when they enter and when they are about to leave the refuge. The same arrangement can be used where the wide refuge has kerb ramps.

Figure B.7 — Pedestrian crossing — Example 7

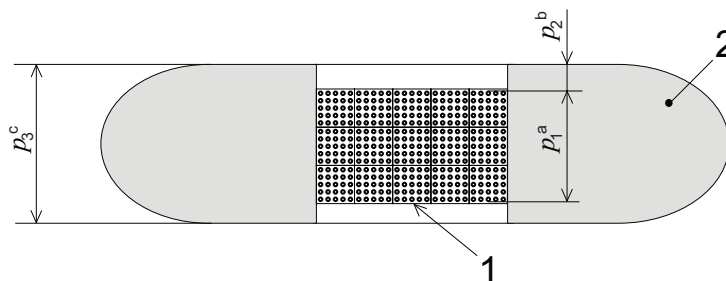

Key

- 1 attention pattern
- 2 pedestrian refuge
- p_1 effective depth of the attention pattern
- p_2 depth of the kerbs or at-grade kerbs (dimension only applicable if kerb is wide enough)
- p_3 depth of the pedestrian refuge
- a $p_3 - 300$ mm.
- b 150 mm.
- c < 2 000 mm.

NOTE This example shows the attention pattern at a narrow pedestrian refuge (<2 000 mm) that is cut through. The attention pattern covers the full depth of the refuge. This is less informative than having one attention pattern on each side of the refuge, as is possible at a wider refuge, but it does alert blind or vision-impaired pedestrians when they are at the refuge so that they can safely stop and wait.

Figure B.8 — Pedestrian crossing — Example 8

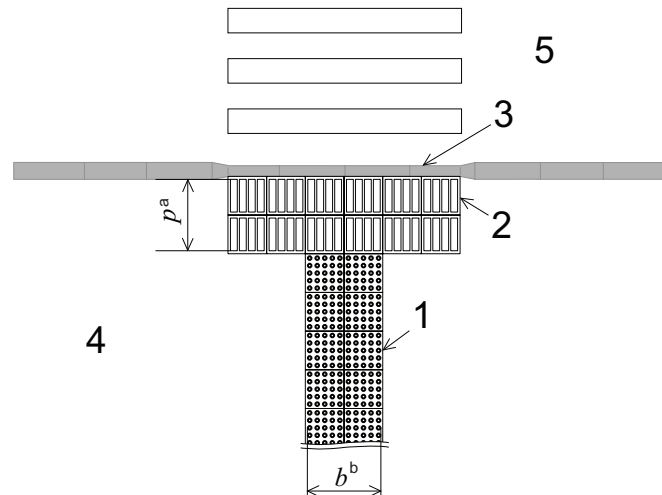

Key

- 1 attention pattern (used as a stem)
- 2 guiding pattern
- 3 kerb or at-grade kerb
- 4 sidewalk
- 5 vehicular way
- b effective width of the attention pattern
- p effective depth of the guiding pattern
- ^a 600 mm.
- ^b 900 mm.

NOTE This example shows the attention pattern installed across the full width of the sidewalk to indicate a decision point, i.e. the location of the crossing. The guiding pattern is installed across the width of the pedestrian crossing and directly behind the kerb stones. This is used to show the direction of travel across the vehicular way.

Figure B.9 — Pedestrian crossing — Example 9

B.3 At-grade kerbs

Any TWSI system for at-grade kerbs adopted by a country should be applied consistently throughout that country.

When used to indicate at-grade kerbs between sidewalks and vehicular ways, attention patterns should be set back 300 mm from the edge of at-grade kerbs.

These examples of at-grade kerbs show the minimum dimensions specified in 4.5.3 for the effective depth and width of the TWSIs and their set-back from the vehicular way (see Figures B.10 and B.11).

ISO 23599:2012(E)

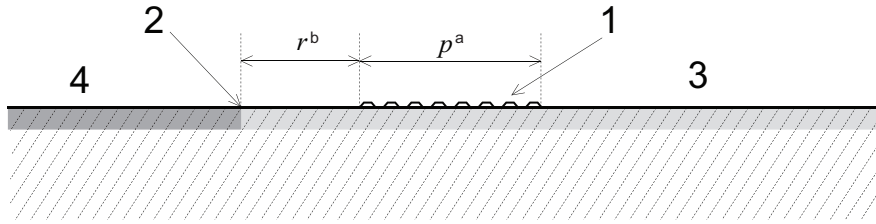

Key

- 1 attention pattern
- 2 at-grade kerbs
- 3 sidewalk
- 4 vehicular way
- p effective depth of the attention pattern
- r distance from the at-grade kerbs to the attention pattern
- a ≥ 560 mm.
- b ≥ 300 mm.

Figure B.10 — Example of a section of at-grade kerb with an attention pattern

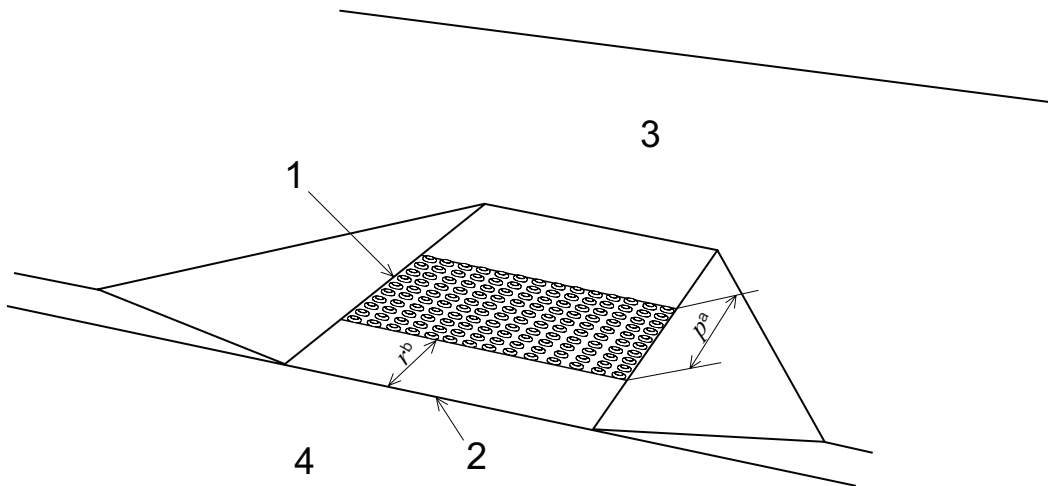

Key

- 1 attention pattern
- 2 at-grade kerbs
- 3 sidewalk
- 4 vehicular way
- p effective depth of the attention pattern
- r distance from the at-grade kerbs to the attention pattern
- a ≥ 560 mm.
- b ≥ 300 mm.

Figure B.11 — Example of a kerb ramp with an attention pattern

B.4 Railway platforms

Any TWSI system for railway platforms adopted by a country should be applied consistently throughout that country. These examples of TWSIs at railway platforms show the minimum dimensions specified in 4.5.3 for the effective depth.

When used to indicate the edge of a railway platform, attention patterns should be parallel to the platform edge and should extend the length of the platform that is accessible to passengers (see Figure B.12).

The total depth of the attention pattern and the set-back should be at least 1 060 mm (see Figure B.12).

NOTE 1 Many national regulations require that an attention pattern be set back a specific distance from the edge of the platform, or at a distance which varies in relation to the speed of the trains.

Where a guiding pattern is used on a platform, it should be limited to areas of the platform that are designed by transit authorities to be safe for passengers.

NOTE 2 The principles of this International Standard can also be applied to on-street platforms. No example is provided in this annex.

ISO 23599:2012(E)

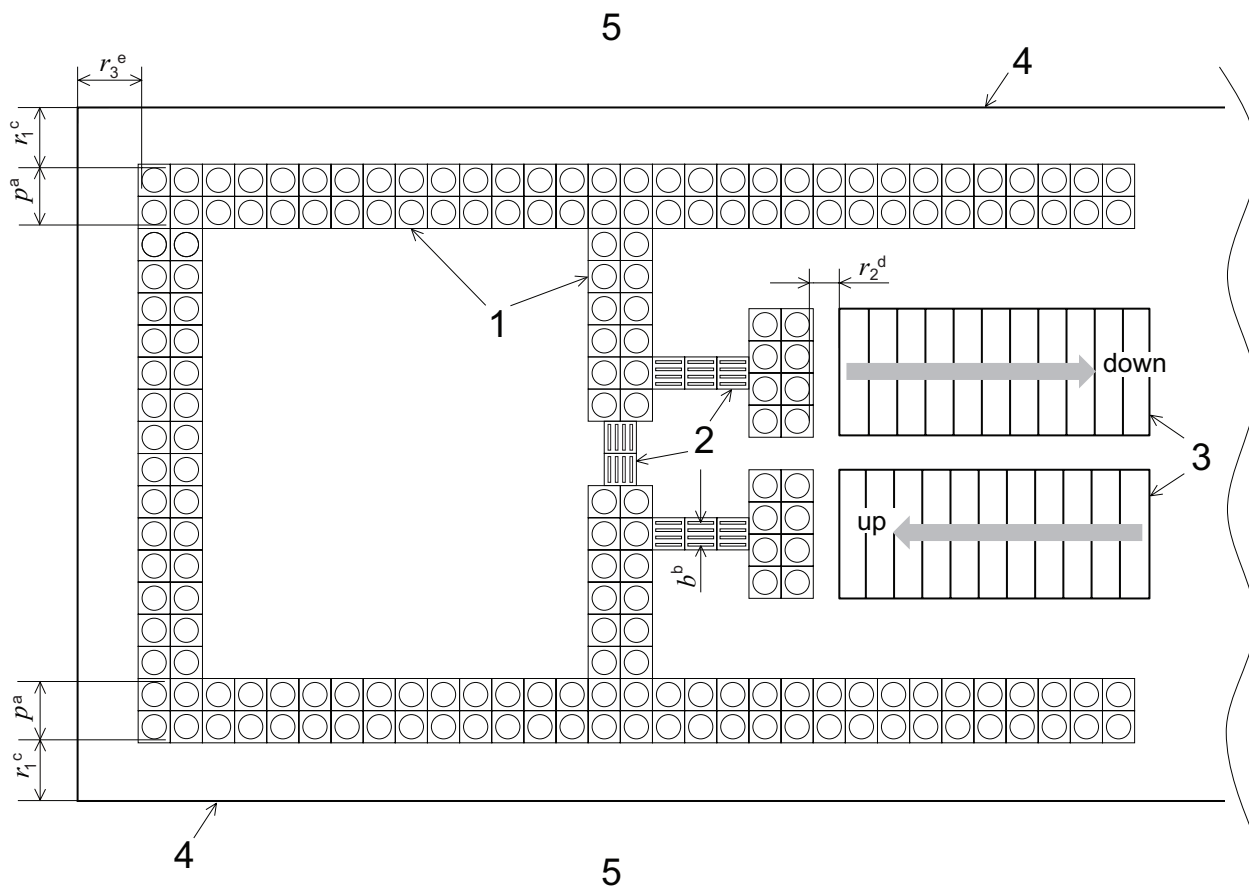

Key

- 1 attention pattern
- 2 guiding pattern
- 3 stairs
- 4 edge of the platform
- 5 railway track
- b* effective width of the guiding pattern
- p* effective depth of the attention pattern
- r*₁ distance of the set-back from the edge of the platform to the attention pattern
- r*₂ distance of the set-back from the edge of the top or bottom step nosing to the attention pattern
- r*₃ distance of the set-back from the edge of the platform to the attention pattern
- a ≥ 560 mm.
- b ≥ 250 mm.
- c ≥ 500 mm.
- d 300 to 500 mm.
- e ≥ 500 mm.

NOTE This example shows a railway platform with a system of attention patterns and guiding patterns that safely guides blind or vision-impaired travellers to all public areas of the platform and warns them when they are approaching the platform edge. The attention pattern is set back from the platform edge to give ample distance to stop after encountering the attention pattern, and to encourage blind travellers to stand far from the edge. However, a wide set-back might not be possible on narrow platforms. A very wide set-back also provides an ambiguous area between the platform edge and the attention field where a blind or vision-impaired pedestrian might not know that he or she is too close to the platform edge.

Figure B.12 — Example of dimensions and placement of attention patterns at the edge of railway platforms with a set-back

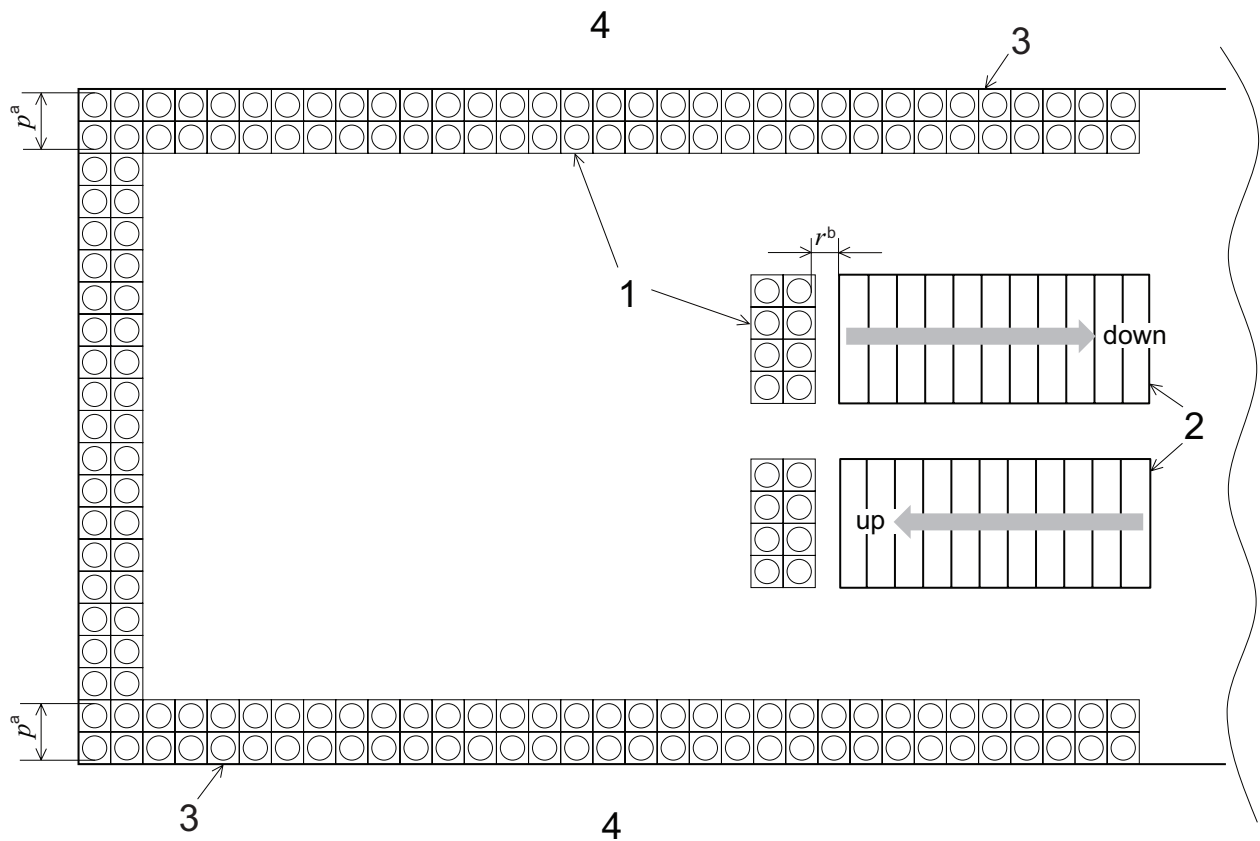

Key

- 1 attention pattern
- 2 stairs
- 3 edge of the platform
- 4 railway track
- p effective depth of the attention pattern
- r distance of the set-back from the edge of the top or bottom step nosing to the attention pattern
- a ≥ 560 mm.
- b 300 to 500 mm.

NOTE This example shows a railway platform with attention patterns only, to warn blind or vision-impaired travellers when they are at the platform edge. There is no set-back. Travellers encounter the attention pattern and then stand back from it. This design is suitable for narrow platforms and has no area of ambiguity where a traveller might not know he or she is too close to the platform edge.

Figure B.13 — Example of dimensions and placement of attention patterns at the edge of railway platforms without a set-back

B.5 Stairs

Any TWSI system for stairs adopted by a country should be applied consistently throughout that country.

When used at the approach to the top of stairs, attention patterns should be set back between 300 mm and 500 mm from the edge of the top stair nosing. When a set-back is used at the bottom of the stairs, the dimension of the set-back should be at least 1,5 times the depth of the top surface of the step (see Figure B.14).

NOTE For vision-impaired persons, a set-back from the bottom of the stairs that is close to the dimension of the top surface of the step can be mistaken for an additional step.

ISO 23599:2012(E)

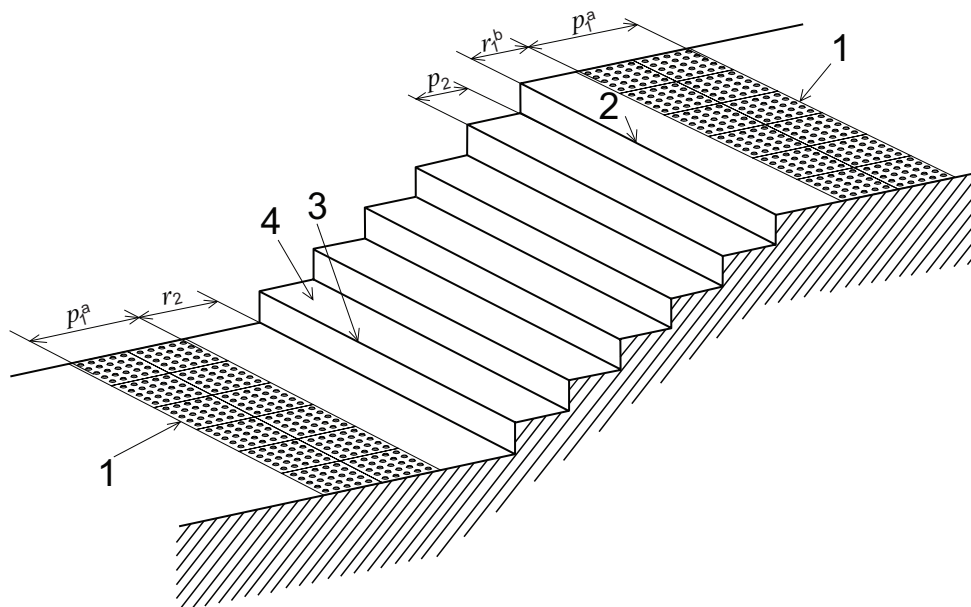

Key

- 1 attention pattern
- 2 top step nosing
- 3 bottom step nosing
- 4 top surface of the step
- p_1 effective depth of the attention pattern
- p_2 depth of the top surface of the step
- r_1 distance of the set-back from the edge of the top stair nosing to the attention pattern
- r_2 distance of the set-back from the bottom step nosing to the attention pattern ($1,5 \times p_2$)

^a ≥ 560 mm.

^b 300 to 500 mm.

NOTE This example shows dimensions and placement of attention patterns at stairs with a set-back.

Figure B.14 — Attention patterns at stairs with a set-back

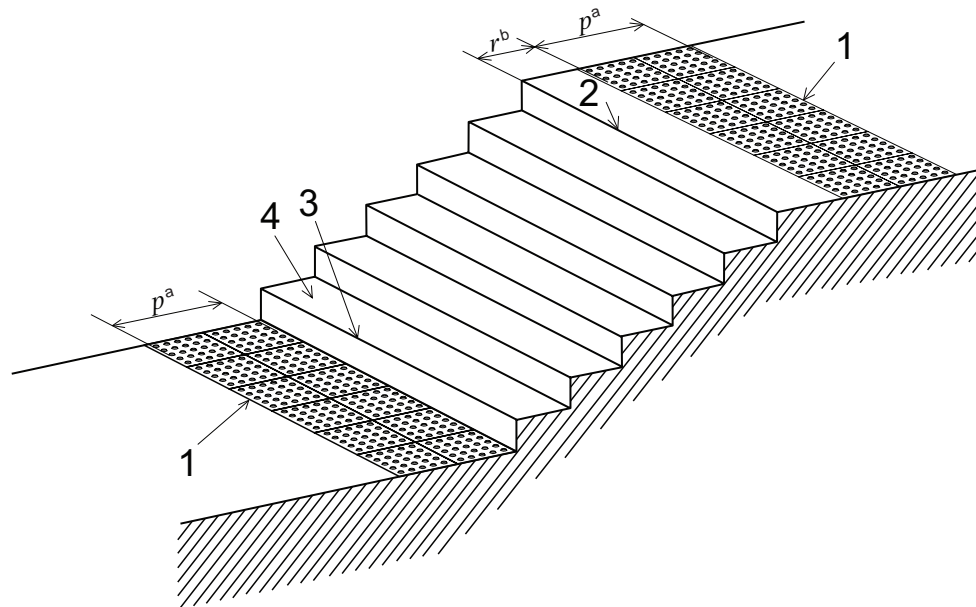

Key

- 1 attention pattern
- 2 top step nosing
- 3 bottom step nosing
- 4 top surface of the step
- p effective depth of attention pattern
- r distance of the set-back from the edge of the top stair nosing to the attention pattern
- a ≥ 560 mm.
- b 300 to 500 mm.

NOTE This example shows dimensions and placement of attention patterns at stairs without a set-back at the bottom of the stairs to provide visual contrast between TWSIs and the top surface of the first step.

Figure B.15 — Attention patterns at stairs without a set-back at the bottom

B.6 Ramps

Any TWSI system for ramps adopted by a country should be applied consistently throughout that country.

When used to indicate the location of ramps, attention patterns should be set back between 300 mm and 500 mm from the top and the bottom of the ramp (see Figure B.16).

NOTE In some countries, ramps are not considered to be a hazard for blind or vision-impaired persons. In addition, in some countries, it is considered hazardous if there are TWSIs at ramps, particularly for people with mobility impairments.

ISO 23599:2012(E)

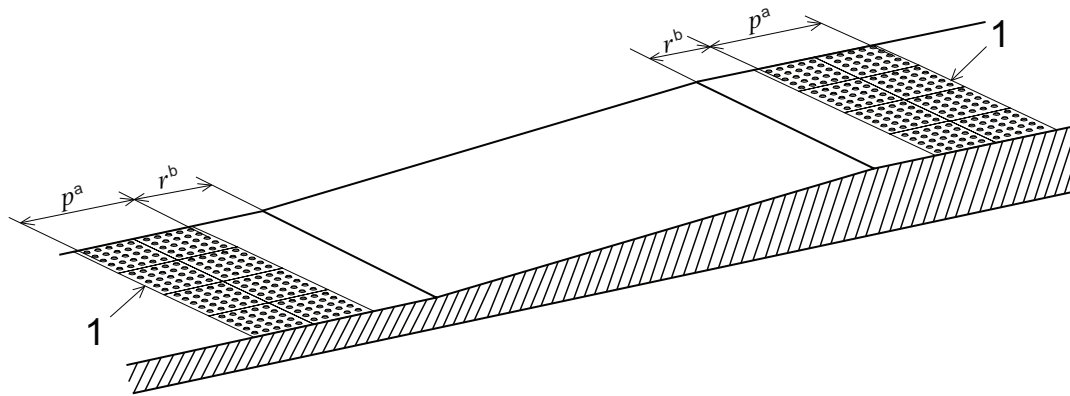

Key

- 1 attention pattern
- p effective depth of the attention pattern
- r distance of the set-back from the edge of the ramps to the attention pattern
- a ≥ 560 mm.
- b 300 to 500 mm.

Figure B.16 — Example of dimensions and placement of attention patterns at ramps

B.7 Escalators and travelators

Any TWSI system for escalators and travelators adopted by a country should be applied consistently throughout that country.

When used to indicate the location of escalators and travelators, attention patterns should be set back between 300 mm and 500 mm from the moving handrail or the fixed guard at both ends (see Figure B.17 and Figure B.18).

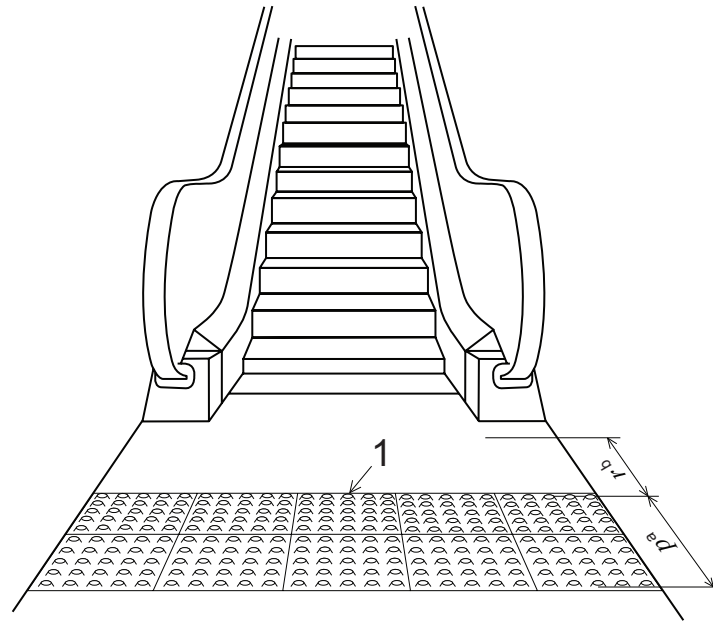

Key

- 1 attention pattern
- p effective depth of the attention pattern
- r distance of the set-back from the moving handrail to the attention pattern
- a ≥ 560 mm.
- b 300 mm to 500 mm.

NOTE A similar arrangement is required at the top of escalators and travelators.

Figure B.17 — Example of dimensions and placement of attention patterns at escalators — Front view

ISO 23599:2012(E)

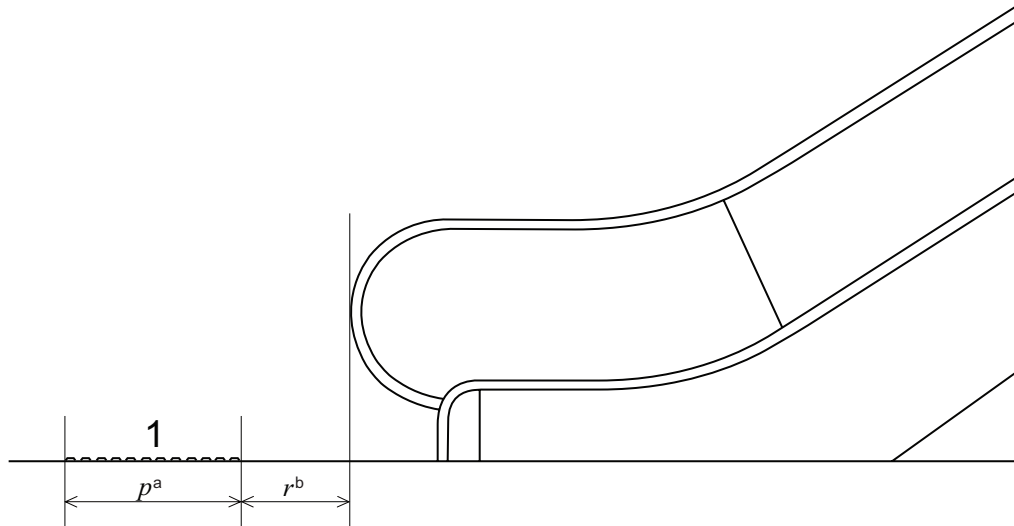

Key

- 1 attention pattern
- p effective depth of the attention pattern
- r distance of the set-back from the moving handrail to the attention pattern
- ^a ≥ 560 mm.
- ^b 300 mm to 500 mm.

Figure B.18 — Example of dimensions and placement of attention patterns at escalators — Side view

B.8 Elevators

Any TWSI system for elevators adopted by a country should be applied consistently throughout that country.

When used to indicate the location of elevators, guiding patterns should guide blind or vision-impaired persons to the elevator control panel (see Figure B.19). Attention patterns should be set back a maximum of 300 mm in front of the elevator control panel.

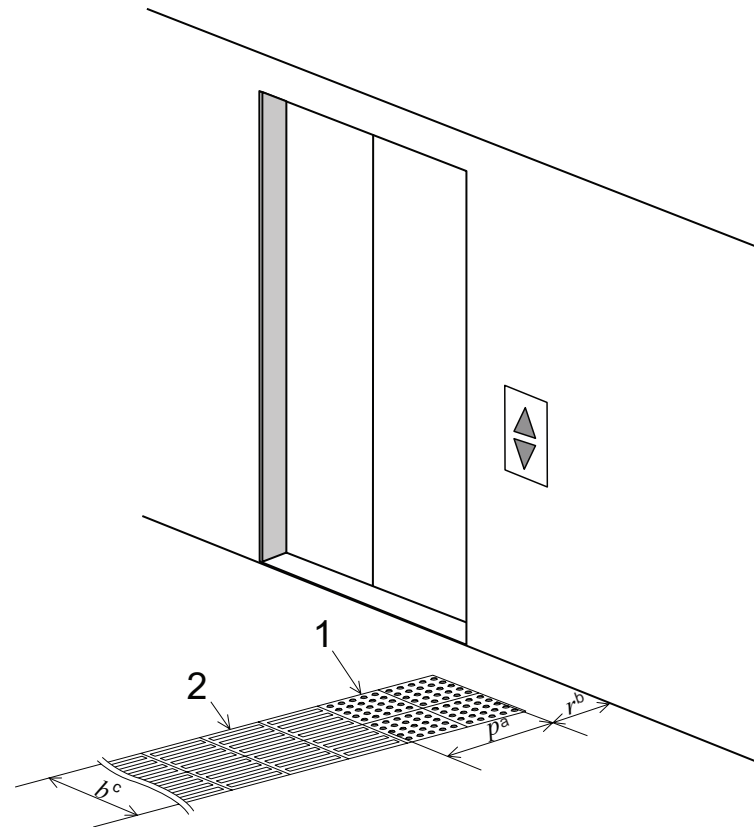

Key

- 1 attention pattern
 - 2 guiding pattern
 - p effective depth of the attention pattern
 - b effective width of the guiding pattern
 - r distance of the set-back from the wall to the attention pattern
- a ≥ 560 mm.
b ≤ 300 mm.
c ≥ 550 mm.

Figure B.19 — Example of dimensions and placement of attention patterns at elevators

B.9 Revolving doors

Any TWSI system for revolving doors adopted by a country should be applied consistently throughout that country.

When used to indicate the location of revolving doors, attention patterns should be set back a minimum of 300 mm from the arc of the entry point (see Figure B.20).

ISO 23599:2012(E)

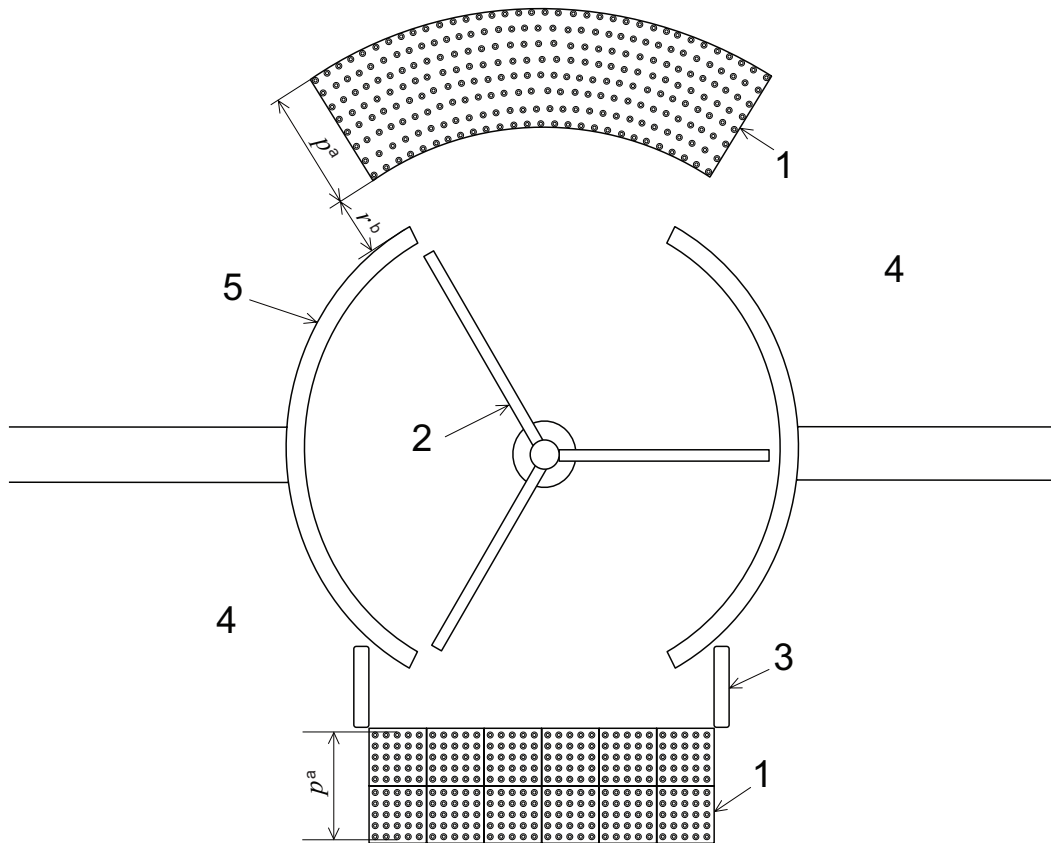

Key

- 1 attention pattern
- 2 revolving door
- 3 guard
- 4 walkway
- 5 revolving door guide
- p effective depth of the attention pattern
- r distance of the set-back from the revolving door guide to the attention pattern
- a ≥ 560 mm.
- b ≥ 300 mm.

Figure B.20 — Example of dimensions and placement of attention patterns at revolving doors

Bibliography

- [1] ISO 3864-1, *Graphical symbols — Safety colours and safety signs — Part 1: Design principles for safety signs and safety markings*
- [2] ISO 21542, *Building construction — Accessibility and usability of the built environment*
- [3] CEN/TS 15209:2008, *Tactile paving surface indicators produced from concrete, clay and stone*. Available at <http://shop.bsigroup.com>
- [4] CIE 95:1992, *Contrast and visibility*
- [5] CIE 123:1997, *Lighting needs for the partially sighted*
- [6] CIE S 017, *ILV: International Lighting Vocabulary*
- [7] CIE 1932, *Commission Internationale de l'Eclairage, Proceedings 1931*, Available at [Cambridge University Press](#)
- [8] AS/NZS 1428.4-2002, *Design for access and mobility — Part 4: Tactile indicators*
- [9] AS/NZS 1428.4.1:2009, *Design for access and mobility — Part 4.1: Means to assist the orientation of people with vision impairment — Tactile ground surface indicators*
- [10] BS 8300:2010 *Design of buildings and their approaches to meet the needs of disabled people*
- [11] BS 8493:2008, *Light reflectance value (LRV) of a surface — Method of test (+Amendment1:2010)*
- [12] BFS 2003:19 / HIN 1 *Removal of easily eliminated obstacles*. November 2003, Sweden
- [13] BFS 2004:15 - ALM *Accessibility and usability in public spaces*. September 2004, Sweden
- [14] BFS 2006:22: *Building regulations. 2008, Mandatory provisions and general recommendations*, Sweden
- [15] CSA B651-12, *Accessible design for the built environment (under development)*
- [16] DS *Outdoor areas for all — Planning and design — Guidelines for providing access for disabled persons*, 2012
- [17] DIN 32975, *Designing visual information in the public area for accessible use*
- [18] DIN 32984:2000, *Ground surface indicators in public traffic areas*
- [19] JIS T 9251:2001, *Dimensions and patterns of raised parts of tactile ground surface indicators for blind persons*
- [20] JIS TR T 0006:1999, *Methods for estimating probability and easiness of the visual impaired's recognition of bumps in tactile tiles through their soles of shoes*
- [21] NFP 98-351, *Cheminements — Insertion des handicapés — Éveil de vigilance — Caractéristiques et essais des dispositifs podo-tactiles au sol d'éveil de vigilance à l'usage des personnes aveugles ou malvoyantes*
- [22] SI 1918 Part 6: *Accessibility of the built environment: Warning and guiding means for persons with vision impairment*, 2011
- [23] SN 640 852:2005, *Taktil-visuelle Markierungen für blinde und sehbehinderte Fussgänger*
- [24] Americans with Disabilities Act and Architectural Barriers Act, *Accessibility Guidelines*. July 23, 2004, Access Board, USA. Available at http://www.fta.dot.gov/civilrights/ada/civil_rights_3884.html

ISO 23599:2012(E)

- [25] CERTU, *Dispositifs directionnels de guidage ou de repérage sur passages piétons ou trottoirs pour les personnes aveugles et malvoyantes*, Lyon, France, July 2009. Available at <http://www.certu.fr/catalogue/p2351/>
- [26] CNIB, *Access Needs of Blind and Visually Impaired Travellers in Transportation Terminals: A Study and Design Guidelines*, December 1987
- [27] Code of Federal Regulations, Title 49, Volume 1, Part 37. *Transportation Services for Individuals with Disabilities*. Revised October, 2007, USA. Available at http://fta.dot.gov/civilrights/ada/vivil_rights_3906.html
- [28] Department of Environment Transport Regions, Scottish Office, *Guidance on the use of tactile paving surfaces* 1998. Available at <http://www.dft.gov.uk/transportforyou/access/peti/guidanceontheuseoftactilepav6167>
- [29] Foundation for Promoting Personal Mobility and Ecological Transportation, Japan, *Research on Tactile Tiles for Guiding the Visually Impaired*, October, 2002
- [30] Guide Dogs UK Inclusive Streets: *Design principles for blind and partially sighted people*, 2010. Available at <http://www.guidedogs.org.uk/whatwedo/campaigns/inclusivestreets/>
- [31] National Institute of Technology and Evaluation, Japan, *Preliminary Report on Standardization Research on Visibility of Tactile Walking Surface Indicators for the Vision Impaired — Characteristics of Luminance Contrast Sensitivity of Persons with Low Visual Capacity*, 2006
- [32] National Institute of Technology and Evaluation, Japan, *Report of Fundamental Research on Standardization of Tactile Tiles for Guiding the Visually Impaired — Standardizing Patterns* (Version 1.0), 1998. Available at http://www.tech.nite.go.jp/standardE/downloadfiles/block/Blue-report_revison.pdf
- [33] National Institute of Technology and Evaluation, Japan, *Report of Fundamental Research on Standardization of Tactile Tiles for Guiding the Visually Impaired — Targeting Standardizing Patterns* (Version 1.0), 2000. Available at http://www.tech.nite.go.jp/standardE/downloadfiles/block/Red-report_revison.pdf
- [34] Province of Ontario. N148e ABE SDC. *The final proposed built environment standard*, July 2010, Canada
- [35] Accessibility Research Group Civil, Environmental, and Geomatic Engineering, University College London, *Effective kerb heights for blind and partially sighted people*, 2009. Available at <http://www.guidedogs.org/sharedsurfaces>
- [36] University College London, *Testing proposed delineators to demarcate pedestrian paths in a shared space environment*, 2008. Available at <http://www.guidedogs.org/sharedsurfaces>
- [37] BENTZEN, B.L., BARLOW, J.M. and TABOR, L. *Detectable Warnings: Synthesis of US and International Practice*, US Access Board. USA, May 2000. Available at http://accessforblind.org/dw_resources.html
- [38] BOHRINGER, D., *Testing tactile walking surface indicators with blind people, wheelchair and walking frame users – Results and conclusions*. Available at www.gfuv.de
- [39] BOLAY, F., *Requirements of blind people and people with low vision to designing accessible stairs: Inclusive design and building for disabled people and seniors*
- [40] BRIGHT, K. T., & COOK, G. K., 1999, *Project Rainbow - A research project to provide colour and contrast design guidance for internal built environments*. Chartered Institute of Building Occasional Paper 57
- [41] GALLON, C. *Tactile Surfaces in the Pedestrian Environment: Experiments in Wolverhampton*. Department of Transport UK, 1992
- [42] GALLON, C. *Tactile Surfaces in the Pedestrian Environment: Experiments in Wolverhampton*. Centre for Logistics and Transportation. Cranfield Institute of Technology, UK. Available at www.trl.co.uk
- [43] GALLON, C. *The Development of Training Methods to Enable Visually Impaired Pedestrians to Use Tactile Surfaces*. Centre for Logistics and Transportation. Cranfield Institute of Technology, UK. November 1992. Available at <http://trid.trb.org/view.aspx?id=660838>

- [44] GALLON, C., OXLEY, P. and SIMMS, B. *Tactile Footway Surfaces for the Blind*. Department of Transport UK. November 1988. Available at www.trl.co.uk
- [45] JENNESS, J. and SINGER, J. *Visual Detection of Detectable Warning Materials by Pedestrians with Visual Impairments. Final Report*. Prepared for Federal Highway Administration, Washington, DC by Westat, Rockville, Maryland. May, 2006
- [46] MCDONALD, L. et al. *Clearing our Path*. CNIB, Ontario division, 2009
- [47] MITANI, S., SUEDA, O. et al. *Measurement of Luminance Contrast Sensitivity of Persons with Low Visual Capability in order to Secure the Visibility of Tactile Walking Surface Indicators*. *Assistive Technology Research Series*, **20**, 2007, pp. 326–330, Japan
- [48] MITANI, S., TAUCHI, M. et al. *Study on Illuminance Dependency of Color Identification Characteristics for Persons with Low Visual Capacity*. *Assistive Technology Research Series*, **25**, 2009, pp. 468–472, Japan
- [49] MITANI, S., TAUCHI, M. et al. *Study on Background Illuminance and Color Conspicuity Characteristics for Persons with Low Visual Capacity*. *Assistive Technology Research Series*, **25**, 2009, pp. 473–477, Japan
- [50] MITANI, S., TAUCHI, M. et al. *Measurement of Visibility of TWSIs perceived by LVs*. *Assistive Technology Research Series*, **29**, 2011, pp.618 - 625, Japan
- [51] OXLEY, P.R. *Inclusive Mobility — A Guide to Best Practice on Access to Pedestrian and Transport Infrastructure*. Department of Transport UK. 2002. Available at <http://www.dft.gov.uk/transportforyou/access/peti/inclusivemobility>
- [52] PECK, A.F. and BENTZEN, B.L. *Tactile Warnings to Promote Safety in the Vicinity of Transit Platforms Edges*. US Department of Transportation, Federal Transit Administration, Volpe National Transportation Systems Centre. Cambridge, MA, USA. 1997. Available at <http://accessforblind.org/publications/USDOT/DOT-TSC-UMTA-87-11.pdf>
- [53] REBSTOCK, M., ALBERS, A., AURICH, T., et al, *Hinweise für barrierefreie Verkehrsanlagen*, (In German) FGSV Nr.212, 2011, Germany
- [54] SAPOLINSKI, J., GARTH, S.M. and GARTH, I.M. *An improved metric for luminance contrast using colour modified clinical eye charts*. Redeemer Baptist School, North Parramatta, Australia. Available at http://www.redeemer.nsw.edu.au/PDFs/Sapolinski_Scientific_Report.pdf
- [55] SAVILL, T., DAVIES, G. et al. *Trials on platform edge tactile surfaces*. 1997, UK. Available at www.trl.co.uk
- [56] SAVILL, T., GALLON, C., MCHARDY, G., *Delineation for cyclists and visually impaired pedestrians on segregated, shared routes*. 1997, UK. Available at www.trl.co.uk
- [57] SCHMIDT, E. *Leitlinienfest im Hauptbahnhof Zürich — Auswertung*. Schweizerische Fachstelle für behindertengerechtes Bauen in 1996. Zürich, Schweiz
- [58] STAHL, A., ALMÈN, M., & WEMME, M., *How do existing surfaces in the outdoor environment serve as lightness contrasts for visually impaired people?* Swedish Traffic Administration, 2010
- [59] STAHL, A., NEWMAN, E., DAHLIN-IWANOFF, et al, *Detection of warning surfaces in pedestrian environments: The importance for blind people of curb, depth, and structure of tactile surfaces*. *Disability and Rehabilitation*, 2010; 32(6): 469–482. Sweden
- [60] STAHL, A., ALMÈN, M., *How do blind people orient themselves along a continuous guidance route?* Swedish Road Administration, 2007
- [61] STAHL, A., ALMÈN, M. and WEMME, M. *Orientation using guidance surfaces — Blind tests of tactility in surfaces with different materials and structures*. Swedish Road Administration 2004:158E
- [62] TAKEDA, M., TAKAHASHI, R., TAUCHI, M. et al. *A study for directionality of bar shaped tactile walking surface indicator examined by vision impaired persons*. Research paper contributed to Ergonomics. Ver.9.7.2050916, Japan. May 2005

ISO 23599:2012(E)

ICS 11.180.30

Price based on 37 pages