

---

---

**Coal — Determination of bulk density  
for the use in charging of coke ovens**

*Charbon — Détermination de la masse volumique en vrac à des fins  
d'enfournement dans les fours à coke*





**COPYRIGHT PROTECTED DOCUMENT**

© ISO 2013

All rights reserved. Unless otherwise specified, no part of this publication may be reproduced or utilized otherwise in any form or by any means, electronic or mechanical, including photocopying, or posting on the internet or an intranet, without prior written permission. Permission can be requested from either ISO at the address below or ISO's member body in the country of the requester.

ISO copyright office  
Case postale 56 • CH-1211 Geneva 20  
Tel. + 41 22 749 01 11  
Fax + 41 22 749 09 47  
E-mail [copyright@iso.org](mailto:copyright@iso.org)  
Web [www.iso.org](http://www.iso.org)

Published in Switzerland

# Contents

	Page
Foreword .....	iv
Introduction .....	v
<b>1 Scope</b> .....	<b>1</b>
<b>2 Normatives references</b> .....	<b>1</b>
<b>3 Terms and definitions</b> .....	<b>1</b>
<b>4 Principle</b> .....	<b>1</b>
<b>5 Samples and apparatus</b> .....	<b>1</b>
5.1 General .....	1
5.2 Apparatus .....	2
<b>6 Sampling</b> .....	<b>2</b>
6.1 Test portion for bulk density .....	2
6.2 Test sample .....	2
<b>7 Procedure</b> .....	<b>2</b>
<b>8 Expression of results</b> .....	<b>4</b>
<b>9 Reporting of results</b> .....	<b>5</b>
<b>10 Precision</b> .....	<b>5</b>
10.1 Repeatability .....	5
10.2 Reproducibility .....	5
<b>11 Test report</b> .....	<b>5</b>
<b>Bibliography</b> .....	<b>6</b>

## Foreword

ISO (the International Organization for Standardization) is a worldwide federation of national standards bodies (ISO member bodies). The work of preparing International Standards is normally carried out through ISO technical committees. Each member body interested in a subject for which a technical committee has been established has the right to be represented on that committee. International organizations, governmental and non-governmental, in liaison with ISO, also take part in the work. ISO collaborates closely with the International Electrotechnical Commission (IEC) on all matters of electrotechnical standardization.

The procedures used to develop this document and those intended for its further maintenance are described in the ISO/IEC Directives, Part 1. In particular the different approval criteria needed for the different types of ISO documents should be noted. This document was drafted in accordance with the editorial rules of the ISO/IEC Directives, Part 2. [www.iso.org/directives](http://www.iso.org/directives)

Attention is drawn to the possibility that some of the elements of this document may be the subject of patent rights. ISO shall not be held responsible for identifying any or all such patent rights. Details of any patent rights identified during the development of the document will be in the Introduction and/or on the ISO list of patent declarations received. [www.iso.org/patents](http://www.iso.org/patents)

Any trade name used in this document is information given for the convenience of users and does not constitute an endorsement.

The committee responsible for this document is ISO/TC 27, *Solid mineral fuels*, Subcommittee SC 1, *Coal preparation: Terminology and performance*.

This second edition cancels and replaces the first edition (ISO 23499:2008), which has been technically revised.

This International Standard is based, with permission of ASTM International, on ASTM D291, *Standard Test Method for Cubic Foot Weight of Crushed Bituminous Coal*, copyright ASTM International.

## Introduction

The bulk density of coal is influenced by its physical characteristics, such as relative density, shape and size distribution of the coal particles, on the coal moisture content as well as on the dimensions of the measuring container. Since the results for coal bulk density change according to variations in the above factors, it is recommended that a separate size analysis and total moisture determination be made in accordance with ISO 1953 and ISO 589, respectively.

The present method describes a procedure for determining a reference bulk density for crushed coal such as that charged into coke ovens. When charging a coke oven, a knowledge of the mass of coal placed in the oven for maintaining a relatively constant oven charge is a requirement. This test is designed to obtain a degree of compaction of coal comparable to the densities attained in industrial coke ovens.

www.iso.org

# Coal — Determination of bulk density for the use in charging of coke ovens

## 1 Scope

This International Standard provides description of a cone procedure for determining an uncompacted bulk density of crushed coal less than 37 mm in size, such as is charged into coke ovens. It focuses on the uncompacted bulk density of coal resulting from flowing the material into a measuring container (box) in the absence of compacting forces.

This International Standard does not cover procedures for determining a compacted coal bulk density nor to the testing of fine or powdered coal (for boiler or utility application) nor to the determination of bulk density of coal in storage piles.

## 2 Normatives references

The following documents, in whole or in part, are normatively referenced in this document and are indispensable for its application. For dated references, only the edition cited applies. For undated references, the latest edition of the referenced document (including any amendments) applies.

ISO 589, *Hard coal — Determination of total moisture*

ISO 1213-1, *Solid mineral fuels — Vocabulary — Part 1: Terms relating to coal preparation*

ISO 1213-2, *Solid mineral fuels — Vocabulary — Part 2: Terms relating to sampling, testing and analysis*

ISO 1953, *Hard coal — Size analysis by sieving*

ISO 13909-4, *Hard coal and coke — Mechanical sampling — Part 4: Coal — Preparation of test samples*

## 3 Terms and definitions

For the purposes of this document, the terms and definitions given in ISO 1213-1 and ISO 1213-2 apply.

## 4 Principle

The bulk density is determined by filling a weighed container (measuring box) of known volume with coal and determining the increase in mass.

## 5 Samples and apparatus

### 5.1 General

Samples containing fines can show significant variations in bulk density with variations in moisture. Care should be taken to ensure that moisture in the test sample is representative of the portion for bulk density.

## 5.2 Apparatus

**5.2.1 Measuring box**, a cubical container of  $(0,028\ 4 \pm 0,000\ 082)$  m<sup>3</sup> (1 ft<sup>3</sup>) capacity and internal dimensions of 305 mm (1 ft), with a smooth inner surface, rigidly constructed and fitted with handles. The exact volume of the box, in cubic metres, shall be determined using water of a known density.

The container shall be constructed of metal of sufficient thickness to ensure the rigidity of the walls and the base of the container under the conditions of the test. (Minimum wall thickness of 3 mm is recommended.)

NOTE The internal dimensions of the cubical container can be “rounded off” to 300 mm with an acceptable tolerance, giving a volume of 0,027 m<sup>3</sup>. The most important criterion is to know the exact volume of the measuring box since it is critical for calculating the coal bulk density.

**5.2.2 Cone**, for filling the box, should conform to [Figure 1](#). The dimensions of this cone shall be as follows: 610 mm high with an inside diameter at the top of 510 mm and a circular opening of 115 mm in diameter at the bottom. A slide valve consisting of a slide-plate shutter and its supports shall be welded to the bottom of the cone in such a manner that the valve can be opened and closed with ease by removing or inserting the shutter in its supporting slides. The cone shall be supported in a tripod frame having a circular opening at the top of 460 mm in diameter. This frame shall support the cone so that the top side of the shutter shall be 560 mm from the inside bottom surface of the box (see [Figure 1](#)).

**5.2.3 Levelling bar**, a steel strip approximately 760 mm long by 40 mm wide and 5 mm thick.

**5.2.4 Weighing device**, a weighing platform capable of weighing up to 100 kg and sensitive to 0,05 kg.

## 6 Sampling

### 6.1 Test portion for bulk density

Crushed coal samples shall be collected in accordance with ISO 13909-4. During the collection of the test portion for bulk density, the increments of the sample shall be stored in an airtight container to prevent loss of moisture. The minimum mass of sample for bulk density shall be 150 kg, which is sufficient for four replicate determinations and the subsequent determination of total moisture.

### 6.2 Test sample

The test portion for bulk density shall be thoroughly mixed and subdivided, without crushing, into four 34 kg portions in accordance with ISO 13909-4. This operation shall be done as quickly as possible to avoid loss of moisture, and the bulk density shall be determined immediately. If the determination cannot be made immediately, the samples shall be kept in air-tight containers and waterproof with minimum airspace and with tightly fitting covers until the time for making the determination.

## 7 Procedure

**7.1** Before filling the cone hopper with coal, level its tripod on a metal plate or solid floor. Pour the prepared sample into a pile on the floor and carefully flatten it using a shovel or scoop to about 100 mm in thickness. Avoid putting undue pressure on the coal with the back of the shovel or scoop. Take successive shovelfuls or scoopfuls from uniformly distributed points in the pile and allow them to slide gently from the shovel or scoop into the hopper at different peripheral points. This prevents segregation and packing while the hopper is being filled. Place about 34 kg of coal in the hopper.

**7.2** Centre the previously weighed measuring box under the valve of the cone. Then remove the valve shutter completely, allowing all of the coal to flow into the box and overflow the edges. Loosen wet coal



not flowing freely from the hopper by gently thrusting downward through the coal to the valve with the levelling bar.

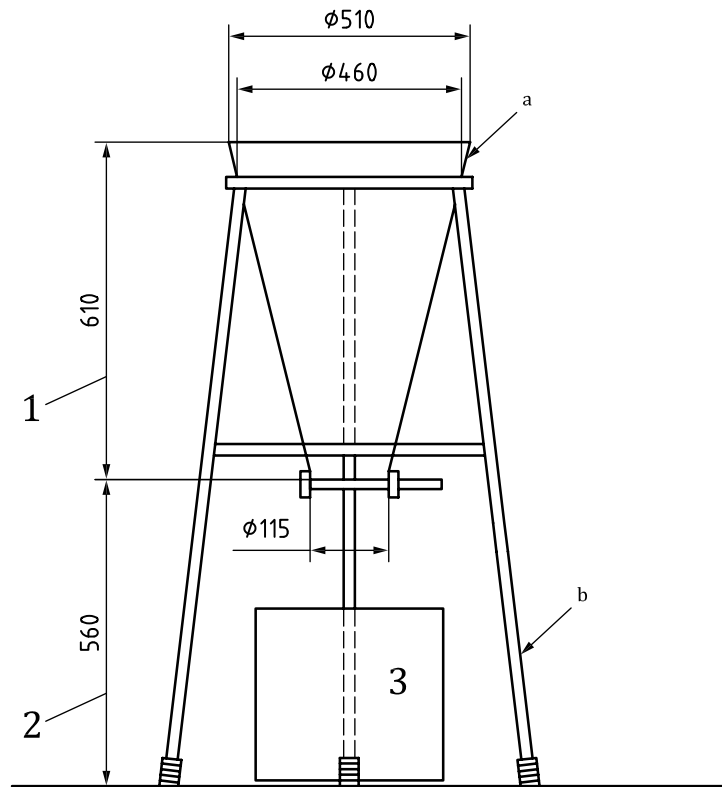
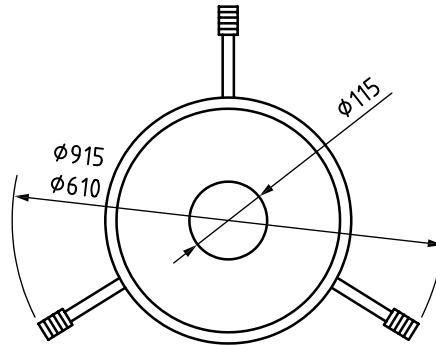

a) Complete apparatus

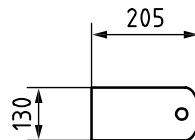

b) Iron shutter to fit the base of the hopper

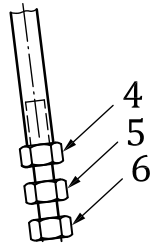

c) Detail of adjustable hopper leg

**Key**

- 1 cone height
- 2 height from iron shutter to internal base of measuring box
- 3 measuring box
- 4 nut
- 5 lock nut
- 6 M16 bolt
- a 1,6 mm steel
- b DN18 pipe

**Figure 1 — Apparatus for cone procedure**

**7.3** After filling the box, carefully level off the excess coal above the box edge by means of the levelling bar, ensuring at the same time that all the corners of the box are filled. Avoid jarring or shifting the filled box until all the excess coal is levelled off. Place the measuring box on the platform scale and weigh it to the nearest 0,05 kg. Record the difference in mass between the filled and the empty box to the nearest 0,05 kg as the uncompacted mass of coal.

Aside from the character of the coal itself, moisture content and size distribution of the coal are the two main factors that affect its bulk density. The result of the moisture determination shall be included in the test report. It is also necessary that a sieve analysis of the coal be reported along with the bulk density for proper interpretation of the bulk density. See ISO 589 for details of the moisture determination and ISO 1953 for details of the size analysis by sieving.

## 8 Expression of results

The bulk density,  $\rho_{B,dB}$ , of the coal, expressed in kilograms per cubic metre, on a dry basis, is given by Formula (1):

$$\rho_{B,dB} = \frac{(m_1 - m_0)}{V} \times \frac{(100 - M)}{100} \quad (1)$$

where

$m_0$  is the mass of the clean, dry measuring box, expressed in kilograms;

$m_1$  is the mass of the filled measuring box, expressed in kilograms;

$V$  is the volume of the clean, dry measuring box, expressed in cubic metres;

$M$  is the total moisture of the coal, expressed as a percentage by mass, determined in accordance with ISO 589.

The bulk density,  $\rho_{B,ar}$ , of the coal, expressed in kilograms per cubic metre, on an “as received” basis, is given by Formula (2):

$$\rho_{B,ar} = \frac{(m_1 - m_0)}{V} \quad (2)$$

where the symbols are the same as for Formula (1).

## 9 Reporting of results

Each result shall be expressed in kilograms per cubic metre to one decimal place.

The reported mean value shall be the mean of duplicate determinations, and shall be given to the nearest whole number.

## 10 Precision

### 10.1 Repeatability

The results of duplicate determinations, carried out in the same laboratory by the same operator with the same apparatus on representative portions taken from the same test sample, should not differ by more than 10,0 kg/m<sup>3</sup>.

When two results are obtained that differ by more than this value, two additional tests shall be made. If the second pair of results meets the repeatability requirements, the first pair shall be discarded and the mean of the second pair shall be reported.

When both pairs of results exceed the repeatability, the mean of the four results shall be reported, provided that the two most divergent results differ by less than 13,0 kg/m<sup>3</sup>. Otherwise, all results shall be discarded and the apparatus, procedure, and sample shall be examined for causes of non-compliance, which shall be corrected before re-determining new pairs of values.

### 10.2 Reproducibility

No value for reproducibility can be quoted for determinations carried out in different laboratories because the transport of bulk coal samples involves the risk of breakage and, thus, alteration of the size distribution and the bulk density.

## 11 Test report

The test report shall include the following:

- a) reference to this International Standard;
- b) identification of the sampled tested;
- c) results and the moisture basis, e.g.  $\rho_{B,db}$  and  $\rho_{B,ar}$  ;
- d) moisture content and size distribution of the sample.

## Bibliography

- [1] ASTM D291, *Standard Test Method for Cubic Foot Weight of Crushed Bituminous Coal*

.....

11/29/2013 02:04:53 MST

