**Rubber, vulcanized or thermoplastic —
Determination of resistance to abrasion
using a driven, vertical abrasive disc**

*Caoutchouc, vulcanisé ou thermoplastique — Détermination de la
résistance à l'abrasion au moyen d'un disque abrasif vertical, motorisé*



Reference number
ISO 23233:2009(E)

© ISO 2009

PDF disclaimer

This PDF file may contain embedded typefaces. In accordance with Adobe's licensing policy, this file may be printed or viewed but shall not be edited unless the typefaces which are embedded are licensed to and installed on the computer performing the editing. In downloading this file, parties accept therein the responsibility of not infringing Adobe's licensing policy. The ISO Central Secretariat accepts no liability in this area.

Adobe is a trademark of Adobe Systems Incorporated.

Details of the software products used to create this PDF file can be found in the General Info relative to the file; the PDF-creation parameters were optimized for printing. Every care has been taken to ensure that the file is suitable for use by ISO member bodies. In the unlikely event that a problem relating to it is found, please inform the Central Secretariat at the address given below.



COPYRIGHT PROTECTED DOCUMENT

© ISO 2009

All rights reserved. Unless otherwise specified, no part of this publication may be reproduced or utilized in any form or by any means, electronic or mechanical, including photocopying and microfilm, without permission in writing from either ISO at the address below or ISO's member body in the country of the requester.

ISO copyright office
Case postale 56 • CH-1211 Geneva 20
Tel. + 41 22 749 01 11
Fax + 41 22 749 09 47
E-mail copyright@iso.org
Web www.iso.org

Published in Switzerland

Contents

Page

Foreword.....	iv
1 Scope	1
2 Normative references	1
3 Terms and definitions	2
4 Principle	2
5 Apparatus	3
5.1 Abrasion test machine	3
5.2 Balance	5
6 Test pieces	5
6.1 Type and preparation	5
6.2 Number	5
6.3 Time interval between vulcanization or forming and testing	5
7 Conditioning	6
8 Test temperature	6
9 Test conditions	6
9.1 Preliminary abrasion	6
9.2 Run-in	6
9.3 Test conditions	7
10 Procedure	8
10.1 Order of the test pieces	8
10.2 Marking of the test pieces	8
10.3 Abrasion testing	8
11 Expression of results ^[1] to ^[5]	9
12 Test report	9
Bibliography	11

Foreword

ISO (the International Organization for Standardization) is a worldwide federation of national standards bodies (ISO member bodies). The work of preparing International Standards is normally carried out through ISO technical committees. Each member body interested in a subject for which a technical committee has been established has the right to be represented on that committee. International organizations, governmental and non-governmental, in liaison with ISO, also take part in the work. ISO collaborates closely with the International Electrotechnical Commission (IEC) on all matters of electrotechnical standardization.

International Standards are drafted in accordance with the rules given in the ISO/IEC Directives, Part 2.

The main task of technical committees is to prepare International Standards. Draft International Standards adopted by the technical committees are circulated to the member bodies for voting. Publication as an International Standard requires approval by at least 75 % of the member bodies casting a vote.

Attention is drawn to the possibility that some of the elements of this document may be the subject of patent rights. ISO shall not be held responsible for identifying any or all such patent rights.

ISO 23233 was prepared by Technical Committee ISO/TC 45, *Rubber and rubber products*, Subcommittee SC 2, *Testing and analysis*.

Rubber, vulcanized or thermoplastic — Determination of resistance to abrasion using a driven, vertical abrasive disc

WARNING — Persons using this International Standard should be familiar with normal laboratory practice. This standard does not purport to address all of the safety problems, if any, associated with its use. It is the responsibility of the user to establish appropriate safety and health practices and to ensure compliance with any national regulatory conditions.

CAUTION — Certain procedures specified in this International Standard may involve the use or generation of substances, or the generation of waste, that could constitute a local environmental hazard. Reference should be made to appropriate documentation on safe handling and disposal after use.

1 Scope

This International Standard specifies a method for the determination of the resistance of rubber to abrasion using a driven, vertical abrasive disc (the LAT 100: Laboratory Abrasion Tester 100).

The loss in mass on abrasion is determined through the slip caused by setting different slip angles and rotational speeds between a wheel-shaped rubber test piece and an abrasive disc which are rotating in planes at right angles to each other and pressed against each other with a specified load. The test result can be reported as the loss in mass per unit running distance and/or as an abrasion resistance index compared to a reference compound.

This International Standard is applicable to comparative testing, quality control, specification compliance testing, referee testing and research and development work.

As the test device described is capable of setting each abrasion parameter, such as slip angle, rotational speed of the abrasive disc and load, independently, the method is suitable for carrying out a wide range of abrasion tests for various rubber products, especially tyres.

2 Normative references

The following referenced documents are indispensable for the application of this document. For dated references, only the edition cited applies. For undated references, the latest edition of the referenced document (including any amendments) applies.

ISO 525:1999, *Bonded abrasive products — General requirements*

ISO 8486-1:1996, *Bonded abrasives — Determination and designation of grain size distribution — Part 1: Macrogrits F4 to F220*

ISO 23529, *Rubber — General procedures for preparing and conditioning test pieces for physical test methods*

3 Terms and definitions

For the purposes of this document, the following terms and definitions apply.

3.1

abrasion

loss of material from a surface due to frictional forces

[ISO 23794:2003]

3.2

abrasion resistance

resistance to wear resulting from mechanical action upon a surface

[ISO 23794:2003]

NOTE Abrasion resistance can be expressed as a loss in mass or an abrasion resistance index.

3.3

abrasion resistance index

ratio of the loss in volume of a reference compound to the loss in volume of a test rubber measured under the same specified conditions and expressed as a percentage

[ISO 23794:2003]

NOTE The smaller the number, the lower the abrasion resistance.

3.4

slip angle

angle made by the plane of the test piece with the radius of the abrasive disc which passes through the point of contact between the test piece and the abrasive disc

3.5

running distance

total distance travelled by a point on the circumference of the test piece relative to the abrasive disc

3.6

reference compound

compound of known abrasion resistance which is compared with that of the test rubber

4 Principle

A wheel-shaped test piece and an abrasive disc are pressed against each other at right angles by a specified load. The abrasive disc is driven so that it rotates, causing the test piece to rotate with it. Wear occurs due to slip between the test piece and the abrasive disc.

Different angles of slip between the abrasive disc and the test piece can be used to give different speeds of rotation of the test piece.

A powder consisting of a mixture of MgO and Al₂O₃ is used to prevent smearing of the test piece and the surface of the abrasive disc.

The loss in mass of the test piece is measured and the loss per unit running distance calculated. The abrasion resistance index can also be determined by comparing the loss in mass of the test piece per unit running distance with the loss in mass per unit running distance of a reference compound tested under the same conditions.

5 Apparatus

5.1 Abrasion test machine

The abrasion test machine (see Figure 1) consists of an abrasive electro-corundum disc, a test piece holder with test piece mounting facilities (see Figure 2), a feed device for anti-smearing powder, an infrared thermometer, a load application device, a slip angle adjustment device and a side force measurement device.

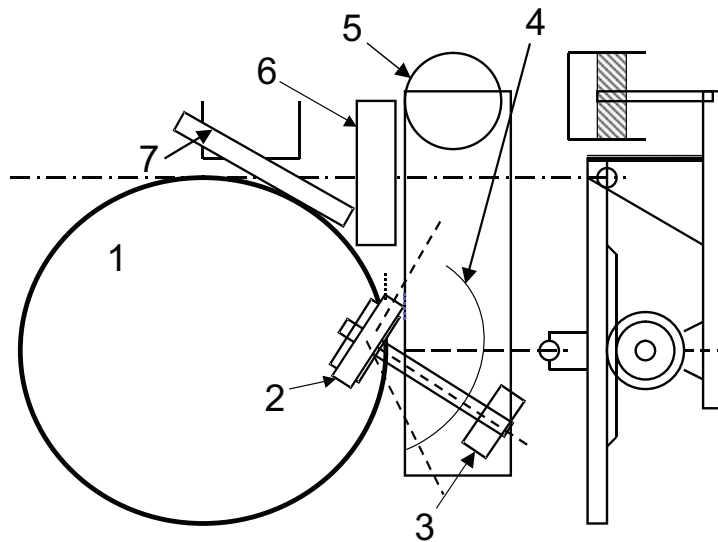

Key

- | | | | |
|---|--------------------------------------|---|---------------------------|
| 1 | electro-corundum disc | 5 | load application device |
| 2 | test piece | 6 | infrared thermometer |
| 3 | side force measurement device | 7 | anti-smearing powder feed |
| 4 | slip angle adjustable from 0° to 20° | | |

Figure 1 — Schematic illustration of the apparatus

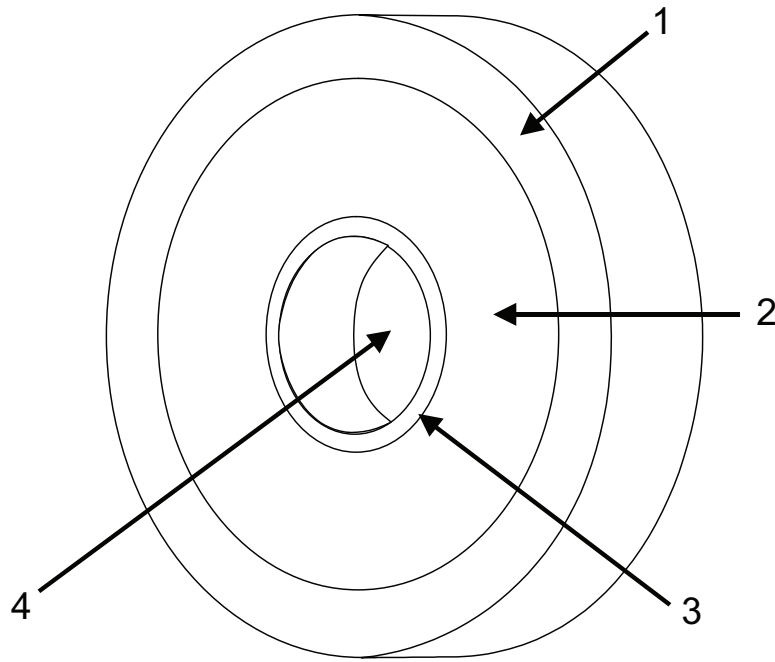

Key

- 1 test piece (external diameter: see Table 2, internal diameter: 35 mm)
- 2 steel support discs, one on each side (external diameter: 60 mm, internal diameter: 35 mm)
- 3 sleeve (external diameter: 35 mm, internal diameter: 30 mm)
- 4 bore for mounting shaft (diameter: 30 mm)

Figure 2 — Test piece mounted on the test piece holder

The test piece shall be mounted in such a way that it does not slip on its mounting shaft when the abrasive disc is rotated, so that the rotation of the abrasive disc is accurately transmitted to the test piece. A pair of 60 mm diameter support discs with a 35 mm bore at the centre shall be fitted on each side of the test piece to ensure the lateral rigidity of the test piece core (see Figure 2). Furthermore, a sleeve having an internal diameter of 30 mm, an external diameter of 35 mm and a length of 15 mm shall be inserted into the bore of the test piece to fix it securely on the mounting shaft.

The abrasive disc shall be mounted in such a way that it does not slip on the mounting shaft when torque is applied, so that the rotation of the shaft is accurately transmitted to the disc. The specifications of the abrasive disc shall be based on ISO 525:1999: abrasive A (in this case electro-corundum), grit size 60 (equivalent to the designation F60 specified in ISO 8486-1:1996), hardness grade I, nature of bond V (vitrified bond) and structure 8 (very open). The diameter of the abrasive disc shall be 350 mm and its thickness 25 mm.

The drive mechanism for the abrasive disc shall have a motor capable of controlling the circumferential speed of the disc in the range from 2,0 km/h to 30,0 km/h.

The apparatus shall be fitted with a loading mechanism to press the test piece against the abrasive disc with a force of 75 N during the test, regardless of the combination of disc speed and slip angle. The slip angle setting shall be variable in the range from 0° to 20°.

The apparatus shall also be fitted with a feed mechanism to drop anti-smearing powder at a specified rate into the area of contact between the test piece and the abrasive disc. The feed rate shall be adjustable over the range between 0 units and 100 units, corresponding to 0 g/min to 75 g/min on a non-linear scale (see Table 1). The anti-smearing powder shall consist of a mixture of 2 parts by volume of Al₂O₃ (electro-corundum, grain size 120) and 1 part by volume of MgO (heavy, bulk density ≈ 675 g/l, type 90, grain size 120).

Table 1 — Anti-smearing powder feed rate

Feed rate in units	Feed rate in g/min
1	0,07
2	0,13
5	0,37
10	0,96
15	1,66
20	2,31
40	10,76
60	34,65
80	55,61
100	75,17

NOTE The powder feed rate used during the test is chosen to ensure that the surfaces of the abrasive disc and the test piece are cleaned efficiently (see Table 3).

5.2 Balance

The balance used shall be of sufficient accuracy to enable the loss in mass of the test piece to be determined to within $\pm 0,1$ mg.

6 Test pieces

6.1 Type and preparation

Test pieces shall be in the form of a disc having the dimensions shown in Table 2. They shall be prepared by moulding or by cutting from a finished product, which may be either vulcanized or thermoplastic, using a rotary cutter. The abrasion surface of test pieces shall be smooth, without any pattern.

Table 2 — Dimensions of test piece

Type of test piece	Inner diameter mm	Outer diameter mm	Thickness mm
Type A	35	84	20
Type B	35	80	20

6.2 Number

One test piece shall be used for each compound tested, but the reference material shall be tested in duplicate.

6.3 Time interval between vulcanization or forming and testing

The time interval between vulcanization or forming and testing shall be in accordance with ISO 23529.

7 Conditioning

The test pieces shall be conditioned in accordance with ISO 23529.

8 Test temperature

The test shall be carried out at a standard laboratory temperature (see ISO 23529).

During a test run, there may be a considerable increase in temperature at the abrasion interface, which may lead to a temperature rise within the test piece. For the purposes of this International Standard, such temperature rises shall be disregarded, the test temperature being that of the ambient atmosphere and of the test piece before commencing the test.

9 Test conditions

9.1 Preliminary abrasion

All test pieces shall be subjected to a preliminary abrasion procedure to remove the skin from the rubber and any impurities on the surface. The preliminary abrasion procedure shall be carried out using the same type of abrasive disc as used for the abrasion test (see 5.1). The following conditions are recommended:

load	75 N;
slip angle	13°;
speed of abrasive disc	25 km/h;
anti-smearing powder feed rate	30 units;
running distance	500 m right and 500 m left.

9.2 Run-in

All test pieces shall be run in before the actual measurements start. The run-in shall be carried out in both rotational directions and using the same type of abrasive disc as used for the abrasion tests (see 5.1). The following conditions are recommended:

load	75 N
slip angle	13°
speed of abrasive disc	25 km/h
anti-smearing powder feed rate	80 units
running distance	500 m right and 500 m left

NOTE The powder feed rate depends not only on the settings of the machine (slip angle, load and speed of abrasive disc) but also on the compound under test. For example, natural rubber and highly oil-extended emulsion SBR compounds need a higher feed rate than more recent compounds using rubbers such as solution SBR and BR.

After the run-in, each test piece shall be weighed and its mass recorded. This mass shall be used as the initial mass in the abrasion test proper.

If the test programme takes longer than one day, those test pieces which it was not possible to test on the first day shall be run in again and reweighed at the beginning of the next test day.

9.3 Test conditions

With each test piece, 18 abrasion runs shall be carried out using the test conditions specified in Table 3. Each abrasion run shall be carried out first in one direction of rotation and then in the other. This abrasion sequence is designed to minimize the influence of the normal wear and tear of the abrasive disc on the test.

Table 3 — Test conditions for each abrasion run

Abrasion run	Load N	Slip angle degrees	Rotational speed km/h	Distance run m	Powder feed rate units	
					Abrasion resistance	
					high	low
1	75	16	25	250	40	80
2	75	16	9	140	15	30
3	75	13	2,5	200	11	22
4	75	9	25	600	11	22
5	75	9	9	600	8	16
6	75	9	2,5	600	2	4
7	75	5,5	25	2 500	4	8
8	75	5,5	9	1 500	3	6
9	75	5,5	2,5	1 500	2	4
10	75	5,5	2,5	1 500	2	4
11	75	5,5	9	1 500	3	6
12	75	5,5	25	2 500	4	8
13	75	9	2,5	600	2	4
14	75	9	9	600	8	16
15	75	9	25	600	11	22
16	75	13	2,5	200	11	22
17	75	16	9	140	15	30
18	75	16	25	250	40	80

If necessary, the testing of a particular compound can be repeated with a different powder feed rate. For instance, if the surface seems to be sticky at the end of the test, the powder feed rate can be raised and the test repeated. Stickiness of the test piece surface causes reduced abrasion loss and this may lead to the false conclusion that the abrasion resistance is high. If the surface looks extremely white, too much powder has been applied. Ideally, the surface should be only slightly white. Too high a powder feed rate leads to similar results as with too low a powder feed rate, but is less critical.

In this context, it is important to understand the difference between “high” and “low” abrasion resistance. Typical high abrasion resistance compounds are solution SBR summer-tread tyres; specific low abrasion resistance compounds are very soft NR winter-tread tyres.

When determining the abrasion resistance index, the same 18 abrasion runs shall be carried out with the reference compound test pieces as with the compounds being investigated.

10 Procedure

10.1 Order of the test pieces

The test programme shall be carried out in the following order:

- reference compound test piece 1;
- test piece for compound 1;
- test piece for compound 2;
- test piece for compound 3;
- test piece for compound n ;
- reference compound test piece 2.

10.2 Marking of the test pieces

Each test piece shall be numbered on one face. This marking is intended to enable the direction of rotation to be identified during the test. For example, if the numbered face of the test piece is on the left as seen by the operator, the direction of rotation is anti-clockwise and if it is on the right the direction of rotation is clockwise.

10.3 Abrasion testing

Carry out testing as follows:

- a) weigh each test piece to the nearest 0,1 mg after the run-in;
- b) carry out abrasion run 1 with each test piece, under the conditions given in Table 3, first in one direction of rotation and then in the other, reweighing each test piece to the nearest 0,1 mg on completion of the run;
- c) carry out abrasion run 2 with each test piece, under the conditions given in Table 3, in the same way, again reweighing each test piece to the nearest 0,1 mg on completion of the run;
- d) continue the sequence of abrasion runs specified in Table 3, weighing each test piece to the nearest 0,1 mg after each run, until all 18 runs have been completed with each test piece.

Before all weighings, remove any abrasion residues, anti-smearing powder or electro-corundum particles from the surface of the test piece.

For practical reasons, it is preferable to limit the number of different test pieces in any one test programme. Abrasion tests take time, and the more test pieces there are, the longer the programme will be and the longer the rest periods for the test pieces in between runs will be. Four to six test pieces per test programme are easy to manage, but it is difficult to handle more than eight test pieces.

11 Expression of results [1] to [5]

Calculate, for each abrasion run carried out on each test piece, the loss in mass per unit running distance, using Equation (1):

$$A = \frac{m}{s} \quad (1)$$

where

A is the loss in mass per unit running distance during the run, in mg/km;

m is the loss in mass during the run, in mg;

s is the running distance, in km.

Then calculate the average value of A for each test piece, using Equation (2):

$$\bar{A} = \frac{\sum_{m=1}^{m=18} A_m}{18} \quad (2)$$

where

\bar{A} is the average value of A for all the abrasion runs, in mg/km;

A_m is the value of A calculated for abrasion run m , in mg/km;

18 is the number of abrasion runs.

These average results may also be used to calculate the abrasion resistance index, using Equation (3):

$$I_A = \frac{\bar{A}_R}{\bar{A}_C} \times 100 \quad (3)$$

where

I_A is the abrasion resistance index, in per cent;

\bar{A}_R is the average value of the loss in mass per unit running distance for the two reference test pieces (taken together), in mg/km;

\bar{A}_C is the average value of the loss in mass per unit running distance for the compound in question, in mg/km.

12 Test report

The test report shall include the following information:

a) sample details:

- 1) a full description of the sample and its origin,
- 2) the method of preparation of the test pieces, e.g. by moulding or by cutting from the sample;

ISO 23233:2009(E)

- b) the test method used, i.e. the number of this International Standard;
- c) test details:
 - 1) the type of test piece used (see Table 2),
 - 2) the test temperature (see Clause 8),
 - 3) the values of the test machine variables, including load, slip angle and anti-smearing powder flow rate,
 - 4) details of any procedures not specified in this International Standard;
- d) test results: for each compound tested, give the loss in mass per unit running distance for each abrasion run, the average loss in mass per unit running distance and, if calculated, the abrasion resistance index;
- e) the date(s) of testing.

Bibliography

- [1] SCHALLAMACH, A., and TURNER, D.M.: *Wear*, **3** (1960), p. 1
- [2] GROSCH, K.A., and SCHALLAMACH, A.: *Wear*, **4** (1961), p. 356
- [3] GROSCH, K.A., *J. IRI*, **1** (1967), p. 35
- [4] GROSCH, K.A., and SCHALLAMACH, A.: *Trans. Instn. Rubber Ind.*, **41** (1965), p. T 80
- [5] SCHALLAMACH, A.: *Rubber Chem. Techn.*, **41** (1968), p. 209
- [6] HEINZ M.: *Eine Laborabriebmethode im Einsatz zur Entwicklung von Füllstoffsystemen*, German Rubber Conference 2000, Nuremberg
- [7] HEINZ M.: *Eine Laborabriebmethode zur Voraussage des Straßenabriebs von PKW-Reifen*, 2nd Rubber Symposium of the Countries on the Danube, 2001.04.26 to 2001.04.28, Budapest, Hungary
- [8] HEINZ M.: *A test method to predict wear resistance of tire tread compounds in laboratory practice*, Tire Technology, 20.-22.02.2002, Hamburg, Germany
- [9] GROSCH, K.A., MONEYPENNY, H., and WALLACE, I.: *Correlation between Truck Tire Road Wear Performance and a System of Laboratory Abrasion Test*, IRC 2001, Birmingham
- [10] MONEYPENNY, H.: *Correlation between Truck Tire Tread Wear and Cut Growth Characteristics*, IRC 2000, Helsinki
- [11] ISO 23794:2003, *Rubber, vulcanized or thermoplastic — Abrasion testing — Guidance*

ICS 83.060

Price based on 11 pages