

INTERNATIONAL  
STANDARD

ISO  
23205

Second edition  
2014-12-15

---

---

**Agricultural tractors — Instructional  
seat**

*Tracteurs agricoles — Siège de convoyeur*



Reference number  
ISO 23205:2014(E)



**COPYRIGHT PROTECTED DOCUMENT**

© ISO 2014

All rights reserved. Unless otherwise specified, no part of this publication may be reproduced or utilized otherwise in any form or by any means, electronic or mechanical, including photocopying, or posting on the internet or an intranet, without prior written permission. Permission can be requested from either ISO at the address below or ISO's member body in the country of the requester.

ISO copyright office  
Case postale 56 • CH-1211 Geneva 20  
Tel. + 41 22 749 01 11  
Fax + 41 22 749 09 47  
E-mail [copyright@iso.org](mailto:copyright@iso.org)  
Web [www.iso.org](http://www.iso.org)

Published in Switzerland

# Contents

Page

<b>Foreword</b> .....	<b>iv</b>
<b>Introduction</b> .....	<b>v</b>
<b>1 Scope</b> .....	<b>1</b>
<b>2 Normative references</b> .....	<b>1</b>
<b>3 Terms and definitions</b> .....	<b>1</b>
<b>4 Requirements</b> .....	<b>1</b>

## Foreword

ISO (the International Organization for Standardization) is a worldwide federation of national standards bodies (ISO member bodies). The work of preparing International Standards is normally carried out through ISO technical committees. Each member body interested in a subject for which a technical committee has been established has the right to be represented on that committee. International organizations, governmental and non-governmental, in liaison with ISO, also take part in the work. ISO collaborates closely with the International Electrotechnical Commission (IEC) on all matters of electrotechnical standardization.

The procedures used to develop this document and those intended for its further maintenance are described in the ISO/IEC Directives, Part 1. In particular the different approval criteria needed for the different types of ISO documents should be noted. This document was drafted in accordance with the editorial rules of the ISO/IEC Directives, Part 2 (see [www.iso.org/directives](http://www.iso.org/directives)).

Attention is drawn to the possibility that some of the elements of this document may be the subject of patent rights. ISO shall not be held responsible for identifying any or all such patent rights. Details of any patent rights identified during the development of the document will be in the Introduction and/or on the ISO list of patent declarations received (see [www.iso.org/patents](http://www.iso.org/patents)).

Any trade name used in this document is information given for the convenience of users and does not constitute an endorsement.

For an explanation on the meaning of ISO specific terms and expressions related to conformity assessment, as well as information about ISO's adherence to the WTO principles in the Technical Barriers to Trade (TBT) see the following URL: [Foreword - Supplementary information](#)

The committee responsible for this document is ISO/TC 23, *Tractors and machinery for agriculture and forestry*, Subcommittee SC 4, *Tractors*.

This second edition cancels and replaces the first edition (ISO 23205:2006), of which has been technically revised.

## Introduction

This International Standard is intended to guide the manufacturer who wishes to supply an instructional seat and restraint inside the enclosed cab of an agricultural tractor. Nevertheless, many types of agricultural tractors will not be able to accommodate this feature.

This International Standard is recognition that an instructional seat for a trainer or trainee or service person on an agricultural tractor can be useful when providing training or instruction, or to enable a second person to aid in problem diagnosis.

Agricultural tractors equipped with ROPS (rollover protective structure) cabs large enough to accommodate two persons — one seated in the operator's seat with restraint and the other, a trainer, trainee or service person, seated in the instructional seat with restraint — provide greater safety for both persons in a rollover than would be available without an instructional seat.

© ISO 2014. All rights reserved.

.....

# Agricultural tractors — Instructional seat

## 1 Scope

This International Standard specifies the minimum design and performance requirements for an instructional seat and restraint designed for limited use by a trainer or trainee or service person inside an enclosed cab of an agricultural tractor.

The instructional seat is neither intended for, nor is it designed for use by, children.

## 2 Normative references

The following documents, in whole or in part, are normatively referenced in this document and are indispensable for its application. For dated references, only the edition cited applies. For undated references, the latest edition of the referenced document (including any amendments) applies.

ISO 3776-1, *Tractors and machinery for agriculture — Seat belts — Part 1: Anchorage location requirements*

ISO 3776-2, *Tractors and machinery for agriculture — Seat belts — Part 2: Anchorage strength requirements*

ISO 3776-3, *Tractors and machinery for agriculture — Seat belts — Part 3: Requirements for assemblies*

ISO 5353:1995, *Earth-moving machinery, and tractors and machinery for agriculture and forestry — Seat index point*

## 3 Terms and definitions

For the purposes of this document, the following terms and definitions apply.

### 3.1

#### **instructional seat**

area of sufficient size and shape, and having an integral or separate backrest, to allow a trainer, trainee or service person to be seated

### 3.2

#### **enclosed cab**

operator enclosure, including glazing materials in the windows, door(s) and of the windshield, mounted on the frame of an agricultural tractor

## 4 Requirements

**4.1** The instructional seat shall only be fitted on agricultural tractors equipped with an enclosed cab.

**4.2** The instructional seat and surrounding clearance zone shall have envelope dimensions in accordance with [Figure 1](#). The vertical clearance shall be of at least 830 mm above the seat index point. However, where a tractor satisfies the requirements relating to the driver's protection and seating, but its construction does not allow for such a vertical clearance for the passenger, the clearance may be reduced to 710 mm, provided that adequate padding, when deflected, that allows 830 mm vertical clearance immediately above the passenger seat at the level of the roof.

**4.3** The instructional seat shall be located as shown in [Figure 1](#). The instructional seat shall be placed such that the trainer, trainee or service person seated in it has a minimal potential impact on operation

and visibility, in keeping with intended use, and consistent with machine function and other design considerations.

**4.4** The instructional seat may or may not be padded or cushioned. Its backrest shall also have minimum dimensions according to [Figure 1](#). A non-glazed component at the rear or side of the enclosed cab, or a cab wall, may be used as the backrest, provided the dimensional requirements are met. The backrest may or may not be padded or cushioned.

**4.5** At least one handgrip or handrail of a minimum length of 150 mm shall be provided in a conveniently located position for use by the trainer, trainee or service person while seated in the instructional seat.

**4.6** A suitable area shall be provided for the lower extremities of the trainer, trainee or service person seated in the instructional seat such that there is no interference with the operator.

**4.7** A restraint system shall be provided. The restraint system shall be in accordance with ISO 3776-1, ISO 3776-2 and ISO 3776-3 or other applicable standards.

**4.8** The instructional seat, with the trainer, trainee or service person seated in it, shall be inside the enclosed cab structure.

**4.9** A safety sign indicating the required use of the seat belt shall be provided and positioned so as to be in view of the person seated in the instructional seat.

**4.10** The following information, at a minimum, shall be provided in the operator's manual:

- appropriate use of the instructional seat, i.e. by a trainer, trainee or service person;
- inappropriate use of the instructional seat, i.e. by children or other passengers;
- requirements to wear the seat belt;
- hazards identified with instructional seat use, such as falling from the machine and obstruction of the operator's view.



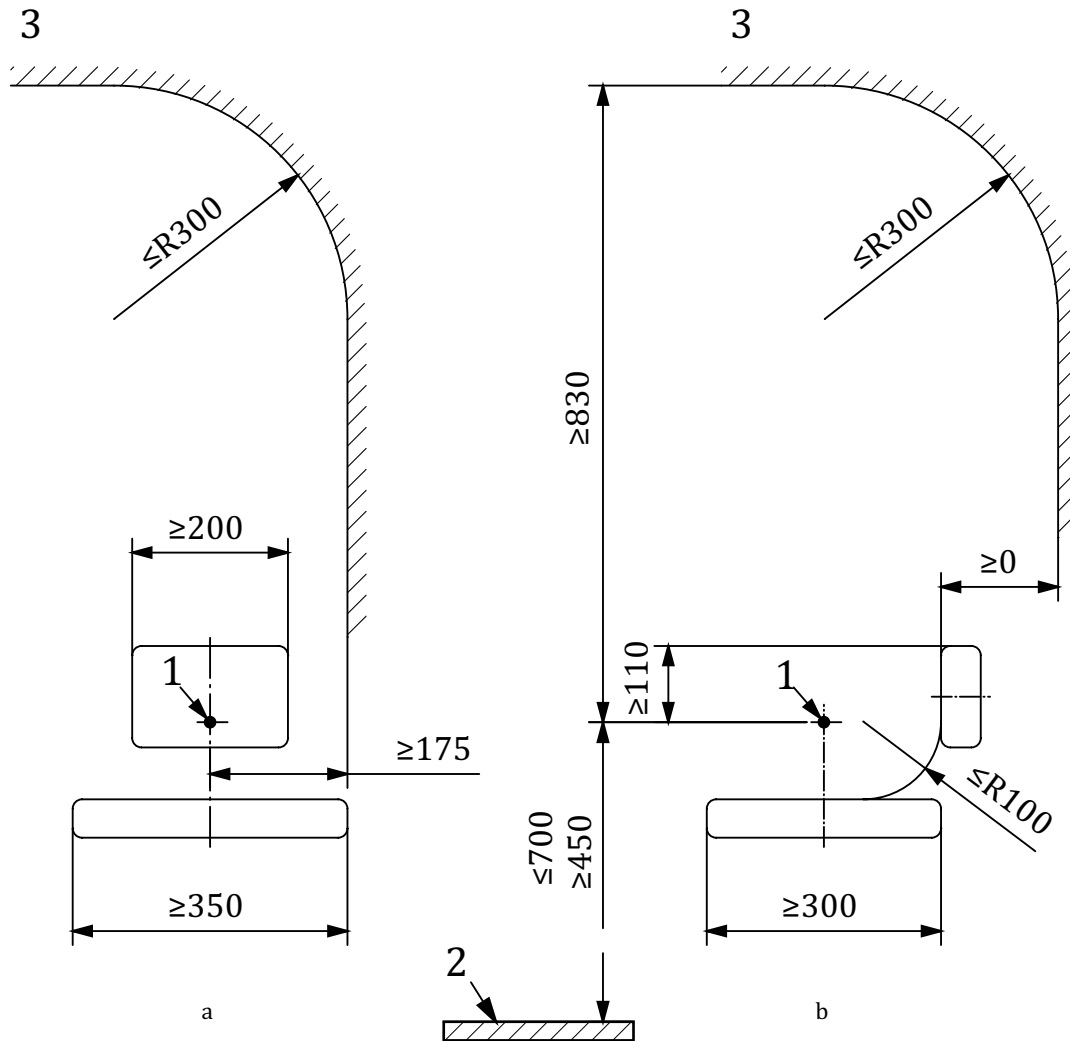

**Key**

- 1 seat index point (SIP)
- 2 foot rest
- 3 clearance zone
- a Front view.
- b Side view.

NOTE The SIP shall be determined in accordance with ISO 5353.

**Figure 1 — Envelope and seat dimensions**

---

---

**ICS 65.060.10**

Price based on 3 pages

012015 13:36:29 MST