

---

---

**Solar energy — Collector components  
and materials —**

Part 1:  
**Evacuated tubes — Durability and  
performance**

*Énergie solaire — Composants et matériaux du collecteur —  
Partie 1: Tubes sous vide — Durabilité et performance*



**COPYRIGHT PROTECTED DOCUMENT**

© ISO 2016, Published in Switzerland

All rights reserved. Unless otherwise specified, no part of this publication may be reproduced or utilized otherwise in any form or by any means, electronic or mechanical, including photocopying, or posting on the internet or an intranet, without prior written permission. Permission can be requested from either ISO at the address below or ISO's member body in the country of the requester.

ISO copyright office  
Ch. de Blandonnet 8 • CP 401  
CH-1214 Vernier, Geneva, Switzerland  
Tel. +41 22 749 01 11  
Fax +41 22 749 09 47  
copyright@iso.org  
www.iso.org

# Contents

Page

<b>Foreword</b> .....	<b>v</b>
<b>Introduction</b> .....	<b>vi</b>
<b>1 Scope</b> .....	<b>1</b>
<b>2 Normative references</b> .....	<b>1</b>
<b>3 Terms and definitions</b> .....	<b>1</b>
<b>4 Classification and test list</b> .....	<b>2</b>
<b>5 Testing of material</b> .....	<b>3</b>
5.1 Inspection for stones and knots.....	3
5.1.1 General.....	3
5.1.2 Test conditions.....	3
5.1.3 Apparatus.....	3
5.1.4 Procedure.....	3
5.1.5 Results.....	4
5.2 Inspection for scratches.....	4
5.2.1 General.....	4
5.2.2 Test conditions.....	4
5.2.3 Apparatus.....	4
5.2.4 Procedure.....	4
5.2.5 Results.....	5
5.3 Testing of solar transmittance.....	5
5.3.1 General.....	5
5.3.2 Test conditions and apparatus.....	5
5.3.3 Procedure.....	5
5.3.4 Results.....	5
5.4 Testing of solar absorptance.....	5
5.4.1 General.....	5
5.4.2 Test conditions and apparatus.....	5
5.4.3 Procedure.....	5
5.4.4 Results.....	6
5.5 Testing of hemispherical emittance.....	6
5.5.1 General.....	6
5.5.2 Test conditions.....	6
5.5.3 Apparatus and procedure.....	6
5.5.4 Results.....	7
<b>6 Durability testing of evacuated tube</b> .....	<b>7</b>
6.1 Vacuum performance.....	7
6.1.1 General.....	7
6.1.2 Test conditions and apparatus.....	7
6.1.3 Procedure.....	8
6.1.4 Results.....	8
6.2 Resistance to thermal shock.....	8
6.2.1 General.....	8
6.2.2 Test conditions and apparatus.....	9
6.2.3 Procedure.....	9
6.2.4 Results.....	9
6.3 Resistance to impact.....	9
6.3.1 General.....	9
6.3.2 Principle.....	9
6.3.3 Procedure.....	9
6.3.4 Results.....	9
6.4 Resistance to internal pressure.....	10
6.4.1 General.....	10

6.4.2	Test conditions and apparatus.....	10
6.4.3	Procedure.....	10
6.4.4	Results.....	10
<b>7</b>	<b>Performance testing of evacuated tube.....</b>	<b>10</b>
7.1	Tests for determination the exposure parameter.....	10
7.1.1	General.....	10
7.1.2	Test conditions.....	11
7.1.3	Apparatus.....	11
7.1.4	Procedure.....	12
7.1.5	Results.....	13
7.2	Tests for determination of sum of solar irradiation for temperature increase of double-glass evacuated tube.....	13
7.2.1	General.....	13
7.2.2	Test conditions.....	13
7.2.3	Apparatus.....	13
7.2.4	Procedure and results.....	13
7.3	Tests to determine the average heat loss coefficient of a double-glass evacuated tube.....	13
7.3.1	General.....	13
7.3.2	Test conditions.....	14
7.3.3	Apparatus.....	14
7.3.4	Procedure.....	14
7.3.5	Results.....	15
<b>Annex A (informative) Configuration schemes of evacuated tubes.....</b>		<b>16</b>
<b>Annex B (normative) Test report.....</b>		<b>18</b>
<b>Annex C (normative) Determination of the external surface area of absorber tube for double-glass evacuated tubes.....</b>		<b>25</b>
<b>Bibliography.....</b>		<b>27</b>

## Foreword

ISO (the International Organization for Standardization) is a worldwide federation of national standards bodies (ISO member bodies). The work of preparing International Standards is normally carried out through ISO technical committees. Each member body interested in a subject for which a technical committee has been established has the right to be represented on that committee. International organizations, governmental and non-governmental, in liaison with ISO, also take part in the work. ISO collaborates closely with the International Electrotechnical Commission (IEC) on all matters of electrotechnical standardization.

The procedures used to develop this document and those intended for its further maintenance are described in the ISO/IEC Directives, Part 1. In particular the different approval criteria needed for the different types of ISO documents should be noted. This document was drafted in accordance with the editorial rules of the ISO/IEC Directives, Part 2 (see [www.iso.org/directives](http://www.iso.org/directives)).

Attention is drawn to the possibility that some of the elements of this document may be the subject of patent rights. ISO shall not be held responsible for identifying any or all such patent rights. Details of any patent rights identified during the development of the document will be in the Introduction and/or on the ISO list of patent declarations received (see [www.iso.org/patents](http://www.iso.org/patents)).

Any trade name used in this document is information given for the convenience of users and does not constitute an endorsement.

For an explanation on the meaning of ISO specific terms and expressions related to conformity assessment, as well as information about ISO's adherence to the World Trade Organization (WTO) principles in the Technical Barriers to Trade (TBT) see the following URL: [www.iso.org/iso/foreword.html](http://www.iso.org/iso/foreword.html).

The committee responsible for this document is ISO/TC 180, *Solar energy*.

ISO 22975 consists of the following parts, under the general title *Solar energy — Collector components and materials*:

- *Part 1: Evacuated tubes — Durability and performance*
- *Part 2: Heat-pipes for solar thermal application — Durability and performance*
- *Part 3: Absorber surface durability*

The following parts are under preparation:

- *Part 5: Insulation material durability and performance*

## **Introduction**

This part of ISO 22975 is applicable to all categories of evacuated tubes, including double-glass evacuated tubes and glass-metal sealed evacuated tubes.

This part of ISO 22975 provides test methods for inspecting stones and knots in envelope glass tubes.

This part of ISO 22975 also provides test methods for determining durability of evacuated tubes, including vacuum performance, thermal shock resistance, external impact resistance and internal pressure resistance. For each durability test, this part of ISO 22975 specifies general, apparatus, procedure and results of the test.

This part of ISO 22975 also provides test methods for measuring performance of evacuated tubes, including exposure parameter, solar irradiation for temperature increase of double-glass evacuated tube and average heat loss coefficient. For each performance test, principle, test conditions, apparatus, procedure and results of the test are specified.

# Solar energy — Collector components and materials —

## Part 1:

# Evacuated tubes — Durability and performance

## 1 Scope

This part of ISO 22975 specifies definitions and test methods for materials, durability and performance of evacuated tubes.

This part of ISO 22975 is applicable to all types of evacuated tubes.

## 2 Normative references

The following documents, in whole or in part, are normatively referenced in this document and are indispensable for its application. For dated references, only the edition cited applies. For undated references, the latest edition of the referenced document (including any amendments) applies.

ISO 9488, *Solar energy — Vocabulary*

ISO 9845-1, *Solar energy — Reference solar spectral irradiance at the ground at different receiving conditions — Part 1: Direct normal and hemispherical solar irradiance for air mass 1,5*

## 3 Terms and definitions

For the purposes of this document, the terms and definitions given in ISO 9488 and the following apply.

### 3.1

#### **double-glass evacuated tube**

component of an evacuated tube solar collector, of which both the inner tube and the envelope tube are made of glass

### 3.2

#### **glass-metal sealed evacuated tube**

component of an evacuated tube solar collector, in which the absorber is affixed to a metal fluid channel, that is sealed into the envelope glass tube through a specific glass-metal sealing process

### 3.3

#### **stone**

opaque inclusions in the glass of the evacuated tube

### 3.4

#### **knot**

transparent inclusions in the glass of the evacuated tube

### 3.5

#### **scratch**

abraded area where the surface of the glass is torn or worn off

### 3.6

#### **vacuum jacket**

space between envelope glass tube and absorber in an evacuated tube, wherein air pressure is sufficiently low that thermal conduction and convection of air can be ignored

**3.7 stagnation**  
state where no working fluid passes through the evacuated tube and the temperature of the evacuated tube is determined by the solar irradiance

**3.8 exposure temperature**  
maximum temperature at an accessible part of an evacuated tube with specified irradiance under *stagnation* (3.7) conditions

Note 1 to entry: For double glass evacuated tubes, the temperature with only air in the tube is measured. For direct flow tubes, the measurement is done in the air-filled flow channel within the vacuum tube. For glass-metal sealed tubes with heat pipe, the well-insulated condenser surface temperature is measured.

**3.9 exposure parameter**  
ratio of the difference between *exposure temperature* (3.8) and ambient temperature to the solar irradiance

**3.10 sum of solar irradiation for temperature increase**  
sum of solar irradiation for a certain preset temperature rise range of the water in a *double-glass evacuated tube* (3.1)

Note 1 to entry: This term applies only to double-glass evacuated tubes.

**3.11 average heat loss coefficient**  
ratio of heat loss per m<sup>2</sup> defined external surface area of absorber tube, without irradiance, to temperature difference between water content of vacuum tube and ambient air

Note 1 to entry: This term applies only to *double-glass evacuated tubes* (3.1).

## 4 Classification and test list

According to material category of absorber, evacuated tubes can be substantially classified into two types:

- a) double-glass evacuated tube, see [Figure A.1](#);
- b) glass-metal sealed evacuated tube, see [Figure A.2](#).

Tests for the two categories of evacuated tubes are summarized in [Table 1](#).

**Table 1 — Test list**

Category of evacuated tube	Test
Double-glass, Glass-metal sealed	<a href="#">5.1</a> Inspection for stones and knots
Double-glass, Glass-metal sealed	<a href="#">5.2</a> Inspection for scratches
Double-glass, Glass-metal sealed	<a href="#">5.3</a> Testing of solar transmittance
Double-glass	<a href="#">5.4</a> Testing of solar absorptance
Double-glass	<a href="#">5.5</a> Testing of hemispherical emittance
Double-glass	<a href="#">6.1</a> Vacuum performance
Double-glass	<a href="#">6.2</a> Resistance to thermal shock
Double-glass, Glass-metal sealed	<a href="#">6.3</a> Resistance to Impact
Double-glass, Glass-metal sealed direct flow	<a href="#">6.4</a> Resistance to internal pressure



Table 1 (continued)

Category of evacuated tube	Test
Double-glass, Glass-metal sealed	<a href="#">5.1</a> Inspection for stones and knots
Double-glass, Glass-metal sealed	<a href="#">7.1</a> Tests for determination of exposure parameter
Double-glass	<a href="#">7.2</a> Tests for determination of sum of solar irradiation for temperature increase of double-glass evacuated tube
Double-glass	<a href="#">7.3</a> Tests for determination the average heat loss coefficient of double-glass evacuated tube

## 5 Testing of material

### 5.1 Inspection for stones and knots

#### 5.1.1 General

This test is intended to check the uniformity of the tube glass by visual inspection.

#### 5.1.2 Test conditions

The test room/table for taking observations shall have a minimum illuminance of 1 500 lx.

#### 5.1.3 Apparatus

The dimension measurement instrument shall have an accuracy of  $\pm 0,1$  mm.

#### 5.1.4 Procedure

- a) Draw two lines with permanent marker or other non-invasive marking method with thickness no more than 0,5 mm on the surface of tube along the axial direction, such that the surface is split into two equal parts.
- b) With one part upward, count and separately record for this part the numbers of the following:
  - stones with size not over 1 mm;
  - stones with size over 1 mm;
  - knots with size not over 1,0 mm;
  - knots with size between 1,5 mm and 2,0 mm;
  - knots with size over 2,0 mm;
  - cracks around the stones and knots.
- c) Turn the other part of the tube upward and repeat Step b).
- d) Sum the values from Steps b) and c) for each category of stone, knot or crack.
- e) Draw another pair of lines parallel with the first pair of lines, ensuring that the distance between lines is 1/4 of the perimeter. Erase the first pair of lines and count and record the stones, knots and cracks again as in Steps b) to d).
- f) For each category of stone, knot or crack, take the larger of the values recorded in Steps d) and e) as the result.

### **5.1.5 Results**

Report the following values:

- a) the number of stones with size not over 1 mm, per unit area of the tube;
- b) the number of stones with size over 1 mm on the whole tube;
- c) the total number of stones on the whole tube;
- d) the number of knots with size not over 1,0 mm, per unit area of the tube;
- e) the number of knots with size between 1,5 mm and 2,0 mm on the whole tube;
- f) the number of knots with size over 2,0 mm on the whole tube;
- g) the number of cracks on the whole tube.

## **5.2 Inspection for scratches**

### **5.2.1 General**

This test will check and record the scratches on the tube by visual inspection.

NOTE The presence of scratches is one of the main reasons for tubes being broken.

### **5.2.2 Test conditions**

The test room/table for taking observations shall have a minimum illuminance of 1 500 lx.

### **5.2.3 Apparatus**

The dimension measurement instrument shall have an accuracy of  $\pm 0,1$  mm.

### **5.2.4 Procedure**

- a) Draw two lines with permanent marker or other non-invasive marking method with the thickness no more than 0,5 mm on the surface of tube along the axial direction, such that the surface is split into two equal parts.
- b) With one part upward, count and separately record for this part:
  - the number of scratches not longer than 100 mm;
  - the number of scratches longer than 100 mm;
  - the total length of all scratches.
- c) Turn the other part of the tube upward and repeat Step b).
- d) Sum the respective values from Steps b) and c).
- e) Draw another pair of lines parallel with the first pair of lines, ensuring that the distance between lines is 1/4 of the perimeter. Erase the first pair of lines, count and record the scratches again as in Steps b) to d).
- f) Take the larger value of each of the quantities recorded in Steps d) and e) as the results.

### 5.2.5 Results

Report the following values:

- a) the number of scratches not longer than 100 mm on the whole tube;
- b) the number of scratches longer than 100 mm on the whole tube;
- c) the total length of all scratches on the whole tube.

## 5.3 Testing of solar transmittance

### 5.3.1 General

This test will determine the solar transmittance (AM1.5) of the envelope glass tube.

### 5.3.2 Test conditions and apparatus

This test shall use a spectrophotometer with a wavelength accuracy of  $\pm 1$  nm, resolution of 0,1 nm, range of 0,3  $\mu\text{m}$  to 2,5  $\mu\text{m}$  and an integrating-sphere unit. The measuring spot of the spectrophotometer and the opening of the integrating sphere shall be sized to ensure that the curvature of the tube has no influence on the result.

### 5.3.3 Procedure

The solar transmittance of a sample piece of the envelope tube is tested twice. In the first test, place the sample into the measuring spot with the light incident on the concave surface and measure the transmittance of the sample with the spectrophotometer for solar spectral irradiance according to ISO 9845-1. In the second test, place the sample into the measuring spot with the light incident on the convex surface and measure the transmittance of the sample with the spectrophotometer for solar spectral irradiance according to ISO 9845-1.

### 5.3.4 Results

The transmittance for solar spectral irradiance according to ISO 9845-1 shall be reported for both measurements and the mean value of the two measurements.

## 5.4 Testing of solar absorptance

### 5.4.1 General

This test will determine the solar absorptance (AM1.5) of selective absorbing coating of a double-glass evacuated tube. This test is applicable for double glass evacuated tubes only.

### 5.4.2 Test conditions and apparatus

This test shall use a spectrophotometer with a wavelength accuracy of  $\pm 1$  nm, resolution of 0,1 nm, range of 0,3  $\mu\text{m}$  to 2,5  $\mu\text{m}$  and an integrating-sphere unit. The measuring spot of the spectrophotometer and the opening of the integrating sphere shall be sized to ensure that the curvature of the tube has no influence on the result.

### 5.4.3 Procedure

Two samples of the solar selective surface shall be taken; one from a position 150 mm distant from the open end of the tube and one from the middle of the tube. For each sample, position the sample into the measuring spot with the light incident on the convex surface and measure the reflectance for solar spectral irradiance according to ISO 9845-1.

#### 5.4.4 Results

Calculate and report the solar absorptance for each sample from the measured reflectance and the mean of these two absorptance results.

### 5.5 Testing of hemispherical emittance

#### 5.5.1 General

This test will determine the hemispherical emittance of selective absorbing coating of a double-glass evacuated tube.

#### 5.5.2 Test conditions

The hemispherical emittance of the selective absorbing coating on the outside of the inner glass tube of an double-glass evacuated tube is determined by steady state calorimetry at a temperature of  $80\text{ °C} \pm 5\text{ °C}$ .

NOTE The gas pressure in the vacuum jacket is typically around  $5 \times 10^{-2}$  Pa, so the conduction of gas molecules can be ignored.

The hemispherical emittance of the selective surface  $\varepsilon_h$  is as given in [Formula \(1\)](#):

$$\varepsilon_h = \frac{IU}{\sigma A_1 (T_1^4 - T_2^4)} = \frac{q_s}{q_b} \quad (1)$$

where

$I$  is the current of heater, A;

$U$  is the voltage of heater, V;

$A_1$  is the reference area of the outside of inner glass tube,  $\text{m}^2$ ;

$\sigma$  is the Stefan-Boltzmann constant,  $5,67 \times 10^{-8} \text{ W}\cdot\text{m}^{-2} \text{ K}^{-4}$ ;

$T_1$  is the temperature of heater at steady state, K;

$T_2$  is the temperature of cooling water, K;

$q_s$  is the emissive power density of selective absorbing surface,  $\text{W}\cdot\text{m}^{-2}$ ;

$q_b$  is the emissive power density of black body,  $\text{W}\cdot\text{m}^{-2}$ .

#### 5.5.3 Apparatus and procedure

A double-glass evacuated tube is placed into a water-cooled jacket and heating elements are inserted into the tube. The heating elements consist of the central main heater and the compensating heaters at the ends of the main heater.

The heater elements are contained within three segments of ceramic tube which fit within the inner glass absorber tube. Temperature sensors are attached to each ceramic element allowing the temperature of each to be measured and controlled independently. The temperature sensor in the inner tubes shall be recorded to a standard uncertainty of 0,2 K. The power dissipated in the central heater required to maintain the absorber tube at a chosen constant temperature is used to evaluate average heat loss of the heater. The outer segments are maintained at the same temperature as the central segment by means of independent power inputs, to prevent longitudinal heat flow. Consequently, only radial dissipation of the power need to be considered. The glass envelope is enclosed in a water cooled jacket and its temperature is thus maintained at  $20\text{ °C}$ .

Operate the apparatus until the heaters have stabilised at a temperature of  $80\text{ °C} \pm 5\text{ °C}$ . Determine the voltage,  $U$ , and current,  $I$ , supplied to the main heater. Determine the reference area,  $A_1$ , of the outer surface of inner glass tube in direct contact with the main heater. Calculate the hemispherical emittance in accordance with [Formula \(1\)](#).

For test apparatus, see [Figure 1](#).

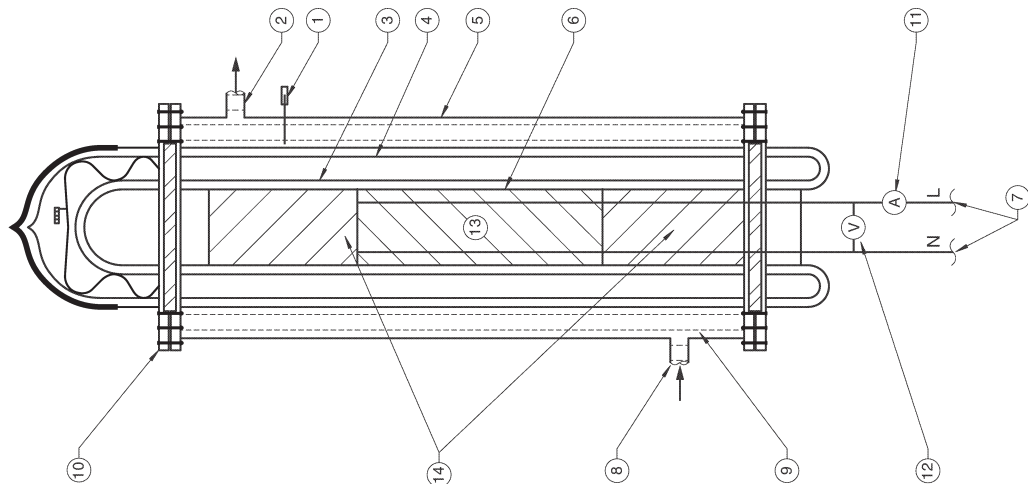

#### Key

1	temperature (T1) sensor of cooling water	8	inlet of cooling water
2	outlet of cooling water	9	cooling water
3	inner glass tube	10	sealing flanges of water cooled jacket
4	envelope glass tube	11	amperemeter
5	water cooled jacket	12	voltmeter
6	temperature (T2) sensor of central heater	13	central heater
7	wires of central heater	14	auxiliary heater

**Figure 1 — Test apparatus for hemispherical emittance**

#### 5.5.4 Results

The test report shall record the hemispherical emittance of a solar selective absorbing coating  $\epsilon_h$ .

## 6 Durability testing of evacuated tube

### 6.1 Vacuum performance

#### 6.1.1 General

This test is intended to assess, for a double-glass evacuated tube, the air pressure of the vacuum jacket and the disappearance percentage in axial length of the getter mirror after the tube is heated for 48 h at a temperature of  $350\text{ °C} \pm 5\text{ °C}$ .

#### 6.1.2 Test conditions and apparatus

The air pressure of the vacuum jacket is assessed using a spark leak detector in a darkened room or enclosure.

For assessment of the disappearance percentage in axial length of the getter mirror of a double-glass evacuated tube, a heating rod shall heat up the inner tube without direct contact with the glass. The

heating rod shall have a length not less than 90 % of the tube length and the end of the tube shall be well insulated. The temperature within the tube shall be measured using a temperature sensor in the middle of the tube close to the tube wall, to a standard uncertainty of 1 K. the temperature in the inner tubes shall be kept at  $350\text{ °C} \pm 5\text{ °C}$  for 48 h.

### 6.1.3 Procedure

With a new tube, apply testing with the spark leak detector to assess air pressure of vacuum jacket in the evacuated tubes in dark condition. Make qualitative judgments according to the appearance of the discharge.

For a double-glass evacuated tube, the spark leak detector shall be aimed at the open end of the tube where no selective coating is on the inner glass tube. Turn on the spark leak detector in dark condition, record the test results. If the tube is not leaky, the glass surface shows weak fluorescence. Otherwise, if the glow discharge appears in the tube, sparks penetrate on the glass surface or sparks are divergent whereas no fluorescence on the glass surface, the tube is leaky.

Repeat the spark leak detector test with a second tube.

For the disappearance percentage test, the following procedure shall be used with a new tube.

- a) Determine the axial length,  $L_1$ , of the getter mirror, from the point at the closed end of the tube where outside diameter is 15 mm to the getter mirror edge. Six measurements shall be made, equally spaced around the circumference of the tube, and averaged to give the length value.
- b) Insert the heating rod into the evacuated tube.
- c) Maintain the inner glass tube at a temperature of  $350\text{ °C} \pm 5\text{ °C}$  for 48 h and record the air temperature in the inner tube during this period.
- d) After the tube has cooled to room temperature, determine the axial length,  $L_2$ , of the getter mirror, in accordance with Step a).

### 6.1.4 Results

The appearance of the discharge, when the tubes are tested by the spark leakage detector, shall be reported.

For a double-glass evacuated tube, the disappearance percentage in axial length of the getter mirror shall be calculated according to [Formula \(2\)](#) and reported.

$$R = \frac{L_1 - L_2}{L_1} \times 100 \quad (2)$$

where

$R$  is the disappearance percentage in axial length of the getter mirror, %;

$L_1$  is the axial length of the getter mirror before heating, mm;

$L_2$  is the axial length of the getter mirror after heating, mm.

## 6.2 Resistance to thermal shock

### 6.2.1 General

This test is intended to assess the capability of an evacuated tube to withstand thermal shocks without failure. This test applies to double glass evacuated tubes.

## 6.2.2 Test conditions and apparatus

This test uses an ice-water mixture bath at a temperature not higher than 0 °C and a hot water bath at a temperature above 90 °C. For both baths, the temperature shall be stable within  $\pm 0,5$  °C.

## 6.2.3 Procedure

- a) Insert the open end of evacuated tube into the ice-water mixture bath to a depth not less than 100 mm for 1 min.
- b) Remove the tube from ice-water mixture bath and immediately insert it into hot water bath to a depth not less than 100 mm for 1 min.
- c) Remove the tube from hot water bath and immediately insert it again into ice-water mixture bath to a depth not less than 100 mm for 1 min.
- d) Repeat Steps b) and c) three times.

## 6.2.4 Results

Record any damage to the evacuated tube and the temperature of the testing baths during the testing.

## 6.3 Resistance to impact

### 6.3.1 General

This test is intended to assess the extent to which an evacuated tube can withstand the effects of heavy impacts caused by hailstones.

### 6.3.2 Principle

A steel ball is dropped onto the evacuated tube from specified heights. The impact energy is gradually increased by increasing the height up to a maximum of 2,0 m, until either the tube breaks or the manufacturer's specified maximum height is reached.

### 6.3.3 Procedure

- a) Mount both ends of collector tube horizontally on a support that is stiff enough so that there is negligible distortion or deflection at the time of impact.
- b) Drop a steel ball with a mass of  $150 \text{ g} \pm 10 \text{ g}$  vertically onto a point 75 mm from one end of the tube, in a direction normal to the tube axis, from a height of 0,4 m or other minimum height specified by the manufacturer of the tube. The height of drop is the vertical distance between the point of release and the horizontal plane containing the point of impact.
- c) Repeat Step b) once, with the point of impact moved by a few millimetres from all previous points of impact.
- d) Repeat Steps b) and c) with the ball dropped onto a point 75 mm from the other end of the tube.
- e) Repeat Steps b), c) and d) with the ball dropped successively from heights of 0,6 m, 0,8 m, 1,0 m, 1,2 m, 1,4 m, 1,6 m, 1,8 m and 2,0 m. The test is terminated if the tube is destroyed or if the height exceeds the maximum specified by the manufacturer of the tube.

### 6.3.4 Results

All points of impact shall be reported and illustrated by means of photographs in the test report, together with the heights from which the steel balls were dropped. The results of the collector tube inspection shall be reported, together with the number of impacts and the impact locations.



The test report shall include descriptions and illustrations of major failures.

Major failures are mechanical defects affecting negatively the durability of the collector tube or its power output, or influencing negatively the safety of the product. They include, e.g. breaking of the glass, other damage to the cover or other collector tube parts, leakages, dissolution of coating, radiation scattering through the cover, etc.

## **6.4 Resistance to internal pressure**

### **6.4.1 General**

This test is intended to assess the extent to which a double-glass evacuated tube or a glass-metal sealed direct flow evacuated tube can withstand the internal fluid pressures to which it might be subjected in service. Make sure that the tubes are protected from any light during the test.

### **6.4.2 Test conditions and apparatus**

The apparatus consists of a hydraulic pressure source (electrical pump or hand pump), a safety valve, an air-bleed valve and a pressure gauge with a standard uncertainty better than 5 %.

During this test, the tubes shall be protected from any light.

### **6.4.3 Procedure**

Fill a double-glass evacuated tube or/and a glass-metal sealed evacuated tube with U-tube or concentric-tube with water at room temperature. Use the air-bleed valve to empty the fluid channels of air before pressurization.

Raise the water pressure smoothly to 1,5 times the maximum collector operating pressure specified by the manufacturer and maintain for 15 min.

While the pressure is maintained, inspect the fluid channels for swelling, distortion or ruptures.

### **6.4.4 Results**

Any damage to the tube shall be reported and illustrated by means of photographs in the test report.

## **7 Performance testing of evacuated tube**

### **7.1 Tests for determination the exposure parameter**

#### **7.1.1 General**

This test is intended to determine exposure parameter of a double-glass evacuated tube and a glass-metal sealed evacuated tube with heat-pipe.

The exposure parameter ( $Y$ ) of an evacuated tube can be calculated according to [Formula \(3\)](#):



$$Y = \frac{\vartheta_e - \vartheta_a}{G} \quad (3)$$

where

$Y$  is the exposure parameter of evacuated tube,  $(\text{m}^2 \cdot \text{K})/\text{W}$ ;

$\vartheta_e$  is the exposure temperature of evacuated tube,  $^{\circ}\text{C}$ ;

$\vartheta_a$  is the average ambient temperature,  $^{\circ}\text{C}$ ;

$G$  is the hemispherical solar irradiance,  $\text{W}/\text{m}^2$ .

### 7.1.2 Test conditions

The test shall be conducted outdoors. During the test, hemispherical solar irradiance ( $G$ ) shall not be lower than  $800 \text{ W}/\text{m}^2$ , ambient temperature ( $\vartheta_a$ ) shall be in the range  $8 \text{ }^{\circ}\text{C}$  to  $39 \text{ }^{\circ}\text{C}$  and wind speed shall not be greater than  $4 \text{ m}/\text{s}$ .

### 7.1.3 Apparatus

Three evacuated tubes shall be mounted on a fixture in a north-south orientation, at a centre spacing of twice the tube diameter. The tube under test shall be in the middle.

The fixture shall include a flat sheet with low reflectance black surface behind and parallel to the tubes, and a pyranometer parallel to the black sheet.

For test apparatus, see [Figure 2](#) and [Figure 3](#).

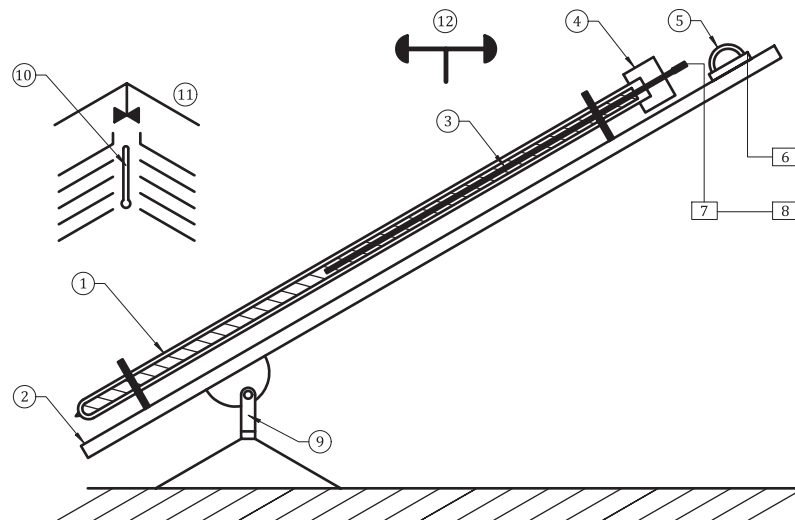

#### Key

- |   |                             |    |                      |
|---|-----------------------------|----|----------------------|
| 1 | double-glass evacuated tube | 7  | temperature recorder |
| 2 | flat backing plate          | 8  | printer              |
| 3 | temperature sensor          | 9  | support              |
| 4 | insulation cap              | 10 | temperature sensor   |
| 5 | pyranometer                 | 11 | thermometer screen   |
| 6 | solar irradiance recorder   | 12 | anemometer           |

**Figure 2 — Test apparatus for double-glass evacuated tube**

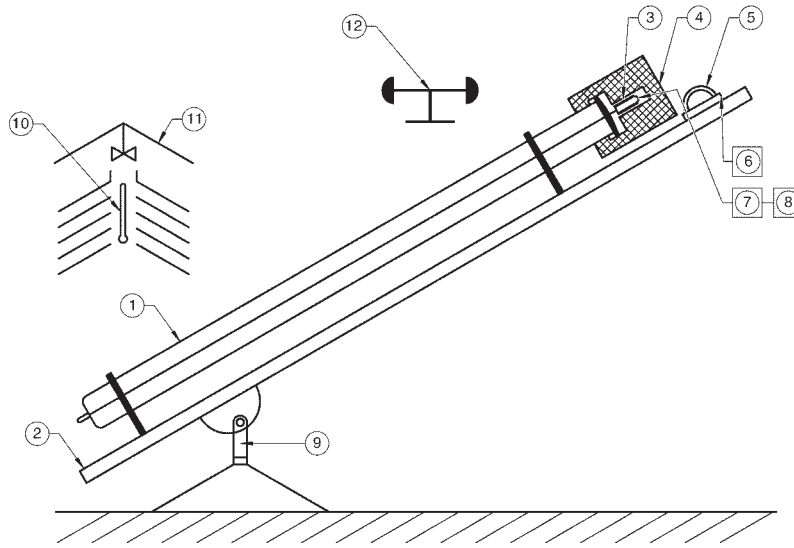

**Key**

- |   |  |    |                      |
|---|--|----|----------------------|
| 1 | glass-metal sealed evacuated tube with heat-pipe | 7  | temperature recorder |
| 2 | flat backing plate                               | 8  | printer              |
| 3 | temperature sensor                               | 9  | support              |
| 4 | insulation cap                                   | 10 | temperature sensor   |
| 5 | pyranometer                                      | 11 | thermometer screen   |
| 6 | solar irradiance recorder                        | 12 | anemometer           |

**Figure 3 — Test apparatus for glass-metal sealed evacuated tube with heat-pipe**

Double-glass evacuated tube: The working fluid in the tube shall be air. A temperature sensor shall be positioned in the middle of the tube, not in contact with the inner wall of the tube. The open end of the tube shall be insulated with a cap of 50 mm thickness and thermal conductivity no greater than 0,022 W/(m·K). The cap shall cover exactly that part of the inner tube with no selective absorbing coating.

Glass-metal sealed evacuated tube with heat-pipe: A temperature sensor shall be placed in good thermal contact with the middle of the heat-pipe condenser. The outside of the evacuated tube, including the heat-pipe condenser, glass-metal seal and metallic pipework shall be insulated with minimum 50 mm thickness of insulation with thermal conductivity no greater than 0,022 W/(m·K).

The test fixture shall be adjusted so that the solar radiation is incidence onto the tube within  $\pm 2^\circ$  of normal. For a double-glass evacuated tube, the plane of the tube shall be not less than  $30^\circ$  from the horizontal plane. For a glass-metal sealed evacuated tube, the plane of the tube shall be in a range  $30^\circ$  to  $60^\circ$  from the horizontal plane.

Measuring instruments shall meet the following requirements:

- a) pyranometer, class I or better;
- b) temperature sensor, with an accuracy of  $\pm 0,2^\circ\text{C}$ ;
- c) anemometer, with an accuracy of  $\pm 0,5\text{ m/s}$ .

**7.1.4 Procedure**

During the testing, hemispherical solar irradiance ( $G$ ) shall not be lower than  $800\text{ W/m}^2$ , fluctuations shall not be more than  $\pm 30\text{ W/m}^2$  in 15 min, and fluctuations of the temperature in the middle of the tube shall not be more than 1,0 K. Take four recordings each of solar irradiance, temperature in tube or attached to the heat-pipe condenser and ambient temperature at 5 min intervals. Calculate the

averages of these readings to give exposure temperature ( $\vartheta_e$ ) of the evacuated tube, hemispherical solar irradiance ( $G$ ) and ambient temperature ( $\vartheta_a$ ), respectively.

### 7.1.5 Results

Using the calculated values for exposure temperature ( $\vartheta_e$ ), hemispherical solar irradiance ( $G$ ) and ambient temperature ( $\vartheta_a$ ), calculate the exposure parameter ( $Y$ ) of the evacuated tube according to [Formula \(3\)](#).

## 7.2 Tests for determination of sum of solar irradiation for temperature increase of double-glass evacuated tube

### 7.2.1 General

This test is intended to determine sum of solar irradiation for a temperature increase of 35 K for the water in a double-glass evacuated tube.

### 7.2.2 Test conditions

Test conditions shall be the same as described in [7.1.2](#).

### 7.2.3 Apparatus

Test apparatus shall be the same as described in [7.1.3](#) except that the working fluid in the double-glass evacuated tube shall be water.

Measuring instruments shall be the same as described in [7.1.3](#) except the solar irradiation recorder shall have the function to integrate the output of the pyranometer.

### 7.2.4 Procedure and results

At beginning of test, the temperature of water in the double-glass evacuated tube shall be lower than ambient temperature.

Expose the evacuated tube to the specified hemispherical solar irradiance. Record the initial sum of solar irradiation when the water temperature in the tube is equal to the ambient temperature.

When the water temperature in the tube rises by 35 K, record the final sum of solar irradiation.

Calculate the sum of solar irradiation for temperature increase of the double-glass evacuated tube as the difference between the final sum of solar irradiation and the initial sum of solar irradiation.

## 7.3 Tests to determine the average heat loss coefficient of a double-glass evacuated tube

### 7.3.1 General

This test is intended to determine the average heat loss coefficient of a double-glass evacuated tube.

The average heat loss coefficient ( $U_{LT}$ ) of the double-glass evacuated tube can be calculated according to [Formula \(4\)](#), [Formula \(5\)](#) and [Formula \(6\)](#), respectively.

$$U_{LT} = \frac{c_{pw} M (\vartheta_1 - \vartheta_3)}{A_A (\vartheta_m - \vartheta_a) \Delta \tau} \quad (4)$$

$$\vartheta_m = \frac{\vartheta_{w1} + \vartheta_{w2} + \vartheta_{w3}}{3} \quad (5)$$

$$\vartheta_a = \frac{\vartheta_{a1} + \vartheta_{a2} + \vartheta_{a3}}{3} \quad (6)$$

where

- $U_{LT}$  is the average heat loss coefficient, W/(m<sup>2</sup>·K);
- $\vartheta_m$  is the average water temperature in the tube during test, °C;
- $\vartheta_a$  is the average ambient temperature, °C;
- $\Delta\tau$  is the total test duration from water temperature  $\vartheta_1$  to  $\vartheta_3$ , s;
- $M$  is the water mass in double-glass evacuated tube, kg;
- $c_{pw}$  is the specific heat of water, J/(kg·K);
- $A_A$  is the external surface area of absorber tube, m<sup>2</sup>;
- $\vartheta_{w1}, \vartheta_{w2}, \vartheta_{w3}$  is the water temperature in the tube at first, second and third recording events, respectively, °C;
- $\vartheta_{a1}, \vartheta_{a2}, \vartheta_{a3}$  is the ambient temperature at first, second and third recording events, respectively, °C

### 7.3.2 Test conditions

The test shall be conducted indoors away from direct solar irradiation and with no draft impinging directly on the double-glass evacuated tube. During the test, ambient temperature shall be maintained at 23 °C ± 2 °C.

### 7.3.3 Apparatus

The double-glass evacuated tube shall be placed vertically with the open end upwards. The open end shall be covered with an insulation cap in accordance with [7.1.3](#).

Three temperature sensors shall be positioned in the double-glass evacuated tube, at distances from the open end of 1/6, 1/2 and 5/6 of the tube length, respectively. Water temperature in the tube,  $\vartheta_w$ , is the average of the temperature values indicated by these three sensors.

Measuring instruments shall meet the following requirement:

- temperature sensor, with an accuracy of ±0,2 °C.

### 7.3.4 Procedure

- a) Preheat the double-glass evacuated tube by filling with hot water above 90 °C then after 2 min, drain the water from the tube.
- b) Immediately fill the tube with hot water above 90 °C to a level between 40 mm and 50 mm from the open end.
- c) When the water temperature,  $\vartheta_w$ , falls by natural cooling to 80 °C ± 0,2 °C, record the first water temperature ( $\vartheta_{w1}$ ) and first ambient temperature ( $\vartheta_{a1}$ ).
- d) Repeat Step c) twice at intervals of 30 min to obtain the second ( $\vartheta_{w2}, \vartheta_{a2}$ ) and third ( $\vartheta_{w3}, \vartheta_{a3}$ ) values of water and ambient temperature, respectively.

### 7.3.5 Results

Determine the external surface area  $A_A$  of the absorber tube in accordance with [Table C.1](#) or [Formula \(C.1\)](#).

Calculate the average heat loss coefficient ( $U_{LT}$ ) of the double-glass evacuated tube according to [Formula \(4\)](#), [Formula \(5\)](#) and [Formula \(6\)](#).

## Annex A (informative)

### Configuration schemes of evacuated tubes

#### A.1 Configuration scheme of double-glass evacuated tube

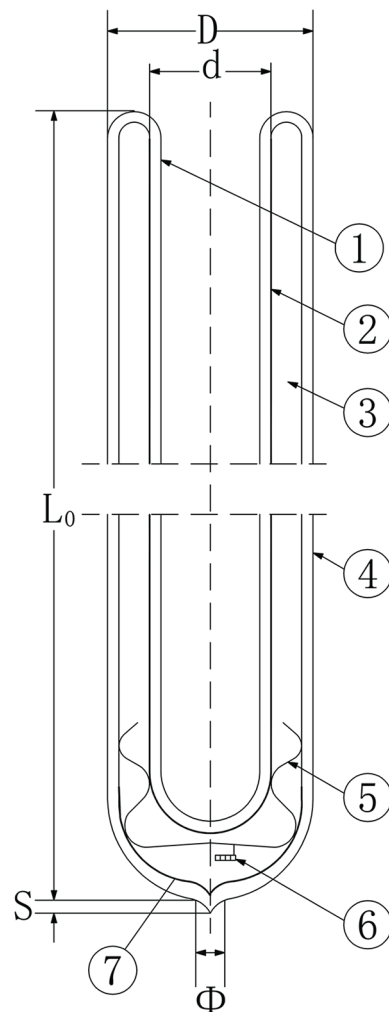

**Key**

- |   |                                   |                       |                                       |
|---|-----------------------------------|-----------------------|---------------------------------------|
| 1 | inner glass tube (absorber tube)  | 7                     | getter mirror                         |
| 2 | solar selective absorbing coating | <i>D</i>              | outer diameter of envelope glass tube |
| 3 | vacuum jacket                     | <i>d</i>              | outer diameter of inner glass tube    |
| 4 | envelope glass tube               | <i>L</i> <sub>0</sub> | length of evacuated tube              |
| 5 | supporting part                   | <i>S</i>              | length of sealing section             |
| 6 | evaporable getter                 | Φ                     | diameter of sealing section           |

**Figure A.1 — Configuration scheme of double-glass evacuated tube**

## A.2 Configuration scheme of glass-metal sealed evacuated tube

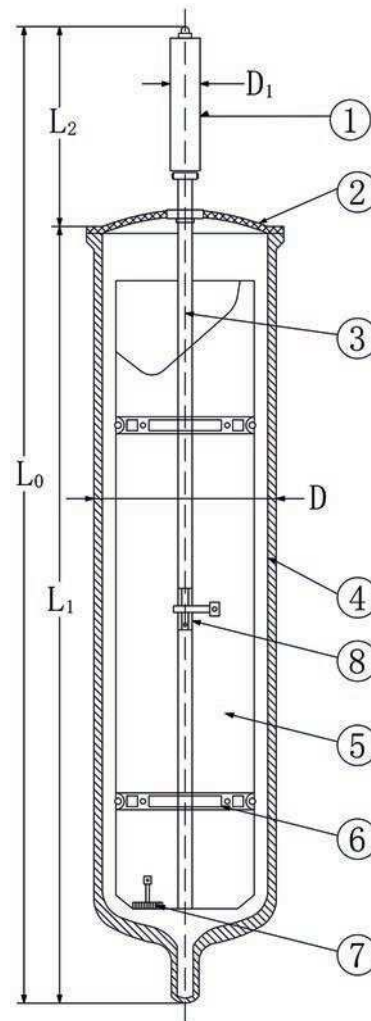

### Key

1	condenser of heat-pipe	8	non-evaporable getter
2	metal sealing part	$D_1$	outer diameter of condenser
3	evaporator of heat-pipe	$D$	outer diameter of envelope glass tube
4	envelope glass tube	$L_0$	length of evacuated tube
5	absorber plate	$L_1$	length of envelope glass tube
6	supporting part	$L_2$	length of condenser
7	evaporable getter		

NOTE 1 This figure shows the configuration scheme of a glass-metal sealed evacuated tube with heat-pipe.

NOTE 2 For a glass-metal sealed evacuated tube with U-tube, a U-tube will replace the heat-pipe.

NOTE 3 For a glass-metal sealed evacuated tube with concentric-tube, a concentric-tube will replace the heat-pipe.

NOTE 4 In this figure, the exhaust pipe is in the glass tube; there are also evacuated tubes where the exhaust pipe is integrated with the metal sealing part.

**Figure A.2 — Configuration scheme of glass-metal sealed evacuated tube**

**Annex B**  
**(normative)**

**Test report**

**B.1 General**

Evacuated tube reference No: .....

Test performed by: .....

Address: .....

Date, Telephone, Fax: .....

**B.2 Description of evacuated tube**

Name of manufacturer: .....

Name of brand: .....

Serial No: .....

Drawing document No: .....

Year of production: .....

**Double-glass evacuated tube:**

Type name: .....

Diameter of evacuated tube: ..... mm

Length of evacuated tube: ..... mm

Length of absorber plate of glass-metal sealed evacuated tube: ..... mm

Width of absorber plate of glass-metal sealed evacuated tube: ..... mm

Diameter of absorber tube of double-glass evacuated tube: ..... mm

External surface areas of absorber tube of double-glass evacuated tube: ..... m<sup>2</sup>

Glass material .....

Selective coating: .....

Air pressure in vacuum jacket: .....

Structural type (with heat-pipe/U-tube/concentric-tube): .....

Configuration scheme of tube: .....



Photograph of tube: .....

Maximum operating temperature:..... °C

Maximum operating pressure: ..... kPa

### B.3 Testing of material

#### B.3.1 Inspection of stones and knots

A visual inspection method is adopted for stones and knots in the envelope glass tube specified in [5.1.4](#). The inspecting result is given in [Table B.1](#).

**Table B.1 — Results of the inspection of stones and knots**

Item	Quantity	Remark
Stones with size not over 1 mm within area 10 mm × 10 mm		
Stones on the whole tube		
Cracks on the whole tube		
Stones with size over 1 mm on the whole tube		
Knots with size not over 1,0 mm on the tube within area 10 mm × 10 mm		
Knots with size between 1,5 mm and 2,0 mm on the whole tube		
Knots with size over 2,0 mm on the whole tube		

#### B.3.2 Inspection of scratches

A visual inspection method shall be adopted for scratches in glass tube. The inspecting result is given in [Table B.2](#).

**Table B.2 — Results of the inspection of scratches**

Item	Quantity	Remark
Scratches are not longer than 100 mm		
Scratches are longer than 100 mm		
Total length of all the scratches		

#### B.3.3 Testing of solar transmittance

The inspecting result is given in [Table B.3](#).

**Table B.3 — Results of the testing of solar transmittance**

Item	Quantity	Remark
The solar transmittance of first measurement		
The solar transmittance of second measurement		
The mean value of two measurements		

#### B.3.4 Testing of solar absorptance

The testing result is given in [Table B.4](#).

**Table B.4 — Results of the testing of solar absorptance**

Item	Quantity	Remark
The solar absorptance of first sample		
The solar absorptance of second sample		
The mean value of two measurements		

**B.3.5 Testing of hemispherical emittance**

The testing result is given in [Table B.5](#).

**Table B.5 — Results of the testing of hemispherical emittance**

Item	Quantity	Remark
The measured hemispherical emittance		

**B.4 Durability test**

**B.4.1 Summary of main results for durability tests**

All significant damage to the evacuated tube should be summarized in [Table B.6](#). Full details should be given in the individual test result sheet.

**Table B.6 — Summary of main results for durability tests**

Test	Date		Summary of main test results
	Start	End	
Vacuum performance			
Thermal shock resistance			
Impact resistance			
Internal pressure resistance			
Final inspection			

Remarks: .....

.....

**B.4.2 Vacuum performance test**

**B.4.2.1 Vacuum jacket air pressure test**

Air pressure of vacuum jacket in the evacuated tube should be tested using a spark leak detector in dark condition.

Test results are given as follows.

- Glass surface shows weak fluorescence
- Glow discharge appears
- Sparks penetrate on the glass surface
- Sparks are divergent whereas no fluorescence on the glass surface

**B.4.2.2 Vacuum quality test**

After the Inner glass tube is heated, specified in 6.1.2, the disappearance ratio *R* in axial length of the getter mirror should be measured.

**Test conditions:**

Heating rod length: ..... mm

Heating temperature: ..... °C

Heating duration: ..... h

Test results are given in Table B.7.

**Table B.7 — Results of the vacuum quality test**

Measuring point	Axial length of the getter mirror (mm)	
	Before heating ( <i>L</i> <sub>1</sub> )	After heating ( <i>L</i> <sub>2</sub> )
1		
2		
3		
4		
5		
6		
Average value		

**B.4.3 Thermal shock resistance test**

After thermal shock resistance test specified in 6.2.3, the evacuated tube should be inspected for damage.

Test results are given in Table B.8.

**Table B.8 — Results of the thermal shock resistance test**

No	Inserted depth of evacuated tube (mm)	Temperature of ice-water mixture (°C)	Temperature of hot water (°C)	Inserted duration of evacuated tube (min)
1				
2				
3				

**B.4.4 Impact resistance test**

After impact resistance test specified in 6.3.2, the evacuated tube shall be inspected for damage.

**Test conditions:**

Diameter of solid steel ball: ..... mm

Height from bottom of steel ball to impact point: ..... mm

**Test results:**

Give details of leakage, breakage, distortion or deformation and any of the failures.

.....  
 .....

**B.4.5 Internal pressure resistance test**

After internal pressure resistance test specified in [6.4.3](#), the double-glass evacuated tube should be inspected for damage.

For a glass-metal sealed evacuated tube with U-tube or concentric-tube, after internal pressure resistance test specified in [6.4.3](#), it should be inspected for damage.

Maximum operating pressure specified by manufacturer: ..... kPa

**Test conditions:**

Test temperature: ..... °C

Test pressure: ..... kPa

Test duration: ..... min

**Test results:**

Give details of leakage, breakage, distortion or deformation and any of the failures.

.....  
 .....

**B.5 Performance test**

**B.5.1 Determination of exposure parameter**

After measuring the exposure temperature specified in [7.1.1](#), calculate the exposure parameter value (Y) according to [Formula \(3\)](#).

**Test conditions:**

Solar irradiance range during test:..... W/m<sup>2</sup>

Ambient temperature range during test: ..... °C

Maximum wind speed during test:..... m/s

Tilt angle of evacuated tube: ..... °

Test results are given in [Table B.9](#).

**Table B.9 — Results of the determination of exposure parameter**

No	Solar irradiance <i>G</i> (W/m <sup>2</sup> )	Exposure temperature <i>θ<sub>e</sub></i> (°C)	Ambient temperature <i>θ<sub>a</sub></i> (°C)	Wind speed (m/s)
1				
2				
3				
4				
Average				

### B.5.2 Determination of solar irradiation for temperature increase of double-glass evacuated tube

As soon as water temperature rising in the tube reaches 35 K specified in [7.2.4](#), record solar irradiation for the double-glass evacuated tube.

#### Evacuated tube:

Diameter of evacuated tube: ..... mm

#### Test conditions:

Solar irradiance range during test: ..... W/m<sup>2</sup>

Ambient temperature range during test: ..... °C

Maximum wind speed during test: ..... m/s

Tilt angle of evacuated tube: ..... °

Test results are given in [Table B.10](#).

**Table B.10 — Results of the determination of solar irradiation for temperature increase of double-glass evacuated tube**

Parameter	Reading	Remark
Initial ambient temperature (°C)		
Initial water temperature in tube (°C)		
Final water temperature in tube (°C)		
Temperature rising in tube (°C)		
Initial solar irradiation reading (MJ/m <sup>2</sup> )		
Final solar irradiation reading (MJ/m <sup>2</sup> )		
Solar irradiation for temperature increase (MJ/m <sup>2</sup> )		

### B.5.3 Determination of average heat loss coefficient

After measuring the water temperature in tube and ambient temperature specified in [7.3.4](#), calculate the average heat loss coefficient ( $U_{LT}$ ) according to [Formula \(3\)](#), [Formula \(4\)](#) and [Formula \(5\)](#).

#### Evacuated tube:

Diameter of evacuated tube: ..... mm

Length of evacuated tube: ..... mm

Diameter of absorber tube: ..... mm

External surface areas of absorber tube: ..... m<sup>2</sup>

#### Test conditions:

Ambient temperature range during test: ..... °C

Maximum wind speed during test: ..... m/s

Initial water temperature in tube: ..... °C

Time interval between two readings: ..... min

Test results are given in [Table B.11](#).

**Table B.11 — Results of the determination of average heat loss coefficient**

No	Water temperature along tube (°C)				Ambient temperature (°C)
	1	2	3	Average	
1					
2					
3					

## Annex C (normative)

### Determination of the external surface area of absorber tube for double-glass evacuated tubes

#### C.1 Equations of external surface area of absorber tube of double-glass evacuated tube

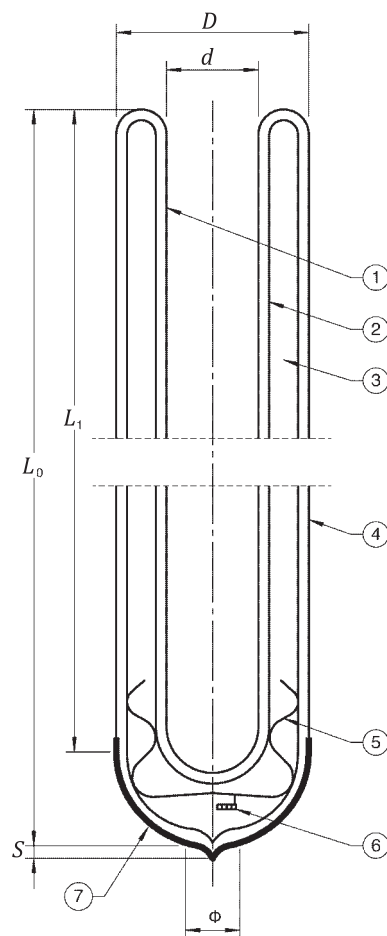

#### Key

1	inner glass tube (absorber tube)	$D$	outer diameter of envelope glass tube
2	solar selective absorbing coating	$d$	outer diameter of inner glass tube
3	vacuum jacket	$L_0$	length of evacuated tube
4	envelope glass tube	$L_1$	length of the part of inner tube which is exposed to sun
5	supporting part	$S$	length of sealing section
6	evaporable getter	$\Phi$	diameter of sealing section
7	getter mirror		

Figure C.1 — External surface area of absorber tube of double-glass evacuated tube

$$A_A = \pi \cdot d \cdot L_1 \cdot 10^{-6} \tag{C.1}$$

where

$A_A$  is the external surface area of absorber tube of double-glass evacuated tube, m<sup>2</sup>;

$d$  is the outer diameter of inner glass tube, mm;

$L_1$  is the length of the part of inner tube which is exposed to sun, mm.

**Table C.1 — External surface area  $A_A$  of absorber tube (m<sup>2</sup>)**

Outer diameter (mm)		Length of evacuated tube (mm)			
Envelope tube	Absorber tube	1 200	1 500	1 800	2 100
47	37	0,136	0,171	0,205	—
58	47	—	0,216	0,260	0,303

NOTE The prefilled values are only exemplary.



## Bibliography

- [1] ISO 9806, *Solar energy — Solar thermal collectors — Test methods*
- [2] GB/T 17049 - 2005 All-glass evacuated solar collector tubes
- [3] GB/T 19775 - 2005 Glass-metal sealed heat-pipe evacuated solar collector tubes

