**Industrial trucks — Verification of
stability —**

Part 4:

**Pallet stackers, double stackers and
order-picking trucks with operator
position elevating up to and including
1 200 mm lift height**

Chariots de manutention — Vérification de la stabilité —

Partie 4: Chariots à fourche recouvrante, chariots préparateurs de commandes avec un poste de l'opérateur ayant une hauteur de levée inférieure ou égale à 1 200 mm et chariots à double fourche



PDF disclaimer

This PDF file may contain embedded typefaces. In accordance with Adobe's licensing policy, this file may be printed or viewed but shall not be edited unless the typefaces which are embedded are licensed to and installed on the computer performing the editing. In downloading this file, parties accept therein the responsibility of not infringing Adobe's licensing policy. The ISO Central Secretariat accepts no liability in this area.

Adobe is a trademark of Adobe Systems Incorporated.

Details of the software products used to create this PDF file can be found in the General Info relative to the file; the PDF-creation parameters were optimized for printing. Every care has been taken to ensure that the file is suitable for use by ISO member bodies. In the unlikely event that a problem relating to it is found, please inform the Central Secretariat at the address given below.



COPYRIGHT PROTECTED DOCUMENT

© ISO 2009

All rights reserved. Unless otherwise specified, no part of this publication may be reproduced or utilized in any form or by any means, electronic or mechanical, including photocopying and microfilm, without permission in writing from either ISO at the address below or ISO's member body in the country of the requester.

ISO copyright office
Case postale 56 CH-1211 Geneva 20
Tel. + 41 22 749 01 11
Fax + 41 22 749 09 47
E-mail copyright@iso.org
Web www.iso.org

Published in Switzerland

Foreword

ISO (the International Organization for Standardization) is a worldwide federation of national standards bodies (ISO member bodies). The work of preparing International Standards is normally carried out through ISO technical committees. Each member body interested in a subject for which a technical committee has been established has the right to be represented on that committee. International organizations, governmental and non-governmental, in liaison with ISO, also take part in the work. ISO collaborates closely with the International Electrotechnical Commission (IEC) on all matters of electrotechnical standardization.

International Standards are drafted in accordance with the rules given in the ISO/IEC Directives, Part 2.

The main task of technical committees is to prepare International Standards. Draft International Standards adopted by the technical committees are circulated to the member bodies for voting. Publication as an International Standard requires approval by at least 75 % of the member bodies casting a vote.

Attention is drawn to the possibility that some of the elements of this document may be the subject of patent rights. ISO shall not be held responsible for identifying any or all such patent rights.

ISO 22915-4 was prepared by Technical Committee ISO/TC 110, *Industrial trucks*, Subcommittee SC 2, *Safety of powered industrial trucks*.

This first edition of ISO 22915-4 partially revises ISO 5766:1990¹⁾, of which it constitutes a technical revision.

ISO 22915 consists of the following parts, under the general title *Industrial trucks — Verification of stability*:

Part 1: General

— *Part 2: Counterbalanced trucks with mast*

Part 3: Reach and straddle trucks

Part 4: Pallet stackers, double stackers and order-picking trucks with operator position elevating up to and including 1 200 mm lift height

— *Part 5: Single side loading trucks*

Part 7: Bidirectional and multidirectional trucks

Part 8: Additional stability test for trucks operating in the special condition of stacking with mast tilted forward and load elevated

Part 10: Additional stability test for trucks operating in the special condition of stacking with load laterally displaced by powered devices

Part 14: Rough-terrain variable reach trucks

Part 20: Additional stability test for trucks operating in the special condition of offset load, offset by utilization

Part 21: Order-picking trucks with operator position elevating above 1 200 mm

1) ISO 5766, *Pallet stackers and high-lift platform trucks — Stability tests*, remains applicable to high-lift platform trucks.

The following parts are under preparation:

Part 9: Counterbalanced trucks with mast handling freight containers of 6 m (20 ft) length and longer

— *Part 11: Industrial variable reach trucks*

Part 12: Industrial variable reach trucks handling freight containers of 6 m (20 ft) length and longer

Part 15: Counterbalanced trucks with articulated steering

— *Part 16: Pedestrian-propelled trucks*

Part 17: Burden and personnel carriers

Lateral and front-stacking trucks with elevating operator position are to form the subject of a future Part 22.

Industrial trucks — Verification of stability —

Part 4:

Pallet stackers, double stackers and order-picking trucks with operator position elevating up to and including 1 200 mm lift height

1 Scope

This part of ISO 22915 specifies tests for verifying the stability of

pallet stackers,

double stackers, and

order-picking trucks with an operator position elevating up to and including 1 200 mm lift height, measured from the ground to the floor of the platform.

It is applicable to these types of industrial truck, whether with tilting or non-tilting masts or fork arms, having a rated capacity up to and including 5 000 kg.

It is also applicable to such trucks operating under the same conditions when equipped with load-handling attachments and to order-picking trucks with an elevating operator's position up to and including 1 200 mm lift height when equipped with an additional load-lifting device(s).

2 Normative references

The following referenced documents are indispensable for the application of this document. For dated references, only the edition cited applies. For undated references, the latest edition of the referenced document (including any amendments) applies.

ISO 5053, *Powered industrial trucks — Terminology*

ISO 22915-1, *Industrial trucks — Verification of stability — Part 1: General*

3 Terms and definitions

For the purposes of this document, the terms and definitions given in ISO 5053 and ISO 22915-1 apply.

4 Test conditions

4.1 General

See ISO 22915-1.

4.2 Position of truck on the tilt table

4.2.1 Load and drive/steer axles

The load axle and the drive/steer axle are defined by Figure 1.

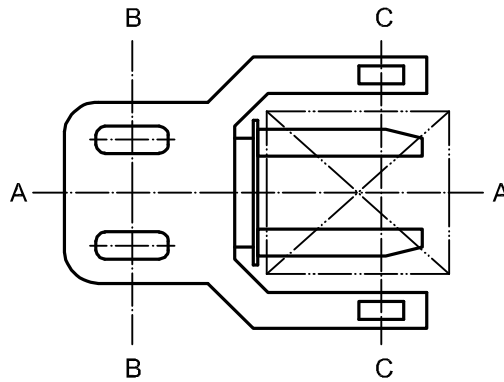

Key

- A-A longitudinal centre plane of truck
- B-B drive/steer axle
- C-C load axle

Figure 1 — Load and drive/steer axles

4.2.2 Tests 1, 2, 6, 7 and 8

The truck shall be positioned on the tilt table so that its drive/steer axle, B-B, and load axle, C-C, are parallel to the tilt axis, X-Y, of the tilt table. See Table 1.

4.2.3 Tests 3, 4, 5 and 9

The truck shall be positioned on the tilt table with the line, M-N, parallel to the tilt axis, X-Y, of the tilt table. See Table 1.

Point M is defined as follows:

- a) For trucks with a single non-articulating drive (steer) wheel: point M shall be the vertical projection onto the tilt table of the point of intersection between the centreline of the drive/steer axle and the centreline of the drive wheel width.
- b) For trucks with a drive/steer axle in an articulating frame articulated in the centre plane of the truck: point M shall be the vertical projection onto the tilt table of the point of intersection between the lateral axis of the articulating frame and the centre plane, A-A, of the truck.
- c) For trucks with a single or dual non-sprung castor wheel: point M shall be the vertical projection onto the tilt table of the point of intersection between the centreline of the castor wheel axle and the midpoint between the two castor wheels, with the non-sprung castor wheels being positioned parallel to X-Y.
- d) For trucks with a sprung castor wheel and a single non-sprung drive/steer wheel: point M shall be the vertical projection onto the tilt table of the point of intersection between the centreline of the drive-wheel axle and the centreline of the drive-wheel width, with the drive wheel positioned parallel to X-Y.

- e) For trucks with non-articulated dual drive/steer wheels: point M shall be the vertical projection onto the tilt table of the point of intersection between the centreline of the drive axle, B–B, and the centreline of the width of the drive wheel closest to X–Y, with the drive wheels positioned parallel to X–Y.
- f) For trucks with non-articulated, non-sprung chassis castors: point M shall be either
- 1) the vertical projection onto the tilt table of the point of intersection between the centreline of the castor wheel axles and the centreline of the castor wheel width, with the non-sprung castors positioned with the centreline of the castor wheel axles parallel to X–Y, and the castor wheels further away from X–Y, or
 - 2) the vertical projection onto the tilt table of the point of intersection between the centreline of the castor wheel width, with the non-sprung castor positioned so that the centreline of the castor wheel axle is parallel to and further away from X–Y.
- g) For trucks with a non-articulated, single drive wheel (steered) on the centre plane, A–A, and having sprung castor wheels: point M shall be the vertical projection onto the tilt table of the point of intersection between the centreline of the drive wheel axle and the centreline of the drive wheel width, with the axle of the drive wheel positioned at right angles to the tilt axis X–Y. The castor wheel axle closest to X–Y shall be positioned parallel to and further away from X–Y.

As shown in Table 1, point N is defined as the centre point of the area of contact between the tilt table surface and the load front wheel closest to the tilt axis, X–Y, of the tilt table.

4.3 Datum point positions

4.3.1 General

Test 1 shall be conducted with the horizontal position of the load datum point, E, unchanged when elevated from its lowered position as shown in Figure 2.

With the prescribed test load, set the mast vertical and then elevate to approximately 300 mm above the tilt table. With the shank of the front face of the fork arm set vertical, establish point E, as shown in Figure 2 a), on the fork arms or fork carrier having a fixed relationship to the centre of gravity of the test load. Point E shall be used to provide a reference datum point, F, on the tilt table. When the mast is elevated, a new point, F₁, on the tilt table may occur, as shown in Figure 2 b). This new point may be returned to the original location of F, as shown in Figure 2 c).

For trucks with tilting masts, changes in the location of F₁ may be corrected by varying the tilt of the mast within the limits provided by the design of the truck, as shown in Figure 2.

For trucks with non-tilting masts, the location of F₁ may be returned to the original location of F by adjusting the fork arms or fork carrier within the limits provided by the design of the truck.

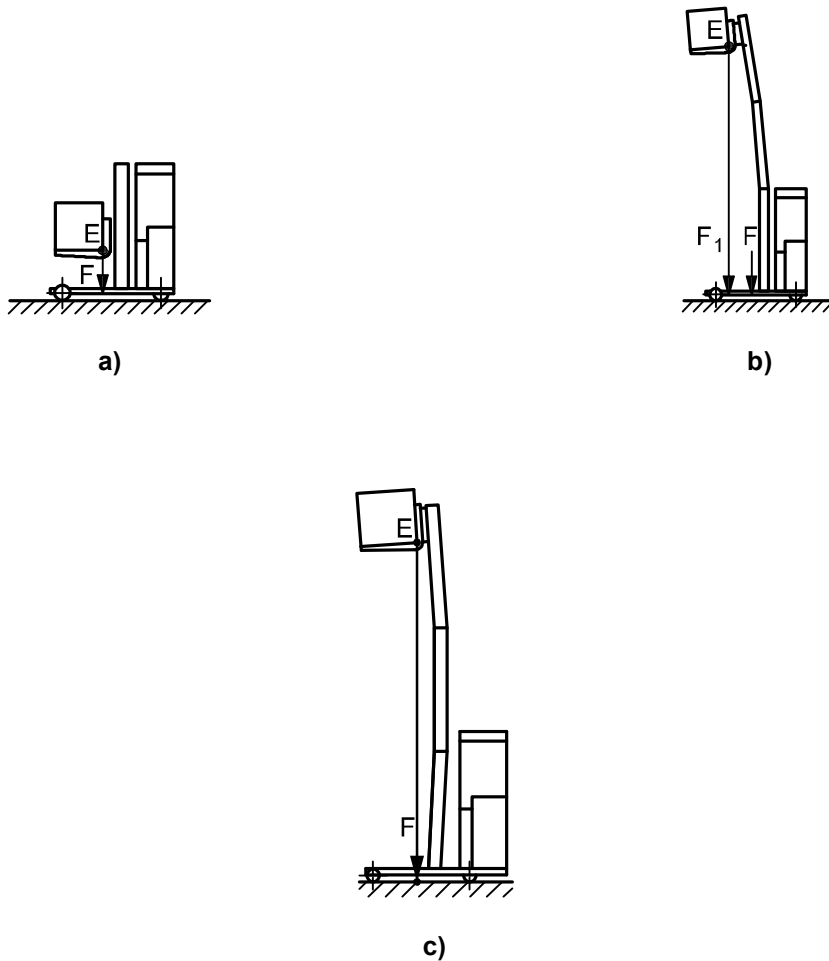

Figure 2 — Datum point positions

4.4 Lift height for tests simulating travel

For tests simulating travel (Tests 2, 4, 5, 7, 8 and 9), the upper face of the fork arms, measured at the heel of the fork arm, shall be positioned 300 mm above the tilt table or as close as possible to the outrigger, whichever is the higher.

4.5 Position of upper load when truck is used as double stacker

For trucks travelling with two loads, one load on the support arms and the other on the fork arms, the upper load shall be positioned so that the heel of the upper forks is at

- 1 100 mm from the load-bearing surface of the support arms, for trucks intended for a standard load distance of 500 mm,
- 1 300 mm from the load-bearing surface of the support arms, for trucks intended for a standard load distance of 600 mm.

5 Verification of stability

The stability of a truck shall be verified in accordance with Table 1.

Table 1 — Verification of stability

Test criteria	Test 1	Test 2	Test 3 ^b	Test 4 ^{b, d}	Test 5 ^b	Test 6	Test 7 ^{e, f}	Test 8 ^b	Test 9 ^{b, e, h}
Direction of test	Longitudinal	X				X	X	X	
	Lateral		X	X	X				X
Direction of load-handling device	Load leading	X	X				X		
	Load trailing					X	X	X	
Mode of operation	Travelling		X	X	X		X	X	X
	Stacking/retrieving	X		X		X			
Load at load centre	With	X	X	X		X	X		X
	Without				X			X	
Lift height	Maximum	X	X	X		X			
	Travel		X	X	X		g	X	X
Position of mast	Vertical	X					X		
	Full rearward		X			X		X	
Tilt-table angle	4 %		18 %	(2 + 0,3 <i>v</i>) % min. 3,5 % max. 6 %	(2 + 0,6 <i>v</i>) % for <i>v</i> ≤ 6 km/h max. 6 % (2 + 0,7 <i>v</i>) % for <i>v</i> > 6 km/h max. 7 %	10 %	(4 + 1,24 <i>v</i>) % see NOTE 1 or (8 + 1,24 <i>v</i>) % see NOTE 2	(10 + 0,5 <i>i</i> + 1,1 <i>v</i>) % for <i>v</i> ≤ 10 km/h (21 + 0,5 <i>i</i>) % for <i>v</i> > 10 km/h max. 26 %	(6 + 1,24 <i>v</i>) %
	<i>i</i> is the maximum gradient, expressed as a percentage, on which the unladen truck is designed to travel. <i>v</i> is the maximum travel speed of the unladen truck, in km/h.								
Truck position on tilt table									

Table 1 (continued)

Test criteria	Tests 1, 2, 6, 7 and 8
<p>Truck position on tilt table</p>	<div style="display: flex; justify-content: space-around;"> <div style="text-align: center;">  </div> <div style="text-align: center;">  </div> </div> <p>Key</p> <ul style="list-style-type: none"> 1 steer/drive axle B-B (any position) 2 non-articulated, non-sprung castors (any position) <p>As per 4.2.2 — Tests 1, 2 and 7</p>
	<div style="display: flex; justify-content: space-around;"> <div style="text-align: center;">  </div> <div style="text-align: center;">  </div> </div> <p>Key</p> <ul style="list-style-type: none"> 1 steer/drive axle B-B 2 non-articulated, non sprung castors <p>Also applicable to 4.2.3 f) 1) — Tests 3, 4, 5 and 9 (points M and N)</p> <p>As per 4.2.2 — Tests 6 and 8</p>

Table 1 (continued)

Test criteria	Tests 3, 4, 5 and 9 (points M and N)			
<p>Truck position on tilt table</p>				
	As per 4.2.3 a)	As per 4.2.3 b)	As per 4.2.3 c)	
	<p>Key</p> <ul style="list-style-type: none"> 1 drive/steer wheel parallel to X-Y 2 non-sprung castor (any position) 3 non-sprung castor wheel axle parallel to X-Y 4 non-sprung castor wheel turned towards truck centre plane 5 articulated frame 			

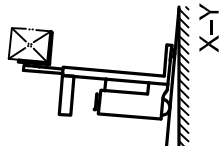
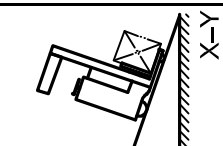
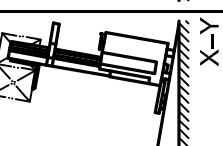
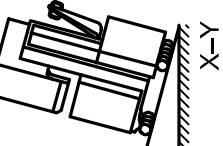
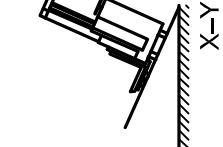
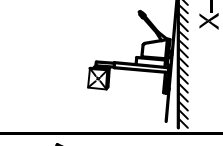
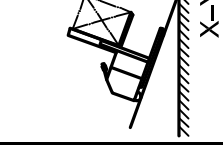
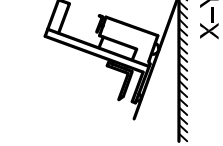
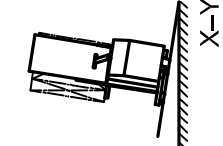
Table 1 (continued)

Test criteria	Tests 3, 4, 5 and 9 (points M and N)			
<p>Truck position on tilt table</p>				
	As per 4.2.3 d)	As per 4.2.3 e)	As per 4.2.3 f) 2)	As per 4.2.3 g)
<p>NOTE 1 Required slope when load leading. NOTE 2 Required slope when load trailing.</p> <p>a Parallel. b In Tests 3, 4, 5, 8 and 9, if the truck is equipped with a device that automatically limits the travel speed when the fork arms are elevated, this reduced speed shall be used when determining the angle of the tilt table. c For Tests 3, 4 and 5, when the truck is equipped with a tilting mast or tilting fork arms, these shall be positioned so that the truck is at its least stable. d Test 4 is for double stackers carrying two loads. e Tests 7 and 9 are for order-picking trucks only. f If the operator position can be elevated, it shall be at its maximum height. g Any attainable combination of lift height, load and travel speed that produces the least tilt table angle value for a given tilt table angle requirement is permitted. Travel speed v may be zero. h If the truck is equipped with a device that automatically limits the travel speed when the operator position is elevated, this reduced speed shall be used when determining the angle of the tilt table.</p>	<p>Key</p> <p>1 drive/steer wheel parallel to X-Y 2 non-sprung castor (any position) 3 non-sprung castor wheel axle parallel to X-Y 4 non-sprung castor wheel turned towards truck centre plane 5 articulated frame</p>	<p>6 sprung castor wheel axle parallel to X-Y 7 non-articulated, non-sprung castor wheel axle turned parallel to X-Y 8 drive/steer wheel (any position) 9 drive/steer wheel axle parallel to X-Y</p>		

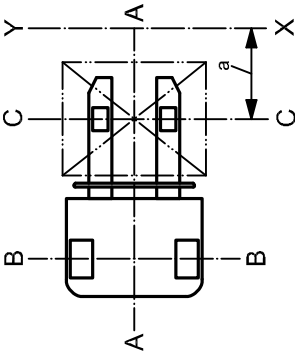
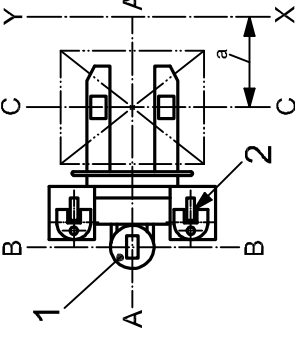
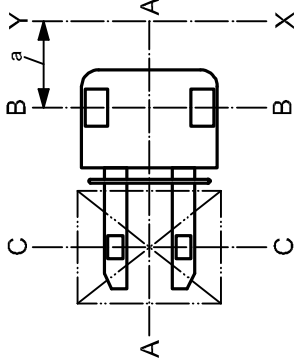
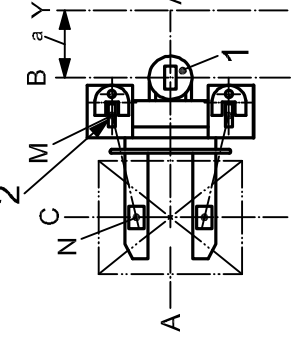
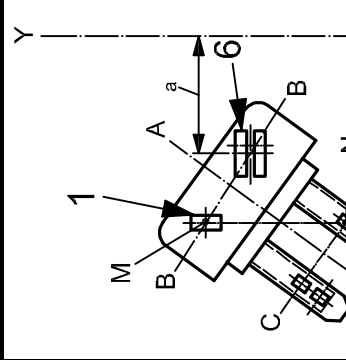
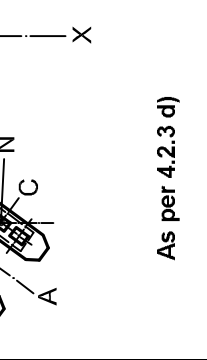
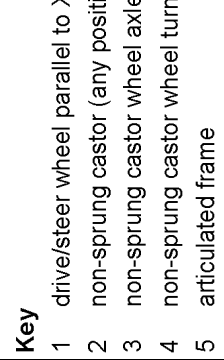
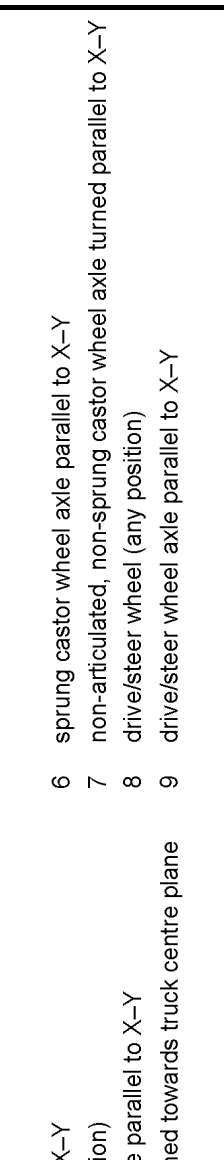