**Industrial trucks — Verification of
stability —**

**Part 3:
Reach and straddle trucks**

*Chariots de manutention — Vérification de la stabilité —
Partie 3: Chariots à mât ou à fourche rétractable*





COPYRIGHT PROTECTED DOCUMENT

© ISO 2014

All rights reserved. Unless otherwise specified, no part of this publication may be reproduced or utilized otherwise in any form or by any means, electronic or mechanical, including photocopying, or posting on the internet or an intranet, without prior written permission. Permission can be requested from either ISO at the address below or ISO's member body in the country of the requester.

ISO copyright office
Case postale 56 • CH-1211 Geneva 20
Tel. + 41 22 749 01 11
Fax + 41 22 749 09 47
E-mail copyright@iso.org
Web www.iso.org

Published in Switzerland

Contents

| | Page |
|---|----------|
| Foreword | iv |
| 1 Scope | 1 |
| 2 Normative references | 1 |
| 3 Terms and definitions | 1 |
| 4 Test conditions | 1 |
| 4.1 General | 1 |
| 4.2 Position of truck on tilt table | 1 |
| 4.3 Datum point positions | 3 |
| 4.4 Lift height for tests simulating travel | 4 |
| 5 Verification of stability | 4 |

.....

Foreword

ISO (the International Organization for Standardization) is a worldwide federation of national standards bodies (ISO member bodies). The work of preparing International Standards is normally carried out through ISO technical committees. Each member body interested in a subject for which a technical committee has been established has the right to be represented on that committee. International organizations, governmental and non-governmental, in liaison with ISO, also take part in the work. ISO collaborates closely with the International Electrotechnical Commission (IEC) on all matters of electrotechnical standardization.

The procedures used to develop this document and those intended for its further maintenance are described in the ISO/IEC Directives, Part 1. In particular the different approval criteria needed for the different types of ISO documents should be noted. This document was drafted in accordance with the editorial rules of the ISO/IEC Directives, Part 2. www.iso.org/directives

Attention is drawn to the possibility that some of the elements of this document may be the subject of patent rights. ISO shall not be held responsible for identifying any or all such patent rights. Details of any patent rights identified during the development of the document will be in the Introduction and/or on the ISO list of patent declarations received. www.iso.org/patents

Any trade name used in this document is information given for the convenience of users and does not constitute an endorsement.

For an explanation on the meaning of ISO specific terms and expressions related to conformity assessment, as well as information about ISO's adherence to the WTO principles in the Technical Barriers to Trade (TBT) see the following URL: Foreword - Supplementary information

The committee responsible for this document is ISO/TC 110, *Industrial trucks*, Subcommittee SC 2, *Safety of industrial trucks*.

This second edition cancels and replaces the first edition (ISO 22915-3:2008), of which it constitutes a minor revision.

ISO 22915 consists of the following parts, under the general title *Industrial Trucks — Verification of stability*:

- *Part 1: General*
- *Part 2: Counterbalanced trucks with mast*
- *Part 3: Reach and straddle trucks*
- *Part 4: Pallet stackers, double stackers and order-picking trucks with operator position elevating up to and including 1 200 mm lift height*
- *Part 5: Single-side-loading trucks*
- *Part 7: Bidirectional and multidirectional trucks*
- *Part 8: Additional stability test for trucks operating in the special condition of stacking with mast tilted forward and load elevated*
- *Part 9: Counterbalanced trucks with mast handling freight containers of 6 m (20 ft) length and longer*
- *Part 10: Additional stability test for trucks operating in the special condition of stacking with load laterally displaced by powered devices*
- *Part 11: Industrial variable-reach trucks*
- *Part 12: Industrial variable-reach trucks handling freight containers of 6 m (20 ft) length and longer*
- *Part 13: Rough-terrain trucks with mast*

- *Part 14: Rough-terrain variable-reach trucks*
- *Part 15: Counterbalanced trucks with articulated steering*
- *Part 16: Pedestrian-propelled trucks*
- *Part 20: Additional stability test for trucks operating in the special condition off offset load, offset by utilization*
- *Part 21: Order-picking trucks with operator position elevating above 1 200 mm*
- *Part 22: Lateral- and front- stacking trucks with and without elevating operator position*

The following parts are under preparation:

- *Part 24: Slewing variable-reach trucks*

Industrial and RTT lorry-mounted trucks are to form the subject of a future part 23.

Copyright International Organization for Standardization

Industrial trucks — Verification of stability —

Part 3: Reach and straddle trucks

1 Scope

This part of ISO 22915 specifies the tests for verifying the stability of reach trucks (with retractable mast or fork) and straddle trucks, equipped with tilting or non-tilting masts or fork arms and having a rated capacity up to and including 5 000 kg.

It is also applicable to such trucks operating under the same conditions when equipped with load-handling attachments.

2 Normative references

The following documents, in whole or in part, are normatively referenced in this document and are indispensable for its application. For dated references, only the edition cited applies. For undated references, the latest edition of the referenced document (including any amendments) applies.

ISO 5053, *Powered industrial trucks — Terminology*

ISO 22915-1, *Industrial trucks — Verification of stability — Part 1: General*

3 Terms and definitions

For the purposes of this document, the terms and definitions given in ISO 5053 and ISO 22915-1 apply.

4 Test conditions

4.1 General

See ISO 22915-1.

4.2 Position of truck on tilt table

4.2.1 Load and drive/steer axles

The load and drive/steer axles are defined by [Figure 1](#).

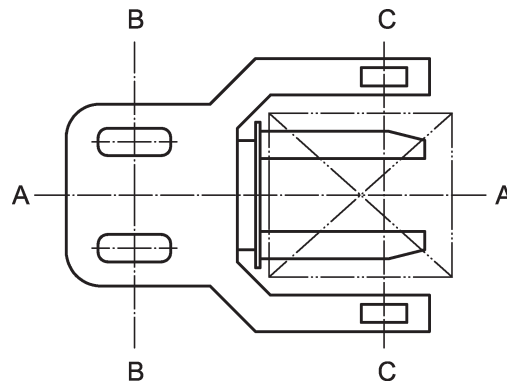

Key

- A-A longitudinal centre plane of truck
- B-B drive/steer axle
- C-C load axle

Figure 1 — Load and drive/steer axles

4.2.2 Tests 1, 2, 6, 7 and 8

The truck shall be positioned on the tilt table so that its drive/steer axle, B-B, and load axle, C-C, are parallel to the tilt axis, X-Y, of the tilt table. See [Table 1](#).

4.2.3 Tests 3, 4 and 5

The truck shall be positioned on the tilt table with the line, M-N, parallel to the tilt axis, X-Y, of the tilt table. See [Table 1](#).

Point M is defined as follows.

- a) **For trucks with a single non-articulating drive (steer) wheel:** point M shall be the vertical projection onto the tilt table of the point of intersection between the centreline of the drive/steer axle and the centreline of the drive wheel width.
- b) **For trucks with a non-sprung castor wheel point:**
 - 1) for tests carried out on the castor wheel side of the truck, point M shall be the vertical projection onto the tilt table of the point of intersection between the centreline of the castor wheel axle and the midpoint between the castor wheel or the two castor wheels, with the non-sprung castor being positioned with the centreline of the castor wheel axle nearer to the centre plane of the truck;
 - 2) for tests carried out on the drive (steer) wheel side of the truck, point M shall be the vertical projection onto the tilt table of the point of intersection between the centreline of the drive/steer axle and the centreline of the drive wheel width.
- c) **For trucks with a drive/steer axle in an articulating frame articulated in the centre plane of the truck:** point M shall be the vertical projection onto the tilt table of the point of the intersection between the lateral axis of the articulating frame and the centre plane, A-A, of the truck.
- d) **For trucks with a sprung castor wheel and a single non-sprung drive (steer) wheel:** point M shall be the vertical projection onto the tilt table of the point of intersection between the centreline of the drive wheel axle and the centreline of the drive wheel width, with the axle of the drive wheel positioned at right angles to the tilt axis.
- e) **For trucks with non-articulated dual drive (steer) wheels in pivoting mounting:** point M shall be the vertical projection onto the tilt table of the point of intersection between the centreline of the

drive axle and the centreline of the width of the drive wheel closer to the tilt axis, with the axle of the drive wheels positioned at right angles to the tilt axis.

- f) **For trucks with non-articulated, non-sprung chassis castors:** point M shall be the vertical projection onto the tilt table of the point of intersection between the centreline of the castor wheel width, with the non-sprung castor positioned with the centreline of the castor wheel axle nearer to the centre plane of the truck.
- g) **For trucks with a non-articulated, single-drive wheel (steered) on the centre plane, A-A, and sprung castor wheels:** point M shall be the vertical projection onto the tilt table of the point of intersection between the centreline of the drive wheel axle and the centreline of the drive wheel width, with the axle of the drive wheel positioned at right angles to the tilt axis. The castor wheel closest to the tilt axis shall be positioned at right angles to the tilt axis and the castor wheel axle shall be nearer to the centre plane of the truck.

As shown in [Table 1](#), point N is defined as the centre point of the area of contact between the tilt table surface and the load front wheel closest to the tilt axis, X-Y, of the tilt table.

4.3 Datum point positions

4.3.1 General

Test 1 may be conducted with the horizontal position of the load datum point, E, unchanged when elevated from its lowered position as shown in [Figure 2](#).

With the prescribed test load, set the mast vertical and then elevate to approximately 300 mm above the tilt table. With the shank of the front face of the fork arm set vertical, establish point E, as shown in [Figure 2 a\)](#) and b), on the fork arms or fork carrier having a fixed relationship to the centre of gravity of the test load. Point E shall be used to provide a reference datum point, F, on the tilt table. When the mast is elevated, a new point, F₁, on the tilt table may occur, as shown in [Figure 2 c\)](#) and d). This new point may be returned to the original location of F, as shown in [Figure 2 e\)](#) and f).

For trucks with tilting masts, changes in the location of F₁ may be corrected by varying the tilt of the mast within the limits provided by the design of the truck. See [Figure 2 a\), c\)](#) and e).

For trucks with non-tilting masts, the location of F₁ is subject to regional requirements.

4.3.2 Regional requirements for trucks with non-tilting masts

4.3.2.1 North America and Australia

The location of F₁ shall not be corrected. Only correction by varying the mast tilt is permissible.

4.3.2.2 All other regions

Adjustments in the fork arms or fork carrier tilt, fork carrier retraction (where provided) or retraction of the mast may be used to correct for changes in the location of point F₁, within the limits provided by the design of the truck. See [Figure 2 b\), d\)](#) and f).

4.4 Lift height for tests simulating travel

For tests simulating travel (Tests 2, 5 and 8), the upper face of the fork arms, measured at the heel of the fork arm, shall be positioned 300 mm above the tilt table.

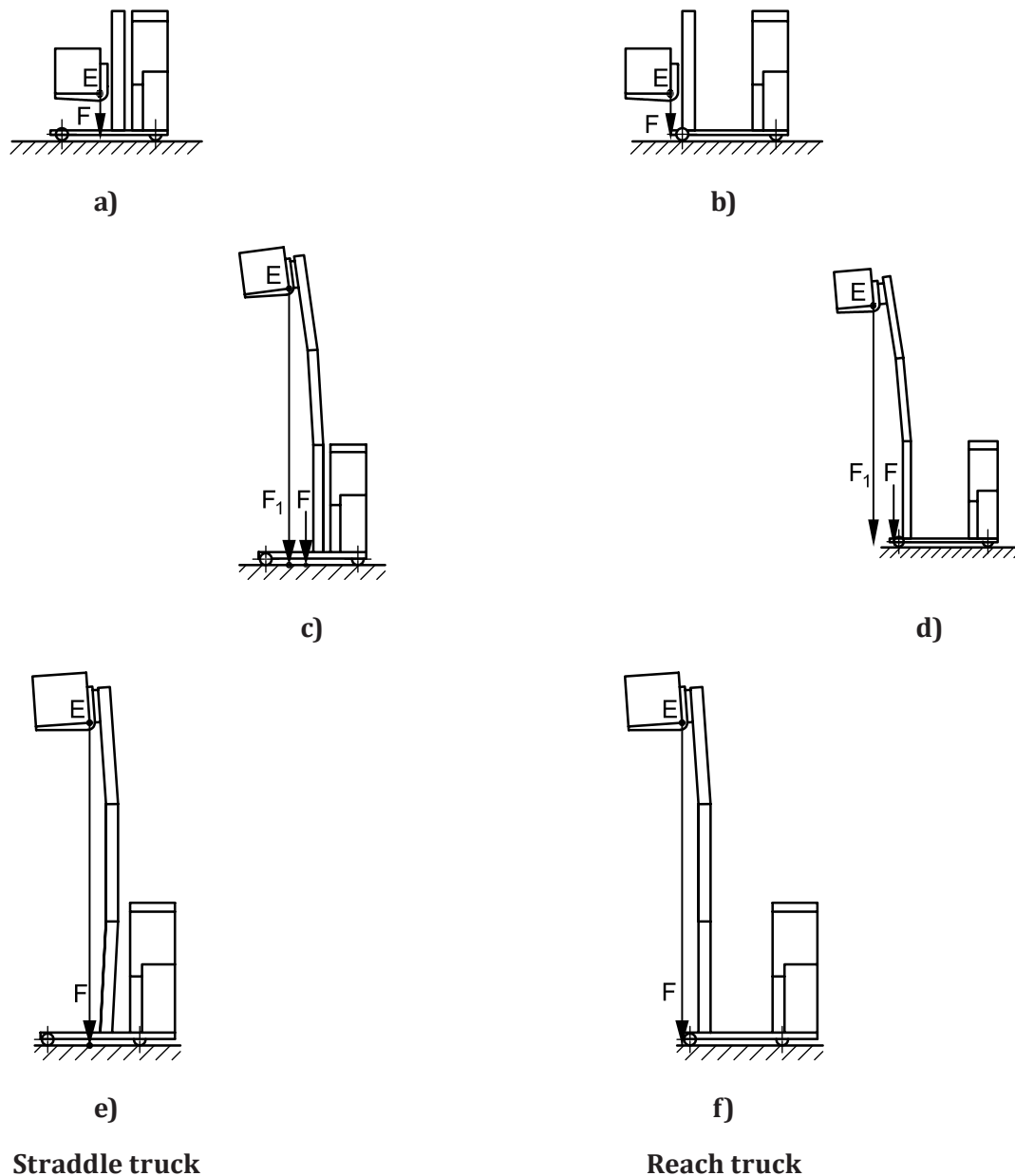

Figure 2 — Datum point positions

5 Verification of stability

The stability of a truck shall be verified in accordance with Table 1.

Table 1 — Verification of stability

| Test criteria | Test 1 | Test 2 | Test 3 | Test 4 | Test 5 | Test 6 | Test 7 | Test 8 |
|--|---|---|--|--|--|--|--------|---|
| Direction of test | | | | | | | | |
| Longitudinal | x | x | | | | x | x | x |
| Lateral | | | x | x | x | | | |
| Direction of load-handling device | | | | | | | | |
| Load leading | x | x | | | | | | |
| Load trailing | | | | | | x | x | x |
| Mode of operation | | | | | | | | |
| Travelling | | x | | | x | | | x |
| Stacking/retrieving | x | | x | x | | x | x | |
| With | x | x | x | | | x | | |
| Without | | | | x | x | | x | x |
| Load at load centre | | | | | | | | |
| Maximum | x | | x | x | | x | x | |
| Travel | | x | | | x | | | x |
| Position of load-carrying device | | | | | | | | |
| Extendable | x ^a | | | | | | | |
| Retractable | | x | x | x | x | x | x | x |
| Position of mast | | | | | | | | |
| Vertical | x | | b | b | b | | | |
| Full rearward | | x | b | b | b | | | |
| Tilt table angle | | | | | | | | |
| | 4 % | 18 % | 6 % | 8 % | (15 + 1,1 <i>v</i>) % or 50 % max. | 14 % | 14 % | (15 + 0,5 <i>i</i> + 1,55 <i>v</i>) % (40 + 0,5 <i>i</i>) % max. |
| Truck position on tilt table |  |  |  |  |  |  | | |
| 1 Position for straddle trucks | v Maximum travel speed of unladen truck, km/h | | | | | | | |
| 2 Extended (for reach trucks) | i Maximum gradient, expressed as a percentage, on which unladen truck is designed to travel | | | | | | | |

Table 1 — (continued)



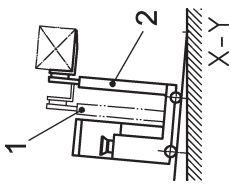
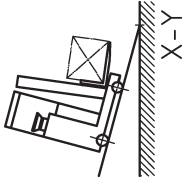
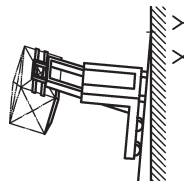
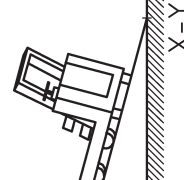
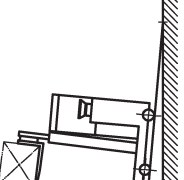
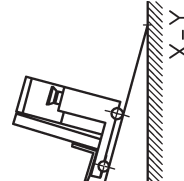

| Test criteria | Tests 1, 2, 6, 7 and 8 |
|------------------------------|---|
| Truck position on tilt table | <div style="display: flex; justify-content: space-around;"> <div style="text-align: center;">  </div> <div style="text-align: center;">  </div> </div> <p style="text-align: center;">As per 4.2.2.2 — Tests 1 and 2</p> <div style="display: flex; justify-content: space-around;"> <div style="text-align: center;">  </div> <div style="text-align: center;">  </div> </div> <p style="text-align: center;">As per 4.2.2.2 — Tests 6, 7 and 8</p> <div style="display: flex; justify-content: space-between;"> <div style="width: 45%;"> <p>1 Articulated steering and driving axle (any wheel position permitted in test)</p> <p>2 Non-articulated, non-sprung castors (any wheel position permitted in test)</p> </div> <div style="width: 45%;"> <p>3 Non-articulated, non-sprung castors turned towards load</p> <p>4 Articulated steering and driving axle (longitudinal direction)</p> </div> </div> |

Table 1 — (continued)

| Test criteria | Tests 3, 4 and 5 (points M and N) | | | |
|--|--|--|---|---|
| Truck position on tilt table |  <p>As per 4.2.3 a)</p> |  <p>As per 4.2.3 d)</p> |  <p>As per 4.2.3 b) 1)</p> |  <p>As per 4.2.3 b) 2)</p> |
| |  <p>As per 4.2.3 e)</p> |  <p>As per 4.2.3 f)</p> | | |
| 1 Non-sprung castor | 3 Non-articulated, non-sprung castor turned towards truck centreline | | | |
| 2 Support wheel sprung castor | 4 Sprung castor turned towards truck centreline | | | |
| a For reach trucks only. | | | | |
| b When the truck is equipped with a tilting mast or tilting fork arms, these shall be positioned so that the truck is at its least stable. | | | | |
| c Parallel. | | | | |
| d Any position. | | | | |

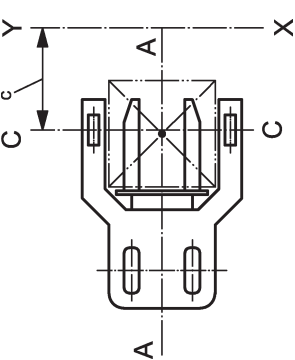
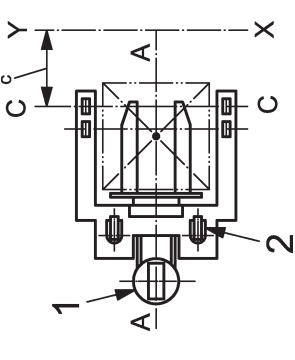
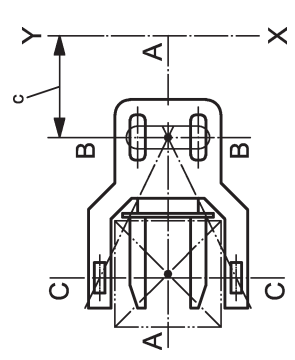
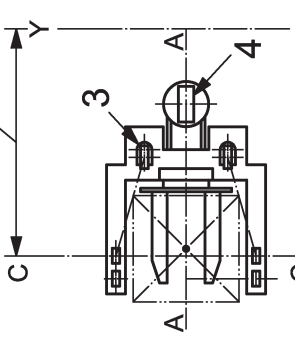
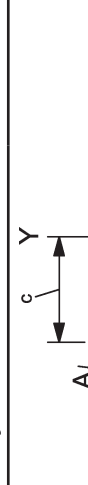
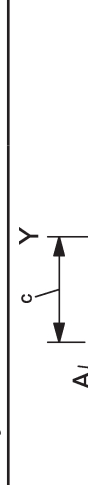
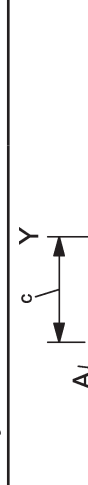
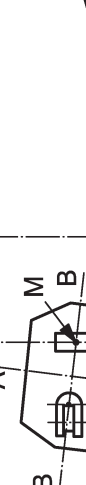