

---

---

**Industrial trucks — Verification of  
stability —**

**Part 22:  
Lateral- and front-stacking trucks  
with and without elevating operator  
position**

*Chariots de manutention — Vérification de la stabilité —*

*Partie 22: Chariots à prise latérale - et frontale - avec et sans poste de  
conduite élevable*



Reference number  
ISO 22915-22:2014(E)

© ISO 2014



**COPYRIGHT PROTECTED DOCUMENT**

© ISO 2014

All rights reserved. Unless otherwise specified, no part of this publication may be reproduced or utilized otherwise in any form or by any means, electronic or mechanical, including photocopying, or posting on the internet or an intranet, without prior written permission. Permission can be requested from either ISO at the address below or ISO's member body in the country of the requester.

ISO copyright office  
Case postale 56 • CH-1211 Geneva 20  
Tel. + 41 22 749 01 11  
Fax + 41 22 749 09 47  
E-mail [copyright@iso.org](mailto:copyright@iso.org)  
Web [www.iso.org](http://www.iso.org)

Published in Switzerland

# Contents

	Page
<b>Foreword</b> .....	<b>iv</b>
<b>1 Scope</b> .....	<b>1</b>
<b>2 Normative references</b> .....	<b>1</b>
<b>3 Terms and definitions</b> .....	<b>1</b>
<b>4 Test conditions</b> .....	<b>2</b>
4.1 General .....	2
4.2 Position of the truck on tilt table .....	2
4.3 Lift height .....	3
<b>5 Verification of stability</b> .....	<b>3</b>
<b>Bibliography</b> .....	<b>10</b>

## Foreword

ISO (the International Organization for Standardization) is a worldwide federation of national standards bodies (ISO member bodies). The work of preparing International Standards is normally carried out through ISO technical committees. Each member body interested in a subject for which a technical committee has been established has the right to be represented on that committee. International organizations, governmental and non-governmental, in liaison with ISO, also take part in the work. ISO collaborates closely with the International Electrotechnical Commission (IEC) on all matters of electrotechnical standardization.

The procedures used to develop this document and those intended for its further maintenance are described in the ISO/IEC Directives, Part 1. In particular the different approval criteria needed for the different types of ISO documents should be noted. This document was drafted in accordance with the editorial rules of the ISO/IEC Directives, Part 2 (see [www.iso.org/directives](http://www.iso.org/directives)).

Attention is drawn to the possibility that some of the elements of this document may be the subject of patent rights. ISO shall not be held responsible for identifying any or all such patent rights. Details of any patent rights identified during the development of the document will be in the Introduction and/or on the ISO list of patent declarations received (see [www.iso.org/patents](http://www.iso.org/patents)).

Any trade name used in this document is information given for the convenience of users and does not constitute an endorsement.

For an explanation on the meaning of ISO specific terms and expressions related to conformity assessment, as well as information about ISO's adherence to the WTO principles in the Technical Barriers to Trade (TBT) see the following URL: Foreword - Supplementary information

The committee responsible for this document is ISO/TC 110, *Industrial trucks*, Subcommittee SC 2, *Safety of powered industrial trucks*.

ISO 22915 consists of the following parts, under the general title *Industrial trucks — Verification of stability*:

- *Part 1: General*
- *Part 2: Counterbalanced trucks with mast*
- *Part 3: Reach and straddle trucks*
- *Part 4: Pallet stackers, double stackers and order-picking trucks up to and including 1 200 mm lift height*
- *Part 5: Single-side-loading trucks*
- *Part 7: Bidirectional and multidirectional trucks*
- *Part 8: Additional stability test for trucks operating in the special condition of stacking with mast tilted forward and load elevated*
- *Part 9: Counterbalanced trucks with mast handling freight containers of 6 m (20 ft) length and longer*
- *Part 10: Additional stability test for trucks operating in the special condition of stacking with load laterally displaced by powered devices*
- *Part 11: Industrial variable-reach trucks*
- *Part 12: Industrial variable-reach trucks handling freight containers of 6 m (20 ft) length and longer*
- *Part 13: Rough-terrain trucks with mast*
- *Part 14: Rough-terrain variable-reach trucks*

- *Part 15: Counterbalanced trucks with articulated steering*
- *Part 16: Pedestrian-propelled trucks*
- *Part 20: Additional stability test for trucks operating in the special condition of offset load, offset by utilization*
- *Part 21: Order-picking trucks with operator position elevating above 1 200 mm*
- *Part 22: Lateral- and front-stacking trucks with and without elevating operator position*
- *Part 24: Slewing variable-reach rough-terrain trucks*

Industrial and RTT lorry-mounted trucks are to form the subject of a future part 23.



# Industrial trucks — Verification of stability —

## Part 22:

# Lateral- and front-stacking trucks with and without elevating operator position

## 1 Scope

This part of ISO 22915 specifies the tests to verify the stability of lateral- and front-stacking trucks, as defined in ISO 5053-1, with and without elevating operator position.

It applies to trucks fitted with fork arms, shuttle forks, and/or integrated attachments under normal operating conditions.

It applies to trucks fitted with a load carrier that can be shifted laterally or pivoted out of the longitudinal centre plane of the truck.

## 2 Normative references

The following documents, in whole or in part, are normatively referenced in this document and are indispensable for its application. For dated references, only the edition cited applies. For undated references, the latest edition of the referenced document (including any amendments) applies.

ISO 5053-1, *Powered industrial trucks — Terminology and classification — Part 1: Types of industrial trucks*

ISO 22915-1, *Industrial trucks — Verification of stability — Part 1: General*

## 3 Terms and definitions

For the purpose of this document, the terms and definitions given in ISO 22915-1 and the following apply

### 3.1

#### **normal operating condition**

operating condition corresponding to the truck travelling indoors on smooth, level floors of sufficient strength such as those of concrete

### 3.2

#### **guided steering**

steering mode, either mechanical (e.g. guidance rails) or non-mechanical (e.g. inductive guidance, laser sensor or infrared) not controlled directly by the operator, used to steer the truck on a predetermined straight path while travelling

### 3.3

#### **restricted steering**

operation under which the truck's steering is controlled by the operator and the steering angle is limited to not more than  $\pm 10^\circ$  from the forward or reverse travel direction

### 3.4

#### **unrestricted steering**

steering mode controlled by the operator with no limitation of the steering angle

## 4 Test conditions

### 4.1 General

See ISO 22915-1.

### 4.2 Position of the truck on tilt table

#### 4.2.1 Load and steer axles

The load axle and the drive/steer axle are defined by [Figure 1](#).

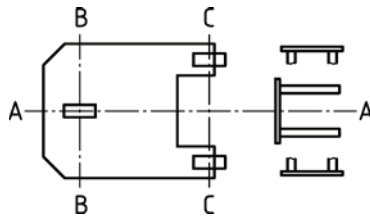

#### Key

- A-A longitudinal centre plane of truck
- B-B drive/steer axle
- C-C load axle

**Figure 1 — Load axle and drive/steer axle**

#### 4.2.2 Tests 1, 2 and 3

The truck shall be positioned on the tilt table with the drive (steer) axle B-B and the load axle C-C parallel to the tilt axis X-Y, of the tilt table. See [Table 1](#).

#### 4.2.3 Test 4

The truck shall be positioned on the tilt table with the longitudinal centre plane of truck A-A parallel to the tilt axis X-Y, of the tilt table. See [Table 1](#).

#### 4.2.4 Tests 5, 6 and 7

The truck shall be positioned on the tilt table with the line M-N parallel to the tilt axis X-Y, of the tilt table.

Point M is defined as follows:

- a) For trucks with dual drive (steer) wheels, point M is the vertical projection onto the tilt table of the point of intersection between the centre line of the drive axle and the centre plane of A-A of the truck.
- b) For trucks with a single drive (steer) wheel, point M is the vertical projection onto the tilt table of the point of intersection between the centre line of the drive (steer) axle and the centre line of the drive wheel width.
- c) For trucks with a sprung castor or wheel, point M is the vertical projection onto the tilt table of the point of intersection between the centre line of the drive wheel axle and the centre line of drive wheel width.
- d) For trucks with a drive (steer axle in an articulated frame), point M is the vertical projection onto the tilt table of the point of intersection between the lateral axis of the articulating frame and the point of articulation.



- e) For trucks with a non-articulated drive wheel, point M is the vertical projection onto the tilt table of the point of intersection between the centre line of the drive wheel axle and centre line of drive wheel width.
- f) For trucks with non-articulated, non-sprung castor or wheel point M is the vertical projection onto the tilt table of the point of intersection between the centre line of the castor or wheel axle and the centre line of the castor wheel or drive wheel width. The castor or wheel shall be positioned with the centre line of the castor wheel axle nearer to the centre plane of the truck.
- g) For trucks with five-wheel suspension, four solid and one articulated point M are the projection to the tilt table of the intersection of the pivot axis of the three-wheel articulated frame and the centre line between the tires.
- h) For trucks with centre-articulating frame steering, point M is the projection to the tilt table from the intersection of the centre line of the drive wheel axle and the centre line of the drive wheel width.

Point N indicates the centre point of the area of contact between the tilt table surface and the front-load wheel closest to the tilt axis X-Y of the tilt table.

### 4.3 Lift height

Lift heights for tests shall be measured from the tilt table to the upper most point of the load-carrying surface.

## 5 Verification of stability

The stability shall be verified according to [Table 1](#).

**Table 1 — Verification of stability of lateral- and front-stacking trucks with and without elevating operator position**

Test criteria	Test 1	Test 2	Test 3	Test 4	Test 5	Test 6	Test 7
<b>Direction</b>	Longitudinal, load leading	x					
	Longitudinal, load trailing		x				
	Lateral			x	x	x	x
<b>Test load</b>	With	x	x	x	x		
	Without	x	x			x	x
<b>Load carrier position</b>	Least stable side extended	x			x		
	Least stable transport		x		x	x	x
<b>Lift height</b>		b	b	c	d	d	e
	Guided steering	4 % <sup>f</sup> (4 + 0,62 · v) %	6 % <sup>g</sup> (0,28 + 1,43 · v) % <sup>h</sup>	8 % <sup>g</sup> (1,4 + 1,65 · v) % <sup>h</sup>	4 %	6 %	6 %
	Restricted steering						
Unrestricted steering							
<b>Tilt table angle</b>							
v maximum speed of truck, km/h							
a Parallel.							
b Any attainable combination of lift height, load, and corresponding maximum travel speed that produces the least tilt table angle value for a given tilt table angle requirement of Test 1 and Test 2. Travel speed v can be zero.							
c Any attainable combination of lift height and load that produces the least tilt table angle value for a given tilt table angle requirement.							
d Any attainable combination of lift height above 1 200 mm and corresponding maximum travel speed that produces the least tilt table angle value for a given tilt table angle requirement.							
e Lift height up to and including 1 200 mm.							
f Requirement for speed up to and including 2,5 km/h (see ISO 3691-3[1] for speed limits when lateral reach mechanism is extended, retracting, or retracting).							
g For travel speeds up to and including 4 km/h.							
h For travel speeds above 4 km/h.							

Table 1 — (continued)

Tests 1 and 2	
<p><b>Truck position on tilt table</b></p> <p>Load handling device is leading — Load carrying device extended</p>	 <p><b>Test 1 — As per 4.2.2</b></p>
<p>Load handling device is leading — Load carrying device in transport position</p>	 <p><b>Test 2 — As per 4.2.2</b></p>
<p>a Parallel.</p>	

Table 1 — (continued)

<p>Truck position on tilt table</p> <p>Load handling device is trailing —</p> <p>Load carrying device in transport position</p>	<p>Test 3</p> 	 <p>As per 4.2.2</p>
<p>a Parallel.</p>		

Table 1 — (continued)

Truck position on tilt table Lateral tests	Test 4	Test 5	Tests 6 and 7
			
a Parallel.			

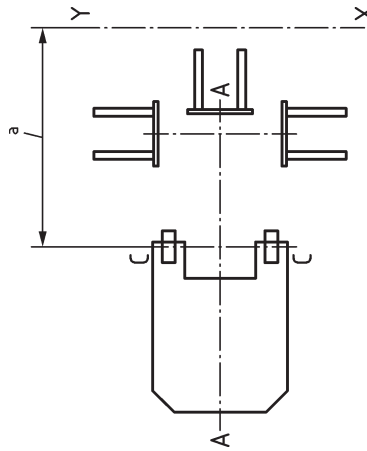
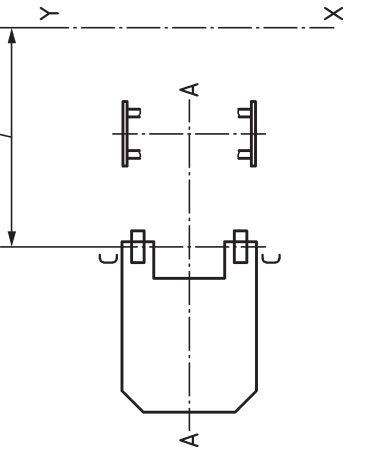
Table 1 — (continued)

Tests 5, 6 and 7			
Truck position on tilt table Points M and N	<p>As per 4.2.4 a)</p>	<p>As per 4.2.4 b)</p>	<p>As per 4.2.4 c)</p>
	<p>As per 4.2.4 d)</p>	<p>As per 4.2.4 e)</p>	<p>As per 4.2.4 f)</p>

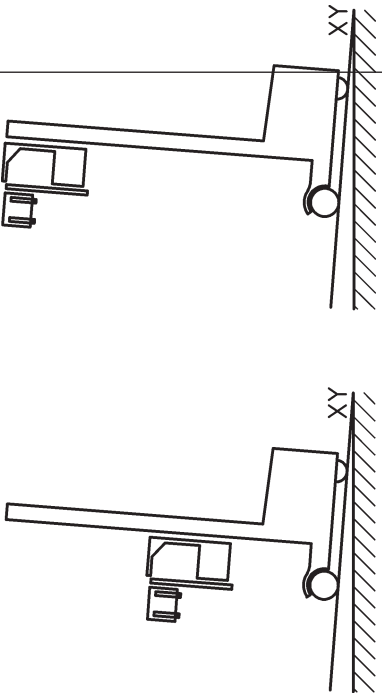
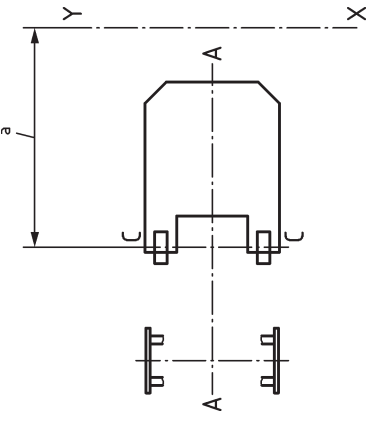
a Parallel.

Table 1 — (continued)

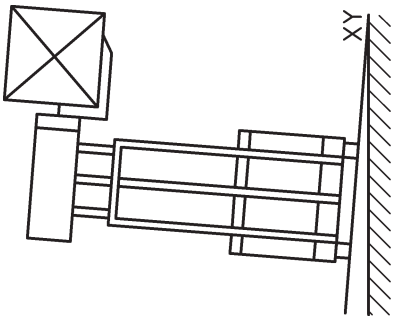
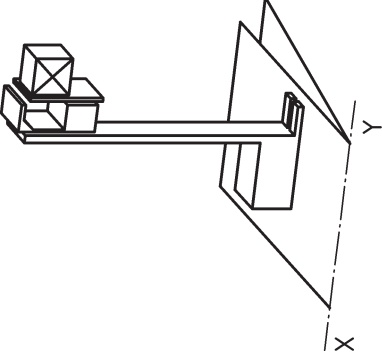
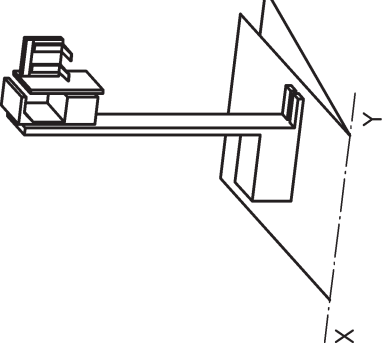
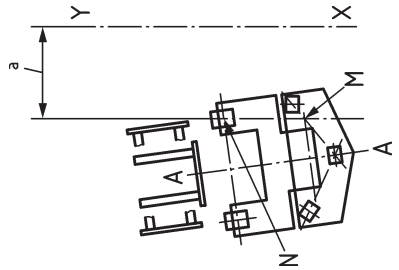
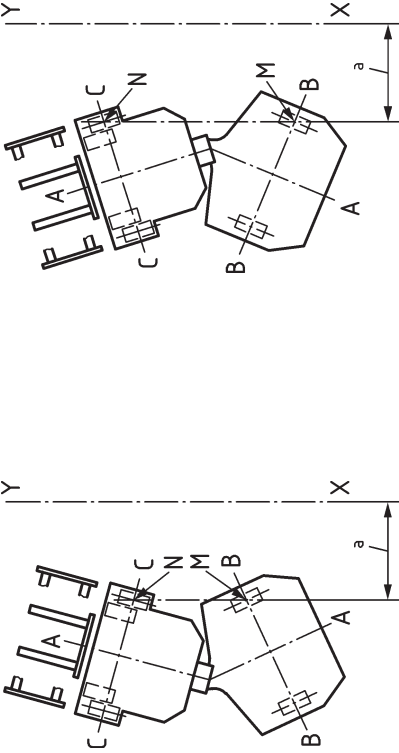
Truck position on tilt table	Tests 5, 6, and 7	
Points M and N	 <p data-bbox="715 1323 746 1503">As per 4.2.4 g)</p>	 <p data-bbox="715 607 746 786">As per 4.2.4 h)</p>
a Parallel.		

## Bibliography

- [1] ISO 3691-3, *Industrial trucks — Safety requirements and verification — Part 3: Additional requirements for trucks with elevating operator position and trucks specifically designed to travel with elevated loads*





