**Industrial trucks — Verification of
stability —**

**Part 2:
Counterbalanced trucks with mast**

Chariots de manutention — Vérification de la stabilité —

Partie 2: Chariots travaillant en porte-à-faux à mât



Reference number
ISO 22915-2:2008(E)

© ISO 2008

PDF disclaimer

This PDF file may contain embedded typefaces. In accordance with Adobe's licensing policy, this file may be printed or viewed but shall not be edited unless the typefaces which are embedded are licensed to and installed on the computer performing the editing. In downloading this file, parties accept therein the responsibility of not infringing Adobe's licensing policy. The ISO Central Secretariat accepts no liability in this area.

Adobe is a trademark of Adobe Systems Incorporated.

Details of the software products used to create this PDF file can be found in the General Info relative to the file; the PDF-creation parameters were optimized for printing. Every care has been taken to ensure that the file is suitable for use by ISO member bodies. In the unlikely event that a problem relating to it is found, please inform the Central Secretariat at the address given below.

.....



COPYRIGHT PROTECTED DOCUMENT

© ISO 2008

All rights reserved. Unless otherwise specified, no part of this publication may be reproduced or utilized in any form or by any means, electronic or mechanical, including photocopying and microfilm, without permission in writing from either ISO at the address below or ISO's member body in the country of the requester.

ISO copyright office
Case postale 56 • CH-1211 Geneva 20
Tel. + 41 22 749 01 11
Fax + 41 22 749 09 47
E-mail copyright@iso.org
Web www.iso.org

Published in Switzerland

Foreword

ISO (the International Organization for Standardization) is a worldwide federation of national standards bodies (ISO member bodies). The work of preparing International Standards is normally carried out through ISO technical committees. Each member body interested in a subject for which a technical committee has been established has the right to be represented on that committee. International organizations, governmental and non-governmental, in liaison with ISO, also take part in the work. ISO collaborates closely with the International Electrotechnical Commission (IEC) on all matters of electrotechnical standardization.

International Standards are drafted in accordance with the rules given in the ISO/IEC Directives, Part 2.

The main task of technical committees is to prepare International Standards. Draft International Standards adopted by the technical committees are circulated to the member bodies for voting. Publication as an International Standard requires approval by at least 75 % of the member bodies casting a vote.

Attention is drawn to the possibility that some of the elements of this document may be the subject of patent rights. ISO shall not be held responsible for identifying any or all such patent rights.

ISO 22915-2 was prepared by Technical Committee ISO/TC 110, *Industrial trucks*, Subcommittee SC 2, *Safety of powered industrial trucks*.

This first edition of ISO 22915-2 cancels and replaces ISO 1074:1991, of which it constitutes a technical revision.

ISO 22915 consists of the following parts, under the general title *Industrial trucks — Verification of stability*:

- *Part 1: General*
- *Part 2: Counterbalanced trucks with mast*
- *Part 3: Reach and straddle trucks*
- *Part 4: Pallet stackers, double stackers and order-picking trucks with operator position elevating up to and including 1 200 mm lift height*
- *Part 7: Bi-directional and multi-directional trucks*
- *Part 8: Additional stability test for trucks operating in the special condition of stacking with mast tilted forward and load elevated*
- *Part 10: Additional stability test for trucks operating in the special condition of stacking with load laterally displaced by powered devices*
- *Part 20: Additional stability test for trucks operating in the special condition of offset load, offset by utilization*
- *Part 21: Order-picking trucks with operator position elevating above 1 200 mm*

The following parts are under preparation:

- *Part 5: Single side loading trucks*
- *Part 9: Counterbalanced trucks with mast handling freight containers of 6 m (20 ft) length and longer*

ISO 22915-2:2008(E)

- *Part 11: Industrial variable reach trucks*
- *Part 12: Industrial variable reach trucks handling freight containers of 6 m (20 ft) length and longer*
- *Part 14: Rough-terrain variable reach trucks*
- *Part 15: Counterbalanced trucks with articulated steering*
- *Part 16: Pedestrian-propelled trucks*
- *Part 17: Burden and personnel carriers*

Industrial trucks — Verification of stability —

Part 2: Counterbalanced trucks with mast

1 Scope

This part of ISO 22915 specifies the tests for verifying the stability of counterbalanced trucks with masts, equipped with fork arms or with load handling attachments. It is not applicable to those trucks designed for handling freight containers, dealt with by ISO 22915-9¹⁾.

2 Normative references

The following referenced documents are indispensable for the application of this document. For dated references, only the edition cited applies. For undated references, the latest edition of the referenced document (including any amendments) applies.

ISO 5053, *Powered industrial trucks — Terminology*

ISO 22915-1, *Industrial trucks — Verification of stability — Part 1: General*²⁾

3 Terms and definitions

For the purposes of this document, the terms and definitions given in ISO 5053 and ISO 22915-1 apply.

4 Test conditions

4.1 General

See ISO 22915-1.

4.2 Position of truck on tilt table

4.2.1 Load and steer axles

The load and steer axles are defined by Figure 1.

1) Under preparation.

2) To be published.

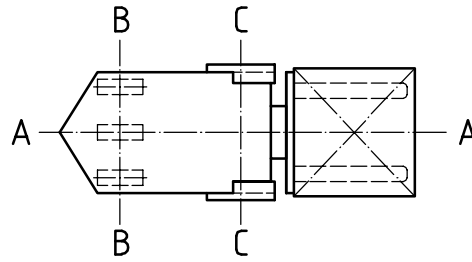

Key

- A-A longitudinal centre plane of truck
- B-B steer axle
- C-C load axle

Figure 1 — Load and steer axles

4.2.2 Tests 1 and 2

The truck shall be positioned on the tilt table so that its load axle, C-C, is parallel to the tilt axis, X-Y, of the tilt table. See Table 1.

4.2.3 Tests 3 and 4

The truck shall be positioned on the tilt table in a turning position with the line, M-N, parallel to the tilt axis, X-Y, of the tilt table.

As shown in Table 1, the steered wheel nearest to the tilt axis shall be parallel to X-Y. Point M is defined as follows.

- a) For trucks having an articulating steer axle: point M shall be the projection on the tilt table of the intersection of the longitudinal centre-plane, A-A, of the truck with the axis of this axle.
- b) For trucks steered by a single wheel: point M shall be the centre point of the tread contact area between the steered wheel and the tilt table surface.
- c) For trucks steered by twin wheels: point M shall be the centre point of the tread contact area between the steered wheel closest to the tilt axis, X-Y, of the tilt table and the tilt-table surface.
- d) For trucks having wheels for steering not connected by a common axle, but that are arranged to articulate approximately about the longitudinal centre-plane of the truck: point M shall be the projection on the tilt table of the intersection of the longitudinal centre-plane of the truck, A-A, with the steer axle B-B connecting the vertical turning axis of the steer wheels.

As shown in Table 1, point N is defined as the centre point of the area of contact between the tilt table surface and the load wheel nearest to the tilt axis.

Table 1 — Verification of stability

Test criteria	Test 1	Test 2	Test 3	Test 4
Direction of test	Longitudinal	x		
	Lateral		x	x
Direction of load handling device	Load leading	x		
	Load trailing			
Mode of operation	Travelling	x		x
	Stacking/retrieving		x	
Load at load centre	With	x	x	
	Without			x
Lift height	Maximum	x	x	
	Travel			x
Position of mast	Vertical	x		
	Full rearward		x	x
Tilt-table angle for actual capacity	< 5 000 kg	4 %		(15 + 1,4 · γ) % ^a
	≥ 5 000 kg	3,5 %	6 %	(15 + 1,4 · γ) % ^b
Truck position on tilt table				
				

Table 1 (continued)

Test criteria	Test 1	Test 2	Test 3	Test 4
<p>Truck position on tilt table</p>		<p>As per 4.2.2</p>	<p>Points M and N</p>  <p>As per 4.2.3 a) or d)</p>	 <p>As per 4.2.3 b)</p>  <p>As per 4.2.3 c)</p>
<p>v is the travel speed of the unladen truck in km/h.</p>				
<p>a 50 % maximum.</p>				
<p>b For North America and Australia: 50 % maximum. For all other regions: 40 % maximum.</p>				
<p>c Parallel.</p>				

4.3 Datum point positions

Test 1 shall be conducted with the horizontal position of the load datum point, E, unchanged when elevated from its lowered position as shown in Figure 2.

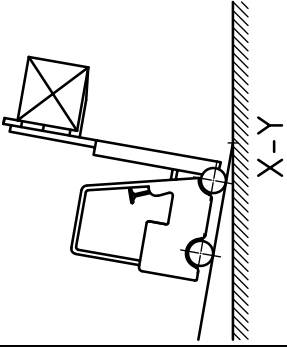
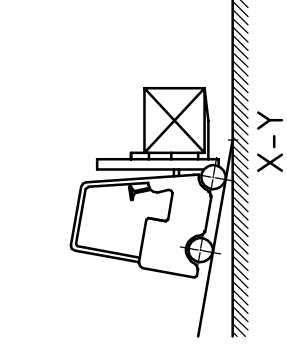
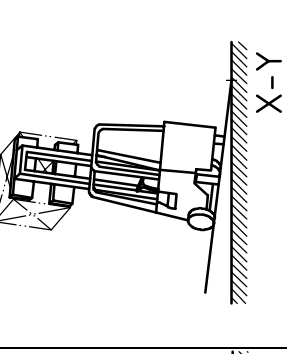
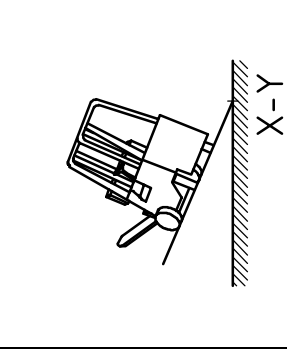
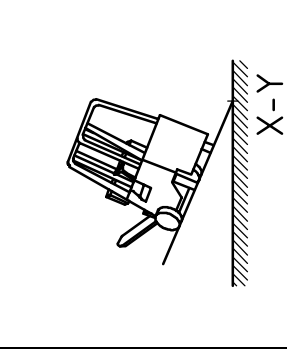
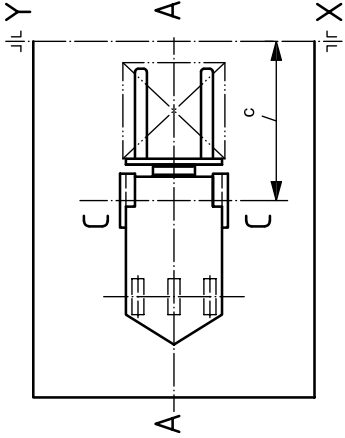
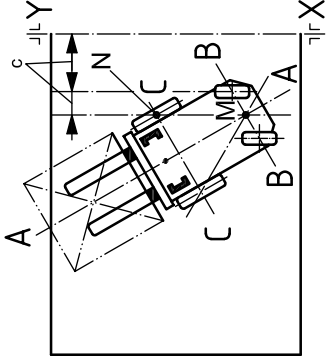
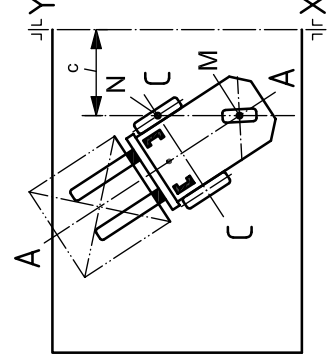
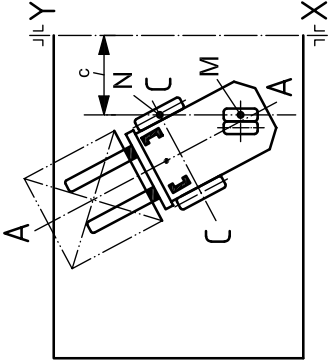
With the prescribed test load, set the mast vertical and then elevate to approximately 300 mm above the tilt table. With the shank of the front face of the fork arm set vertical, establish point E, as shown in Figure 2 a), on the fork arms or fork carrier having a fixed relationship to the centre of gravity of the test load. E shall be used to provide a reference datum point, F, on the tilt table. When the mast is elevated, a new point, F₁, on the tilt table may occur, as shown in Figure 2 b). This new point may be returned to the original location of F, as shown in Figure 2 c), by varying the tilt of the mast within the limits provided by the design of the truck.

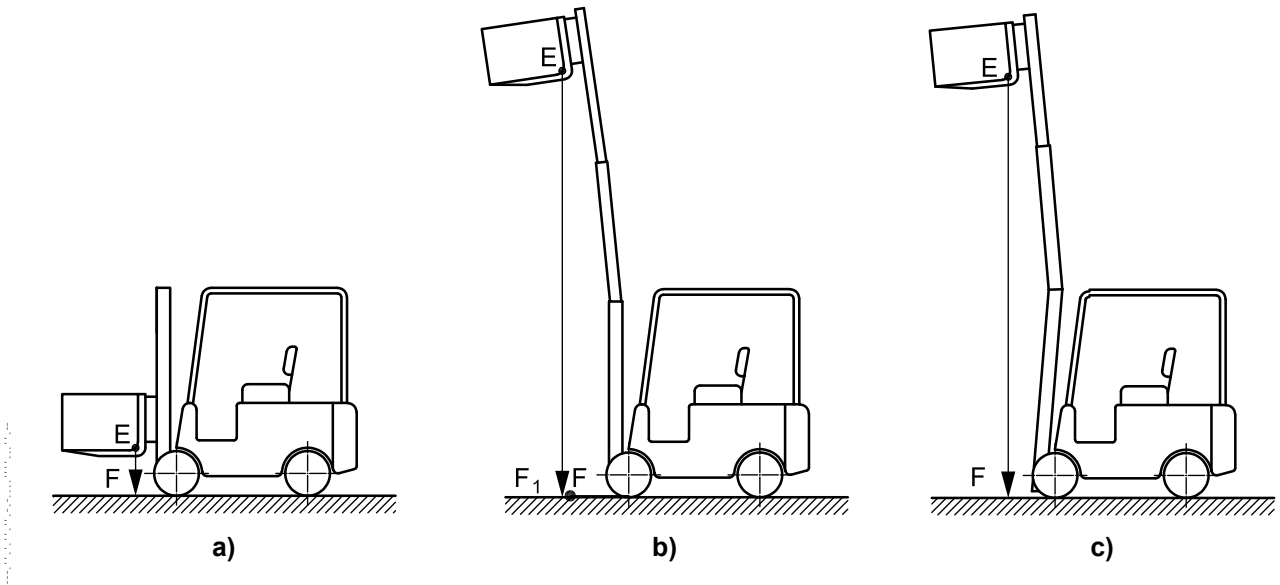

Figure 2 — Datum point positions

4.4 Lift height for tests simulating travel

For tests simulating travel (Tests 2 and 4), the upper face of the fork arms, measured at the heel of the fork arm, shall be positioned 300 mm above the tilt table for trucks with a rated capacity less than or equal to 10 t, and 500 mm for trucks with a rated capacity of greater than 10 t.

5 Verification of stability

5.1 General

The stability of a truck shall be verified in accordance with Table 1. Those trucks having a rated capacity greater than or equal to 5 000 kg are subject to the following regional requirements when their stability is verified using Test 4.

5.2 Regional requirements for trucks with rated capacity \geq 5 000 kg

5.2.1 North America and Australia

Maximum tilt-table angle required: 50 %.

5.2.2 All other regions

Maximum tilt-table angle required: 40 %.

© ISO 2008 – All rights reserved

.....

© ISO 2008. All rights reserved.

ICS 53.060

Price based on 6 pages