**Industrial trucks — Verification of
stability —**

Part 15:
**Counterbalanced trucks with
articulated steering**

Chariots de manutention — Vérification de la stabilité —

*Partie 15: Chariots avec dispositif de direction articulé travaillant
en porte-à-faux*



Reference number
ISO 22915-15:2013(E)

© ISO 2013



COPYRIGHT PROTECTED DOCUMENT

© ISO 2013

All rights reserved. Unless otherwise specified, no part of this publication may be reproduced or utilized otherwise in any form or by any means, electronic or mechanical, including photocopying, or posting on the internet or an intranet, without prior written permission. Permission can be requested from either ISO at the address below or ISO's member body in the country of the requester.

ISO copyright office
Case postale 56 • CH-1211 Geneva 20
Tel. + 41 22 749 01 11
Fax + 41 22 749 09 47
E-mail copyright@iso.org
Web www.iso.org

Published in Switzerland

Foreword

ISO (the International Organization for Standardization) is a worldwide federation of national standards bodies (ISO member bodies). The work of preparing International Standards is normally carried out through ISO technical committees. Each member body interested in a subject for which a technical committee has been established has the right to be represented on that committee. International organizations, governmental and non-governmental, in liaison with ISO, also take part in the work. ISO collaborates closely with the International Electrotechnical Commission (IEC) on all matters of electrotechnical standardization.

International Standards are drafted in accordance with the rules given in the ISO/IEC Directives, Part 2.

The main task of technical committees is to prepare International Standards. Draft International Standards adopted by the technical committees are circulated to the member bodies for voting. Publication as an International Standard requires approval by at least 75 % of the member bodies casting a vote.

Attention is drawn to the possibility that some of the elements of this document may be the subject of patent rights. ISO shall not be held responsible for identifying any or all such patent rights.

ISO 22915-15 was prepared by Technical Committee ISO/TC 110, *Industrial trucks*, Subcommittee SC 2, *Safety of powered industrial trucks*.

ISO 22915 consists of the following parts, under the general title *Industrial trucks — Verification of stability*:

- *Part 1: General*
- *Part 2: Counterbalanced trucks with mast*
- *Part 3: Reach and straddle trucks*
- *Part 4: Pallet stackers, double stackers and order-picking trucks with operator position elevating up to and including 1 200 mm lift height*
- *Part 5: Single-side-loading trucks*
- *Part 7: Bidirectional and multidirectional trucks*
- *Part 8: Additional stability test for trucks operating in the special condition of stacking with mast tilted forward and load elevated*
- *Part 10: Additional stability test for trucks operating in the special condition of stacking with load laterally displaced by powered devices*
- *Part 11: Industrial variable-reach trucks*
- *Part 12: Industrial variable-reach trucks handling freight containers of 6m (20ft) length and longer*
- *Part 13: Rough-terrain trucks with mast*
- *Part 12: Industrial variable-reach trucks handling freight containers of 6m (20ft) length and longer*
- *Part 14: Rough-terrain variable-reach trucks*
- *Part 15: Counterbalanced trucks with articulated steering*
- *Part 16: Pedestrian-propelled trucks*
- *Part 20: Additional stability test for trucks operating in the special condition of offset load, offset by utilization*
- *Part 21: Order-picking trucks with operator position elevating above 1 200 mm*
- *Part 22: Lateral- and front-stacking trucks with and without elevating operator position*

ISO 22915-15:2013(E)

The following parts are under preparation:

- *Part 9: Counterbalanced trucks with mast handling freight containers of 6 m (20 ft) length and longer*
Industrial and RTT lorry-mounted trucks are to form the subject of a future Part 23.

Industrial trucks — Verification of stability —

Part 15:

Counterbalanced trucks with articulated steering

1 Scope

This International Standard specifies the tests for verifying the stability of counterbalanced fork-lift trucks with articulating steering and with mast, equipped with fork arms or load-handling attachments.

It is not applicable to trucks with retractable devices such as a retractable mast or fork.

2 Normative references

The following documents, in whole or in part, are normatively referenced in this document and are indispensable for its application. For dated references, only the edition cited applies. For undated references, the latest edition of the referenced document (including any amendments) applies.

ISO 5053, *Powered industrial trucks — Terminology*

ISO 22915-1, *Industrial trucks — Verification of stability — Part 1: General*

3 Terms and definitions

For the purposes of this document, the terms and definitions given in ISO 5053 and ISO 22915-1 apply.

4 Test conditions

4.1 General

See ISO 22915-1.

4.2 Position of truck on tilt table

4.2.1 Load and steer axles

The load and steer axles are defined by [Figure 1](#).

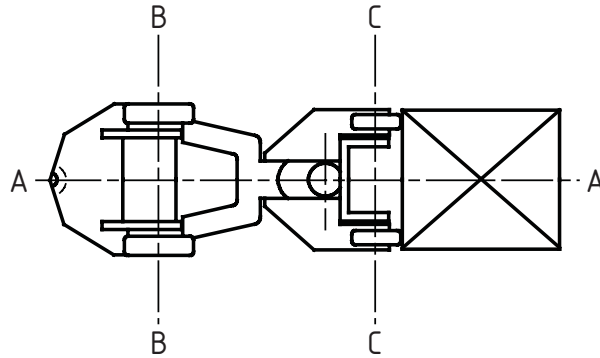

Key

- A-A longitudinal centre plane of truck
- B-B steer axle
- C-C load axle

Figure 1 — Load and steer axles

4.2.2 Test 1

The truck shall be positioned on the tilt table so that the load axle is parallel to the tilt axis, X-Y, of the tilt table, with the steering on full lock. See [Table 1](#).

4.2.3 Test 2

The truck shall be positioned on the tilt table so that the load axle and the steer axle are parallel to X-Y. See [Table 1](#).

4.2.4 Test 3, 4 and 5

The lateral stability tests according to [Table 1](#) shall be conducted on the side of the truck which is the least stable.

The truck shall be positioned on the tilt table in a turning position with line M-N parallel to X-Y. See [Table 1](#).

Point M is defined as the centre point of the area of contact between the tilt table surface and the rear wheel nearest to the tilt axis, X-Y, of the tilt table.

Point N is defined as the centre point of the area of contact between the tilt table surface and the load wheel nearest to the tilt axis, X-Y, of the tilt table.

4.3 Datum point positions

Test 1 shall be conducted with the horizontal position of the load datum point, E, unchanged when elevated from its lowered position, as shown in [Figure 2](#).

With the prescribed test load, set the mast vertical and then elevate to approximately 300 mm above the tilt table. With the shank of the front face of the fork arm set vertical, establish point E, as shown in [Figure 2 a](#)), on the fork arms or fork carrier having a fixed relationship to the centre of gravity of the test load. E shall be used to provide a reference datum point, F, on the tilt table. When the mast is elevated, a new point, F₁, on the tilt table may occur, as shown in [Figure 2 b](#)). This new point may be returned to the original location of F, as shown in [Figure 2 c](#)), by varying the tilt of the mast within the limits provided by the design of the truck.

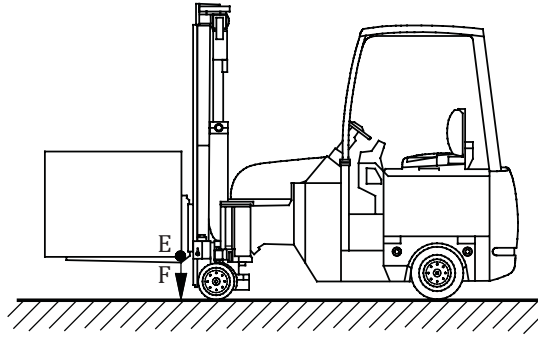

a)

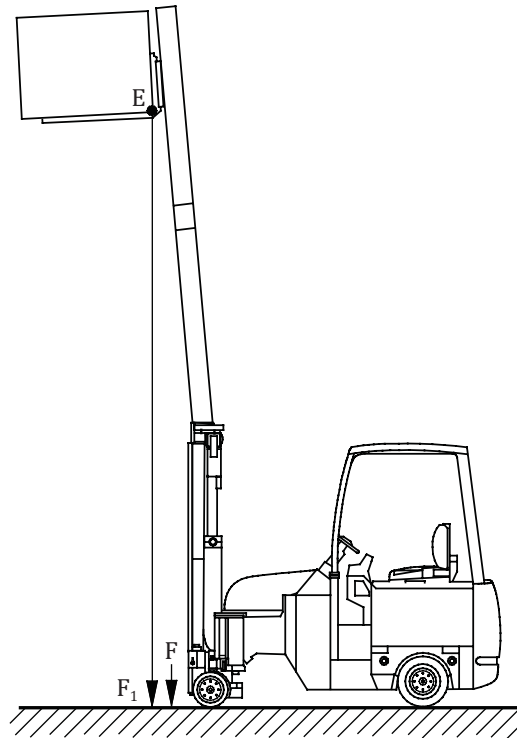

b)

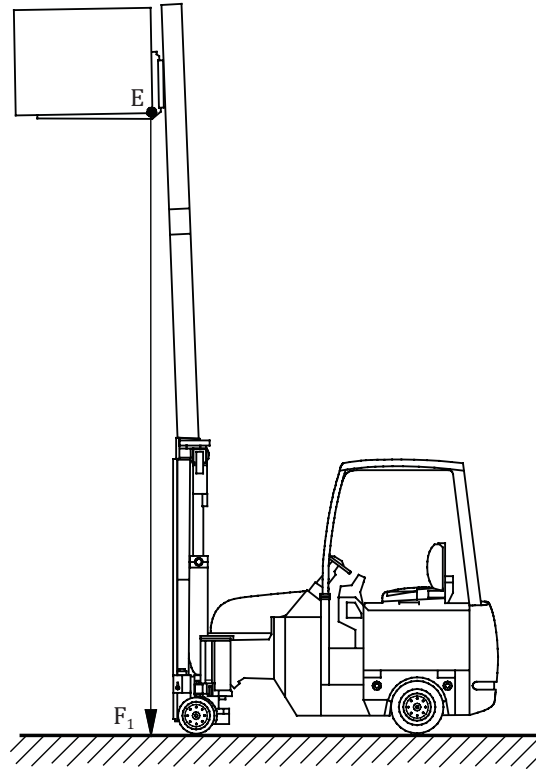

c)

Figure 2 — Datum point positions

4.4 Lift height for tests simulating travel

For tests simulating travel (Tests 2 and 5), the upper face of the fork arms, measured at the heel of the fork arm when fully tilted rearward, shall be positioned 300 mm above the tilt table for trucks with a rated capacity ≤ 10 t, and 500 mm for trucks with a rated capacity of > 10 t.

5 Verification of stability



The stability of a truck shall be verified in accordance with [Table 1](#).

Table 1 — Verification of stability

Test criteria	Test 1	Test 2	Test 3	Test 4	Test 5
Direction of test	Longitudinal	x			
	Lateral		x	x	x
Direction of load handling device	Load leading	x			
	Load trailing				
Mode of operation	Travelling		x		x
	Stacking/ retrieving	x		x	
Load at load centre	With	x	x		
	Without			x	x
Lift height	Maximum	x	x	x	
	Travel				x
Position of mast	Vertical	x			
	Full rearward		x	x	x
Tilt-table angle for actual capacity	< 5 000 kg	4 %	18 %	6 %	8 %
	≥ 5 000 kg	3,5 %			6 %

v is the maximum travel speed of the truck (unladen or laden with the actual load), in km/h.
a 50 % maximum.
b 40 % maximum.

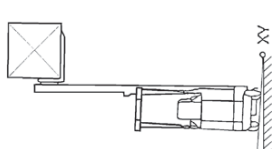
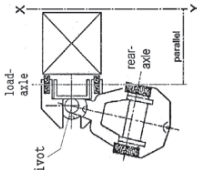
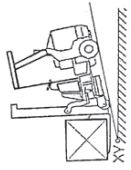
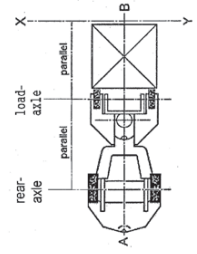
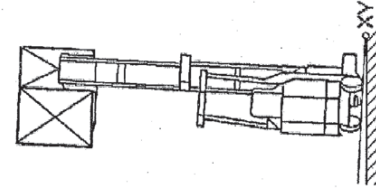
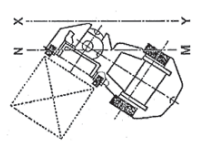
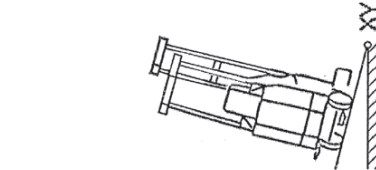
Table 1 — (continued)

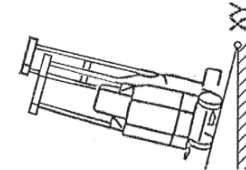
Test criteria	Test 1	Test 2	Test 3	Test 4	Test 5
<p>Truck position on tilt table</p>	 	 	 	 	
	<p>As per 4.2.2</p>	<p>As per 4.2.3</p>	<p>As per 4.2.4</p>	<p>As per 4.2.4</p>	

Vertical line of small characters or a barcode-like artifact on the left side of the page.

ICS 53.060

Price based on 6 pages