**Industrial trucks — Verification
of stability —**

**Part 14:
Rough-terrain variable-reach trucks**

Chariots de manutention — Vérification de la stabilité —

Partie 14: Chariots tout-terrain à portée variable



Reference number
ISO 22915-14:2010(E)

© ISO 2010

PDF disclaimer

This PDF file may contain embedded typefaces. In accordance with Adobe's licensing policy, this file may be printed or viewed but shall not be edited unless the typefaces which are embedded are licensed to and installed on the computer performing the editing. In downloading this file, parties accept therein the responsibility of not infringing Adobe's licensing policy. The ISO Central Secretariat accepts no liability in this area.

Adobe is a trademark of Adobe Systems Incorporated.

Details of the software products used to create this PDF file can be found in the General Info relative to the file; the PDF-creation parameters were optimized for printing. Every care has been taken to ensure that the file is suitable for use by ISO member bodies. In the unlikely event that a problem relating to it is found, please inform the Central Secretariat at the address given below.

.....



COPYRIGHT PROTECTED DOCUMENT

© ISO 2010

All rights reserved. Unless otherwise specified, no part of this publication may be reproduced or utilized in any form or by any means, electronic or mechanical, including photocopying and microfilm, without permission in writing from either ISO at the address below or ISO's member body in the country of the requester.

ISO copyright office
Case postale 56 • CH-1211 Geneva 20
Tel. + 41 22 749 01 11
Fax + 41 22 749 09 47
E-mail copyright@iso.org
Web www.iso.org

Published in Switzerland

Foreword

ISO (the International Organization for Standardization) is a worldwide federation of national standards bodies (ISO member bodies). The work of preparing International Standards is normally carried out through ISO technical committees. Each member body interested in a subject for which a technical committee has been established has the right to be represented on that committee. International organizations, governmental and non-governmental, in liaison with ISO, also take part in the work. ISO collaborates closely with the International Electrotechnical Commission (IEC) on all matters of electrotechnical standardization.

International Standards are drafted in accordance with the rules given in the ISO/IEC Directives, Part 2.

The main task of technical committees is to prepare International Standards. Draft International Standards adopted by the technical committees are circulated to the member bodies for voting. Publication as an International Standard requires approval by at least 75 % of the member bodies casting a vote.

Attention is drawn to the possibility that some of the elements of this document may be the subject of patent rights. ISO shall not be held responsible for identifying any or all such patent rights.

ISO 22915-14 was prepared by Technical Committee ISO/TC 110, *Industrial trucks*, Subcommittee SC 2, *Safety of powered industrial trucks*.

This first edition of ISO 22915-14, together with ISO 22915-13, cancels and replaces ISO 8379:1998, of which it constitutes a technical revision.

ISO 22915 consists of the following parts, under the general title *Industrial trucks — Verification of stability*:

- *Part 1: General*
- *Part 2: Counterbalanced trucks with mast*
- *Part 3: Reach and straddle trucks*
- *Part 4: Pallet stackers, double stackers and order-picking trucks with operator position elevating up to and including 1 200 mm lift height*
- *Part 7: Bidirectional and multidirectional trucks*
- *Part 8: Additional stability test for trucks operating in the special condition of stacking with mast tilted forward and load elevated*
- *Part 10: Additional stability test for trucks operating in the special condition of stacking with load laterally displaced by powered devices*
- *Part 11: Industrial variable-reach trucks*
- *Part 14: Rough-terrain variable-reach trucks*
- *Part 20: Additional stability test for trucks operating in the special condition of offset load, offset by utilization*
- *Part 21: Order-picking trucks with operator position elevating above 1 200 mm*

ISO 22915-14:2010(E)

The following part is under preparation:

— *Part 13: Rough-terrain trucks with mast*

Lateral- and front-stacking trucks with elevating operator position are to form the subject of a future Part 22.

Industrial trucks — Verification of stability —

Part 14: Rough-terrain variable-reach trucks

1 Scope

This part of ISO 22915 specifies tests for verifying the stability of rough-terrain variable-reach trucks, equipped with fork arms or with load carrying or non-load carrying attachments. It is not applicable to those trucks designed for handling freight containers or for lifting people or suspended loads.

2 Normative references

The following referenced documents are indispensable for the application of this document. For dated references, only the edition cited applies. For undated references, the latest edition of the referenced document (including any amendments) applies.

ISO 22915-1, *Industrial trucks — Verification of stability — Part 1: General*

3 Terms and definitions

For the purposes of this document, the terms and definitions given in ISO 22915-1 apply.

4 Test conditions

4.1 General

See ISO 22915-1.

4.2 Position of truck on the tilt table

4.2.1 Load and steer axles

The load axle and the steer axle are defined by Figure 1.

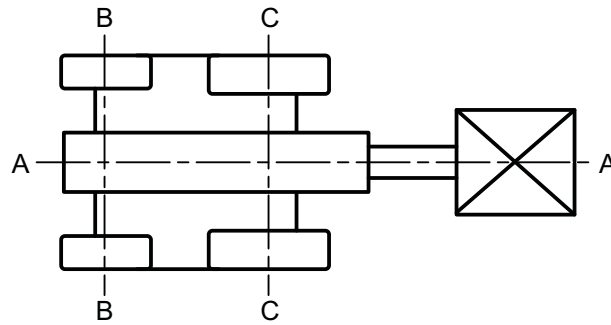

Key

- A-A longitudinal centre plane of truck
- B-B steer axle
- C-C load axle

NOTE The load axle may also be a steer axle on four-wheel steer trucks.

Figure 1 — Load and steer axes

4.2.2 Tests 1 and 2

The truck shall be positioned on the tilt table so that its load axle, C-C, is parallel to the tilt axis, X-Y, of the tilt table. See Table 1.

4.2.3 Tests 3, 4 and 5

The truck shall be positioned on the tilt table in a turning position with the line, M-N, parallel to the tilt axis, X-Y, of the tilt table. See Table 1.

For trucks with an articulating steer axle, the wheel on the steer axle nearest to the tilt axis, X-Y, shall be parallel to X-Y. See Table 1.

Point M is defined as follows:

- a) For trucks with an articulating steer axle: point M shall be the projection onto the tilt table of the intersection of the longitudinal centre plane, A-A, of the truck with the axis of the steer axle (see Table 1).
- b) For trucks with an articulating chassis: point M shall be the projection onto the tilt table of the intersection of the longitudinal centre plane, J-J, of the rear chassis module and the axis of the rear axle (see Table 1) when fully articulated.
- c) For trucks with axle locking: point M shall be the centre point of the area of contact between the tilt table and the rear wheel nearest to the tilt axis of the tilt table (see Table 1).

As shown in Table 1, point N is defined as the centre point of the area of contact between the tilt table surface and the load wheel (or stabilizer pad, if fitted) closest to the tilt axis, X-Y, of the tilt table.

4.3 Test load

Tests 1 and 3 shall be conducted with the test load in the least stable combination of lift and reach, with the fork arms parallel with the tilt table, and this shall remain unchanged during the tests.

The centre of gravity of the test load shall be positioned, according to ISO 22915-1, on the longitudinal centre plane of the truck, except where a lateral slope correction device is used, which is the case for Test 3.

See Table 1.

4.4 Lift height

For tests simulating travel, i.e. Tests 2 and 4, the upper face of the fork arms, measured at the heel of the fork arm when fully tilted rearward, shall be positioned

- 300 mm above the tilt table for trucks of 10 t rated capacity or less, and
- 500 mm for trucks of greater than 10 t rated capacity.

Test 5 shall be conducted at maximum and minimum boom extension, at maximum boom angle and with the fork arms in the horizontal position.

See Table 1.

4.5 Lateral test procedure

For trucks fitted with operator-selectable stabilizers and/or manual axle locking, Tests 1 and 3 shall be conducted both with stabilizers/axle locking engaged and disengaged.

For trucks fitted with operator-selectable stabilizers, or chassis levelling, Test 3 shall be performed with a maximum lateral slope correction of 7 % (4°). Lateral slope correction shall only be achieved by either operator-selectable stabilizers or lateral levelling.

For the other tests, the lateral slope correction shall not be used.

See Table 1.

5 Verification of stability

The stability of a truck shall be verified in accordance with Table 1.

6 Marking

The additional capacity, as determined by stability tests with stabilizers and or chassis levelling (see 4.5), shall be indicated on the load chart (see Annex A).

Table 1 — Verification of stability

Test criteria		Test 1	Test 2	Test 3	Test 4	Test 5
Direction of test	Longitudinal	x	x			
	Lateral			x	x	x
Direction of load-handling device	Load leading	x	x			
	Load trailing					
Mode of operation	Travelling		x		x	
	Stacking/retrieving	x		x		x
Load at load centre	With	x	x	x		
	Without				x	x
Lift/reach position	Max. and min. boom extension at max. boom angle					x
	Least stable combination	x		x		
	Travel		x		x	
Stabilizer device and/or axle locking device	With	x		x		
	Without	x	x	x	x	x
Lateral slope correction				x		
Position of fork arms	Horizontal	x		x		x
	Full rearward		x		x	
Tilt-table angle for actual capacity	≤ 10 000 kg	7 %	22 %	12 %	50 %	10 %
	> 10 000 kg	6 %		10 %	45 %	

Table 1 (continued)

Test criteria	Test 1	Test 2	Test 3	Test 4	Test 5
Truck position on tilt table	 	 	  <p style="text-align: center;">Two-wheel steer</p>	  <p style="text-align: center;">Four-wheel steer</p>  <p style="text-align: center;">Articulating chassis</p>	

Table 1 (continued)

Test criteria	Test 1	Test 2	Test 3	Test 4	Test 5
Truck position on tilt table			 <p style="text-align: center;">Stabilized</p>	 <p style="text-align: center;">Axles locked</p>	
a	Parallel.				

Annex A
(informative)

Example of load chart

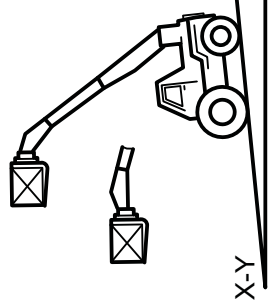
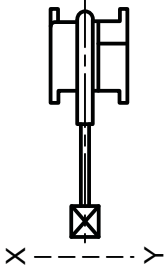
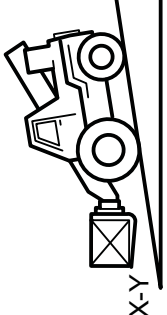
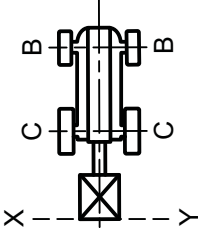
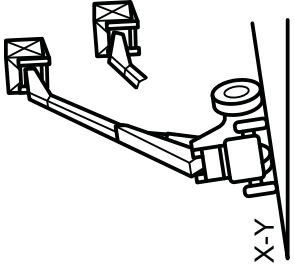
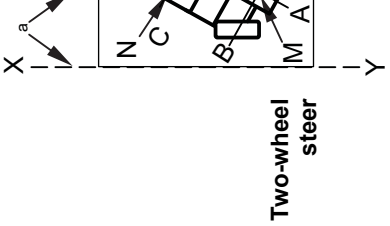
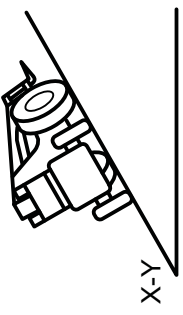
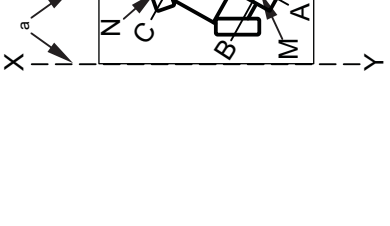
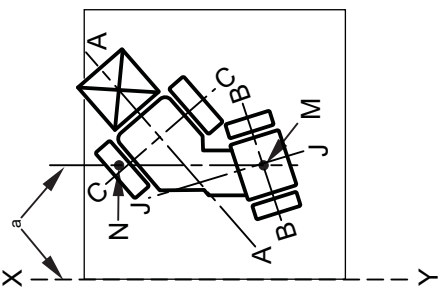
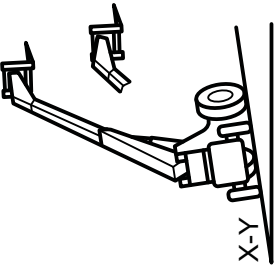
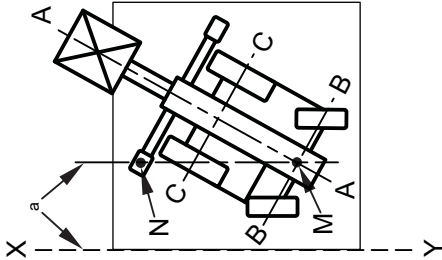
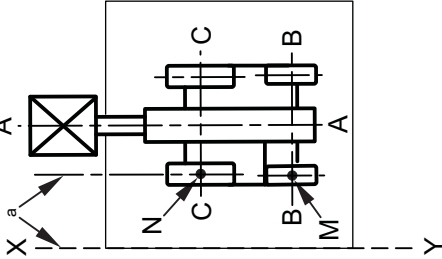
See Figure A.1.

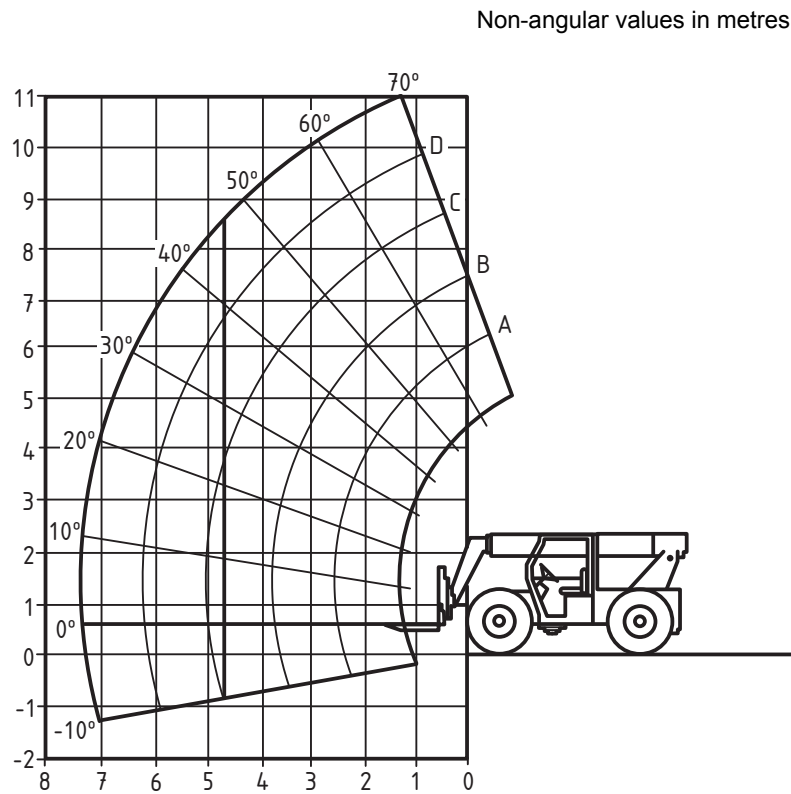

Figure A.1 — Load chart — Example

ICS 53.060

Price based on 7 pages