**Industrial trucks — Verification of
stability —**

Part 1:
General

*Chariots de manutention — Vérification de la stabilité —
Partie 1: Généralités*



PDF disclaimer

This PDF file may contain embedded typefaces. In accordance with Adobe's licensing policy, this file may be printed or viewed but shall not be edited unless the typefaces which are embedded are licensed to and installed on the computer performing the editing. In downloading this file, parties accept therein the responsibility of not infringing Adobe's licensing policy. The ISO Central Secretariat accepts no liability in this area.

Adobe is a trademark of Adobe Systems Incorporated.

Details of the software products used to create this PDF file can be found in the General Info relative to the file; the PDF-creation parameters were optimized for printing. Every care has been taken to ensure that the file is suitable for use by ISO member bodies. In the unlikely event that a problem relating to it is found, please inform the Central Secretariat at the address given below.



COPYRIGHT PROTECTED DOCUMENT

© ISO 2008

All rights reserved. Unless otherwise specified, no part of this publication may be reproduced or utilized in any form or by any means, electronic or mechanical, including photocopying and microfilm, without permission in writing from either ISO at the address below or ISO's member body in the country of the requester.

ISO copyright office
Case postale 56 • CH-1211 Geneva 20
Tel. + 41 22 749 01 11
Fax + 41 22 749 09 47
E-mail copyright@iso.org
Web www.iso.org

Published in Switzerland

Foreword

ISO (the International Organization for Standardization) is a worldwide federation of national standards bodies (ISO member bodies). The work of preparing International Standards is normally carried out through ISO technical committees. Each member body interested in a subject for which a technical committee has been established has the right to be represented on that committee. International organizations, governmental and non-governmental, in liaison with ISO, also take part in the work. ISO collaborates closely with the International Electrotechnical Commission (IEC) on all matters of electrotechnical standardization.

International Standards are drafted in accordance with the rules given in the ISO/IEC Directives, Part 2.

The main task of technical committees is to prepare International Standards. Draft International Standards adopted by the technical committees are circulated to the member bodies for voting. Publication as an International Standard requires approval by at least 75 % of the member bodies casting a vote.

Attention is drawn to the possibility that some of the elements of this document may be the subject of patent rights. ISO shall not be held responsible for identifying any or all such patent rights.

ISO 22915-1 was prepared by Technical Committee ISO/TC 110, *Industrial trucks*, Subcommittee SC 2, *Safety of powered industrial trucks*.

ISO 22915 consists of the following parts, under the general title *Industrial trucks — Verification of stability*:

- *Part 1: General*
- *Part 2: Counterbalanced trucks with mast*
- *Part 3: Reach and straddle trucks*
- *Part 4: Pallet stackers, double stackers and order-picking trucks with operator position elevating up to and including 1 200 mm lift height*
- *Part 7: Bidirectional and multidirectional trucks*
- *Part 8: Additional stability test for trucks operating in the special condition of stacking with mast tilted forward and load elevated*
- *Part 10: Additional stability test for trucks operating in the special condition of stacking with load laterally displaced by powered devices*
- *Part 20: Additional stability test for trucks operating in the special condition of offset load, offset by utilization*
- *Part 21: Order-picking trucks with operator position elevating above 1 200 mm*

The following parts are under preparation:

- *Part 5: Single side loading trucks*
- *Part 9: Counterbalanced trucks with mast handling freight containers of 6 m (20 ft) length and longer*
- *Part 11: Industrial variable reach trucks*
- *Part 12: Industrial variable reach trucks handling freight containers of 6 m (20 ft) length and longer*

- *Part 14: Rough-terrain variable reach trucks*
- *Part 15: Counterbalanced trucks with articulated steering*
- *Part 16: Pedestrian-propelled trucks*
- *Part 17: Burden and personnel carriers*

Introduction

An important step forward in work on the ISO 22915 series was the agreement to put in place a new structure. The stability tests are presented in the form of a basic part describing and defining stability tests in general, together with separate parts that each give specific stability test criteria and requirements for a different truck type.

From the very beginning, the task of the Working Group involved was to establish the new structure and revise existing standards to create a series of International Standards complying with the major legislative regulations in the world such as those in force in the EU, USA, Japan and Australia.

For several problem areas compromises were needed and will be needed in the future. In order to ensure that these International Standards are actively used in the ISO member countries worldwide, it will be necessary that they replace existing national standards.

Only in this way will there will be the guarantee that products in accordance with these International Standards can be shipped worldwide, freely and without any technical barriers to trade.

Industrial trucks — Verification of stability —

Part 1: General

1 Scope

ISO 22915 deals with the safety of industrial trucks, as defined in ISO 5053, relative to their stability and the verification of that stability. For the purposes of ISO 22915, industrial trucks are wheeled, self-propelled or pedestrian-propelled vehicles, excepting those running on rails. They are either operator-controlled or driverless and designed to carry, tow, push, lift, stack or tier in racks.

This part of ISO 22915 specifies basic test criteria and requirements to verify stability for industrial trucks, hereafter referred to as trucks.

It applies to the following truck types and special conditions:

- a) counterbalanced trucks with mast, as specified in ISO 22915-2;
- b) reach and straddle trucks, as specified in ISO 22915-3;
- c) pallet stackers, double stackers and order-picking trucks up to and including 1 200 mm lift height, as specified in ISO 22915-4;
- d) single side loading trucks¹⁾;
- e) bidirectional and multidirectional trucks, as specified in ISO 22915-7;
- f) additional stability test for trucks operating in special conditions of stacking with the mast tilted forward, as specified in ISO 22915-8;
- g) counterbalanced trucks with mast handling freight containers of 6 m (20 ft) length and longer¹⁾;
- h) additional stability test for trucks operating in special conditions with the load substantially laterally displaced by powered devices, as specified in ISO 22915-10;
- i) industrial variable reach trucks¹⁾;
- j) industrial variable reach trucks handling freight containers of 6 m (20 ft) length and longer¹⁾;
- k) rough-terrain variable reach trucks¹⁾;
- l) counterbalanced trucks with articulated steering¹⁾;
- m) pedestrian-propelled trucks¹⁾;
- n) burden and personnel carriers¹⁾;
- o) additional stability test for trucks operating in the special condition of offset load, offset determined by utilization, as specified in ISO 22915-20;
- p) order-picking trucks with operator position elevating above 1 200 mm, as specified in ISO 22915-21.

1) Intended to be covered by a future part of ISO 22915. See Foreword.

It also applies to trucks operating under the same conditions when equipped with load-handling attachments.

This part of ISO 22915 does not apply to:

- trucks handling suspended loads which may swing freely;
- low-lift trucks with lift height up to and including 500 mm.

2 Normative references

The following referenced documents are indispensable for the application of this document. For dated references, only the edition cited applies. For undated references, the latest edition of the referenced document (including any amendments) applies.

ISO 3411, *Earth-moving machinery — Physical dimensions of operators and minimum operator space envelope*

ISO 5053, *Powered industrial trucks — Terminology*

ISO 5353, *Earth-moving machinery, and tractors and machinery for agriculture and forestry — Seat index point*

3 Terms and definitions

For the purposes of this document, the following terms and definitions apply.

3.1

normal operating conditions

(trucks other than variable reach and rough-terrain trucks) operating conditions corresponding to

- a) stacking with fork arms reasonably horizontal on substantially firm, smooth, level, and prepared surfaces,
- b) operating with a load centre of gravity approximately on the longitudinal centre plane of the truck,
- c) travelling with the mast or fork arms tilted rearward, if possible, and the load in the lowered (travel) position on substantially firm, smooth, level, and prepared surface; for reach trucks, with the mast or forks fully retracted,
- d) travelling or manoeuvring with elevated load/operator (if the truck is specifically designed for this condition)

3.2

normal operating conditions

(variable reach and rough-terrain trucks) operating conditions corresponding to

- a) stacking with a combination of boom elevation/extension and the fork arms reasonably horizontal on substantially firm smooth, level and prepared surfaces,
- b) operating with the load centre of gravity approximately on the longitudinal centre plane of the truck,
- c) trucks with a mast, manoeuvring an elevated load with the mast neither tilted rearwards more than 10° nor the centre of gravity of the load displaced rearwards more than 600 mm,
- d) manoeuvring an elevated load with the fork arms tilted rearwards,
- e) rough-terrain trucks travelling with the mast or fork arms tilted rearwards and the load in the lowered (travelling) position on unimproved natural terrain and disturbed-terrain areas; where applicable, any reaching/telescopic mechanism is to be fully retracted

3.3**operating conditions other than normal**

operating conditions differing from those stated in 3.1 or 3.2, necessitating a truck that complies with either

- a) appropriate International Standards covering the different specific conditions (e.g. trucks operated with offset load by powered devices or by utilization, trucks with mast tilted forward and trucks handling freight containers), or
- b) stability requirements agreed upon by the interested parties in consultation with the manufacturer and being not less than required by the tests specified for normal operating conditions for that type of truck

3.4**tilt table**

rigid table tilted at least to one side to prove the lateral and longitudinal stability of a truck positioned on that table

See Figure 1.

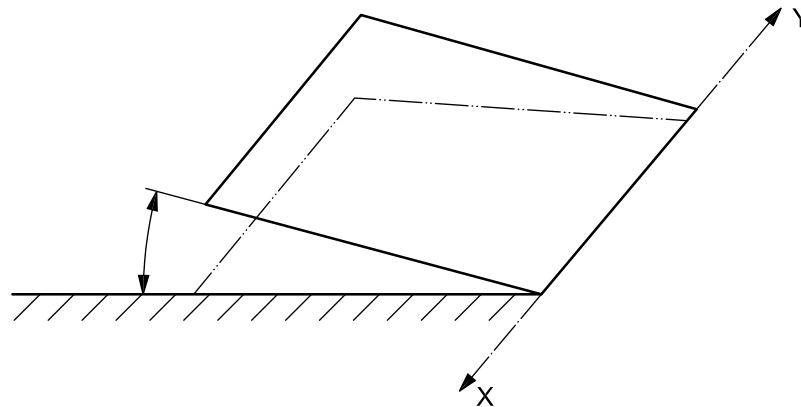
**Key**

X–Y indicates the tilt axis of the tilt table

Figure 1 — Tilt table

3.5**tilt axis**

axis about which the truck tips over, longitudinally or laterally, when a sufficient static or dynamic force is applied above the centre of gravity of the truck

See Figure 2.

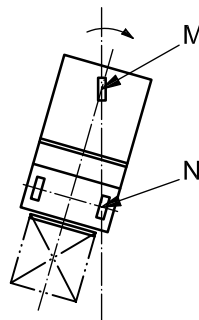
**Key**

M–N indicates the tilt axis of the truck

Figure 2 — Tilt axis

3.6

tip-over

loss of stability where the truck completely tips over

NOTE The point at which one or more wheels leave the tilt table, or the truck frame contacts the tilt table, is not tip-over.

4 Stability tests for trucks

4.1 Test procedure

Truck stability shall be verified by means of one of the procedures described below.

The truck is considered stable if it passes all tests without tip-over or meets the requirements by calculation.

When comparing calculated and test values, the test values are considered the true measure of stability.

4.2 Verification procedure

4.2.1 Operation of the tilt table and test criteria

The truck shall be placed on the tilt table under the conditions specified in the relevant part of ISO 22915. In each of these tests, the tilt table shall be tilted smoothly to the slope indicated.

The truck shall not tip over when the required tilt table slope is attained for all the specified tests.

It is permissible that one or more wheels leave the tilt table or parts of the truck frame contact the tilt table, except for trucks designed to handle freight containers 6 m (20 ft) length and above. If this occurs, the truck shall be allowed to seek its new stable position, or to tip over with no external restraint.

The means for preventing tip-over shall impose no appreciable restriction on the truck until the tip-over instant occurs.

4.2.2 Calculation

Compliance with the specified stability values may be determined by calculation.

Calculation shall be based on empirical data for similar trucks.

Such calculations shall take into account manufacturing variations and deflections of mast, tyres, etc.

4.2.3 Other methods

Other methods for verifying the stability that give the same result are allowed, e.g. fixed slope.

4.3 Test conditions

4.3.1 Condition of the truck

The tests shall be carried out on an operational truck.

The weight of the operator on sit-on and stand-on trucks shall be simulated by an object having a mass of 98 kg, according to ISO 3411, if the stability during a test is thereby decreased. For a truck designed for operation with a stand-on operator, the centre of gravity of the object shall be secured 1 000 mm above the floor of the operator's platform at the centre of the position normally occupied by the operator. For a truck designed for operation with a sit-on operator, the centre of gravity of the object shall be secured 150 mm above the seat index point (SIP), as determined in accordance with ISO 5353, with the seat at the mid-point of the adjustment, if provided.

Fuel tanks of internal combustion engine trucks shall be full if stability is thereby decreased. All other tanks shall be filled to their correct operating levels, as applicable.

Pneumatic tyres shall be inflated to their correct pressure as specified by the truck manufacturer. Where tyre ballast is incorporated in the truck design, the use of ballast shall be in accordance with the truck manufacturer's instructions.

4.3.2 Position of the truck on the tilt table

The truck shall be positioned on the tilt table under the conditions specified in the relevant part of ISO 22915. Lateral tests shall be conducted to the side that is least stable.

The indication of axles is the centreline of the respective axle. As shown in Figure 3, the longitudinal centre plane is the vertical longitudinal plane between the centreline of the steer axles and the centreline of the load axles.

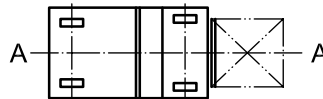

Key

A–A indicates the longitudinal centre plane of the truck

Figure 3 — Indication of longitudinal centre plane and axles

The initial location of the truck on the tilt table may be maintained by:

- applying parking or service brakes, which can be secured in the “on” position, or by wedging the wheels against the truck frame, ensuring however that articulation is not affected;
- using blocks, or chocks, having a maximum height not exceeding the value indicated in Table 1 — except for burden carriers — to maintain the initial position of the truck on the tilt table;
- increasing the coefficient of friction of the table surface, if necessary, by an appropriate friction-increasing material.

Table 1 — Maximum height of blocks or chocks

Tyre outside diameter <i>d</i> mm	Maximum height of blocks or chocks mm
$d \leq 250$	25
$d > 250$	$0,1d$
$d > 500$	50

4.3.3 Test load, lift height and standard load centre distance

The test load shall have a mass equivalent to the actual capacity, Q , that the truck can elevate to the corresponding height acting through the centre of gravity, G , nominally positioned at the standard load centre distance, D , (see Figure 4 and ISO 3691-1, ISO 3691-2, ISO 3691-3 and ISO 3691-5), as indicated on the information plate of the truck, both horizontally from the front face of the fork arm shank, and vertically from the upper face of the fork arm blade.

Other means may be used, providing these means gives the equivalent effect as a homogeneous mass.

When additional lift heights, loads, and load centre distances are to be indicated on the information plate, the truck shall meet the requirements established by the tests specified in this part of ISO 22915 for these additional capacities.

The centre of gravity, G , of the test load shall be located in the longitudinal centre plane A–A of the truck.

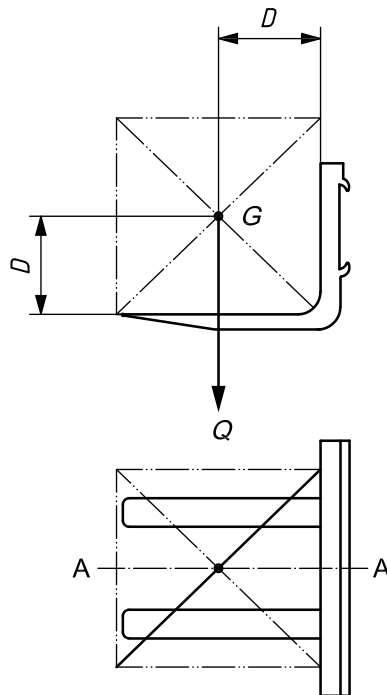

Key

- D standard load centre distance
- G load centre of gravity, positioned in the longitudinal centre plane (A–A) of the truck
- Q actual capacity

Figure 4 — Standard load centre distance

4.4 Safety precautions for testing

Precautions shall be taken to prevent the tip-over of the truck or displacement of the test load during the course of the test.

a) Complete tip-over of the truck shall be prevented by:

- wire ropes, straps or chains;
- overhead crane;
- other means.

b) Displacement of the test load shall be prevented by means such as:

- firmly securing the test load to the load carrier or equivalent structure;
- suspending the test load near the ground from an appropriate support placed on the fork arms so that the suspension point is at the point where the centre of gravity, G , of the test load would be if the test load were to be placed on the fork.

4.5 Stability verification for trucks with attachments

Trucks fitted with attachments other than fork arms shall be subject to the same stability tests. If the centre of gravity is substantially displaced, additional tests may be required (see other parts of ISO 22915). For verification of the vertical position of the mast, a reference point having a fixed relationship to the centre of gravity, G , of the test load shall be chosen (see Figure 4).

The test load shall be equivalent to the actual capacity at the specified load centre distance indicated for the attachment when used on the truck being tested.

On attachments that are not fitted with fork arms, the lift height specified for the tests shall be measured between the tilt table surface and the underside of the load, or the attachment, whichever is lower.

Bibliography

- [1] ISO 3691-1, *Industrial trucks — Safety requirements and verification — Part 1: Self-propelled industrial trucks other than driverless, variable-reach trucks and burden-carrier trucks*
- [2] ISO 3691-2, *Industrial trucks — Safety requirements and verification — Part 2: Self-propelled variable-reach trucks*
- [3] ISO 3691-3, *Industrial trucks — Safety requirements and verification — Part 3: Additional requirements for trucks with elevating operator position and trucks specifically designed to travel with elevated loads*
- [4] ISO 3691-5, *Industrial trucks — Safety requirements and verification — Part 5: Pedestrian-propelled trucks*

