**Road vehicles — Modular vehicle
communication interface (MVCI) —**

**Part 1:
Hardware design requirements**

*Véhicules routiers — Interface de communication modulaire du véhicule
(MVCI) —*

Partie 1: Exigences de conception du matériel



Reference number
ISO 22900-1:2008(E)

© ISO 2008

PDF disclaimer

This PDF file may contain embedded typefaces. In accordance with Adobe's licensing policy, this file may be printed or viewed but shall not be edited unless the typefaces which are embedded are licensed to and installed on the computer performing the editing. In downloading this file, parties accept therein the responsibility of not infringing Adobe's licensing policy. The ISO Central Secretariat accepts no liability in this area.

Adobe is a trademark of Adobe Systems Incorporated.

Details of the software products used to create this PDF file can be found in the General Info relative to the file; the PDF-creation parameters were optimized for printing. Every care has been taken to ensure that the file is suitable for use by ISO member bodies. In the unlikely event that a problem relating to it is found, please inform the Central Secretariat at the address given below.



COPYRIGHT PROTECTED DOCUMENT

© ISO 2008

All rights reserved. Unless otherwise specified, no part of this publication may be reproduced or utilized in any form or by any means, electronic or mechanical, including photocopying and microfilm, without permission in writing from either ISO at the address below or ISO's member body in the country of the requester.

ISO copyright office
Case postale 56 • CH-1211 Geneva 20
Tel. + 41 22 749 01 11
Fax + 41 22 749 09 47
E-mail copyright@iso.org
Web www.iso.org

Published in Switzerland

Contents

Page

Foreword.....	iv
Introduction	v
1 Scope	1
2 Normative references	1
3 Terms and definitions.....	2
4 Abbreviated terms	2
5 Specification release version information	3
5.1 Specification release version location	3
5.2 Specification release version	3
6 Use cases	3
6.1 OEM merger.....	3
6.2 Compatibility between VCIs from after-market tool suppliers.....	3
6.3 Future vehicle technology and data link(s).....	4
7 Modular VCI concept	4
7.1 Compliance levels.....	4
7.2 Tier 1 Modular VCI software compliance (SC)	4
7.3 Tier 2 Modular VCI electrical compliance (EC)	5
7.4 Tier 3 Modular VCI mechanical compliance (MC).....	6
7.5 Difference between software (SC) and electrical compliant (EC) MVCI Protocol Modules	7
8 Modular VCI compliance levels, hardware configurations and design requirements.....	8
8.1 General.....	8
8.2 Modular VCI “minimum compatibility” requirement matrix	8
8.3 Software compliance (SC) level design requirements.....	9
8.4 Electrical compliance (EC) level design requirements	12
8.5 Mechanical compliance (MC) level design requirements	16
8.6 Data Link Connector (DLC) cable and connector.....	21
9 Programmable power supply	26
10 General electrical requirements	27
11 General environmental durability requirements.....	27
Bibliography	28

Foreword

ISO (the International Organization for Standardization) is a worldwide federation of national standards bodies (ISO member bodies). The work of preparing International Standards is normally carried out through ISO technical committees. Each member body interested in a subject for which a technical committee has been established has the right to be represented on that committee. International organizations, governmental and non-governmental, in liaison with ISO, also take part in the work. ISO collaborates closely with the International Electrotechnical Commission (IEC) on all matters of electrotechnical standardization.

International Standards are drafted in accordance with the rules given in the ISO/IEC Directives, Part 2.

The main task of technical committees is to prepare International Standards. Draft International Standards adopted by the technical committees are circulated to the member bodies for voting. Publication as an International Standard requires approval by at least 75 % of the member bodies casting a vote.

Attention is drawn to the possibility that some of the elements of this document may be the subject of patent rights. ISO shall not be held responsible for identifying any or all such patent rights.

ISO 22900-1 was prepared by Technical Committee ISO/TC 22, *Road vehicles*, Subcommittee SC 3, *Electrical and electronic equipment*.

ISO 22900 consists of the following parts, under the general title *Road vehicles — Modular vehicle communication interface (MVCI)*:

- *Part 1: Hardware design requirements*
- *Part 2: Diagnostic protocol data unit application programming interface (D-PDU API)*
- *Part 3: Diagnostic server application programming interface (D-Server API)*

Introduction

The ISO 22900 series of standards is applicable to diagnose and program vehicle electronic control modules with off-board applications through the vehicle's communication interface.

This part of ISO 22900 has been established in order to define the requirements of cascading multiple communication interfaces supporting current, future, and legacy standardized and original equipment manufacturer (OEM) proprietary protocols implemented by different tool manufacturers. Today's situation in the automotive after-market requires different vehicle communication interfaces for different vehicle OEMs. Many vehicle communication interfaces are incompatible with regard to their interconnect ability because this was not a requirement when designed.

The objective of this part of ISO 22900 is to specify the hardware design requirements to support a "plug and play" type concept of different vehicle communication interfaces from different tool manufacturers. The hardware design requirements are applicable to different levels of compliance, and they will address the inter-vendor operability at the vehicle diagnostic connector end as well as the test equipment end, which executes the applications (Electronic Control Unit diagnostics, programming, etc.).

Implementation of the Modular Vehicle Communication Interface (MVCI) server concept supports overall cost reduction to the end user because a single diagnostic or programming application will support many vehicle communication interfaces supporting different protocols.

© ISO 2008. All rights reserved.

Road vehicles — Modular vehicle communication interface (MVCI) —

Part 1: Hardware design requirements

1 Scope

This part of ISO 22900 provides the framework to allow diagnostic and reprogramming software applications from all vehicle manufacturers the flexibility to work with multiple vehicle communication interfaces (VCI) from multiple tool suppliers. This system enables each vehicle manufacturer to support all vehicle communication interfaces to perform diagnostics and to control the programming sequence for electronic control units (ECUs) in their vehicles.

This part of ISO 22900 describes the applicable use cases to justify the benefits of ISO 22900. It also specifies the design requirements to be followed by diagnostic and programming vehicle communication interface designers. The design requirements are categorized into different levels of conformance classes to provide:

- “software compliance”, a set of requirements for existing VCIs, which are software but not hardware compliant;
- “electrical compliance”, defining all signals and electrical interfaces that allow a system integrator to connect more than one VCI Protocol Module to the vehicle diagnostic connector and the host system;
- “mechanical compliance”, defining standard connectors on the VCI Protocol Module to interface to the vehicle Data Link Connector (DLC) and the host system, as well as defining a cabling concept to support interfacing more than one VCI Protocol Module.

The technical requirements specified in this part of ISO 22900 have been influenced by the requirements of legal authority with regard to “vehicle OBD and programming”.

The Modular Vehicle Communication Interface hardware design requirements will provide appropriate development guidance for vehicle communication interface manufacturers to meet legal authority and automotive manufacturer demands with regard to inter-vendor operability.

2 Normative references

The following referenced documents are indispensable for the application of this document. For dated references, only the edition cited applies. For undated references, the latest edition of the referenced document (including any amendments) applies.

ISO 15031-3, *Road vehicles — Communication between vehicle and external equipment for emissions-related diagnostics — Part 3: Diagnostic connector and related electrical circuits, specification and use*

3 Terms and definitions

For the purposes of this document, the following terms and definitions apply.

3.1
Universal Serial Bus On-The-Go
USB OTG
supplement to the USB 2.0 specification that augments the capability of mobile devices and USB peripherals by adding host function for connection to USB peripherals

3.2
Ethernet
physical network media type

4 Abbreviated terms

API	Application Programming Interface
ASCII	American Standard for Character Information Interchange
DLC	Data Link Connector
DLL	Dynamic Link Library
D-PDU API	Diagnostic Protocol Data Unit Application Programming Interface
D-Server API	Diagnostic Server Application Programming Interface
EC	Electrical Compliance
ECU	Electronic Control Unit
MC	Mechanical Compliance
MVCI	Modular Vehicle Communication Interface
ODX	Open Diagnostic data eXchange
OEM	Original Equipment Manufacturer
PC	Personal Computer
PDA	Personal Digital Assistant
PDU	Protocol Data Unit
PEC	Protocol Expansion Connector
PEM	Protocol Expansion Module
PES	Protocol Expansion Slot
SC	Software Compliance
USB	Universal Serial Bus
USB OTG	Universal Serial Bus On-The-Go

5 Specification release version information

5.1 Specification release version location

Specification release version information is contained in each Modular VCI release document specification under the same title "Specification release version information". It is important to check for feature support between Modular VCI release specifications if the hardware and most recent API features shall be implemented. The D-PDU-API supports the reading of version information by the API function call `PDUGetVersion`.

Release version information is also contained in the following files:

- Root Description File (RDF);
- Module Description File (MDF);
- Cable Description File (CDF);
- D-PDU API Library File.

5.2 Specification release version

The specification release version of this part of ISO 22900 is: V2.2.0.

6 Use cases

6.1 OEM merger

In the past, several OEMs in the automotive industry have merged into one company.

All companies leverage existing (legacy) components and jointly develop new products, which are common across different vehicle types and badges. OEMs specify requirements and design electronic systems to be implemented in multiple vehicle platforms in order to avoid re-inventing a system for different vehicles. The majority of design, normal operation, and diagnostic data of an electronic system are re-used if installed in various vehicles. This may create situations where more than one OEM proprietary vehicle communication protocol needs to be supported by the off-board diagnostic and programming VCI.

At least two possible solutions are available to address this scenario:

- a) each dealership of the newly formed company shall have all OEM proprietary VCIs to diagnose/program the new vehicle design with carry over components/ECUs from legacy vehicles;
- b) each dealership of the newly formed company shall have a Modular VCI which meets the "mechanical compliance" requirement.

Solution b) is more attractive to an after-market dealership because of the flexibility to enhance the communication capability at any time.

6.2 Compatibility between VCIs from after-market tool suppliers

The after-market tool suppliers design VCIs according to protocol standards, which are referenced by legal authorities or implemented by OEMs to diagnose and program vehicle servers. Each VCI behaves differently and requires individual support and maintenance.

The Modular VCI concept provides different levels of compliance to provide compatibility between different Modular VCIs from different after-market tool suppliers.

6.3 Future vehicle technology and data link(s)

Vehicle technology is growing into faster and more complex data links. Legal authorities request industry to agree on a single solution data link, but do not limit the vehicle manufacturer to implement faster data busses, which might be connected to the vehicle diagnostic connector manufacturer proprietary pins.

Non Modular VCI compliant interfaces meet the communication requirements as specified for a particular model line, model year range, or a certain number of data links and protocols. In many cases, a VCI needs to be replaced if a new diagnostic data bus or protocol is implemented in the vehicle.

In order to adapt to new vehicle technology and data links, the Modular VCI concept specifies different compliance levels, which accommodate various levels of compatibility to provide data link and protocol enhancement capabilities.

7 Modular VCI concept

7.1 Compliance levels

This clause specifies three different compliance levels for the Modular VCI concept, as described in Table 1.

Table 1 — Modular VCI compliance levels

Tier	MVCI compliance levels	Description
1	Software compliance (SC)	Software compliance defines a set of requirements for existing VCIs, which are software but not hardware compliant (e.g. software solution).
2	Electrical compliance (EC)	Electrical compliance defines all signals and electrical interfaces that allow a system integrator to connect more than one VCI Protocol Module to the vehicle diagnostic connector and the host system. This compliance level includes Tier 1 Modular VCI software compliance.
3	Mechanical compliance (MC)	Mechanical compliance defines standard connectors on the VCI Protocol Module to interface with the vehicle DLC and the host system. In addition, it defines a cabling concept to support interfacing more than one VCI Protocol Module. This compliance level includes Tier 1 Modular VCI software compliance and Tier 2 Modular VCI electrical compliance.

7.2 Tier 1 Modular VCI software compliance (SC)

This compliance level neither requires compatibility between vehicle communication interfaces nor scan tool. Compliance is required in software and specified in ISO 22900-2 and ISO 22900-3.

Figure 1 shows software compliant VCI Protocol Module linked to the vehicle diagnostic connector utilizing the original cable [D] and diagnostic connector adapter [C]. The cable [D] is linked to the diagnostic connector adapter [C] via the connector [B]. The software compliant VCI Protocol Module uses the connection [J] to the host system. The host connection can be realized via cable or standard wireless technology.

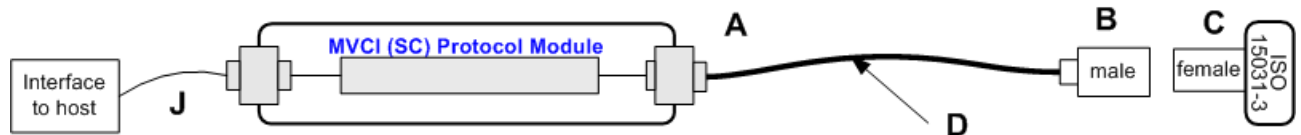

Key

- A MVCI Protocol Module standardized DLC connector
- B DLC connector to plug-in diagnostic connector adapter
- C Diagnostic connector adapter
- D Data Link Cable (DLC)
- J MVCI Protocol Module host connector

Figure 1 — Use case of Modular VCI software compliance (SC)

7.3 Tier 2 Modular VCI electrical compliance (EC)

This compliance level requires a high impedance state as the default state (power down, power on and no communication established) for each communication port (physical layer) supported in the electrical compliant VCI Protocol Module or scan tool hardware. This is required in order to combine more than one VCI Protocol module and/or scan tool hardware via a “Y-cable” design to the vehicle diagnostic connector. The communication ports shall only be enabled by software commands to the VCI Protocol Module or scan tools. It shall be the responsibility of the diagnostic, programming, and other applications to only enable electrically compatible protocols as well as valid combinations of communication protocols at the same diagnostic connector pin.

In addition, compliance is required in software and specified in ISO 22900-2 and ISO 22900-3.

The following describes a use case of more than one MVCI (EC) Protocol Module.

Figure 2 shows two electrical compliant MVCI (EC) Protocol Modules linked to the vehicle diagnostic connector utilizing the original cable [D] and the diagnostic connector adapter. A “Y” type cable [E] is used to connect both MVCI (EC) Protocol Modules to the DLC cable [D]. The tool supplier is free to choose the vehicle DLC connector types. It is recommended, but not required, to use the same DLC connector type as specified for “mechanical compliance”.

Figure 2 only shows one cable configuration of multiple configurations that are possible. It is the system integrator’s responsibility to ensure that the cabling system is compatible with the MVCI (EC) Protocol Modules that are being used.

Each MVCI (EC) Protocol Module uses a different connection [J] to the host system. In this example, the host connection of MVCI (EC) Protocol Module #1 is cable based and the MVCI (EC) Protocol Module #2 uses a standard wireless technology [cable of MVCI (EC) Protocol Module #2 is also shown because this is the standard interface to be implemented].

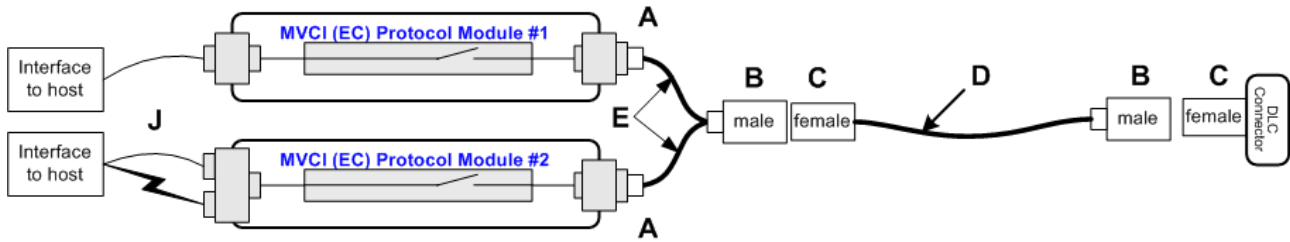

- Key**
- A MVCI Protocol Module standardized DLC connector
 - B DLC connector to plug-in diagnostic connector adapter
 - C Diagnostic connector adapter
 - D Data Link Cable (DLC)
 - E “Y” type cable is used to connect both MVCI (EC) Protocol Modules to the DLC cable
 - J MVCI Protocol Module host connector (either wired or wireless)

Figure 2 — Use case of two electrical compliant MVCI (EC) Protocol Modules

7.4 Tier 3 Modular VCI mechanical compliance (MC)

The mechanical compliance level requires a chassis with at least one vehicle protocol expansion slot to insert a vehicle Protocol Expansion Module (PEM). The purpose of this compliance level is to support protocol upgrade capability by a plug-in vehicle Protocol Expansion Module(s) into a Modular VCI chassis. The chassis provides a tool supplier specific vehicle Protocol Expansion Slot (PES) for a plug-in vehicle Protocol Expansion Module/card (PEM). In addition, the chassis may provide appropriate space for an integrated or plug-in server module/card.

The vehicle protocols integrated into a Modular VCI chassis are required to support a high impedance state for each vehicle protocol port (physical layer). This requirement enables the system to support multiple protocols on the same pin of the vehicle diagnostic connector. The vehicle communication ports shall be enabled by software commands. It shall be the responsibility of the diagnostic, programming, and other applications to only enable electrical compatible vehicle protocols as well as valid combinations of vehicle communication protocols at the same diagnostic connector pin.

Standard connectors are required on the chassis to interface with the vehicle Data Link Connector (DLC) and the host system. The vehicle Data Link Connector is specified in 8.6.2. The host system connector is specified in 8.5.5.5.

In addition, it defines a cabling concept to support interfacing more than one VCI Protocol Module.

Figure 3 shows one possible use case of Modular VCI mechanical compliance.

This Modular VCI chassis [A] has a server board [B], which also includes a base set of vehicle communication protocols. The front side of the chassis [A] provides two Protocol Expansion Slots [C] and [D]. A tool supplier specific vehicle Protocol Expansion Module/card (PEM) [E] can be inserted into the chassis [A].

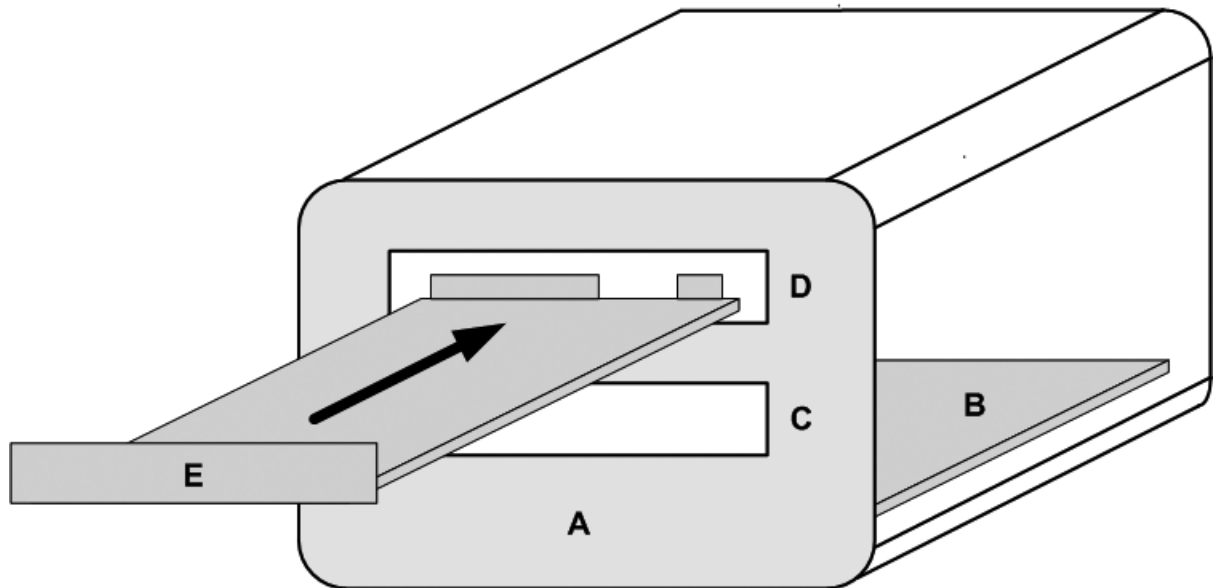
**Key**

- A Modular VCI chassis
- B MVCI server board
- C MVCI front side of the chassis
- D Protocol Expansion Slots (PES)
- E Protocol Expansion Module/card (PEM)

Figure 3 — Use case of Modular VCI mechanical compliance (MC)

7.5 Difference between software (SC) and electrical compliant (EC) MVCI Protocol Modules

The difference between software and electrical compliant MVCI Protocol Modules is the support of high impedance state as the default state (power down, power on, and no communication established) for each communication port (physical layer) supported in the vehicle communication interface hardware of the electrical compliant VCI Protocol Module. Electrical compliant MVCI Protocol Modules can be connected in parallel to the vehicle diagnostic connector. This is not possible with software compliant MVCI Protocol Modules.

In addition, the MVCI (EC) Protocol Module shall support, at a minimum, an Ethernet interface or a USB interface to the host computer system. The USB interface may be the USB 1.1 slave interface or USB OTG connection scheme. Additional host interfaces (e.g. wireless) can also be implemented.

Both compliance levels require the support of the D-PDU API in software. The host system interface [J] is tool supplier specific for both compliance levels. The DLC connection [A] is tool supplier specific for the software compliance level. The electrical compliance level requires an industry standard connector as specified in 8.6.2.

Figure 4 shows Software (SC) and electrical (EC) compliant MVCI Protocol Modules.



Key

- A MVCI (SC) Protocol Module tool supplier specific DLC connection
- J MVCI (SC) Protocol Module host connection
- A MVCI (EC) Protocol Module standardized DLC connection
- J MVCI (EC) Protocol Module host connection

Figure 4 — Software (SC) and electrical (EC) compliant MVCI Protocol Modules

8 Modular VCI compliance levels, hardware configurations and design requirements

8.1 General

The Modular VCI hardware requirements vary according to the three compliance levels described below.

- a) The “**software compliance level (SC)**” does not define any Modular VCI hardware requirements. Software compliance can be reached by supporting either the D-PDU API as specified in ISO 22900-2, or the D-Server API as specified in ISO 22900-3.
- b) The “**electrical compliance level (EC)**” specifies Modular VCI hardware requirements in the physical vehicle communication protocol layer interface. It defines all signals and electrical interfaces that allow a system integrator to connect more than one VCI Protocol Module. Electrical compliance can be reached by supporting either the D-PDU API as specified in ISO 22900-2, or the D-Server API as specified in ISO 22900-3, and in addition, the high impedance state switches for each communication port (physical layer).
- c) The “**mechanical compliance level (MC)**” specifies standard connectors on the VCI Protocol Module to interface with the vehicle DLC and the host system. In addition it defines a cabling concept to support interfacing more than one Modular VCI chassis. This compliance level includes Tier 1 Modular VCI software compliance and Tier 2 Modular VCI electrical compliance.

8.2 Modular VCI “minimum compatibility” requirement matrix

The “minimum compatibility” requirement matrix (see Table 2) provides an overview about available alternatives deriving from implementation and design use cases combined with a reference to applicable Modular VCI specifications.

Table 2 — Modular VCI “minimum compatibility” requirement matrix

Modular VCI supported alternatives and applicable specifications						
Applicable Modular VCI alternatives		Required clause of ISO 22900 Modular VCI specification part			Required clause of ISO 22901 ODX specification	
		Part 1: Hardware design	Part 2: D-PDU API	Part 3: D-Server API	Part 4: Enhanced Diagnostic Data in ODX format	Part 5: Emissions-related data (OBD) in ODX format ^a
#1	ODX support for OBD data with software compliant VCI Protocol Module	8.3	all clauses	—	—	all clauses
#2	ODX support for OBD data with electrical compliant VCI Protocol Module	8.4	all clauses	—	—	all clauses
#3	ODX support for OBD data with mechanical compliant VCI Protocol Module	8.5	all clauses	—	—	all clauses
#4	ODX support for Enhanced Diagnostic Data with software compliant VCI Protocol Module	8.3	all clauses	—	all clauses	—
#5	ODX support for Enhanced Diagnostic Data with electrical compliant VCI Protocol Module	8.4	all clauses	—	all clauses	—
#6	ODX support for Enhanced Diagnostic Data with VCI mechanical compliant Protocol Module	8.5	all clauses	—	all clauses	—
#7	Modular VCI software compliance	8.3	all clauses	—	—	—
#8	Modular VCI electrical compliance	8.4	all clauses	—	—	—
#9	Modular VCI mechanical compliance	8.5	all clauses	—	—	—
#10	Modular VCI D-Server API support and software compliance	8.3	all clauses	all clauses	—	—
#11	Modular VCI D-Server API support and electrical compliance	8.4	all clauses	all clauses	—	—
#12	Modular VCI D-Server API support and mechanical compliance	8.5	all clauses	all clauses	—	—

^a Emissions-related diagnostic data in ODX is the subject of a future part of ISO 22901, which is currently under development.

8.3 Software compliance (SC) level design requirements

8.3.1 Applicable Modular VCI hardware configurations according to software compliance (SC)

This subclause specifies the minimum requirements to be fulfilled if the Modular VCI shall meet the “software compliance (SC)” level.

Figure 5 and Figure 6 explain the various possible Modular VCI configurations in order to reach software compliance level. Two alternatives are possible for software compliance.

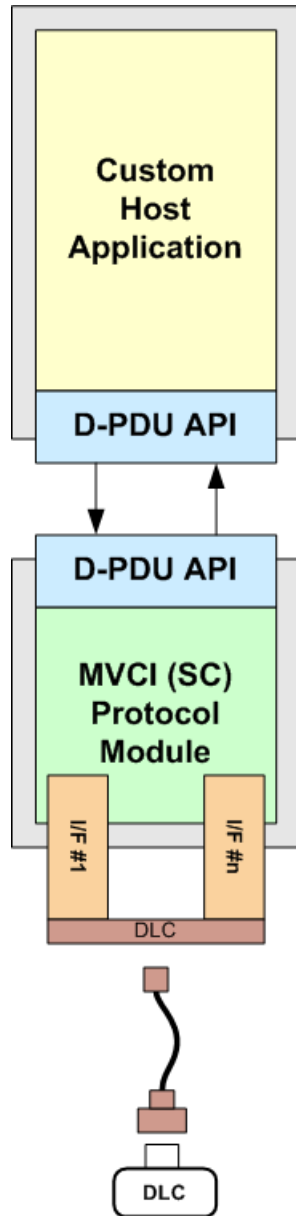

NOTE This figure does not show all possible system partitioning.

Figure 5 — Software compliant (SC) system hardware alternative #1

The application requirements are not covered by this part of ISO 22900. The host custom application supports the D-PDU API to the MVCI (SC) Protocol Module.

The software compliant MVCI Protocol Module only supports the D-PDU API. It is the tool supplier's responsibility which vehicle communication protocols are supported.

The Modular VCI tool supplier specific DLC (Data Link Connector) cable is designed to connect one VCI Protocol Module to the vehicle diagnostic connector.

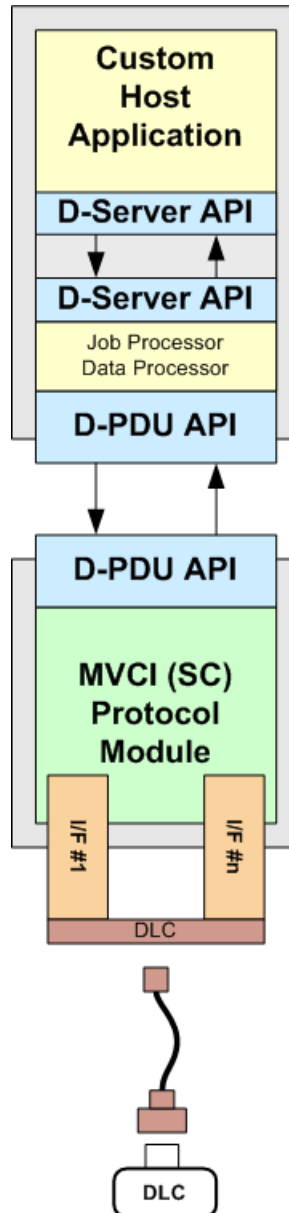

NOTE This figure does not show all possible system partitioning.

Figure 6 — Software compliant (SC) system hardware alternative #2

The application requirements are not covered by this part of ISO 22900. The software compliant Modular VCI supports the D-Server API (TCP/IP based protocol).

The software compliant MVCI Protocol Module only supports the D-PDU API. It is the tool supplier's responsibility which vehicle communication protocols are supported.

The Modular VCI tool supplier specific DLC (Data Link Connector) cable is designed to connect one VCI Protocol Module to the vehicle diagnostic connector.

8.3.2 MVCI (SC) Protocol Module hardware requirements

8.3.2.1 MVCI (SC) Protocol Module ground isolation

No hardware requirements are specified in this part of ISO 22900 which are applicable to the design of a software compliant (SC) MVCI Protocol Module.

The MVCI (SC) Protocol Module is not required to support ground isolation between the DLC connector and the host interface connector end.

8.3.2.2 MVCI (SC) Protocol Module power supply requirements

It is the tool supplier's responsibility, which voltage range, current and tolerances are supported by the power supply in the design of the MVCI (SC) Protocol Module. These requirements depend on the vehicle protocols and diagnostic connector specifications to be supported. The amount of current drawn from the vehicle shall be consistent with the diagnostic connector specification.

8.3.3 MVCI (SC) Protocol Module usage requirements

The MVCI (SC) Protocol Module is required to operate in a "single VCI" environment when connected between a vehicle and host system.

8.3.4 MVCI (SC) Protocol Module interface requirements

8.3.4.1 MVCI (SC) Protocol Module vehicle communication interface requirements

It is the tool supplier's responsibility which vehicle communication protocols are supported in the design of the MVCI (SC) Protocol Module.

8.3.4.2 MVCI (SC) Protocol Module host communication interface requirements

It is the tool supplier's responsibility which host interface protocol is supported in the design of the MVCI (SC) Protocol Module.

8.3.5 MVCI (SC) Protocol Module API support

Software compliance requires applicability to Part 2 of the Modular VCI document that specifies the "D-PDU (Diagnostic Protocol Data Unit) API" to be supported by the host interface. This API provides a set of function calls to allow protocol independent message data content transfer between the host system software and the MVCI (SC) Protocol Module interface.

8.3.6 MVCI (SC) Protocol Module design

There are no design requirements specified in this part of ISO 22900 for the development of a diagnostic and/or programming interface or scan tool. Any type of housing, material, dimensions and connector types can be chosen for the design of the software compliant MVCI (SC) Protocol Module. For example, an optional host interface (e.g. wireless technology by a plug-in PCMCIA card) can be supported instead of an industry standard (i.e. USB host interface).

8.4 Electrical compliance (EC) level design requirements

8.4.1 Applicable Modular VCI hardware configurations according to electrical compliance (EC)

This subclause specifies the minimum requirements to be fulfilled if the Modular VCI shall meet the "electrical compliance (EC)" level.

Figure 7 and Figure 8 explain the various possible Modular VCI configurations in order to reach electrical compliance. Two alternatives are possible for electrical compliance level.

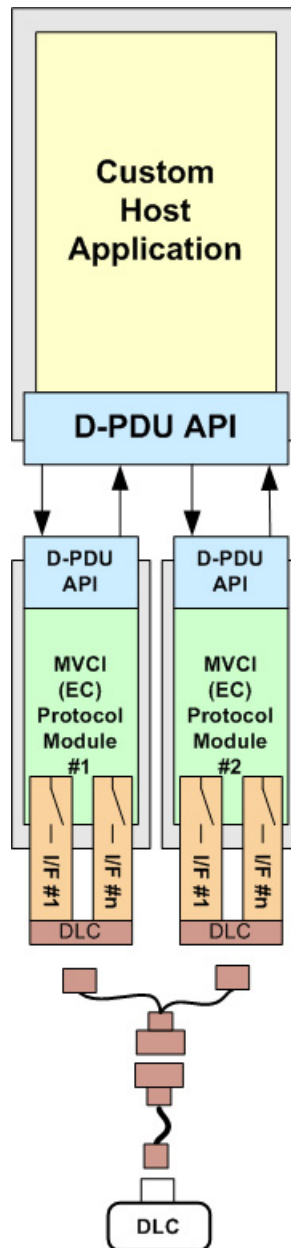

NOTE This figure does not show all possible system partitioning.

Figure 7 — Electrical compliance (EC) system hardware alternative #1

The application requirements are not covered by this part of ISO 22900. The host custom application supports the D-PDU API and uses at a minimum the USB or Ethernet as a physical interface. The physical interface to the MVCI Protocol Module is not defined in this part of ISO 22900 (e.g. WIN32 PDU DLL, shared objects, etc.).

The electrical compliant MVCI Protocol Module(s) supports the D-PDU API and uses at a minimum the USB 1.1 slave (or USB OTG) or Ethernet as a physical interface. It is the tool supplier's responsibility which vehicle communication protocols are supported.

The Modular VCI tool supplier specific DLC (Data Link Connector) cable is designed either with a "Y" or "splitter" type cable to connect more than one VCI (EC) Protocol Module to the vehicle diagnostic connector.

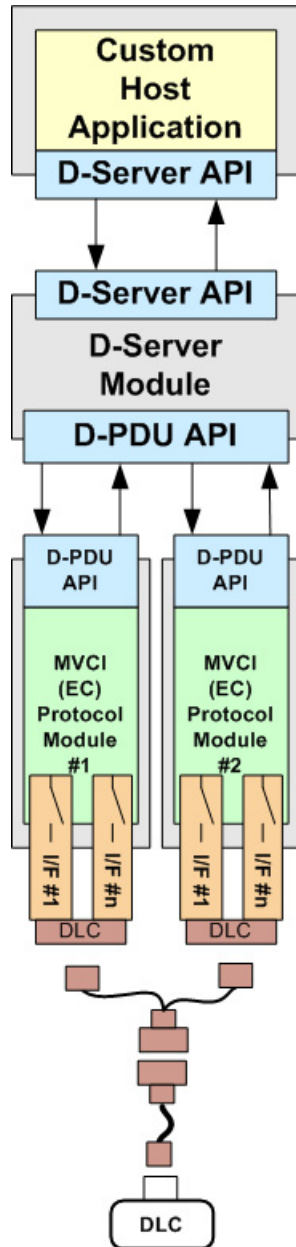

NOTE This figure does not show all possible system partitioning.

Figure 8 — Electrical compliance (EC) system hardware alternative #2

The application requirements are not covered by this part of ISO 22900. The Modular VCI shown in Figure 8 supports the D-Server API (TCP/IP based protocol).

The Modular VCI Server Module supports the D-Server API and D-PDU API and uses at a minimum the USB or Ethernet as a physical interface.

The Modular VCI tool supplier specific DLC (Data Link Connector) cable is designed to either support a “Y” or “splitter” type cable to connect more than one VCI (EC) Protocol Module to the vehicle diagnostic connector.

8.4.2 MVCI (EC) Protocol Module hardware requirements

8.4.2.1 MVCI (EC) Protocol Module ground isolation

No hardware requirements are specified in this part of ISO 22900 which are applicable to the design of an “electrical compliant (EC)” MVCI Protocol Module except those specified in this subclause.

The MVCI (EC) Protocol Module is required to support ground isolation between the DLC connector and the host interface connector end.

For an electrically compliant MVCI Protocol Module, ground isolation shall be maintained between the vehicle’s chassis ground and signal ground (see 8.6.3.2). For a system consisting of multiple MVCI (EC) Protocol Modules, it is the system integrator’s responsibility to ensure that this ground isolation is maintained.

8.4.2.2 MVCI (EC) Protocol Module power supply requirements

It is the tool supplier’s responsibility, which voltage range, current and tolerances are supported by the power supply in the design of the MVCI (EC) Protocol Module. These requirements depend on the vehicle protocols and diagnostic connector specifications to be supported.

The requirements below apply.

- The amount of current drawn from the vehicle’s diagnostic connector shall be limited to 1 A at 12 V d.c. (0,5 A at 24 V d.c.) per MVCI (EC) Protocol Module. There shall be no more than three MVCI (EC) Protocol Modules connected to the vehicle’s diagnostic connector at the same time. A “splitter” type DLC cable shall not have more than three connections to MVCI (EC) Protocol Modules.
- It is the responsibility of the system integrator to ensure compatibility of the power supplies of the MVCI (EC) Protocol Modules and the vehicle DLC power supply. If one or more MVCI (EC) Protocol Modules use signal ground for the power return, it is the system integrator’s responsibility to ensure that the current in the signal ground path complies with the specification for the vehicle’s diagnostic connector (e.g. no more than 1,5 A for the ISO 15031-3 connector).

8.4.2.3 MVCI (EC) Protocol Module vehicle communication port high impedance requirement

The MVCI (EC) Protocol Module shall include high impedance state switches for each DLC serial communication data line except power and ground supply lines. This requirement supports the concept of vehicle communication protocol software selection as needed on a specific pin at the vehicle’s diagnostic connector. The default state of the high impedance state switches at power down, power on and after a reset shall always be open (no electrical connection). The control of the high impedance state switches shall only be possible through the API function calls as specified in Part 2 and Part 3 of the Modular VCI specifications.

NOTE When in the high impedance state, the switch may be subject to voltage spikes and other electrical disturbances, coming from the unused pins, exceeding those specified for the supported protocols. It is the tool supplier’s responsibility to ensure proper electrical protection of the switch.

8.4.3 MVCI (EC) Protocol Module usage requirements

The MVCI (EC) Protocol Module shall operate in a “single VCI” as well as in a “multiple VCI (maximum of three (3))” environment when connected between a vehicle and host system.

If more than one MVCI (EC) Protocol Module is required to be connected to the vehicle’s diagnostic connector, a “Y” type or “splitter” type DLC cable (see 8.6.6) is required to route the supported vehicle communication protocols of more than one MVCI (EC) Protocol Module to the vehicle’s diagnostic connector.

8.4.4 MVCI (EC) Protocol Module interface requirements

8.4.4.1 MVCI (EC) Protocol Module vehicle communication interface requirements

It is the tool supplier's responsibility which vehicle communication protocols are supported in the design of the MVCI (EC) Protocol Module.

8.4.4.2 MVCI (EC) Protocol Module host communication interface requirements

An MVCI (EC) Protocol Module can utilize either USB or Ethernet for host communication. The host communication interface provides three alternatives to be implemented, as described below.

- a) An Ethernet interface: in order to be electrical compliant, an MVCI (EC) Protocol Module shall be able to communicate at least via 10BaseT with the host system in case of a wired link. An MVCI (EC) Protocol Module can also use a WLAN interface to be electrical compliant.
- b) The USB 1.1 slave interface requires a USB master as a host system in order to perform vehicle communication. Personal Computers usually have only USB master (host) ports. PDAs and mobile phones are usually equipped with USB slave ports. To make a Modular MVCI (EC) Protocol Module "strictly" a USB slave device means that it will only be able to connect to a device capable of being a USB master (host), precluding the direct use of the vast majority of PDA with USB slave ports as potential operator interfaces. To implement the full functionality of a USB master (host) port on an MVCI (EC) Protocol Module would be cost prohibitive, most certainly precluding the concept of integrating both types of ports on an MVCI (EC) Protocol Module to address this issue.
- c) The USB OTG interface provides dual-role (master/slave) functionality and supports master and slave host systems in order to perform vehicle communication. The USB OTG standard allows for the implementation of a reduced functionality master (host) port, allowing for a cost effective implementation on an 8-bit or a 16-bit microcontroller. A USB OTG equipped MVCI (EC) Protocol Module would be able to connect to either a USB master (host) or a slave with a single USB port, a physical implementation that only USB OTG provides for. In addition, allowing two OTG ports on an MVCI (EC) Protocol Module would provide for "integrated HUB" functionality, allowing MVCI (EC) Protocol Modules to be electrically cascaded in a daisy-chain arrangement.

8.4.5 MVCI (EC) Protocol Module D-PDU API support

Electrical compliance requires applicability to Part 2 of the Modular VCI, which specifies the "D-PDU (Diagnostic Protocol Data Unit) API" to be supported by the host interface protocol. This API provides a set of function calls to allow protocol independent message data content transfer between the host system software and the MVCI (EC) Protocol Module interface.

8.4.6 MVCI (EC) Protocol Module vehicle communication interface connector

There are no design requirements specified in this part of ISO 22900 for the development of the internal implementation of the diagnostic protocol interfaces and the module housing.

The connector type is tool supplier specific.

The electrical compliance level does not define a certain connector type. This is tool supplier specific. It is important that all communication related pins have a high impedance switch. This is required in cases where more than one MVCI (EC) Protocol Module will be connected in parallel.

8.5 Mechanical compliance (MC) level design requirements

8.5.1 Applicable Modular VCI hardware configurations according to mechanical compliance (MC)

This subclause specifies the "minimum" design requirements to be fulfilled if the Modular VCI shall meet the "mechanical compliance (MC)" level.

Figure 9 and Figure 10 explain the various possible Modular VCI configurations in order to reach mechanical compliance. Two alternatives are possible for mechanical compliance level.

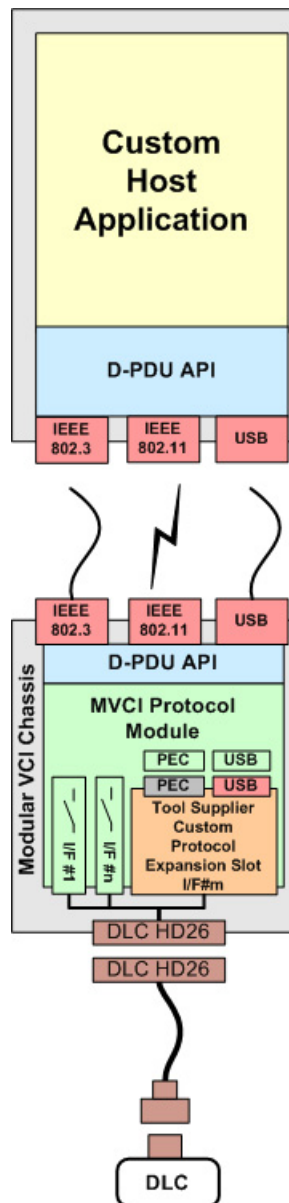

NOTE This figure does not show all possible system partitioning.

Figure 9 — Mechanical compliant (MC) system hardware alternative #1

The application requirements are not covered by this part of ISO 22900. The host custom application supports the D-PDU API via USB or Ethernet interface, e.g. WIN32 PDU DLL, shared objects, etc.

The VCI Protocol Module built in the MVCI chassis serves the D-PDU API and uses at a minimum the USB 1.1 slave (or USB OTG) or Ethernet as a physical interface. The DLC connection provides a power supply from the vehicle. All MVCI vehicle protocol module enhancements are optional and shall be made available through the Protocol Expansion Connector (PEC) or through a USB port. Possible enhancement options are as described below.

- a) Only the Physical Layer protocol module/card is connected via the PEC. The entire vehicle protocol module/card is connected via an optional USB 1.1 slave. It is the tool supplier's responsibility which vehicle communication protocols are supported.
- b) The Modular VCI tool supplier specific DLC (Data Link Connector) cable is designed to utilize an HD26 connector (see 8.6.2).

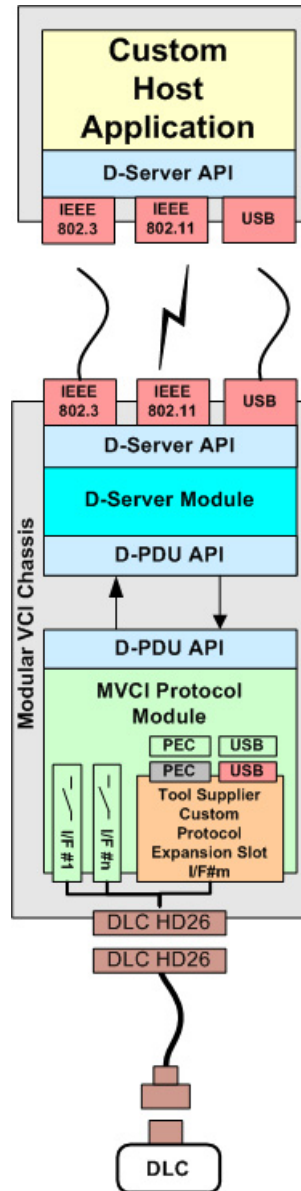

NOTE This figure does not show all possible system partitioning.

Figure 10 — Mechanical compliant (MC) system hardware alternative #2

The application requirements are not covered by this part of ISO 22900.

The mechanical compliant Modular VCI supports the D-Server API (TCP/IP based protocol) via industry standard interface(s) (e.g. Ethernet, Wireless, USB, other).

The Modular VCI Server supports the D-Server API and the D-PDU API. The Server Module and MVCI Protocol Module are included in the MVCI chassis. All MVCI Protocol Module enhancements are optional and

shall be made available through the Protocol Expansion Connector (PEC) or optionally through a USB 1.1 slave port.

Possible enhancement options are:

- only the Physical Layer protocol module/card is connected via the PEC;
- the entire vehicle protocol module/card is connected via the optional USB 1.1 slave.

The DLC connection provides a power supply from the vehicle. It is the tool supplier's responsibility which vehicle communication protocols are supported.

The Modular VCI tool supplier specific DLC (Data Link Connector) cable design utilizes an HD26 connector (see 8.6.2).

8.5.2 MVCI (MC) Protocol Module hardware requirements

8.5.2.1 Modular VCI (MC) vehicle protocol support

It is the tool supplier's responsibility which vehicle communication protocols are supported.

There are no design requirements specified in this part of ISO 22900 for the development of the internal implementation of the vehicle protocol interfaces.

8.5.2.2 Modular VCI (MC) vehicle protocol expansion capability

A Modular VCI (MC) chassis shall support at least one vehicle Protocol Expansion Slot (PES). The expansion slot dimensions, expansion slot keying, electrical specification and the vehicle Protocol Expansion Module/Card (PEM) design shall be the tool supplier's responsibility.

The Modular VCI (MC) chassis shall provide a tool supplier selected Protocol Expansion Connector (PEC) and an optional USB port connection inside the PES. The PEC may be used for an additional physical layer protocol hardware enhancement, while the optional USB interface could be used to insert a microprocessor based PEM enhancement.

The vehicle PES fulfils the requirement to connect to new vehicle communication technology in a cost effective manner. It also provides sufficient flexibility in the design of new vehicle protocol capability and connectivity to the Modular VCI (MC) chassis for best price and packaging.

8.5.2.3 Modular VCI (MC) chassis ground isolation

The Modular VCI (MC) chassis is not required to support ground isolation between the DLC connector and the host interface connector end if a handheld device is connected to the Modular VCI (MC) chassis.

If a host system is connected to the Modular VCI (MC) chassis, which is powered through an AC power outlet the Modular VCI (MC) chassis shall provide ground isolation between the vehicle DLC and the host interface connection.

For a Modular VCI (MC) chassis, ground isolation shall be maintained between the vehicle's chassis ground and signal ground (see 8.6.3.2). For a system consisting of multiple mechanically compliant VCI Protocol Modules, it is the system integrator's responsibility to ensure that this ground isolation is maintained.

8.5.2.4 Modular VCI (MC) chassis power supply requirements

It is the tool supplier's responsibility which voltage range, current and tolerances are supported by the power supply in the design of the Modular VCI (MC) chassis module. These requirements depend on the vehicle protocols and diagnostic connector specifications to be supported.

In addition, the requirements below apply.

- The amount of current drawn from the vehicle's diagnostic connector shall be limited to 4 A at 12 V d.c. (2 A at 24 V d.c.) for a Modular VCI (MC) chassis. If the Modular VCI (MC) chassis module uses signal ground for the power return, the current returned via the signal ground path shall comply with the specification for the vehicle's diagnostic connector (e.g. no more than 1,5 A for the ISO 15031-3 diagnostic connector).
- A Modular VCI (MC) chassis that is designed for operation on a vehicle with a 12 V d.c. (24 V d.c.) power supply at the diagnostic connector shall withstand the continuous supply of 36 V d.c. without any damage.

8.5.2.5 Modular VCI (MC) chassis vehicle communication port high impedance requirement

The Modular VCI (MC) chassis shall include high impedance state switches for each DLC serial communication data line except power and ground supply lines. This requirement supports the concept of vehicle communication protocol software selection as needed on a specific pin at the vehicle's diagnostic connector. The default state of the high impedance state switches at power down, power on and after a reset shall always be open (no electrical connection). The control of the high impedance state switches shall only be possible through the API function calls as specified in Part 2 (D-PDU API) and Part 3 (D-Server API) of the Modular VCI specifications.

NOTE When in the high impedance state, the switch can be subject to voltage spikes and other electrical disturbances, coming from the unused pins, exceeding those specified for the supported protocols. It is the tool supplier's responsibility to ensure proper electrical protection of the switch.

8.5.3 Modular VCI mechanical compliance API support

At a minimum, mechanical compliance requires applicability to Part 2 of the Modular VCI specification, which specifies the D-PDU API to be supported by the host interface protocol. This API provides a set of function calls to allow protocol independent message data content transfer between the host system software and the VCI protocol interface. An alternative configuration may include a Modular VCI server, which supports the Modular VCI - Part 3: D-Server API.

8.5.4 Modular VCI (MC) chassis usage requirements

The Modular VCI (MC) chassis usually operates in a single Modular VCI environment but is not limited to use in a "Y" cable configuration.

8.5.5 Modular VCI (MC) chassis design

8.5.5.1 Chassis housing

The Modular VCI (MC) chassis housing is required for a stand-alone use case when connected to the DLC cable. It is the tool supplier's responsibility to define dimensions, material and robustness of the chassis housing.

8.5.5.2 Built-in server

A Modular VCI chassis may be equipped with built-in server hardware. The server shall provide appropriate support of the D-Server API as specified in the Modular VCI - Part 3: D-Server API specification. In addition, the server software may provide various applications, Web services and compatible protocols.

8.5.5.3 Connector locations

It is the tool supplier's responsibility to determine the locations of the following connectors (minimum set) and the expansion slot at the Modular VCI chassis:

- vehicle DLC connector;
- host connector;
- external power supply;
- vehicle Protocol Expansion Slot (PES).

8.5.5.4 DLC connector type and pin assignment

The Modular VCI (MC) chassis shall be equipped with a vehicle DLC connector of type male HD26 (see 8.6.2). The pin assignment of the Modular VCI (MC) chassis DLC connector is specified in 8.6.3.

8.5.5.5 Host connection and pin assignment

The Modular VCI (MC) chassis shall be equipped with an Ethernet connection to the host system. Other optional connections like Wireless Interface via PCMCIA, Compact Flash Socket, USB, etc. may be supported.

The Modular VCI (MC) chassis shall contain an RJ-45 Fast Ethernet connector. This is the industry standard 8-pin Ethernet connector with the same pin-out as the pin-out for Ethernet connectors on PCs. Therefore, a crossover cable is required if the module is to be connected directly to a PC.

8.6 Data Link Connector (DLC) cable and connector

8.6.1 Data Link Connector (DLC) cable and adapter requirements

The design of the DLC cable and adapter is the tool supplier's responsibility. There is no requirement to use an adapter concept in conjunction with the DLC cable. The overall length of the DLC cable, including the connectors at both ends of the cable, shall not exceed the length requirements specified in the vehicle communication protocol specifications implemented in the Modular VCI (MC) chassis.

8.6.2 Modular VCI Data Link Connector (DLC) connector type

An Electrically Compliant (EC) and a Mechanically Compliant (MC) VCI Protocol Module shall use the industry standard, 26-pin, High Density D-Sub Connector, normally referred to as an HD26 connector, for the interface to the vehicle's Data Link Connector (DLC). The connector that is mounted to the VCI Protocol Module or Chassis Module shall be the male version of the connector (pins), while the mating connector on the cable assembly shall be female (sockets). The connector mounted to the VCI Protocol Module shall include two jackscrews with standard #4-40 threads to be used for locking the DLC Cable to the VCI Protocol Module or an appropriate alternative as shown in Figure 11.

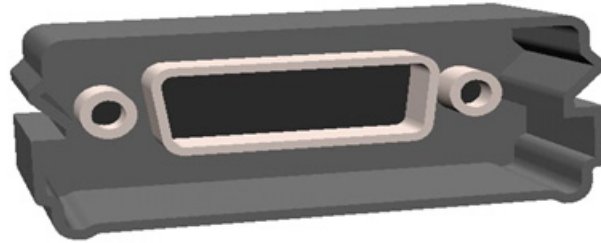

Figure 11 — Protected industry standard, 26-pin, High Density D-Sub Connector example

The DLC connector and pin assignment is specified in 8.6.3.

8.6.3 Data Link Connector (DLC) connector and pin assignment

8.6.3.1 Modular VCI chassis DLC connector pin assignment

The Modular VCI (MC) chassis DLC connector routes all signals, including the power supply pins from the DLC connector, to the vehicle protocol interfaces. Table 3 specifies all pin assignments. The right column indicates which of the pins are compatible with the ISO 15031-3/SAE J1962 diagnostic connector standard.

Table 3 — Pin assignment of VCI (EC) Protocol Module and Modular VCI (MC) chassis DLC connector

26 Pin	Pin mnemonic	Description of DLC connector	ISO 15031-3/ SAE J1962 compatible
1	Manf_Discret_1	ISO 15031-3/SAE J1962 Manufacturer Discretionary	yes
2	SAE J1850+	OBD_J1850 bus positive line	yes
3	Manf_Discret_3	ISO 15031-3/SAE J1962 Manufacturer Discretionary	yes
4	PwrGnd	Chassis power ground	yes
5	SigGnd	Signal communication ground	yes
6	OBD_CAN+	OBD_CAN_H line of ISO 15765-4	yes
7	OBD_K_Line	OBD_K line of ISO 9141-2 and ISO 14230-4	yes
8	Manf_Discret_8	ISO 15031-3/SAE J1962 Manufacturer Discretionary	yes
9	Manf_Discret_9	ISO 15031-3/SAE J1962 Manufacturer Discretionary	yes
10	OBD_J1850-	OBD_J1850 bus negative line	yes
11	Manf_Discret_11	ISO 15031-3/SAE J1962 Manufacturer Discretionary	yes
12	Manf_Discret_12	ISO 15031-3/SAE J1962 Manufacturer Discretionary	yes
13	Manf_Discret_13	ISO 15031-3/SAE J1962 Manufacturer Discretionary	yes
14	OBD_CAN-	OBD_CAN_L line of ISO 15765-4	yes
15	OBD_L_Line	OBD_L line of ISO 9141-2 and ISO 14230-4	yes
16	Ubat _{vehicle}	Permanent positive voltage from vehicle	yes
17	ADAPTER_ID_0	Manufacturer specific cable and adapter identification	no
18	ADAPTER_ID_1	Manufacturer specific cable and adapter identification	no
19	SPI_OUT	Optional control line of an external "Cable VCI". If not used this pin is reserved and shall not be used for any other purpose.	no
20	SPI_IN	Optional control line of an external "Cable VCI". If not used this pin is reserved and shall not be used for any other purpose.	no
21	SPI_CLK	Optional control line of an external "Cable VCI". If not used this pin is reserved and shall not be used for any other purpose.	no
22	SPI_EXT_CS	Optional external chip select control line of an external "Cable VCI". If not used this pin is reserved and shall not be used for any other purpose.	no
23	PWR_OUT_5V+	Power supply positive 5 V for "Cable VCI"	no
24	SW_UBATT	Switched Vehicle Battery Voltage (Ignition on/off)	no
25	Reserved	This pin is reserved by this document and shall not be used for any manufacturer discretionary use.	no
26	PWR_OUT_GND	Power supply ground for "Cable VCI"	no

8.6.3.2 Minimum DLC adapter identification requirements

Pins 17 and 18 are allocated to allow for the option of electrical identification of an external cable adapter. The pins allow voltages of between 0 V and 5 V, and either digital or analogue identification methods.

The equipment shall tolerate a short to either 0 V or 5 V minimum.

The SPI interface could be used as an alternative method of identifying an external adapter.

8.6.3.3 Minimum DLC SPI interface requirements

Pins 19, 20, 21 and 22 are allocated to allow for the option of communication to an external cable adapter.

The pins allow voltages of between 0 V and 5 V.

The equipment shall tolerate a short to either 0 V or 5 V minimum.

8.6.3.4 Minimum DLC power out requirements

This pin is defined by the Modular VCI supplier to optionally provide 5 V power to an external cable/adapter.

It is the responsibility of the VCI supplier to protect this output from over-current conditions

8.6.4 Ground connections for DLC connector

For interfacing to vehicles that use the ISO 15031-3 connector, ground connections are provided via pin 4 (Chassis Ground) and pin 5 (Signal Ground). An EC and MC compliant MVCI Protocol Module shall comply with all requirements of ISO 15031-3 with respect to the usage of these ground signals. These specifications require that the signal ground contact be used by the external test equipment as the signal ground reference for vehicle communication transceivers. The specifications also allow the external test equipment (MVCI Protocol Module in this case) to use either ground as the power ground return subject to a limit of 1,5 A that can be returned through the Signal Ground contact (pin 5).

An additional requirement is that the two grounds (pins 4 and 5) shall not be connected together within the MVCI Protocol Module. ISO 15031-3 and SAE J1962) specifies that the minimum impedance shall be 1 M Ω between each of the following:

- External test equipment connector contacts 4 and 5,
- External test equipment connector contact 4 and the external surface of the external test equipment,
- External test equipment connector contact 5 and the external surface of the external test equipment.

For systems consisting of more than a single MVCI Protocol Module, it is the responsibility of the system integrator to ensure that these requirements are met for the entire system.

8.6.5 Optional legacy DLC connector and pin assignment

The purpose of a legacy DLC connector is to provide the capability to connect an existing DLC cable from a legacy scan tool or VCI in order to ease the mechanical and electrical access to the diagnostic connector of legacy vehicles with the Modular VCI. The legacy DLC connector is optional. The legacy DLC connector pin assignment is not part of this part of ISO 22900 and can be chosen by the tool supplier or OEM to achieve backward compatibility with an existing DLC cable design.

8.6.6 “Y” and “splitter” type DLC cables

8.6.6.1 “Y” type DLC cable design

The “Y” type DLC cable design consists of a cable [A] with a male connector [B] and two female connectors [C]. The “Y” end [C] of the DLC cable shall have the female mating connectors [C] to the MVCI (EC) Protocol Modules and terminate in the MVCI (EC) Protocol Module connector.

The DLC cable [D] consists of a male connector [B], which connects into the DLC connector with a female connector [C]. The other end of the DLC cable [D] has a female connector [C], which connects into the “Y” type DLC cable (male connector [B]). This design allows for two usage scenarios:

- a) use the DLC cable [D] directly between DLC connector and one MVCI (EC) Protocol Module;
- b) use a “Y” type DLC cable between the DLC cable [D] and MVCI (EC) Protocol Modules.

The “Y” type DLC cable [A] shall not exceed a maximum length of 0,25 m measured at the end of connector [C] and [B], as shown in Figure 12.

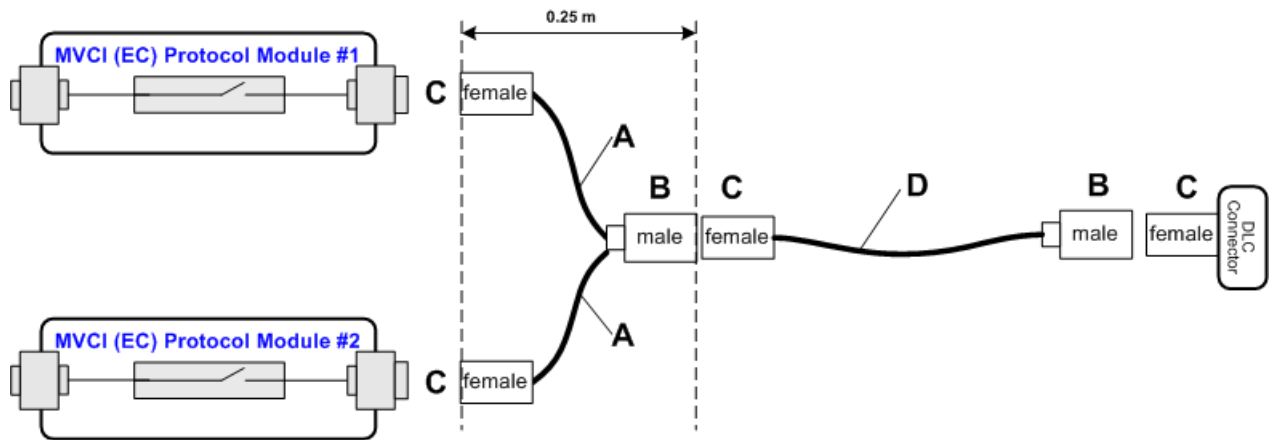

Key

- A “Y” type DLC cable
- B male connector of “Y” type cable and DLC cable
- C female connector of DLC adapter, DLC cable and of “Y” type cable which connects to the MVCI (EC) Protocol Module #1, #2
- D DLC cable

NOTE Using the “Y” type DLC cable in a mechanically compliant Modular VCI configuration requires connector [C] to be a female DB26 pin industry standard connector.

Figure 12 — “Y” type DLC cable example

8.6.6.2 “Splitter” type DLC cable design

The “splitter” type DLC cable design consists of a cable [A] with a male connector [B] and three female connectors [C]. The “Y” end [C] of the DLC cable shall have the female mating connectors [C] to the MVCI (EC) Protocol Modules and terminate in the MVCI (EC) Protocol Module connector.

The DLC cable [D] consists of a male connector [B], which connects into the DLC connector with a female connector [C]. The other end of the DLC cable [D] has a female connector [C], which connects into the “Y” type DLC cable (male connector [B]). This design allows for two usage scenarios:

- a) use the DLC cable [D] directly between DLC connector and one MVCI (EC) Protocol Module;
- b) use a “splitter” type DLC cable between the DLC cable [D] and MVCI (EC) Protocol Modules.

The “splitter” type DLC cable [A] shall not exceed a maximum length of 0,25 m measured at the end of connector [C] and [B], as shown in Figure 13.

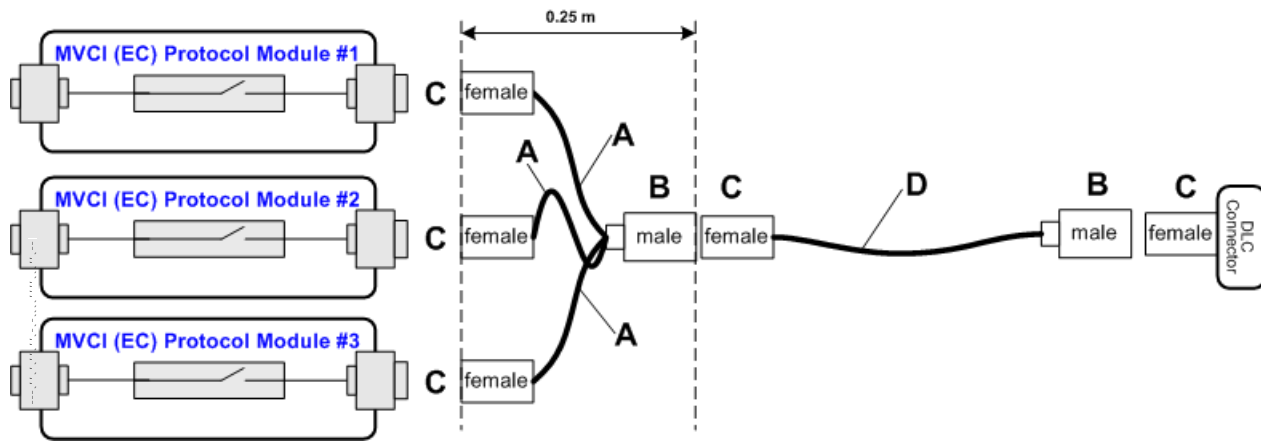

Key

- A “Splitter” type DLC cable
- B male connector of “Splitter” type cable and DLC cable
- C female connector of DLC adapter, DLC cable and of “Splitter” type cable which connects to the MVCI (EC) Protocol Module #1, #2
- D DLC cable

NOTE Using the “Splitter” type DLC cable in a mechanically compliant Modular VCI configuration requires connector [C] to be a female DB26 pin industry standard connector.

Figure 13 — “Splitter” type DLC cable example

9 Programmable power supply

The MVCI Protocol Module shall be capable of supplying a programmable power supply between 5,0 V d.c. and 24 V d.c. to one of the following pins (6, 9, 11, 12, 13 or 14) on the ISO 15031-3 diagnostic connector, or to an auxiliary pin which would need to be connected to the vehicle via a cable that is unique to the vehicle. The auxiliary pin on the MVCI Protocol Module shall be an insulated female banana jack that accepts a standard 0,175 in¹⁾ diameter banana plug as the auxiliary pin for connection of programming voltage power supply to a vehicle specific connector on the vehicle. Short to ground capability on pin 15 is also required.

The following requirements shall be met by the programming voltage power supply:

- a) a minimum of 5,0 V d.c.,
- b) a maximum of 24,0 V d.c.,
- c) a resolution of 0.1 V d.c.,
- d) an accuracy of ± 2 % of the requested voltage,
- e) a maximum source current of 150 mA,
- f) a maximum sink current of 300 mA (only for short to ground of pin 15),

1) 1 in = 25,4 mm.

- g) a maximum of 1 ms settling time (required for SCI protocol only; see SAE J2610 Information Report),
- h) the pin assignment shall be software selectable by the D-PDU API.

10 General electrical requirements

Certification requirements (e.g. CE, EMC, UL, CSA, etc.) for the appropriate national markets are the responsibility of the tool supplier.

Impedance, voltage and short protection are specified by each vehicle communication protocol, e.g. ISO 15765-4.

11 General environmental durability requirements

Environmental durability requirements are the responsibility of the tool supplier.

Bibliography

- [1] ISO 7637-2, *Road Vehicles — Electrical disturbances from conduction and coupling — Part 2: Electrical transient conduction along supply lines only*
- [2] ISO/IEC 8802-3, *Information technology — Telecommunications and information exchange between systems — Local and metropolitan area networks — Specific requirements — Part 3: Carrier sense multiple access with collision detection (CSMA/CD) access method and physical layer*
- [3] ISO/IEC 8859-1, *Information technology — 8-bit single-byte coded graphic character sets — Part 1: Latin alphabet No. 1*
- [4] ISO/IEC 8859-2, *Information technology — 8-bit single-byte coded graphic character sets — Part 2: Latin alphabet No. 2*
- [5] ISO 9141-2, *Road vehicles — Diagnostic systems — Part 2: CARB requirements for interchange of digital information*
- [6] ISO 14229-1, *Road vehicles — Unified diagnostic services (UDS) — Part 1: Specification and requirements*
- [7] ISO 14230 (all parts), *Road vehicles — Diagnostic systems — Keyword protocol 2000*
- [8] ISO 15031-4, *Road vehicles — Communication between vehicle and external equipment for emissions-related diagnostics — Part 4: External test equipment*
- [9] ISO 15031-5, *Road vehicles — Communication between vehicle and external equipment for emissions-related diagnostics — Part 5: Emissions-related diagnostic services*
- [10] ISO 15765 (all parts), *Road vehicles — Diagnostics on Controller Area Networks (CAN)*
- [11] ISO 16750-2, *Road vehicles — Environmental conditions and testing for electrical and electronic equipment — Part 2: Electrical loads*
- [12] ISO 22900-2, *Road vehicles — Modular vehicle communication interface (MVCI) — Part 2: Diagnostic protocol data unit application programming interface (D-PDU API)*
- [13] ISO 22900-3, *Road vehicles — Modular vehicle communication interface (MVCI) — Part 3: Diagnostic server application programming interface (D-Server API)*
- [14] ISO 22901-1, *Road vehicles — Open diagnostic data exchange — Part 1: Data model specification*
- [15] ISO/PAS 27145 (all parts), *Road vehicles — Implementation of WWH-OBD communication requirements*
- [16] SAE J1587, *Electronic Data Interchange Between Microcomputer Systems in Heavy-Duty Vehicle Applications*
- [17] SAE J1708, *Serial Data Communications Between Microcomputer Systems in Heavy-Duty Vehicle Applications*
- [18] SAE J1850, *Class B Data Communications Network Interface*
- [19] SAE J1939, *Recommended Practice for a Serial Control and Communications Vehicle Network*
- [20] SAE J1962, *Diagnostic Connector Equivalent to ISO/DIS 15031-3:December 14, 2001*

- [21] SAE J2190, *Enhanced E/E Diagnostic Test Modes*
- [22] SAE J2534-1, *Recommended Practice for Pass-Thru Vehicle Programming*
- [23] SAE J2610, *Serial Data Communication Interface*
- [24] SAE J2740, *General Motors UART Serial Data Communications*
- [25] SAE J2809, *Honda Diagnostic Serial Data Link Protocol — ABS/VSA System*
- [26] OTG, *On-The-Go Supplement to the USB 2.0 Specification*
- [27] USB, *Universal Serial Bus*
- [28] IEEE 802, *Telecommunications and Information Exchange Between Systems*

ICS 43.040.15

Price based on 29 pages