**Determination of the resistance to jet
fires of passive fire protection
materials —**

**Part 1:
General requirements**

*Détermination de la résistance aux feux propulsés des matériaux de
protection passive contre l'incendie —*

Partie 1: Exigences générales



Reference number
ISO 22899-1:2007(E)

© ISO 2007

PDF disclaimer

This PDF file may contain embedded typefaces. In accordance with Adobe's licensing policy, this file may be printed or viewed but shall not be edited unless the typefaces which are embedded are licensed to and installed on the computer performing the editing. In downloading this file, parties accept therein the responsibility of not infringing Adobe's licensing policy. The ISO Central Secretariat accepts no liability in this area.

Adobe is a trademark of Adobe Systems Incorporated.

Details of the software products used to create this PDF file can be found in the General Info relative to the file; the PDF-creation parameters were optimized for printing. Every care has been taken to ensure that the file is suitable for use by ISO member bodies. In the unlikely event that a problem relating to it is found, please inform the Central Secretariat at the address given below.



COPYRIGHT PROTECTED DOCUMENT

© ISO 2007

All rights reserved. Unless otherwise specified, no part of this publication may be reproduced or utilized in any form or by any means, electronic or mechanical, including photocopying and microfilm, without permission in writing from either ISO at the address below or ISO's member body in the country of the requester.

ISO copyright office
Case postale 56 • CH-1211 Geneva 20
Tel. + 41 22 749 01 11
Fax + 41 22 749 09 47
E-mail copyright@iso.org
Web www.iso.org

Published in Switzerland

Contents

Page

Foreword.....	v
Introduction	vi
1 Scope	1
2 Normative references	1
3 Terms and definitions.....	1
4 Principle.....	3
5 Test configurations.....	3
5.1 General.....	3
5.2 Internal configuration	5
5.3 External configuration.....	5
6 Construction of the test items and substrates	5
6.1 General.....	5
6.2 Material	5
6.3 Nozzle.....	5
6.4 Flame re-circulation chamber.....	6
6.5 Protective chamber.....	7
6.6 Panel test specimens (internal configuration).....	8
6.7 Structural steelwork test specimens (internal configuration)	9
6.8 Tubular section test specimens (external configuration).....	12
6.9 Assembly test specimens	13
7 Passive fire protection materials	15
7.1 General.....	15
7.2 Panel test specimens	15
7.3 Structural steelwork test specimens	16
7.4 Tubular section test specimens	16
7.5 Assembly specimens	17
8 Instrumentation.....	19
8.1 General.....	19
8.2 Panel test specimens	19
8.3 Structural steelwork test specimens	19
8.4 Tubular section test specimens	21
8.5 Assembly specimens	22
9 Test apparatus and conditions.....	24
9.1 Nozzle geometry and position.....	24
9.2 Fuel.....	26
9.3 Test environment.....	26
10 Test procedure	26
11 Repeatability and reproducibility	29
12 Uncertainty of measurement	29
13 Test report	30
14 Practical application of test results	31
14.1 General.....	31
14.2 Performance criteria	31
14.3 Factors affecting the validity of the test.....	32

15	Classification (optional)	33
15.1	General	33
15.2	Type of fire	33
15.3	Type of application	33
15.4	Critical temperature rise	33
15.5	Period of resistance	33
15.6	Example of application of the rating	34
Annex A	(normative) Methods of fixing thermocouples	35
Annex B	(informative) Example test report	37
Bibliography	40

Foreword

ISO (the International Organization for Standardization) is a worldwide federation of national standards bodies (ISO member bodies). The work of preparing International Standards is normally carried out through ISO technical committees. Each member body interested in a subject for which a technical committee has been established has the right to be represented on that committee. International organizations, governmental and non-governmental, in liaison with ISO, also take part in the work. ISO collaborates closely with the International Electrotechnical Commission (IEC) on all matters of electrotechnical standardization.

International Standards are drafted in accordance with the rules given in the ISO/IEC Directives, Part 2.

The main task of technical committees is to prepare International Standards. Draft International Standards adopted by the technical committees are circulated to the member bodies for voting. Publication as an International Standard requires approval by at least 75 % of the member bodies casting a vote.

Attention is drawn to the possibility that some of the elements of this document may be the subject of patent rights. ISO shall not be held responsible for identifying any or all such patent rights.

ISO 22899-1 was prepared by Technical Committee ISO/TC 92, *Fire safety*, Subcommittee SC 2, *Fire containment*.

ISO 22899 consists of the following parts, under the general title *Determination of the resistance to jet fires of passive fire protection materials*:

— *Part 1: General requirements*

Further parts of ISO 22899 are planned for future publication.

Introduction

The test described in the procedure described in this part of ISO 22899 is one in which some of the properties of passive fire protection materials can be determined. This test is designed to give an indication of how passive fire protection materials will perform in a jet fire. The dimensions of the test specimen may be smaller than typical items of structure and plant and the release of gas may be substantially less than that which might occur in a credible event. However, individual thermal and mechanical loads imparted to the passive fire protection material, from the jet fire defined in the procedure described in this part of ISO 22899, have been shown to be similar to those by large-scale jet fires resulting from high-pressure releases of natural gas.

NOTE 1 Guidance on the applicability of the test will be covered in a future part of ISO 22899.

Although the method specified has been designed to simulate some of the conditions that occur in an actual jet fire, it cannot reproduce them all exactly and the thermal and mechanical loads do not necessarily coincide. The results of this test do not guarantee safety but may be used as elements of a fire risk assessment for structures or plant. This should also take into account all the other factors that are pertinent to an assessment of the fire hazard for a particular end use. The test is not intended to replace the hydrocarbon fire resistance test (ISO/TR 834-3/EN 1363-2^[2]) but is seen as a complementary test.

NOTE 2 Users of this part of ISO 22899 are advised to consider the desirability of third-party certification/inspection/testing of product conformity with this part of ISO 22899.

Determination of the resistance to jet fires of passive fire protection materials —

Part 1: General requirements

CAUTION — the attention of all persons concerned with managing and carrying out this fire resistance test is drawn to the fact that fire testing may be hazardous and that there is a possibility that toxic and/or harmful smoke and gases may be evolved during the test. Mechanical and operational hazards may also arise during the construction of the test elements or structures, their testing and disposal of test residues.

An assessment of all potential hazards and risks to health shall be made and safety precautions shall be identified and provided. Appropriate training shall be given to relevant personnel.

1 Scope

This part of ISO 22899 describes a method of determining the resistance to jet fires of passive fire protection materials and systems. It gives an indication of how passive fire protection materials behave in a jet fire and provides performance data under the specified conditions.

It does not include an assessment of other properties of the passive fire protection material such as weathering, ageing, shock resistance, impact or explosion resistance, or smoke production.

2 Normative references

ISO 630:1995, *Structural steels — Plates, wide flats, bars, sections and profiles*

ISO/TR 834-3, *Fire-resistance tests — Elements of building construction — Part 3: Commentary on test method and test data application*

ISO 13702, *Petroleum and natural gas industries — Control and mitigation of fires and explosions on offshore production installations — Requirements and guidelines*

3 Terms and definitions

For the purposes of this document, the following terms and definitions apply.

3.1

assembly

unit or structure composed of a combination of materials or products, or both

3.2

cellulosic fire

fire involving combustible material such as wood, paper, furniture, etc.

- 3.3**
critical temperature
maximum temperature that the equipment, assembly or structure to be protected may be allowed to reach
- 3.4**
critical time
minimum time required to reach the critical temperature
- 3.5**
fire barrier
separating element that resists the passage of flame and/or heat and/or effluents for a period of time under specified conditions
- 3.6**
fire resistance
ability of an item to fulfil, for a stated period of time, the required stability and/or integrity and/or thermal insulation, and/or other expected duty (reaching the critical temperature) specified in a standard fire-resistance test
- 3.7**
fire test
procedure designed to measure or assess the performance of a material, product, structure or system to one or more aspects of fire
- 3.8**
flame re-circulation chamber
mild steel box, open at the front, into which the jet fire is directed giving a re-circulating flame resulting in a fireball
- NOTE Materials other than mild steel may be used when appropriate.
- 3.9**
integrity
ability of a separating element, when exposed to fire on one side, to prevent the passage of flames and hot gases or occurrence of flames on the unexposed side, for a stated period of time in a standard fire resistance test
- 3.10**
intermediate-scale test
test performed on an item of medium dimensions
- NOTE A test performed on an item of which the maximum dimension is between 1 m and 3 m is usually called "an intermediate-scale test". This part of ISO 22899 describes an intermediate-scale jet fire test.
- 3.11**
jet fire
ignited discharge of propane vapour under pressure
- 3.12**
jet nozzle
assembly from which the flammable material issues
- 3.13**
outside specimen diameter
specimen diameter measured to the outer surface of the passive fire protection system on a tubular specimen
- 3.14**
passive fire protection
coating or cladding arrangement or free-standing system which, in the event of fire, will provide thermal protection to restrict the rate at which heat is transmitted to the object or area being protected

NOTE The term passive is used to distinguish the systems tested, including those systems that react chemically e.g. intumescent, from active systems such as water deluge.

3.15

passive fire protection material

coating or cladding that, in the event of a fire, will provide thermal protection to restrict the rate at which heat is transmitted to the object or area being protected

3.16

passive fire protection system

removable jacket or inspection panel, cable transit system, pipe penetration seal or other such system that, in the event of a fire, will provide thermal protection to restrict the rate at which heat is transmitted to the object or area being protected

3.17

penetration seal

system used to maintain the fire resistance of a separating element at the position where there is provision for services to pass through the separating element

3.18

pool fire

combustion of flammable or combustible hydrocarbon liquid spilled and retained on a surface

3.19

protective chamber

mild steel box, open at the front and back, which is designed to be attached to the rear of the flame re-circulation chamber to shield the rear of the flame re-circulation chamber from environmental influences

NOTE A protective chamber is not required for tubular section tests but may be used to provide additional stability to the flame re-circulation chamber.

4 Principle

The method provides an indication of how passive fire protection materials perform in a jet fire that may occur, for example, in petrochemical installations. It aims at simulating the thermal and mechanical loads imparted to passive fire protection material by large-scale jet fires (see Bibliography [3]) resulting from high-pressure releases of flammable gas, pressure liquefied gas or flashing liquid fuels. Jet fires give rise to high convective and radiative heat fluxes as well as high erosive forces. To generate both types of heat flux in sufficient quantity, a $0,3 \text{ kg s}^{-1}$ sonic release of gas is aimed into a shallow chamber, producing a fireball with an extended tail. The flame thickness is thereby increased and hence so is the heat radiated to the test specimen. Propane is used as the fuel since it has a greater propensity to form soot than does natural gas and can therefore produce a flame of higher luminosity. High erosive forces are generated by the release of the sonic velocity gas jet 1 m from specimen surface.

5 Test configurations

5.1 General

There are two basic configurations under which the test can be operated:

- a) an internal configuration where one or more of the inner faces of the box incorporates the test construction;
- b) an external configuration where the test construction is installed on supports in front of the box.

These two alternative configurations are shown in Figures 1 and 2.

Dimensions in millimetres

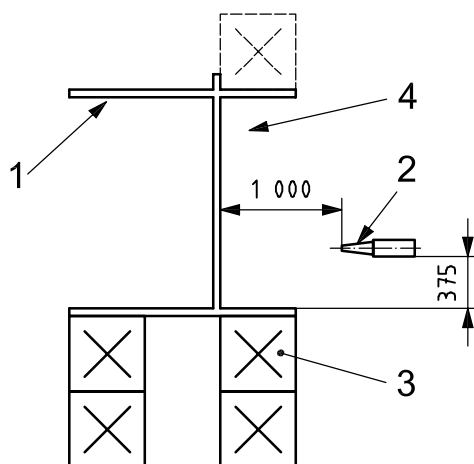

Key

- 1 protective chamber
- 2 jet nozzle
- 3 supports
- 4 flame re-circulation chamber either with coated inner surfaces or with the rear face replaced by a panel to form the test construction

Figure 1 — Layout for internal configuration

Dimensions in millimetres

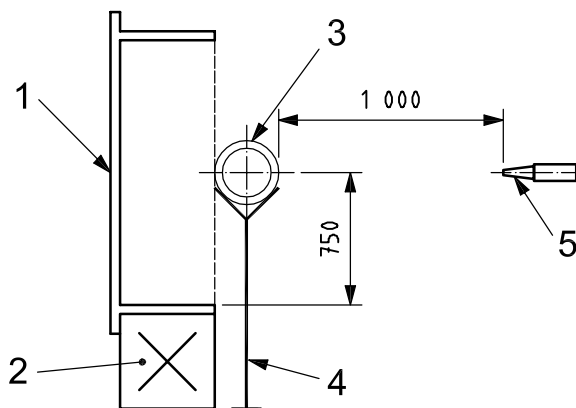

Key

- 1 flame re-circulation chamber
- 2 flame re-circulation chamber support
- 3 test construction
- 4 test construction support
- 5 jet nozzle

Figure 2 — Layout for external configuration

5.2 Internal configuration

The internal test configuration is used for determining the jet fire resistance of:

- a) protection systems for plane surfaces;
- b) protection systems for edge features;
- c) bulkheads and other separating elements;
- d) penetration systems used in conjunction with bulkheads.

5.3 External configuration

The external test configuration is used for determining the jet fire resistance of protected hollow sections or assemblies mounted on hollow sections.

6 Construction of the test items and substrates

6.1 General

The key items required for the test are the jet release nozzle, the flame re-circulation chamber and a protective chamber. These items are all required for the internal configurations of the test and the test specimen forms all or part of the flame re-circulation chamber. In the external configurations of the test, the flame re-circulation chamber is only used to help produce the fireball and it is not necessary to use the protective chamber.

6.2 Material

The material normally used is 10 mm thick steel plate complying with ISO 630:1995, Grade Fe 430. All welded construction shall be used and all welds shall be 5 mm fillet and continuous unless otherwise stated. All dimensions are in millimetres and, unless otherwise stated, the following tolerances shall be used:

— whole number	$\pm 1,0$ mm
— decimal to point ,0	$\pm 0,4$ mm
— decimal to point ,00	$\pm 0,2$ mm
— angles	$\pm 0' 30''$
— radii	$\pm 0,4$ mm

6.3 Nozzle

The fuel is released towards the specimen from a nozzle. The tapered, converging nozzle shall be of length 200 ± 1 mm, inlet diameter $52 \pm 0,5$ mm and outlet diameter $17,8 \pm 0,2$ mm. Figure 3 shows the details of construction. The nozzle shall be constructed of heat resistant stainless steel. Provisions shall be made for fitting a sighting device.

The side, top and bottom walls of the flame re-circulation chamber shall be constructed from mild steel of 10 mm thickness. The rear wall of the chamber shall either be constructed of 10 mm thick steel welded to the sides of the chamber or of a panel bolted on to form the rear wall. If the substrate material is not steel or the substrate thickness is not 10 mm, the material and thickness used shall be stated in the test report. The details of construction of the flame re-circulation chamber are given in Figure 5.

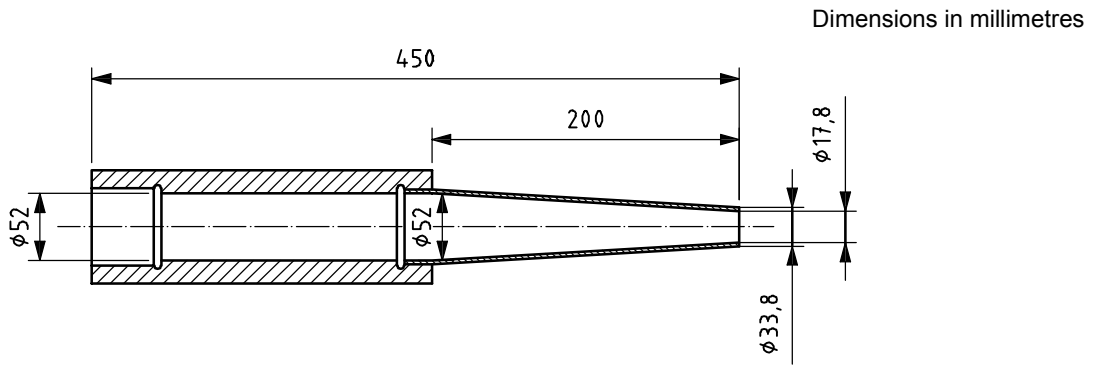
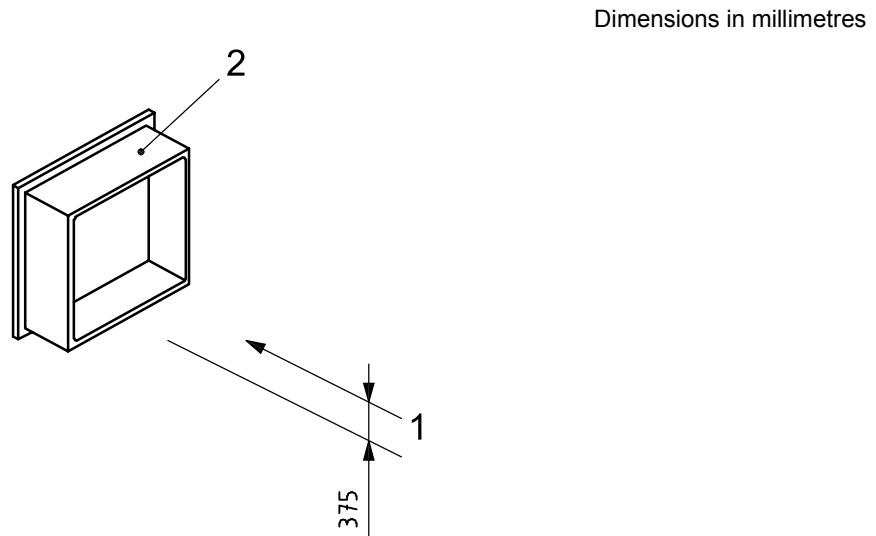

Figure 3 — Nozzle

6.4 Flame re-circulation chamber

The flame re-circulation chamber, having nominal internal dimensions 1 500 mm × 1 500 mm × 500 mm, shall be used for each test. The chamber is flanged at the rear to allow bolting on of a panel when required and attachment, by bolting or clamping, of the protective chamber when required. A general view of the flame re-circulation chamber is shown in Figure 4.



Key

- 1 jet position
- 2 flame re-circulation chamber

Figure 4 — General view of flame re-circulation chamber

Details of the flange construction, apart from the hole spacing, are not given as one of two methods may be used.

- a) The flanges may be constructed by welding L-section steel to the rear of each wall.
- b) For structural steelwork specimens, the rear wall may be constructed by continuously welding a 1 620 mm × 1 620 mm plate on to the rear of the flame re-circulation chamber and drilling holes at the appropriate locations in the plate extending beyond the sides of the chamber.

Inner walls that do not form part of the specimen, e.g. the sidewalls in a panel test, shall be protected from distortion by a ceramic board insulation material or other suitable form of passive fire protection material.

NOTE If the substrate is not steel, the material used for construction of the specimen should be at the discretion of the test laboratory and any third-party certifying body.

Dimensions in millimetres

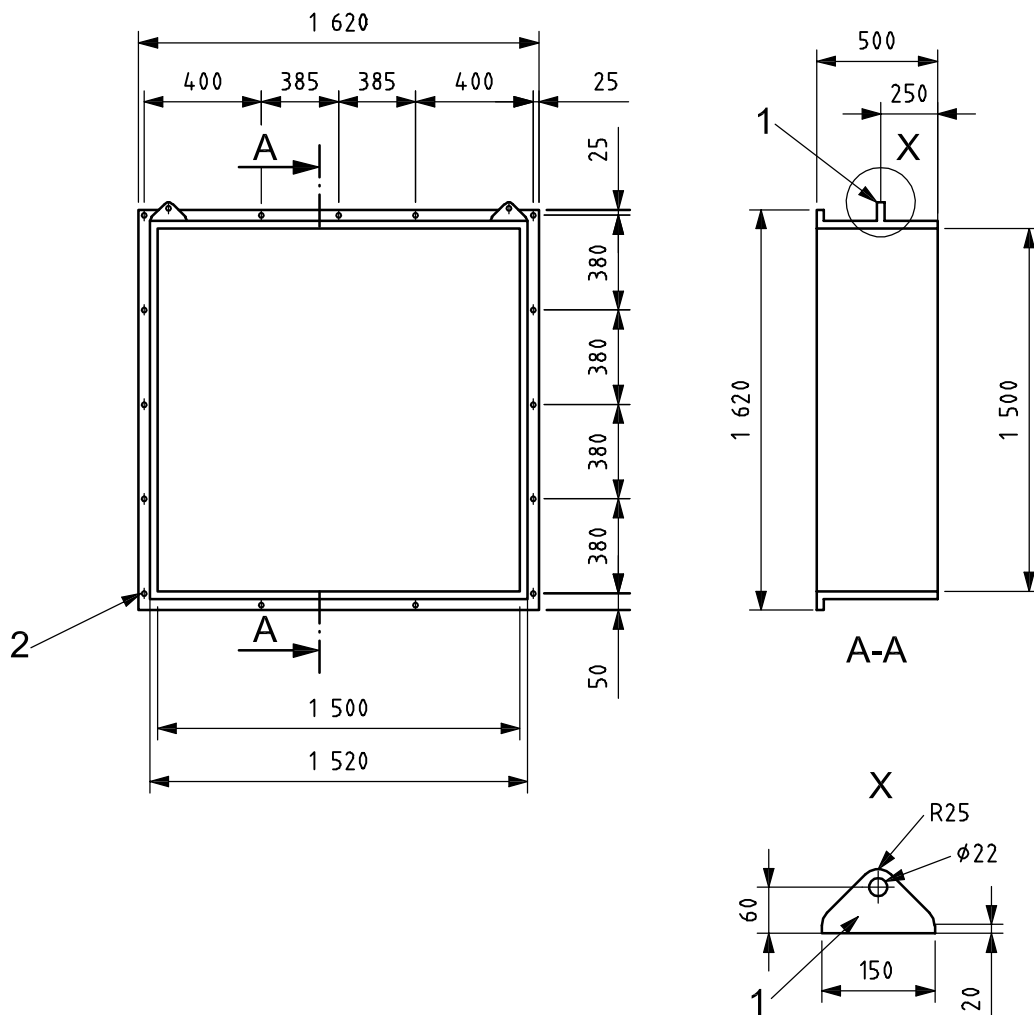

Key

- 1 lifting lug, 25 mm thick machined steel
- 2 sixteen holes drilled, $\phi 18$

Figure 5 — Construction of flame re-circulation chamber

6.5 Protective chamber

The protective chamber (nominal internal dimensions 1 500 mm \times 1 500 mm \times 1 000 mm) is used to shield the rear of the flame re-circulation chamber from environmental influences in the internal configuration of the test. It shall generally be constructed from mild steel of 10 mm thickness and shall be open at the front and back and flanged at the front to allow fitting to the rear of the flame re-circulation chamber with no visible air gaps.

A general view of the protective chamber is shown in Figure 6 and details of construction in Figure 7.

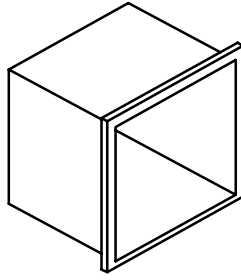
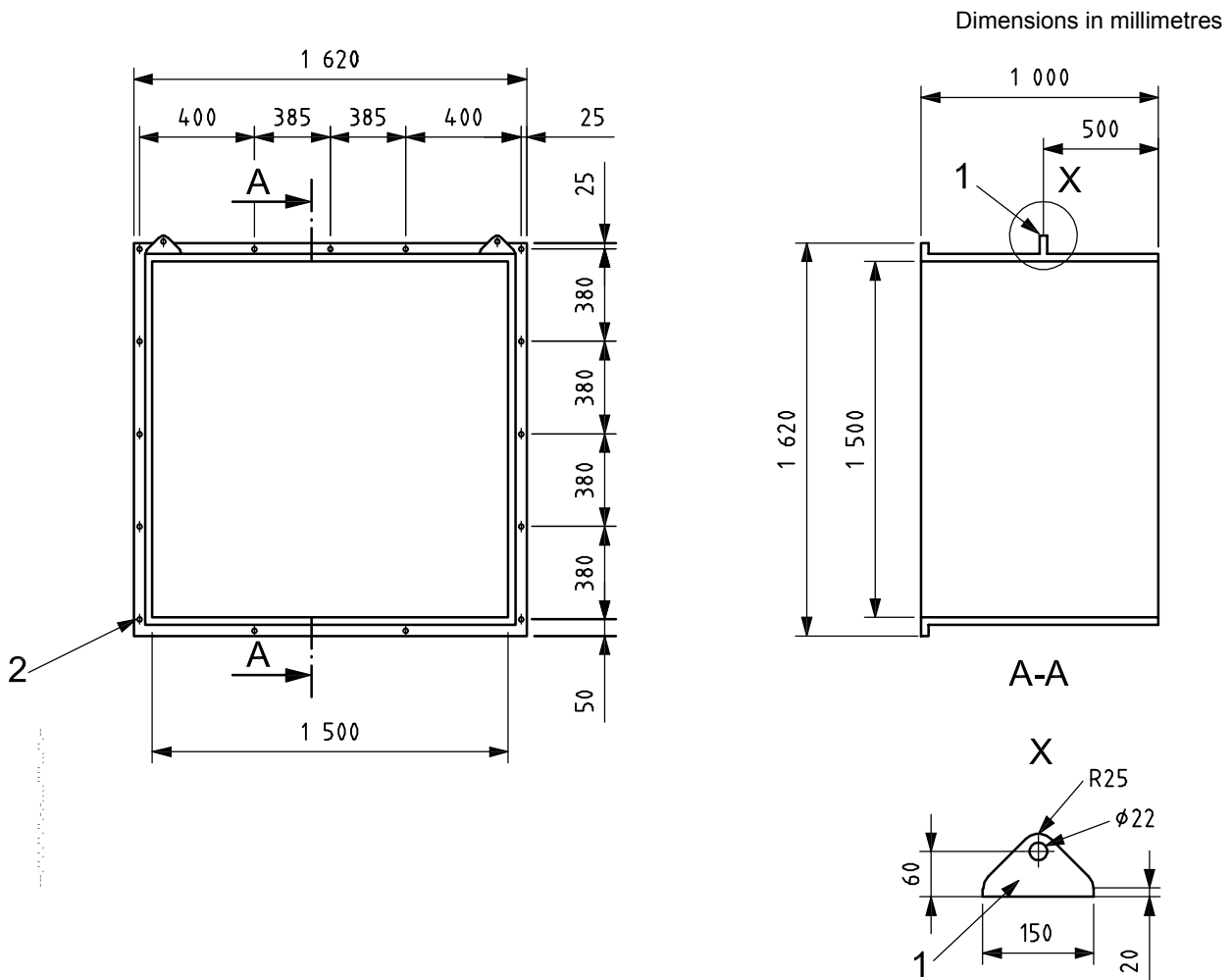

Figure 6 — General view of protective chamber



Key

- 1 lifting lug, 25 mm thick machined steel
- 2 sixteen holes drilled, \varnothing 18

Figure 7 — Construction of protective chamber

6.6 Panel test specimens (internal configuration)

The panel test specimen shall consist of a flame re-circulation chamber, with the rear wall replaced by the panel to be tested. The panel is sandwiched between the flame re-circulation chamber and the protective chamber as illustrated in Figure 8. The connection between the panel and the flame re-circulation chamber shall be gas tight. The method of mounting depends on the type of passive fire protection as described in 7.1.

Dimensions in millimetres

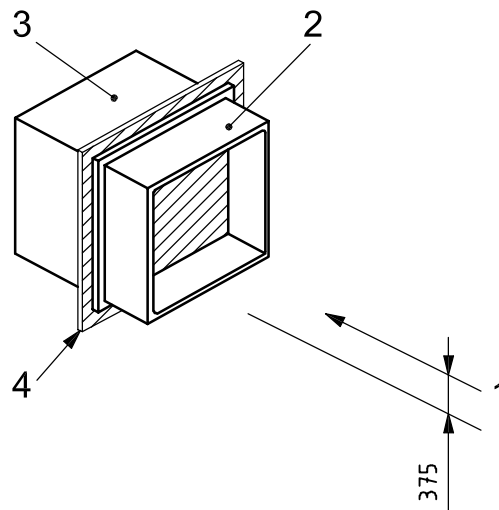
**Key**

- 1 jet position
- 2 flame re-circulation chamber
- 3 protective chamber
- 4 panel

Figure 8 — Position of panel

For cases that simulate steelwork with no corners or edge features; or cylindrical vessels, pipes and tubular sections of outside diameter greater than 500 mm, a 1 620 mm × 1 620 mm panel shall be constructed from 10 mm thick steel. The details of construction are shown in Figure 9. If the substrate material is not steel or the thickness is not 10 mm, the material and thickness used shall be stated in the test report.

6.7 Structural steelwork test specimens (internal configuration)

The structural steelwork test specimen shall consist of the flame re-circulation chamber with the addition of a 20 mm thick central web, 250 mm deep, to simulate corner or edge features such as stiffening webs or edges of "I" beams. A general view of the test specimen is illustrated in Figure 10.

Dimensions in millimetres

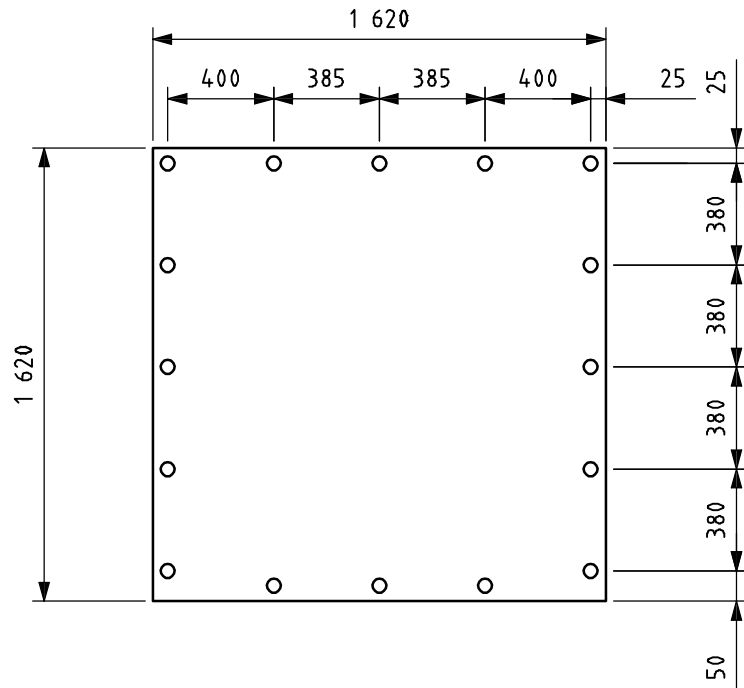
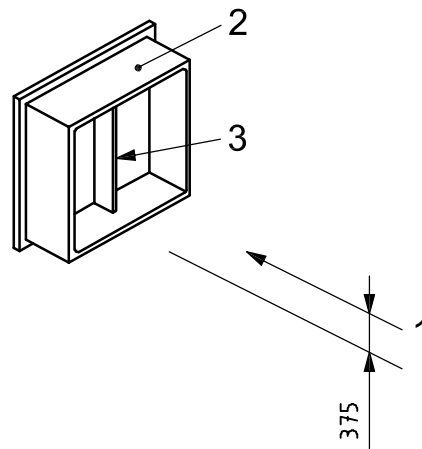

Figure 9 — Construction of panels

Dimensions in millimetres



Key

- 1 jet position with web
- 2 flame re-circulation chamber
- 3 simulated corner or edge feature of "I" beam

Figure 10 — General view of structural steelwork test specimen

Details of the construction of a structural steelwork specimen are given in Figure 11. For a structural steelwork test, the rear wall shall be constructed of 10 mm thick steel. The bottom flange may be omitted if desired. The web shall comprise two 10 mm thick steel plates, which are slotted before being welded together, to have thermocouples inserted and fixed in accordance with the methods given in Annex A. Holes shall be drilled in the rear wall of the flame re-circulation chamber to match the slot positions. Details of construction of the web are given in Figure 12. If the substrate material is not steel or the steel thickness of the web and rear wall is different from 20 mm and 10 mm respectively, the material and thickness used shall be stated in the test report.

When testing passive fire protection materials used to protect structural sections with substrates other than steel or when the thickness of the corner or edge feature on the structural section is different from 20 mm, the central web and rear wall of the flame re-circulation chamber may be constructed from the relevant substrate material and may be of the relevant thickness.

Dimensions in millimetres

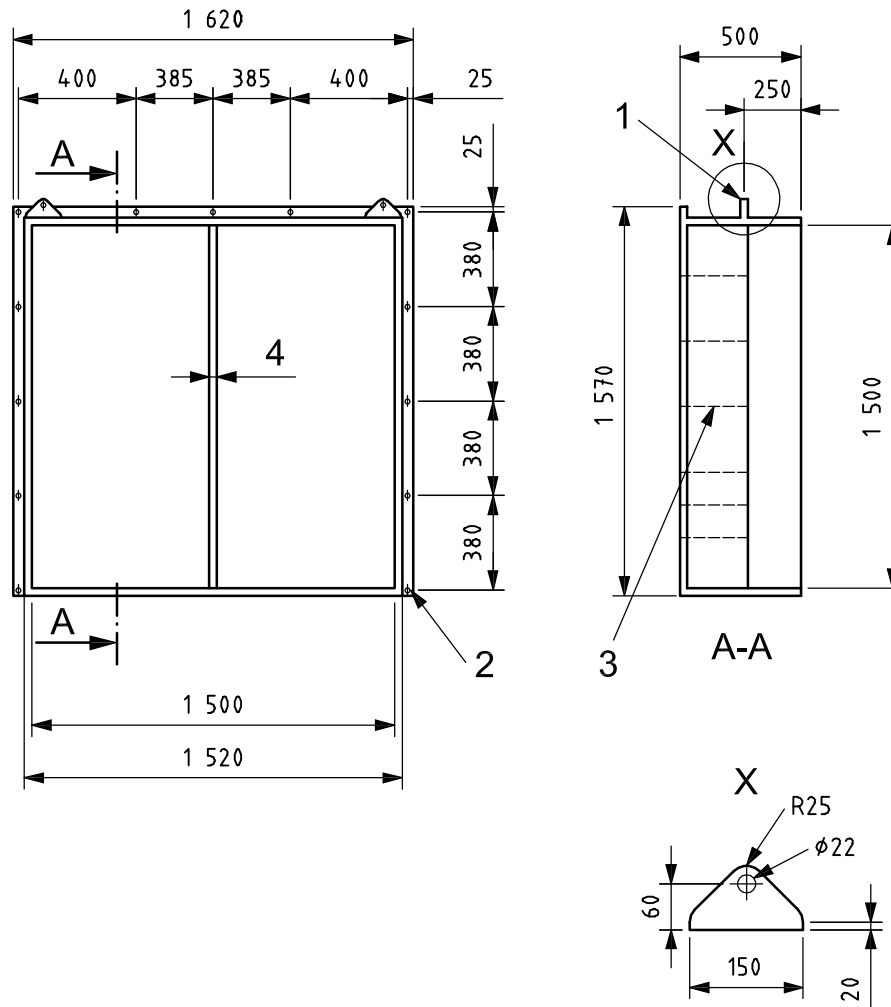

Key

- 1 lifting lug, 25 mm thick machined steel
- 2 thirteen holes drilled, $\varnothing 18$
- 3 six holes drilled and taped in bulkhead to match machined holes in central web; threads to be similar to 1/8 British Standard Pipe Thread
- 4 central web

Figure 11 — Construction of structural steelwork specimen

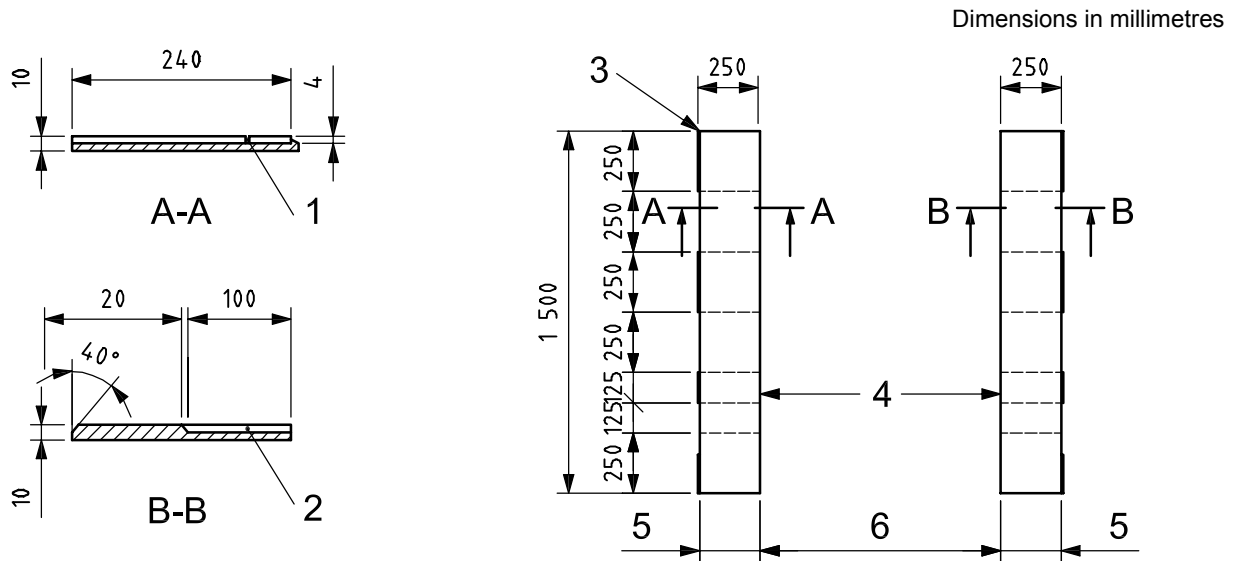

Key

- 1 groove machined 3,30 mm deep using 5,0 mm diameter ball nosed cutter
- 2 groove machined 3,0 mm deep using 5,0 mm diameter ball nosed cutter
- 3 weld preparation, four positions along this edge
- 4 weld preparation, full length along these edges
- 5 weld plates, together after machining with a single V-butt weld; weld to be intermittent and ground flush
- 6 weld plates, together after machining with a single continuous V-butt weld

Figure 12 — Construction of web for structural steelwork specimen

6.8 Tubular section test specimens (external configuration)

The tubular section test specimen shall consist of a 3 000 mm long tubular section and shall be of the following type depending on the outside diameter:

- a) if the outside diameter, including the passive fire protection system, does not exceed 350 mm the full-scale tubular section shall be used or
- b) if the outside diameter, including the passive fire protection system, exceeds 350 mm the diameter of the tubular section shall be reduced so that the outside diameter is no more than 350 mm, keeping the wall thickness of the tubular section as close as possible to that to be used in practice.

A general view of a tubular section specimen is given in Figure 13.

The material, diameter and wall thickness of the tubular section used shall be stated in the test report. The tubular section shall be drilled with holes of sufficient diameter to allow thermocouples to be passed down the inside of the tubular section. The access hole for each thermocouple shall be not more than 50 mm longitudinally from the measuring position.

In some cases, e.g. a pipe penetration specimen, the outside diameter may exceed 350 mm for a short length of the specimen.

Dimensions in millimetres

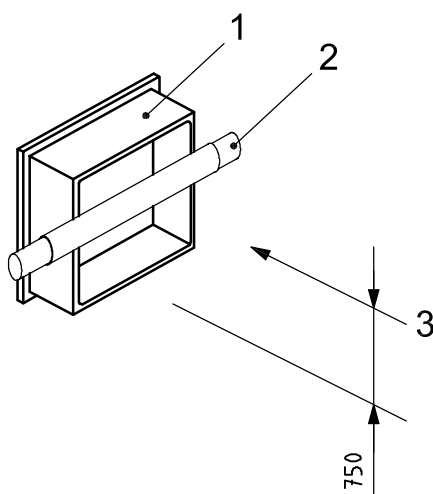
**Key**

- 1 flame re-circulation chamber
- 2 tubular section specimen
- 3 jet position

Figure 13 — General view of tubular test**6.9 Assembly test specimens****6.9.1 General**

Assemblies can be mounted on a panel (internal configuration) or a hollow section (external configuration). If an assembly is more than 400 mm in width or the geometry sufficiently complex that the flame characteristics are clearly affected, a demonstration at full scale may be necessary, e.g. a 3 kg s^{-1} natural gas jet fire impinging on a full scale specimen at 9 m from the release point.

6.9.2 Assemblies mounted on a panel

Assemblies to be mounted on a division (e.g. cable transit systems) should be mounted on to a panel specimen made from the type of division to be used in the intended application in accordance with 6.5. If the assembly cannot be tested full size without affecting the key features of the test, then a reduced scale assembly can be used provided it reproduces the key features of the intended application. The assembly shall be positioned no closer than 200 mm from exposed edges of the panel. Where more than one assembly are to be tested simultaneously in a panel, the separation between adjacent assemblies shall be 200 mm. If two assemblies are tested simultaneously, they shall be placed symmetrically about either side of the vertical centreline of the panel. The positioning of features that may affect the flow of the jet fire shall be at the discretion of the test laboratory and any third-party certifying body. The positions for a single panel mounted assembly and two panel mounted assemblies are given in Figure 14.

Dimensions in millimetres

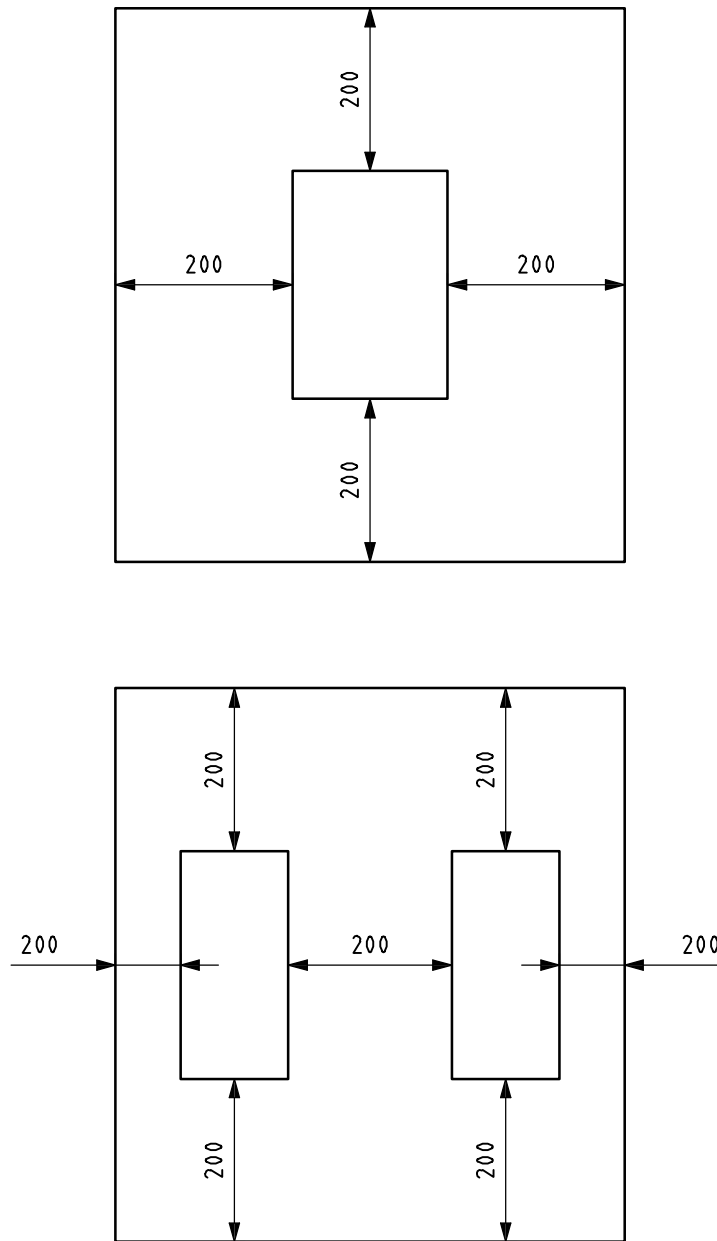
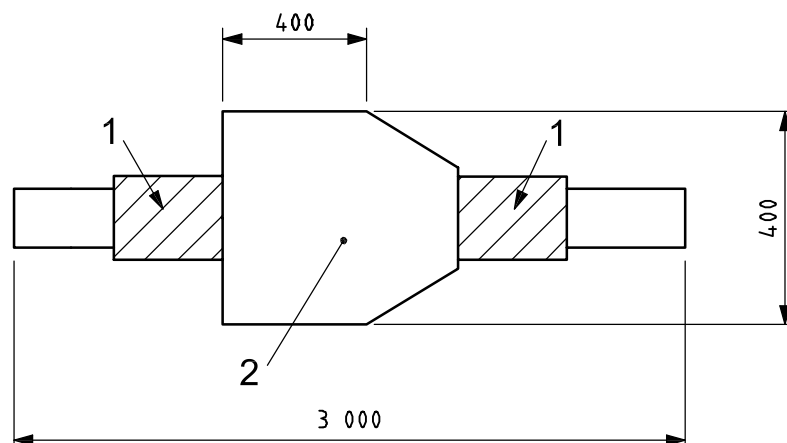

Figure 14 — Positions of panel mounted assemblies

6.9.3 Assemblies mounted on a tubular section

Assemblies to be mounted on a tubular section (e.g. removable jacket, pipe penetration seal) shall be mounted on a tubular section specimen in accordance with 6.7. For assemblies, such as soft jackets, which are applied uniformly, the maximum outer diameter (including the passive fire protection system) shall be a maximum of 350 mm. For asymmetric assemblies, such as valve protection boxes and pipe penetration seals, these shall normally be positioned in the centre of the tubular section. However, the positioning of features that may affect the flow of the jet fire shall be at the discretion of the test laboratory and any third-party certifying body. The maximum outside specimen diameter may be up to 400 mm provided that this is for less than a length of 400 mm. The position of an asymmetric tubular mounted assembly is illustrated in Figure 15.

Dimensions in millimetres

**Key**

- 1 passive fire protection material
- 2 pipe penetration seal (placed centrally)

Figure 15 — Position of tubular mounted assemblies (shown with a pipe penetration seal)

7 Passive fire protection materials

7.1 General

The passive fire protection materials and systems are either coated or mounted onto the substrates described in Clause 6.

7.2 Panel test specimens

When the passive fire protection material is in the form of a panel, the panel shall be fixed to act as the rear wall of the flame re-circulation chamber as shown in Figure 8. The method of mounting shown in Figure 16 depends on the type of passive fire protection and is detailed as follows.

- a) For a rigid stand-alone panel, at least one joint shall be included in the panel and this shall be positioned vertically, offset from the centre by 250 ± 50 mm. If the joint is not symmetrically resistant to a jet fire flowing across the front of the rear wall of the flame re-circulation chamber, e.g. a lap joint, the joint shall be oriented to give the most severe exposure to the jet fire as shown in Figure 16.

The rigid panel may extend to the full 1 620 mm × 1 620 mm substrate dimensions as discussed in 6.5.

- b) If the panel profile is not planar (e.g. trapezoidal), it may be necessary to incorporate a rigid surround around the panel to achieve a gas tight connection.
- c) When the passive fire protection material is in the form of a flexible panel, it may be necessary to incorporate a rigid surround (e.g. 50 mm box section steel) around the panel to achieve a gas tight connection as shown in Figure 16.
- d) When the passive fire protection is in the form of a coating, the joint is omitted as shown in Figure 16.

The connection between the panel and the flame re-circulation chamber shall be sealed to prevent passage of hot gases, for example, using soft mastic or ceramic fibre. In all cases, the side, top and bottom walls of the flame re-circulation chamber shall be protected by a ceramic board insulation material or other suitable passive fire protection material.

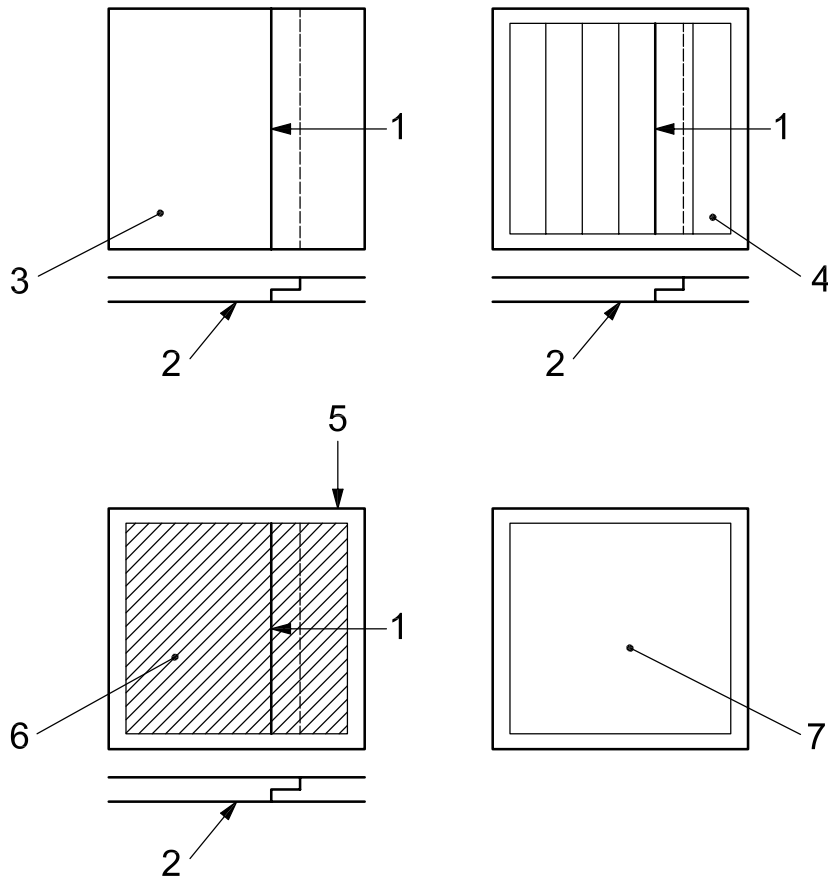

Key

- 1 joint
- 2 face exposed to jet fire
- 3 flat rigid panel
- 4 profile rigid panel
- 5 box section surround
- 6 passive fire protection covering
- 7 passive fire protection coating

Figure 16 — Different types of panel PFP

7.3 Structural steelwork test specimens

For testing passive fire protection materials applied as coatings, the structural steelwork test specimen shall have passive fire protection material applied directly to all inside surfaces of the specimen. The outside surfaces of the sides, top and bottom of the specimen shall also be coated to a distance of 50 mm from the front edge, including any reinforcement.

7.4 Tubular section test specimens

A minimum of 2 500 mm and a maximum of 2 700 mm of the central part of the tubular section test specimen shall be covered by the passive fire protection material under test. The unprotected ends of the tubular section shall be protected by a suitable insulation material. The flame re-circulation chamber shall be protected by a ceramic board insulation material or other suitable passive fire protection material.

7.5 Assembly specimens

7.5.1 General

Penetration systems may be tested as either a panel (internal configuration) or tubular mounted (external configuration) assembly. The configuration chosen shall be the most severe for the type of seal to be tested and shall be at the discretion of the test laboratory and any third-party certifying body.

7.5.2 General requirements for assemblies mounted on panels — Cable transit systems

For assemblies mounted on panels, the panel shall be fixed to act as the rear wall of the flame re-circulation chamber as shown in Figure 8. The connection between the panel and the box shall be sealed to prevent passage of hot gases, for example, using soft mastic or ceramic fibre. The side, top and bottom walls of the flame re-circulation chamber shall be protected by a ceramic board insulation material or other suitable passive fire protection material.

A cable transit consists of a metal frame, box or coaming, sealant system or material and the cables, and it may be uninsulated, partially insulated or fully insulated. The metal frame, box or coaming shall be mounted into a panel representative of the actual bulkhead using the normal method. For example, the frame, box, or coaming, which supports the cable transit system, may be incorporated into a bulkhead (typically 830 mm × 740 mm). The frame, box or coaming should be fitted such that it is flush with the front surface of the bulkhead. The bulkhead is then welded into a hole cut into a support panel, e.g a firewall. This forms the back panel of the flame re-circulation chamber. The transit(s) shall be tested incorporating a range of different types of cable (e.g. in terms of number and type of conductor, type of sheathing, type of insulation material or size) and should provide an assembly which represents a practical situation. No more than 40 % of the inside cross-sectional area of each transit shall be occupied by cables and the distances between the cables and the inside of the transit shall be the minimum which is allowable for the actual penetration sealing system. The cables shall project no more than 250 mm beyond the panel on the exposed side of the panel and 500 mm on the unexposed side. The test results obtained from a given configuration are generally valid for cables of size equal to or smaller than those tested. A general view of a cable transit system in position is illustrated in Figure 17.

NOTE Details of the arrangements for panel mounted pipe penetration systems will be given in a future part of ISO 22899.

Dimensions in millimetres

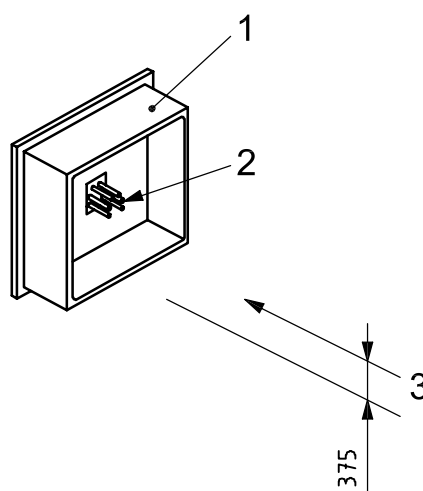

Key

- 1 flame re-circulation chamber
- 2 cable transit system
- 3 jet position

Figure 17 — General view of cable transit system

7.5.3 General requirements for assemblies mounted on tubular sections

For assemblies fixed to a tubular section, see Figure 15.

- a) If the assembly (e.g. soft jacket) is intended to protect a tubular section or vessel, a minimum of 2 500 mm and a maximum of 2 700 mm of the central part of the tubular section test specimen shall be covered by the assembly under test.
- b) If the assembly is a removable jacket, the fixing method shall be representative of the intended use and joints/fitments shall be oriented to give the most severe exposure to the jet fire.
- c) If the assembly is a pipe penetration seal, a representative seal shall be mounted on the tubular section specimen.

7.5.4 Pipe penetration systems

Penetrations shall be mounted on to a tubular section specimen in accordance with 6.8. A typical arrangement is as follows:

- a) a 3 000 mm long, approximately 215 mm outside diameter steel tubular section with a wall thickness of approximately 6 mm is used as the basic substrate for the specimen;
- b) a second approximately 550 mm long, approximately 305 mm outside diameter 10 mm thick tubular section is then sleeved over the narrower diameter section and welded into position by means of two perforated end plates;
- c) the seal is then attached between the two different diameter pipes;
- d) the surface of the substrate which is not protected by the seal should be coated with the passive fire protection to be used in practise; this passive fire protection should extend to within 150 mm of each end of the basic substrate;
- e) the 150 mm at each end of the pipe which is unprotected shall be wrapped in a suitable insulating material to prevent any heat transfer from the ends of the substrate to the seal.

A typical arrangement for fitting the seal in shown in Figure 18 and a general view of the a penetration seal mounted on a tubular section in position is given in Figure 19.

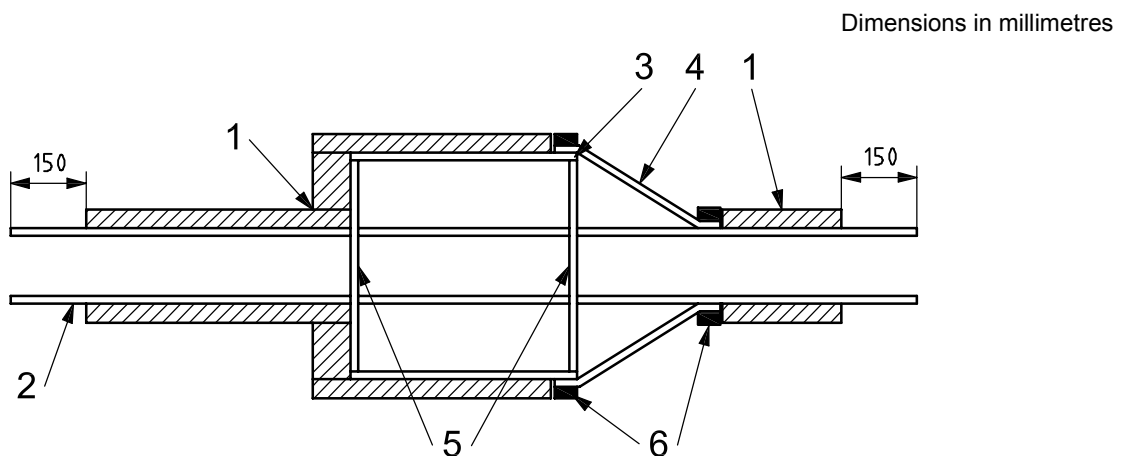

Key

1	passive fire protection	4	seal
2	small outside diameter pipe	5	perforated plates
3	large outside diameter pipe	6	fastenings

Figure 18 — Typical arrangement for fitting a pipe penetration seal to tubular sections

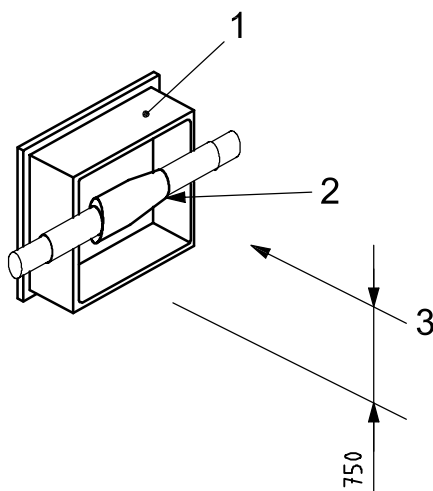

Key

- 1 flame re-circulation chamber
- 2 pipe penetration seal mounted on tubular section
- 3 jet position

Figure 19 — General view of external configuration of a pipe penetration test

8 Instrumentation

8.1 General

Thermocouples shall be fastened to all test specimens. The type and fixing shall be in accordance with one of the methods described in Annex A. For tests requiring use of a protective chamber, the air temperature shall be measured inside the protective chamber $500 \text{ mm} \pm 25 \text{ mm}$ from the back of the rear wall of the flame re-circulation chamber, in the centre, and $250 \text{ mm} \pm 25 \text{ mm}$ from the top.

Readings shall be recorded at intervals of not more than 30 s.

8.2 Panel test specimens

Thermocouples shall be fastened to the back of the rear wall in positions as shown in Figure 21 in accordance with one of the methods described in Annex A. Additional thermocouples may be fastened to the rear of the joint at the discretion of the testing laboratory and any third-party certifying body.

8.3 Structural steelwork test specimens

Thermocouples shall be fastened to the back of the rear wall in positions shown in Figure 20 in accordance with one of the methods described in Annex A. Sheathed thermocouples shall be inserted into the central web as shown in Figure 21 and in accordance with the method described in Annex A.

Dimensions in millimetres

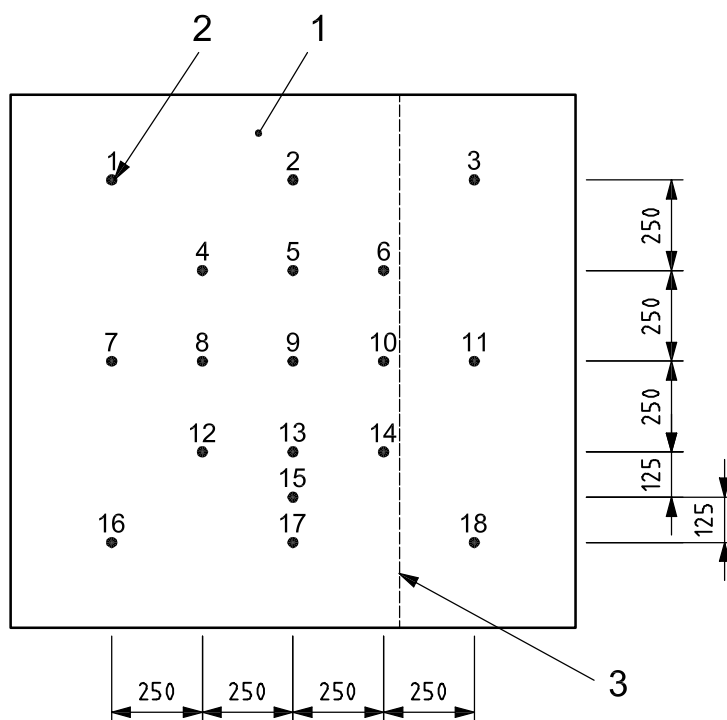

Key

- 1 view from rear of specimen
- 2 thermocouple location
- 3 joint

Figure 20 — Thermocouple positions for panel test specimen

.....

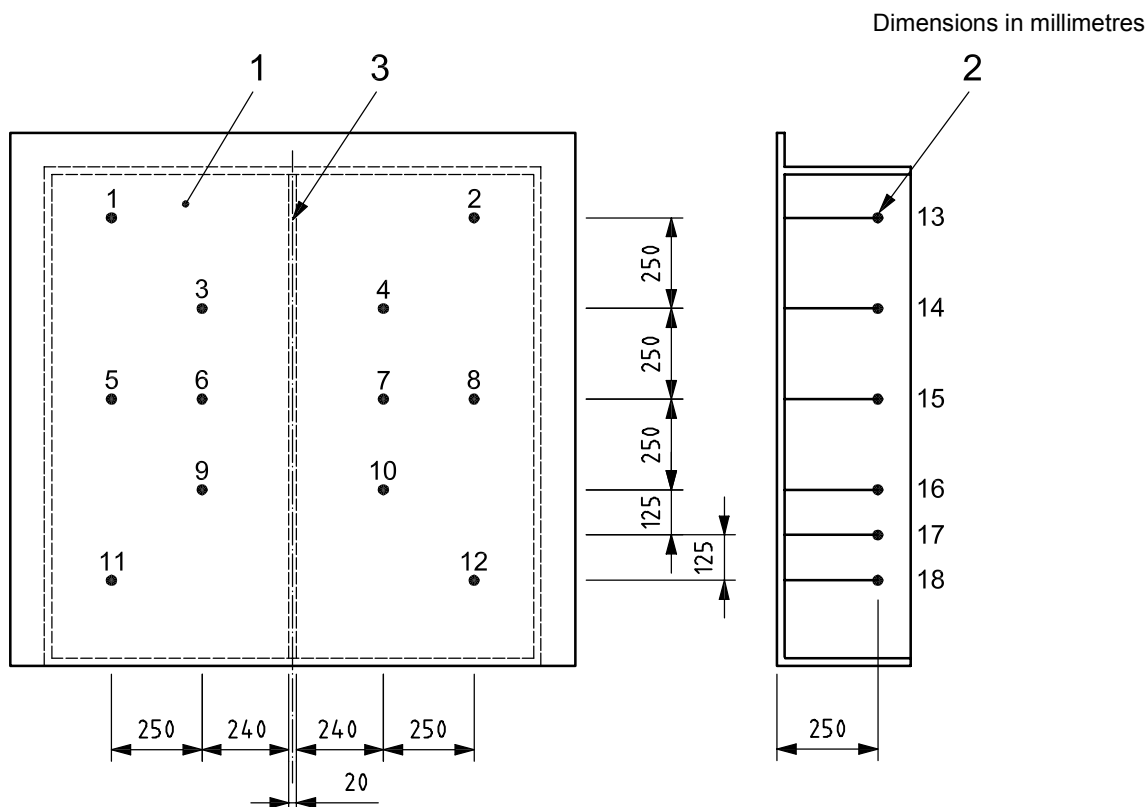

Key

- 1 view from rear of specimen
- 2 thermocouple location
- 3 simulated corner or edge feature of "I" beam

Figure 21 — Thermocouple positions for structural steelwork test specimen

8.4 Tubular section test specimens

Thermocouples shall be fastened to the test specimen at the positions shown in Figure 22, in accordance with one of the methods described in Annex A.

The thermocouples shall be run longitudinally on the outside for no more than 50 mm before being passed through holes to the inside of the tubular section.

NOTE 1 If the substrate diameter is less than 100 mm, a reduced number of thermocouples can be used at each circumference.

NOTE 2 For removable systems, where the thermocouples do not interfere with the fixing of the system to the substrate, the thermocouples can be run longitudinally along the outside of the tubular specimen.

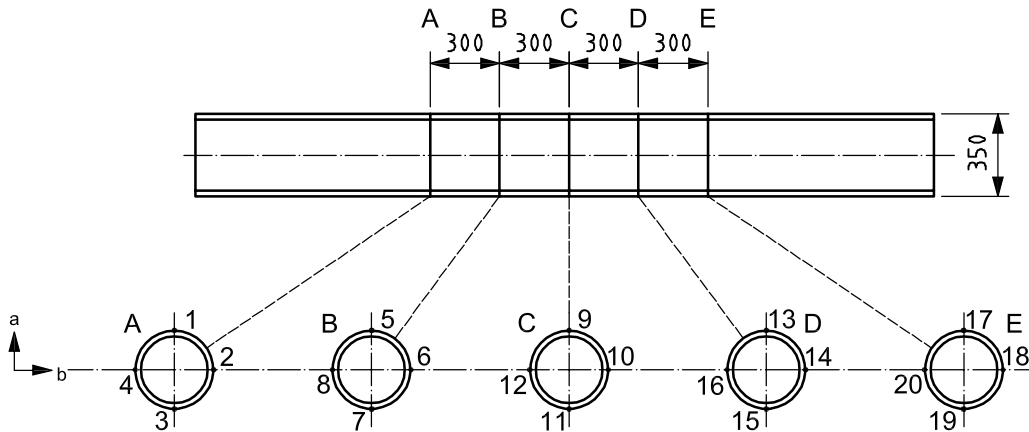

- a Thermocouple location on top of tubular section.
- b Thermocouple location facing towards jet fire.

Figure 22 — Thermocouple positions for tubular section test specimen

8.5 Assembly specimens

8.5.1 General

For panel mounted assemblies, thermocouples shall be fastened to the back of the rear wall in positions shown in Figure 20 in accordance with one of the methods described in Annex A. Where necessary, additional thermocouples shall be fastened to, and inside, the assembly to ensure that the key features of the assembly can be assessed. These thermocouple positions are at the discretion of the testing laboratory and any third-party certifying body.

8.5.2 Panel mounted cable transit systems

For uninsulated cable transit systems, thermocouples shall be fixed on the unexposed face at each of the locations shown in Figure 23.

- a) At two positions on the surface of the outer perimeter of the frame, box or coaming at a distance of 25 mm from the unexposed surface of the panel. One thermocouple shall be fixed on the top and bottom faces opposite to each other.
- b) At two positions at the end of the transit, on the face of the sealant system or material at a distance of 25 mm from a cable;
- c) On the surface of each type of cable included in the cable transit, at a distance of 25 mm from the face of the sealant system of material. In case of group or bunch of cables the group shall be treated as a single cable. The thermocouples should be mounted on the uppermost surface of the cables.

For each partially insulated or fully insulated cable transit, thermocouples shall be fixed on the unexposed face at equivalent positions to those specified for an uninsulated transit as illustrated in Figure 22.

Additional thermocouples may be fixed dependent upon the complexity of the cable transit system.

Dimensions in millimetres

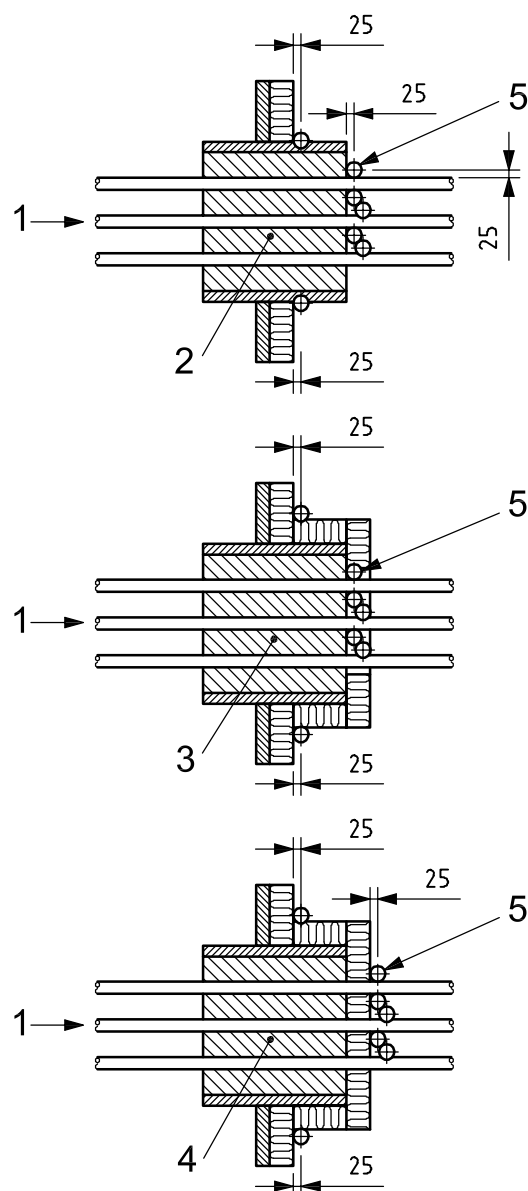
**Key**

- 1 jet fire
- 2 uninsulated transit
- 3 partially insulated transit
- 4 fully insulated transit
- a Thermocouple location.

Figure 23 — Thermocouple positions for cable transit systems

For tubular section mounted assemblies, thermocouples shall be fastened to the test specimen in accordance with one of the methods described in Annex A. The thermocouples shall be fastened to the tubular section and to, and inside, the assembly to ensure that the key features of the assembly can be assessed. The thermocouple positions will be at the discretion of the testing laboratory and any third-party certifying body.

NOTE Details of the instrumentation of panel mounted pipe penetration systems will be given in a future part of ISO 22899.

8.5.3 Tubular section mounted pipe penetration systems

For tubular mounted penetrations, the thermocouples shall be fastened to the tubular section and to, and inside, the assembly to ensure that the key features of the assembly can be assessed. Typical positions are illustrated in Figure 24.

Dimensions in millimetres

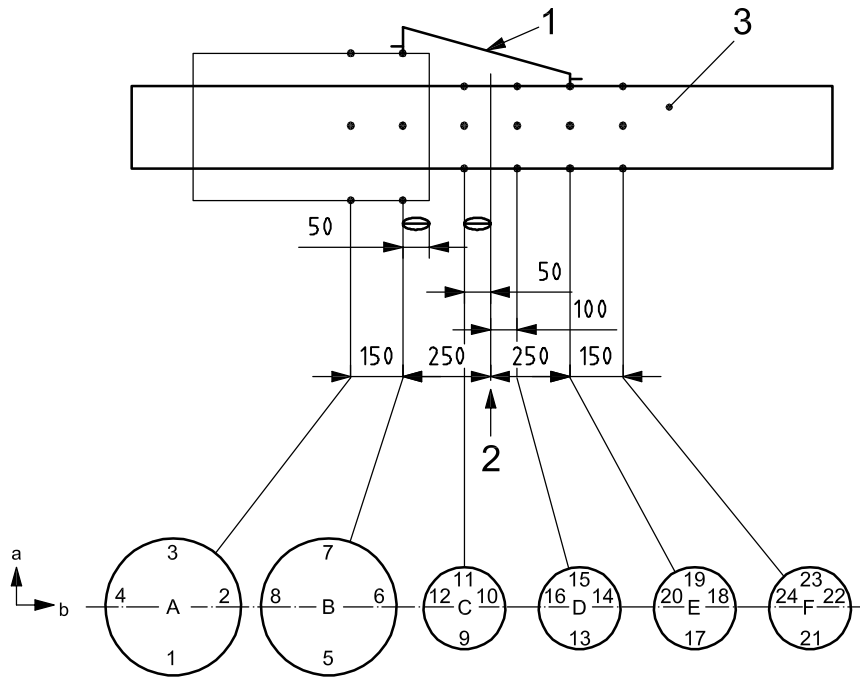

Key

- 1 pipe penetration seal
- 2 jet fire
- 3 tubular section
- a Thermocouple location on tubular section facing towards jet fire.
- b Thermocouple location on upper surface of tubular section.

Figure 24 — Typical thermocouple positions for tubular mounted penetrations

9 Test apparatus and conditions

9.1 Nozzle geometry and position

9.1.1 General

Details of construction of the tapered, converging nozzle from which the propane vapour is issued, are given in Clause 6. It is advisable to protect the nozzle and closest part of the fuel line from the flames.

9.1.2 Nozzle position for panel (including panel assemblies) and steelwork tests

The nozzle shall be aimed horizontally and normal to the rear wall of the test specimen. The tip of the nozzle shall be located 1 000 mm ± 50 mm from the front surface of the passive fire protection material covering the rear wall of the test specimen. Its centre shall be 375 mm above the inner surface of the test specimen's base excluding the passive fire protection material as shown in Figure 25. For assemblies where a feature may not be flush with the panel, the tip of the nozzle will be located at a distance and angle agreed between the test laboratory and any third-party certifying body.

Dimensions in millimetres

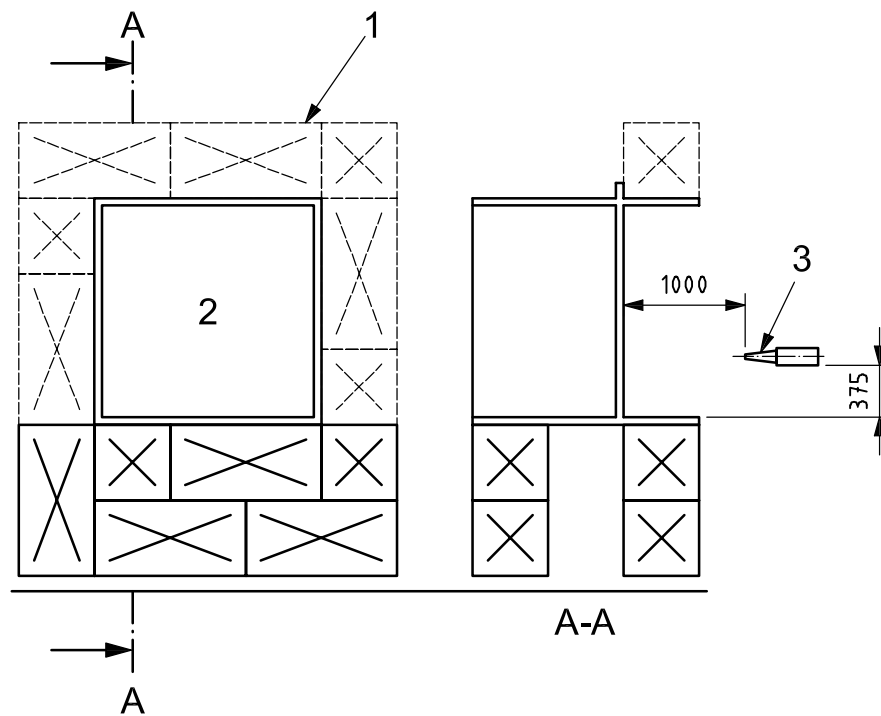
**Key**

- 1 lightweight insulation blocks
- 2 test specimen
- 3 jet nozzle

Figure 25 — Layout of test facility with panel or steelwork test specimen

9.1.3 Nozzle position for tubular section (including assemblies) tests

The nozzle shall be aimed horizontally and normal to the rear wall of the flame re-circulation chamber and to intersect the centre of the tubular section test specimen. The test specimen shall be supported horizontally at mid-height across the front of the flame re-circulation chamber, and touching it. The tip of the nozzle shall be located $1\,000\text{ mm} \pm 50\text{ mm}$ away from the front surface of the passive fire protection material covering the test specimen as shown in Figure 26.

www.iso.org

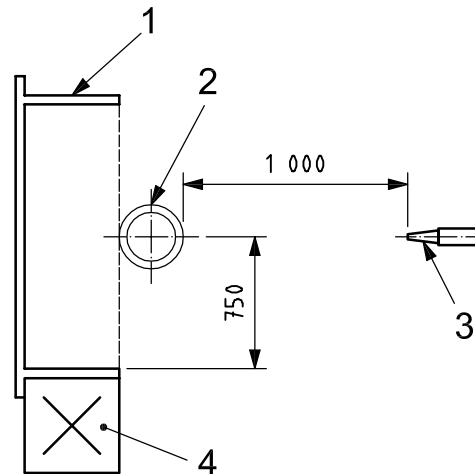

Key

- 1 flame re-circulation chamber
- 2 tubular section
- 3 jet nozzle
- 4 lightweight insulation block

Figure 26 — Layout of test facility with tubular section test specimen

9.2 Fuel

The fuel shall be commercial propane, delivered as vapour without a liquid fraction at a steady rate of $0,30 \pm 0,05 \text{ kg s}^{-1}$. There shall be a means of monitoring the mass flow rate during the test. The total amount (in kilograms) of propane used shall be recorded; for the test to be valid, this shall be $0,3 \times \text{duration of test (in seconds)} \pm 5 \%$. The equipment and method of calculation shall be reported.

9.3 Test environment

The test shall be carried out in an environment in which the effects of the weather do not significantly affect the test. The specimen shall be shielded from the effects of high wind such that the wind speed in the immediate vicinity of the specimen is less than 3 m s^{-1} . The test may be performed if it is raining provided that the prevailing wind does not blow rain directly into the flame re-circulation chamber. The average substrate temperature prior to testing shall be between $-10 \text{ }^\circ\text{C}$ and $+40 \text{ }^\circ\text{C}$.

10 Test procedure

- a) The sponsor shall specify the duration of the test. It may be varied during the test according to how the specimen performs.
- b) The sponsor shall provide the specimen for the test in a condition representative of its practical application.
- c) For panel or steelwork tests, fix the test specimen to the protective chamber and mount the assembly on a suitable support frame approximately 1,0 m from the ground as shown in Figure 25. The bottom, sides and top of the specimen shall be protected from thermal radiation by fire resistant blocks or boards.

NOTE It is usually necessary to protect the specimen-supporting frame from flames.

- d) If a tubular section test is carried out, position the test specimen in front of the flame re-circulation chamber (see Figure 26). The support stands and the bare ends of the tubular section shall be protected by thermal insulation.
- e) Photographs shall be taken of the test specimen before the test.
- f) If the passive fire protection is a coating material, measure the thickness at the positions specified in Figures 27, 28 and 29 for panel, steelwork and tubular section test specimens, respectively.

The measurement positions indicated should be regarded as approximate. If there are clear signs of thinning or thickening at positions away from those indicated for measurement, additional measurements should be taken. The thickness may be measured by drilling a 1,5 mm hole through the passive fire protection material and then using a depth gauge. Care should be taken to ensure that any reinforcing mesh does not lead to a false reading. If the performance of the material may be affected by drilling holes, alternative methods, such as ultrasonic depth gauges, may be used provided they are described in the report and the method of calibration stated.

- g) For thermo-setting (e.g. intumescent) materials, hardness measurements (e.g. Shore D) shall be made at a minimum of three positions, selected at the discretion of the test laboratory.
- h) Environmental conditions shall be measured immediately before the test and any significant changes during the test noted. Measurements taken shall include ambient temperature and, for tests conducted outdoors, wind speed and direction, and whether there is any precipitation.
- i) Ensure that a steady flow rate of propane vapour is provided. When the jet fire first impinges on the specimen, a timer shall be started and the flow rate, temperatures and pressures monitored. Readings of the instruments shall be taken at least once every 30 s. The test shall continue until either the time or temperature selected prior to the test is reached.

Dimensions in millimetres

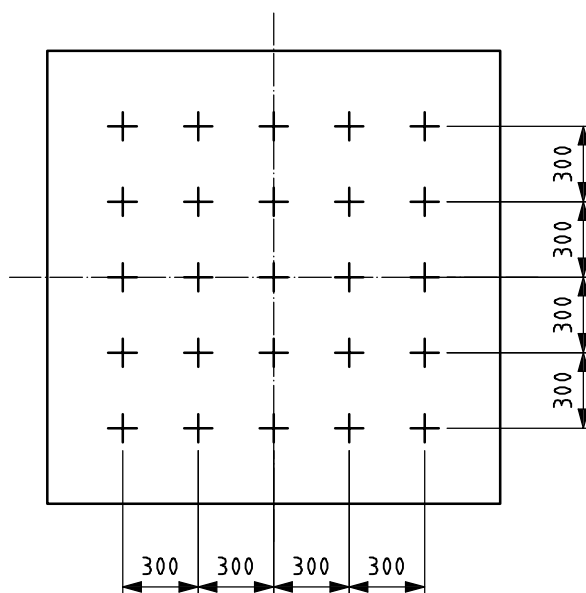
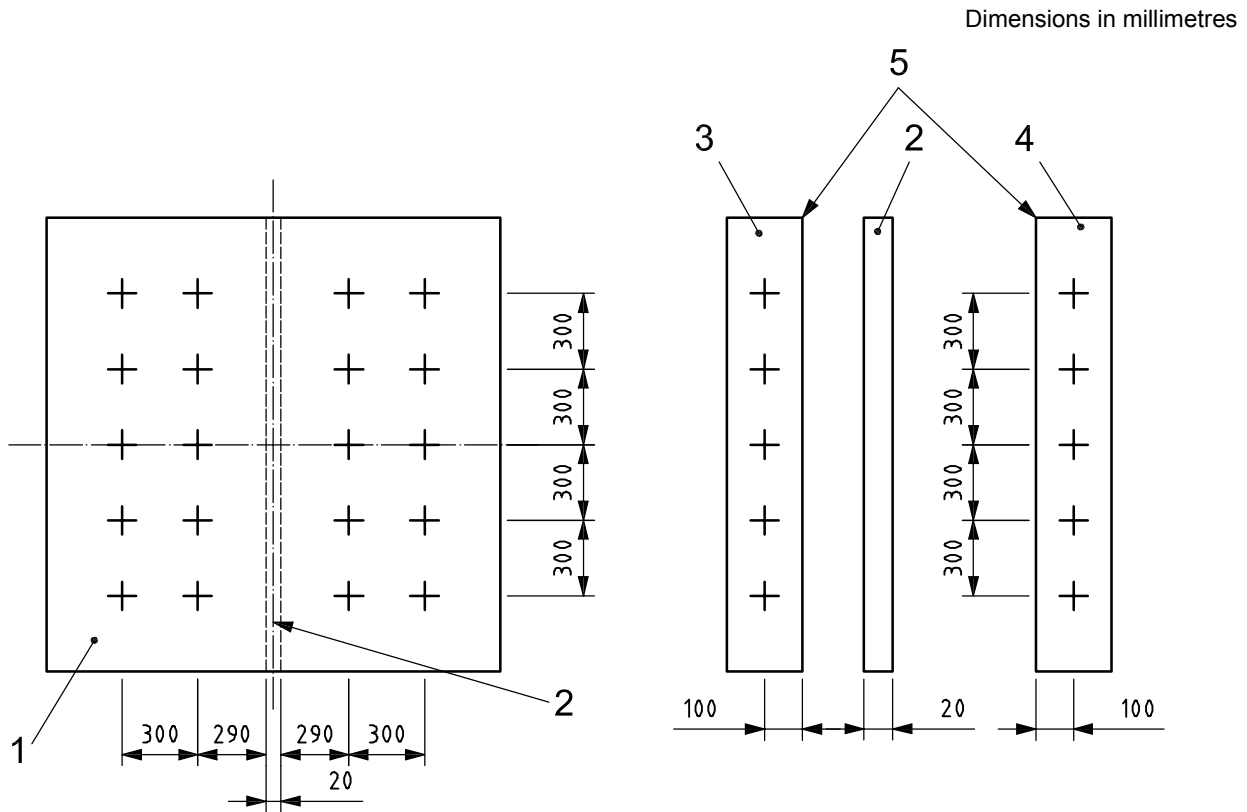

Figure 27 — Passive fire protection thickness measurement locations for panel tests



Key

- 1 view of coated steel plate from front of flame re-circulation chamber
- 2 simulated corner or edge features of "I" beams
- 3 left side of simulated corner or edge features of "I" beams
- 4 right side of simulated corner or edge features of "I" beams
- 5 front edges

Figure 28 — Passive fire protection material thickness measurement locations for steelwork

- j) Observations shall be recorded of significant details of the behaviour and appearance of the test specimen during the test and after the jet fire is extinguished. Information on deformation, spalling, cracking or burning of the passive fire protection material and continuance of flaming shall be noted.
- k) Photographs of the test specimen shall be taken as soon as is practicable after the jet fire has been extinguished and also approximately 1 h after the jet fire is extinguished. These shall be included in the test report.
- l) Continuous visual records shall be made of the test.

Dimensions in millimetres

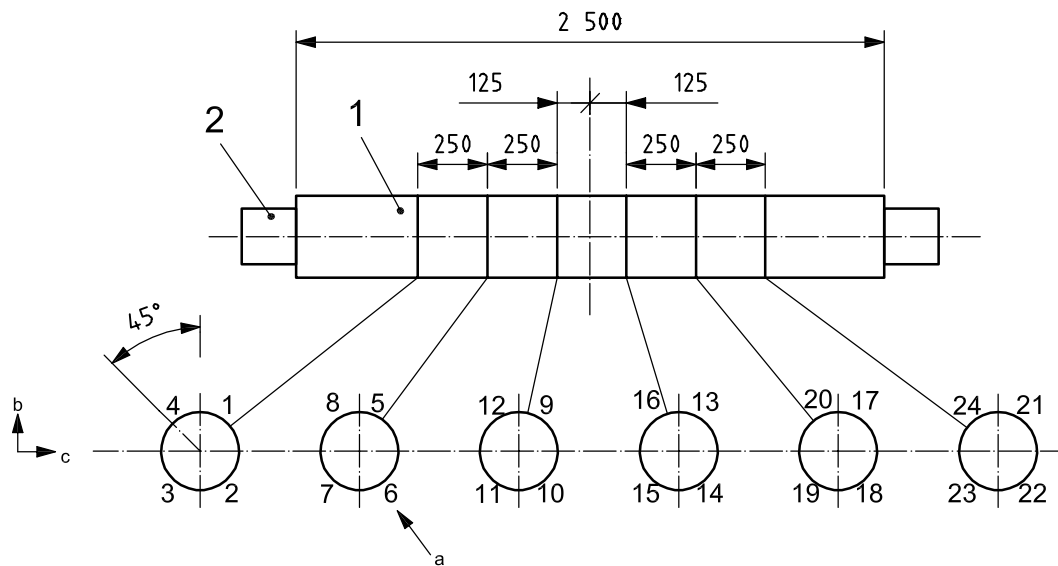
**Key**

- 1 passive fire protection
- 2 tubular section
- a Location of thickness measurement.
- b Top of tubular specimen.
- c Face of tubular specimen towards jet fire.

Figure 29 — Passive fire protection material thickness measurement locations for tubular section tests

11 Repeatability and reproducibility

For information on reproducibility (between-laboratory variability), see Bibliography [4].

No direct data on repeatability (within-laboratory variability) are currently available. However, the reproducibility data suggest that the repeatability is acceptable.

12 Uncertainty of measurement

There are many factors that may affect the result of a fire resistance test. The key factors requiring close control are the fuel flow rate and the distance and aiming of the jet release nozzle. Those concerned with the variability of the specimen including its materials, manufacture and installation are not related to the uncertainty of measurement.

The combined (thermocouples + transmitters + logging system) error of the temperature measurement systems are of the order of ± 3.5 °C. Hence a tolerance of 5 °C is allowed when measuring a temperature rise.

13 Test report

The test report shall include the following information:

- a) name of the testing laboratory, test date, unique test reference and report identification;
- b) names of the sponsor/customer, the manufacturer and the product;
- c) documentation on how and when the test specimen was prepared, details of the application of the PFP material, the name of the applicator company and, if appropriate, the name of the third-party inspection organisation;
- d) complete description of the test specimen, including measurements of the thickness of passive fire protection material and the hardness, if measured; the mean, standard deviation and range of measurements of thickness should be given as well as details of any joint (if applicable) e.g., position, type, size of overlap and method of fixing;
- e) construction drawings of passive fire protection system wherever possible;
- f) when appropriate, details of any deviations from the normal test configurations and the reasons for them;
- g) record of test details and post fire characterization including:
 - 1) ambient conditions;
 - 2) fuel pressure and temperature at least every 30 s throughout the test, where these are used to calculate mass flow rate, and the method of control and calculation;
 - 3) fuel mass flow rate at least every 30 s throughout the test and total mass of fuel used;
 - 4) for reacting materials, the thickness of unreacted or partially reacted material left at the end of the test and the char thickness at the positions where the initial thickness was measured; the condition of the char and the strength of bonding to the underlying material shall be recorded;
 - 5) for materials retained/supported by a reinforcing mesh, the condition of the mesh at the end of the test;
 - 6) for assemblies, a full inspection following the test to validate construction details and assess fire performance (the assembly should be dismantled so that all components of the system can be checked for flame penetration, integrity and general condition and a visual record made);
- h) the test result, in the format given below:
 - 1) the behaviour and appearance of the test specimen during and after the test and photographs;
 - 2) temperature/time graphs and spreadsheets of temperatures at no more than 30 s intervals for each thermocouple;
 - 3) a table showing the minimum time (rounded down to the nearest minute) for the temperature rise (in 25 °C steps for temperatures below 200 °C and in 50 °C steps for temperatures above 200 °C) above the initial temperature and identification of the thermocouple used to measure it;
 - 4) an optional classification in terms of the type of specimen tested, critical temperature rise and period of resistance in accordance with Clause 15.

For an example report format, see Annex B.

NOTE Additional information on classification will be given in a future part of ISO 22899.

14 Practical application of test results

14.1 General

As indicated in the Introduction, this test is considered to be complementary to the hydrocarbon fire resistance test (see ISO 834-3).

NOTE Information on factors to be considered will be given in a future part of ISO 22899.

14.2 Performance criteria

14.2.1 General

It is not the purpose of this test method to provide guidance on the acceptability of a particular thickness of passive fire protection coating or method of assembly. The acceptance process must be left to the appropriate authority, whether regulatory or advisory, which will take into consideration the proposed usage and safety requirements. Although the method specified has been designed to simulate some of the conditions that occur in an actual jet fire, it cannot reproduce them all exactly. The results of this test do not guarantee safety but may be used as elements of a fire risk assessment for structures or plant. This should also take into account all the other factors that are pertinent to an assessment of the fire hazard for a particular end use.

The criterion of performance, provided by the test, is the minimum time required to reach the critical temperature associated with the fire scenario to be protected against. However, the following factors shall also be considered when assessing performance.

14.2.2 Coatings and spray-applied materials

14.2.2.1 Substrate temperature

The temperature time profiles at each measurement position shall be used to determine the maximum temperature at each position reached during the test. As the jet fire is not applied uniformly over the specimen, the mean substrate temperature shall not be used in the evaluation. The position and time of a sudden increase in the rate of temperature rise, if any, should be recorded as it is indicative of possible failure of the passive fire protection coating at that point. For the same reasons, the localized maximum temperature shall be reported in conjunction with the nearest passive fire protection thickness measurement.

14.2.2.2 Reacted/unreacted material remaining and condition of the reinforcement (if present)

The amount of unreacted/partially reacted material remaining and the amount and condition of the reacted material (char for epoxy intumescent or subliming materials) provides an indication of performance. Particularly for the protection of any edge features, the condition of any reinforcement is important. The condition of the reacted material and the amount of unreacted/partially reacted material may be evaluated in terms of:

- a) bare metal exposed and reinforcement destroyed;
- b) no bare metal exposed but the reinforcement in poor condition and the reacted material easily detachable;
- c) reacted material firmly attached and the majority of the reinforcement intact and attached;
- d) unreacted/partially reacted material present, reacted material and reinforcement firmly attached.

If the temperature criterion is met, then a specimen meeting criterion d) clearly provides a wider safety margin than a specimen meeting criterion a). A statement of the criterion that is most appropriate should be included in the report.

NOTE Cementitious materials lose retained water during the test and then act as passive insulators. The external appearance and material thickness may not change significantly. However, whilst water is present, the temperature of the substrate remains at 100 °C and, when all the water has been driven off, the temperature increases to above 100 °C. Examination of the temperature-time curves provides an indication of whether there is retained water (unreacted or partially reacted material) at the end of the test.

14.2.3 Systems and assemblies

14.2.3.1 Substrate temperature

The temperature time profiles at each measurement position shall be used to determine the maximum temperature at each position reached during the test. As the jet fire is not applied uniformly over the specimen, the mean substrate temperature shall not be used in the evaluation. The position and time of any sudden increase in the rate of temperature rise, if any, should be recorded as it is indicative of possible failure of the system/assembly at that point.

14.2.3.2 Loss of integrity

The penetration of flames or hot gases through any cracks, holes or breaches in joints should be considered when assessing the integrity of a system. Particularly for flexible systems (e.g. blankets and jackets), the condition of the method of fixing (straps, etc.) is also important. The amount of penetration and condition of the method of fixing may be evaluated in terms of the:

- a) evidence of passage of flames through the system with the fixing system ineffective;
- b) evidence of passage of hot gases/smoke through the system with the fixing system effective;
- c) no passage of hot gases through the system and with the fixing system effective.

If the temperature criterion is met, then a specimen meeting criterion c) clearly provides a wider safety margin than a specimen meeting criterion a). A statement of the criterion that is most appropriate should be included in the report.

14.3 Factors affecting the validity of the test

14.3.1 General

It is inevitable that, during some tests, there is a failure of control, instrumentation or of a seal. The most common failures are considered as follows.

14.3.2 Interruption of the jet fire

This may be done deliberately to allow examination of the specimen at an intermediate stage or through failure of the fuel supply. The main effect of an interruption is the application of an additional thermal shock to the specimen resulting in a more severe test. The test may still be considered valid provided that, whilst the jet fire is applied to the specimen, the mass flow rate is within the limits set out in 9.2 and the duration of the interruption and effect of the additional thermal shock on the specimen are assessed and recorded.

14.3.3 Failure of thermocouples

Up to three thermocouples may fail during a test and the test still be considered valid provided that the thermocouple position(s) do not correspond to the area of greatest damage.

14.3.4 Failure of a seal

A gas-tight seal should be maintained between a panel and the flame re-circulation chamber. If the seal loses integrity, flames may break through resulting in external heating of the environmental protection chamber affecting the heat loss characteristics of the rear of the panel. The severity of the breakthrough and its effect on the measured temperatures should be assessed. The test may still be considered valid but the maximum temperature rise measured on the panel and the time taken to reach it should not be adjusted.

15 Classification (optional)

15.1 General

The classification is related to the type of application and based on the maximum temperature rise above the initial temperature observed during the test and the period of exposure to the jet fire. The procedure used is based on that proposed in ISO 13702. The classification rating is specified as:

Type of fire/Type of application/Critical temperature rise (degrees centigrade)/Period of resistance (minutes)

15.2 Type of fire

ISO 13702 distinguishes between cellulosic fires (CF), hydrocarbon pool fires (HC) and jet fires (JF). As suggested in ISO 13702, the letters JF shall represent the type of fire used in this test. The other designations are mentioned as it is likely that some fire scenarios may be specified in the form of a jet fire followed by a hydrocarbon pool fire.

NOTE The application of multiple fire scenarios will appear in a future part of ISO 22899.

15.3 Type of application

The specimen tested will depend on the practical application being considered. The most common types of application are:

- structural steel;
- pressure vessels;
- pipes;
- fire barriers;
- cable transit systems;
- pipe penetration seals.

Where the test is used for another type of application, e.g. control panel, emergency shut down valve, inspection hatch, this shall be specified.

15.4 Critical temperature rise

The critical temperature rise is defined, in advance of the test, according to the protection criteria for the equipment, assembly or structure being protected. For example, 140 °C is used (ISO 834-3) for fire barriers and 400 °C is used (ISO 13702) for load-bearing steel structures. The corresponding value for load-bearing aluminium structures is 200 °C.

The maximum temperature rise is the highest temperature rise observed at any location during the test. The critical temperature rise criterion is met if the maximum temperature rise observed is no more than 5 °C higher than the critical temperature rise. The 5 °C tolerance is to allow for a measurement error.

15.5 Period of resistance

The period of resistance is the total time that the specimen is exposed to the jet fire. This is the overall test duration less any time that the jet is interrupted as described in 14.2.2. The period of resistance shall be rounded down to the nearest 5 min. The most common periods of resistance are 15 min, 30 min, 60 min, 90 min and 120 min.

15.6 Example of application of the rating

Two examples are given of the application of the classification procedure to the protection of structural steel (critical temperature rise 400 °C).

Case 1 The maximum temperature rise observed after a jet fire exposure duration of 60 min is 390 °C. The critical temperature rise is not exceeded in 60 min and hence the rating is:

JF/Structural steel/400/60.

Case 2 The maximum temperature rise observed after a jet fire exposure duration of 56 min is 400 °C and hence the rating is:

JF/Structural steel/400/55.

Further information on critical temperature rises is given in ISO 13702.

NOTE Additional information on classification methods will be given in a future part of ISO 22899.

Annex A (normative)

Methods of fixing thermocouples

A.1 General

Chromel/alumel (type K) thermocouples, with conductors of a diameter appropriate to the method of fixing shall be used. Thermocouples shall be attached in accordance with one of the methods given in A.2 to A.6.

A.2 “Quick Tip” attachment

Place the two 0,3 mm diameter thermocouple wires into a metal piece with pre-drilled holes for the wires. Squeeze the metal piece in a special tool into a cylindrical shape, 1,5 mm long and 1,5 mm in diameter, firmly gripping both wires in the process. Drill a 2 mm hole, 2 mm deep, in the position where the thermocouple is to be fixed. Place the joint piece in the hole and use a drift to peen over the metal.

A.3 Capacitive discharge welding

Equipment, suitable for attaching thermocouples to a metal substrate, shall be used. Follow the manufacturer's instructions in preparing the surface and attaching the thermocouple.

NOTE Small pieces of stainless steel shim may be spot welded over the thermocouple to add mechanical strength and prevent stress being placed on the junction.

A.4 Drilling and peening

This method shall be used for attaching sheathed or welded junction thermocouples to a metal substrate. If the thermocouple has separate wires, weld them together. Drill a hole of appropriate diameter in the position in which the thermocouple is to be attached. Insert the thermocouple and peen over the edges of the hole with a centre punch.

A.5 Adhesive

This method shall be used for fixing thermocouples to non-metal substrates. If the thermocouple has separate wires, weld them together. Fix the thermocouple to the substrate with an epoxy adhesive suitable for high temperature duty (e.g. 0 °C to 175 °C).

A.6 Central web thermocouples (structural steelwork test specimen)

This method shall be used for installing 2 mm diameter, stainless steel sheathed thermocouples in the central web. The thermocouple shall be a probe-type thermocouple, and of a suitable length (about 330 mm long is appropriate). The holes in the rear wall of the structural steelwork test specimen leading to the central web thermocouple slots shall have parallel threads, and a thermocouple compression fitting with the same thread, but tapered, shall be fitted to the thermocouple. Install the thermocouple into the slot. Screw the front part of the compression fitting, which has the tapered thread, hand tight into the threaded hole, and then unscrew it one turn. Tighten the rear part of the compression fitting on to the front part with the thermocouple pushed fully into the slot.

ISO 22899-1:2007(E)

Re-screw the front part of the compression fitting into the threaded hole, ensuring that the tip of the thermocouple is in positive contact with the end of the slot.

NOTE Measuring the protruding length provides a check of this.

Annex B (informative)

Example test report

Test details

- Unique test reference:
- Date of report:
- Date of test:
- Test carried out at:
- Report identification code (this should be quoted on every page):

Sponsor

- Whoever is paying for the test.

Product

- Brief description of the product being tested.

Test specimen details

Fabrication

- How and by whom the box or other test specimen was fabricated.

Passive fire protection application

The following information should be obtained from the applicator/commissioner:

- a) method, location and time of application;
- b) applicator company;
- c) whether witnessed by a representative of the test laboratory, commissioner or classification authority;
- d) transport and storage prior to use (where this might affect the material);
- e) surface preparation, primer type and thickness;
- f) number and thickness of layers of passive fire protection material applied;
- g) type of reinforcement (where used), number of layers and position within passive fire protection material; reinforcement material attachment arrangement, overlap locations, distance of overlap and securing details;
- h) overall thickness of material applied;
- i) ambient temperature and relative humidity during application.

- NOTE In addition to the above information, the following details should be included in the test report, if available:
- measurement of surface finish;
 - method of measuring wet coat thickness;
 - density and moisture content of each passive fire protection layer.

Passive fire protection material thickness

- Any measurements of thickness made by the test laboratory.

Passive fire protection material hardness

- Any measurements of hardness made and any conclusions with regard to curing.

Version of test

- Where appropriate, details of any non-standard test configurations should be given together with the reasons for them.

Propane vapour jet fire test facility

General description

- Brief description of test facility.

Instrumentation and accuracy

- What measuring instruments were used and their accuracy. How this is determined (manufacturer's stated accuracy, calibration etc.).
- Method of controlling and monitoring the propane flow rate.

Test conditions

Ambient conditions

- If the test is conducted outdoors, wind speed and direction, whether sunny or cloudy and any precipitation. Indoors and outdoors, ambient temperature.

Fuel flow

- The actual mass flow rate of fuel during the test, how determined, and the total used.

Behaviour and appearance of specimen

Before the test

- The visual appearance of the specimen and any signs of damage.

During the test

- Observations made during the test, perhaps in the form of a table.

Immediately after the test

- Appearance of the test specimen immediately after the jet flame is shut off, including whether burning of the specimen continues and for how long.

On cooling

- Appearance of the passive fire protection material on the test specimen after it has been allowed to cool. This shall include any areas of exposed reinforcement mesh or substrate, the thickness, condition and attachment of char and of unreacted and partially reacted material in the case of passive fire protection materials which are consumed, and the condition of any reinforcement mesh.

Temperature data**Variation of temperature with time**

- Graphs and tables are required by the procedure.

Maximum temperature

- The maximum temperature rise above ambient and the time taken.

NOTE A comparison with the average temperature may indicate how representative the maximum is of the behaviour of the test specimen as a whole.

Comments on the test

- Any comments on how the material performed, any factors which may have influenced that performance. Differences between the test specification and the test as carried out. Any significant, unanticipated circumstances that occurred during the test.

Classification

- When appropriate, the classification rating expressed as indicated in Clause 15.

Bibliography

- [1] ISO 13943, *Fire safety — Vocabulary*
- [2] EN 1363-2, *Fire resistance tests — Part 2: Alternative and additional procedures*
- [3] MATHER, P. and SMART, R D., *Large scale and medium scale jet fire tests*, Offshore Technology Report – OTO 97 079, HSE, 1997
- [4] British Gas plc, *Assessment of the uniformity of the interim jet fire test procedure*, Offshore Technology Report OTH 95 477, HSE, ISBN 0-7176-1215-5, 1996

© ISO 2015

ICS 13.220.50

Price based on 40 pages