

INTERNATIONAL  
STANDARD

ISO  
22880

Second edition  
2016-12-01

---

---

## Castors and wheels — Requirements for castors for swivel chairs

*Roues et roulettes — Exigences pour roulettes pour sièges de bureaux*



Reference number  
ISO 22880:2016(E)



**COPYRIGHT PROTECTED DOCUMENT**

© ISO 2016, Published in Switzerland

All rights reserved. Unless otherwise specified, no part of this publication may be reproduced or utilized otherwise in any form or by any means, electronic or mechanical, including photocopying, or posting on the internet or an intranet, without prior written permission. Permission can be requested from either ISO at the address below or ISO's member body in the country of the requester.

ISO copyright office  
Ch. de Blandonnet 8 • CP 401  
CH-1214 Vernier, Geneva, Switzerland  
Tel. +41 22 749 01 11  
Fax +41 22 749 09 47  
copyright@iso.org  
www.iso.org

# Contents

	Page
<b>Foreword</b> .....	<b>v</b>
<b>Introduction</b> .....	<b>vi</b>
<b>1 Scope</b> .....	<b>1</b>
<b>2 Normative references</b> .....	<b>1</b>
<b>3 Terms and definitions</b> .....	<b>1</b>
<b>4 Dimensions and classification</b> .....	<b>1</b>
4.1 Characteristics.....	1
4.2 Fixing system.....	1
4.3 Castor type.....	1
4.3.1 General.....	1
4.3.2 Type H.....	2
4.3.3 Type W.....	2
4.3.4 Type C.....	2
4.3.5 Type U.....	3
4.4 Dimensions.....	3
<b>5 Requirements for testing</b> .....	<b>3</b>
5.1 General.....	3
5.2 Standard conditions.....	3
5.2.1 Environmental conditions.....	3
5.2.2 Test sequences.....	4
5.3 Impact performance.....	4
5.3.1 Test objectives, apparatus and procedures.....	4
5.3.2 Test values.....	4
5.3.3 Tolerances.....	4
5.3.4 Acceptance criteria.....	5
5.4 Electrical resistance test.....	5
5.4.1 Test objectives, apparatus and procedures.....	5
5.4.2 Test values.....	5
5.4.3 Tolerances.....	5
5.4.4 Acceptance criteria.....	5
5.5 Contact pressure.....	5
5.5.1 Test objectives, apparatus and procedures.....	5
5.5.2 Test values.....	5
5.5.3 Tolerances.....	6
5.5.4 Acceptance criteria.....	6
5.6 Item retention.....	6
5.6.1 Test objectives, apparatus and procedures.....	6
5.6.2 Test values.....	6
5.6.3 Acceptance criteria.....	6
5.7 Static load performance.....	6
5.7.1 Test objectives, apparatus and procedures.....	6
5.7.2 Test values.....	7
5.7.3 Tolerances.....	7
5.7.4 Acceptance criteria.....	7
5.8 Brake performance of Type U castors.....	7
5.8.1 Test objectives, apparatus and procedures.....	7
5.8.2 Test values.....	7
5.8.3 Tolerances.....	7
5.8.4 Acceptance criteria.....	8
5.9 Dynamic test.....	8
5.9.1 Test objectives, apparatus and procedures.....	8
5.9.2 Test values.....	8

5.9.3	Tolerances.....	8
5.9.4	Acceptance criteria.....	9
5.10	Long distance running.....	9
5.10.1	Test objectives, apparatus and procedures.....	9
5.10.2	Test values.....	9
5.10.3	Tolerances.....	9
5.10.4	Acceptance criteria.....	9
5.11	Rolling resistance.....	10
5.11.1	Test objectives, apparatus and procedures.....	10
5.11.2	Test values.....	10
5.11.3	Tolerances.....	10
5.11.4	Acceptance criteria.....	10
5.12	Swivel resistance.....	10
5.12.1	Test objectives, apparatus and procedures.....	10
5.12.2	Test values.....	10
5.12.3	Tolerances.....	10
5.12.4	Acceptance criteria.....	11
<b>6</b>	<b>Conformity.....</b>	<b>11</b>
<b>7</b>	<b>Marking.....</b>	<b>11</b>
7.1	Product marking.....	11
7.2	Marking of electrically conductive or antistatic castors/wheels.....	11
	<b>Bibliography.....</b>	<b>12</b>

## Foreword

ISO (the International Organization for Standardization) is a worldwide federation of national standards bodies (ISO member bodies). The work of preparing International Standards is normally carried out through ISO technical committees. Each member body interested in a subject for which a technical committee has been established has the right to be represented on that committee. International organizations, governmental and non-governmental, in liaison with ISO, also take part in the work. ISO collaborates closely with the International Electrotechnical Commission (IEC) on all matters of electrotechnical standardization.

The procedures used to develop this document and those intended for its further maintenance are described in the ISO/IEC Directives, Part 1. In particular the different approval criteria needed for the different types of ISO documents should be noted. This document was drafted in accordance with the editorial rules of the ISO/IEC Directives, Part 2 (see [www.iso.org/directives](http://www.iso.org/directives)).

Attention is drawn to the possibility that some of the elements of this document may be the subject of patent rights. ISO shall not be held responsible for identifying any or all such patent rights. Details of any patent rights identified during the development of the document will be in the Introduction and/or on the ISO list of patent declarations received (see [www.iso.org/patents](http://www.iso.org/patents)).

Any trade name used in this document is information given for the convenience of users and does not constitute an endorsement.

For an explanation on the meaning of ISO specific terms and expressions related to conformity assessment, as well as information about ISO's adherence to the World Trade Organization (WTO) principles in the Technical Barriers to Trade (TBT) see the following URL: [www.iso.org/iso/foreword.html](http://www.iso.org/iso/foreword.html).

The committee responsible for this document is ISO/TC 110, *Industrial trucks*.

This second edition results from the reinstatement of ISO 22880:2004, which was withdrawn in 2014 and with which it is technically identical.

## **Introduction**

The industry stakeholders have expressed the need for this important International Standard. Therefore, the interested parties agreed to republish the withdrawn document as a new edition.

In order to ensure that the International Standard will be actively used in the ISO member countries worldwide, procedures may be necessary to replace the existing national standards and technical regulations by the International Standard.

Only by these actions will there be the guarantee that products in accordance with International Standards can be shipped worldwide freely without any technical barriers.

# Castors and wheels — Requirements for castors for swivel chairs

## 1 Scope

This document specifies the technical requirements, the appropriate dimensions and the requirements for the testing of castors, with or without braking devices, which will normally be used on swivel chairs.

## 2 Normative references

The following documents are referred to in the text in such a way that some or all of their content constitutes requirements of this document. For dated references, only the edition cited applies. For undated references, the latest edition of the referenced document (including any amendments) applies.

ISO 22878:2004, *Castors and wheels — Test methods and apparatus*

## 3 Terms and definitions

For the purposes of this document, the terms and definitions given in ISO 22877 apply.

ISO and IEC maintain terminological databases for use in standardization at the following addresses:

- IEC Electropedia: available at <http://www.electropedia.org/>
- ISO Online browsing platform: available at <http://www.iso.org/obp>

NOTE Symbols are given in ISO 22878:2004, Annex A.

## 4 Dimensions and classification

### 4.1 Characteristics

The characteristics of a castor are as follows:

- fixing system;
- castor type;
- dimensions.

### 4.2 Fixing system

The fixing system includes the stem and circlip, threaded stem and other fixing systems.

### 4.3 Castor type

#### 4.3.1 General

Castors are classified into four types (H, W, C and U). These all apply to the castor designs illustrated in [Figure 1](#) and [Figure 2](#).

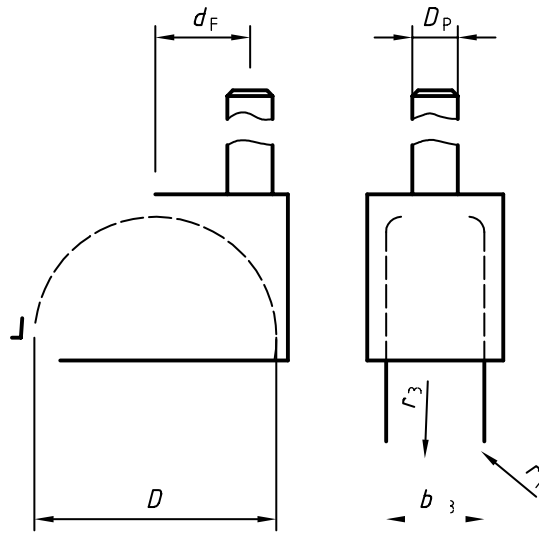

Figure 1 — Single-wheel swivel castor

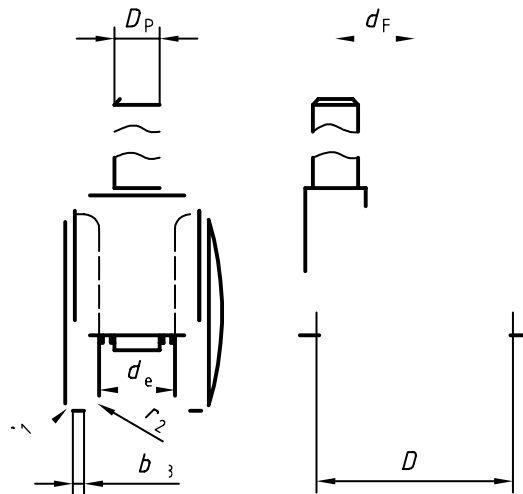

Figure 2 — Twin-wheel castor

#### 4.3.2 Type H

Castors with plain wheels are defined as Type H, hard tread. The wheel shall be one colour over the entire surface.

These castors are suitable for carpeted floors.

#### 4.3.3 Type W

Castors with resilient tyred wheels are defined as Type W, soft tread. The tread shall be of a clearly different colour from the wheel centre.

These castors are suitable for hard stone, wooden or tiled floors, or those featuring non-textiled covering.

#### 4.3.4 Type C

These castors are antistatic or electrically conductive.



These castors should have either Type H or Type W wheels. They may also conform to Type U.

#### 4.3.5 Type U

These castors are for swivel chairs with a built-in braking mechanism.

The castors should have either Type H or Type W wheels. They may also conform to Type C.

NOTE 1 For certain applications, castors for swivel chairs require a built-in braking mechanism that is released when a person sits on the chair to which the castors are fitted, allowing ease of mobility in that position. This braking action is automatically re-applied as the person leaves the chair to prevent the chair rolling away unintentionally.

NOTE 2 The decision regarding the type of castors to be fitted to swivel chairs depends on the chair design and the type of floors and covering in use.

Castors with permanent braking systems are not acceptable.

#### 4.4 Dimensions

Figure 1 and Figure 2 show typical castor designs. Table 1 shows the specified dimensions and the corresponding symbols.

**Table 1**

Dimensions in millimetres

Description	Castor designs	Symbol	Dimension
Wheel diameter	All	$D$	min. 48
Offset	All	$d_F$	min. 18
Tread width	Single wheel	$b_{T3}$	min. 18
	Twin wheel		min. $2 \times 7$
External corner radius	All Type H	$r_1$	min. 6
	All Type W		min. 1,5
External corner radius	All	$r_1$	min. 1,5
Tread curvature	Single wheel castors	$r_3$	min. 110
Wheel spacing	All twin wheel	$d_e$	15 to 22
Minimum stem diameter	All	$D_P$	10 mm or M10

### 5 Requirements for testing

#### 5.1 General

Test methods and apparatus shall be as specified in ISO 22878.

The test values detailed are the minimum required for acceptance

#### 5.2 Standard conditions

##### 5.2.1 Environmental conditions

Tests shall be carried out at a temperature between 17 °C and 23 °C. During the 24 h prior to the test, the sample(s) shall remain at the above temperature in an environment with a relative humidity between 40 % and 70 %.

Sample(s) shall not be artificially cooled during testing.

5.2.2 Test sequences

Tests on electrical resistance, impact, contact pressure, stem retention and static load shall all be carried out with new castors each time.

Another new castor is then taken and the remaining tests shall be carried out in the sequence shown in [Table 2](#).

Table 2

Reference in this document	Test sequence	Castor types	Test procedure given in ISO 22878:2004
<a href="#">5.3</a>	Impact performance	All	4.12
<a href="#">5.4</a>	Electrical resistance	Type C castors	4.4
<a href="#">5.5</a>	Contact pressure	All	4.10
<a href="#">5.6</a>	Stem retention	All	4.17
<a href="#">5.7</a>	Static load performance	All	4.9
<a href="#">5.8</a>	Brake performance	Type U castors (first test)	4.11
<a href="#">5.8</a>	Brake performance	Type U castors (second test)	4.11
<a href="#">5.9</a>	Dynamic	All	4.13
<a href="#">5.10</a>	Long distance running	All	4.14
<a href="#">5.11</a>	Rolling resistance	All	4.15
<a href="#">5.12</a>	Swivel resistance	All	4.16

5.3 Impact performance

5.3.1 Test objectives, apparatus and procedures

These shall be as specified in ISO 22878:2004, 4.12.

5.3.2 Test values

The test values shall be as listed in [Table 3](#).

Table 3

Symbol	Value	Description
<i>m</i>	5 kg	Free-falling mass
<i>h<sub>2</sub></i>	200 mm	Drop height

5.3.3 Tolerances

The tolerances shall be as shown in [Table 4](#).

Table 4

Symbol	Unit	Tolerance	
		Acceptable	Unit
<i>m</i>	kg	+2% 0	kg
<i>h<sub>2</sub></i>	mm	+3 0	mm

### 5.3.4 Acceptance criteria

No part of a castor shall become detached during the tests. Upon completion of the test, the rolling, pivoting or braking performance shall be not impaired.

## 5.4 Electrical resistance test

### 5.4.1 Test objectives, apparatus and procedures

These shall be as specified in ISO 22878:2004, 4.4

### 5.4.2 Test values

The test values shall be as listed in [Table 5](#).

**Table 5**

Symbol	Value	Description
$F_{\max}$	Variable	Load capacity
$F_{17}$	5 % to 10 % of $F_{\max}$	Test load
$R$	Variable	Electrical resistance

### 5.4.3 Tolerances

The tolerances shall be as shown in [Table 6](#).

**Table 6**

Symbol	Unit	Tolerance	
		Acceptable	Unit
$F_{17}$	N	+2% 0	N

### 5.4.4 Acceptance criteria

The resistance,  $R$ , of the sample tested shall be as follows:

- $R \leq 10^5 \Omega$  for conductive castor(s) or wheel(s);
- $10^5 \Omega \leq R \leq 10^7 \Omega$  for antistatic castor(s) or wheels.

## 5.5 Contact pressure

### 5.5.1 Test objectives, apparatus and procedures

These shall be as specified in ISO 22878:2004, 4.10.

### 5.5.2 Test values

The test values shall be as listed in [Table 7](#).

Table 7

Symbol	Value	Description
$F_2$	325 N	Test load
$t_{y1}$	24 h	Time of application of the load

5.5.3 Tolerances

The tolerances shall be as shown in [Table 8](#).

Table 8

Symbol	Unit	Tolerance	
		Acceptable	Unit
$F_2$	N	+2% 0	N
$t_{y1}$	h	+15 0	min

5.5.4 Acceptance criteria

5.5.4.1 Type H castors

The average contact pressure exerted by the wheels on the test surface shall not be less than 10 N/mm<sup>2</sup>.

5.5.4.2 Type W castors

The average contact pressure exerted by the wheels on the test surface shall be not less than 3 N/mm<sup>2</sup> and shall not be more than 5 N/mm<sup>2</sup>.

5.6 Item retention

5.6.1 Test objectives, apparatus and procedures

These shall be as specified in ISO 22878:2004, 4.17.

5.6.2 Test values

The test values shall be as listed in [Table 9](#).

Table 9

Symbol	Value	Description
$F_{min}$	50 N	Minimum pull-out force

5.6.3 Acceptance criteria

The force required to remove the stem from the castor shall be greater than  $F_{min}$ .

5.7 Static load performance

5.7.1 Test objectives, apparatus and procedures

These shall be as specified in ISO 22878:2004, 4.9.

### 5.7.2 Test values

The test values shall be as listed in [Table 10](#).

**Table 10**

Symbol	Value	Description
$F_6$	800 N	Test load
$t_{y1}$	24 h	Time of application of the load
$t_{y2}$	24 h	Elapsed time prior to inspection

### 5.7.3 Tolerances

The tolerances shall be as shown in [Table 11](#).

**Table 11**

Symbol	Unit	Tolerance	
		Acceptable	Unit
$F_6$	N	+2% 0	N
$t_{y1}$	h	+15 0	min
$t_{y2}$	h	±1	h

### 5.7.4 Acceptance criteria

Wheel deformation measured after a time  $t_{y2}$  shall not exceed 3 % of the wheel diameter. Upon completion of the test, the rolling, pivoting or braking performance shall not be impaired.

## 5.8 Brake performance of Type U castors

### 5.8.1 Test objectives, apparatus and procedures

These shall be as specified in ISO 22878:2004, 4.11.

### 5.8.2 Test values

The test values shall be as listed in [Table 12](#).

**Table 12**

Symbol	Value	Description
$F_1$	60/120/150 N (progressive)	Test load (including frame)
$v_3$	50 mm/s	Travel speed

### 5.8.3 Tolerances

The tolerances shall be as shown in [Table 13](#).

Table 13

Symbol	Unit	Tolerance	
		Acceptable	Unit
$F_1$	N	+2% 0	N
$v_3$	mm/s	±5 %	mm/s

5.8.4 Acceptance criteria

For each test load (using three castors), the minimum horizontal tractive force shall be as follows:

- for Type H castors ( $F_{w1}$ ): 11 N;
- for Type W castors ( $F_{w2}$ ): 9 N.

5.9 Dynamic test

5.9.1 Test objectives, apparatus and procedures

These shall be as specified in ISO 22878:2004, 4.13.

5.9.2 Test values

The test values shall be as listed in [Table 14](#).

Table 14

Symbol	Value for Type H-castor	Value for Type W-castor	Description
$F_7$	300 N	300 N	Test load (per castor)
$h_1$	2 mm	3 mm	Height of obstacles
$n_{r2}$	5 000 cycles	30 000 cycles	Number of cycles
$t_{z1}$	3 min	3 min	Running period
$t_{z2}$	2 min	2 min	Pause
$f_z$	6,8 cycles per min	6,8 cycles per min	Frequency

5.9.3 Tolerances

The tolerances shall be as shown in [Table 15](#).

Table 15

Symbol	Unit	Tolerance	
		Acceptable	Unit
$F_7$	N	+2% 0	N
$h_1$	mm	0 -5%	mm
$n_{r2}$	—	+1% 0	—

Table 15 (continued)

Symbol	Unit	Tolerance	
		Acceptable	Unit
$t_{z1}$	min	$\pm 10$	s
$t_{z2}$	min	$\pm 10$	s
$f_z$	cycles/min	$\pm 3 \%$	cycles/min

#### 5.9.4 Acceptance criteria

No castor or a part of a castor shall become detached during the tests. Each castor shall still be capable of carrying out its function at the end of the test programme. Upon completion of the test, the rolling, pivoting or braking performance shall not be impaired.

### 5.10 Long distance running

#### 5.10.1 Test objectives, apparatus and procedures

These shall be as specified in ISO 22878:2004, 4.14.

#### 5.10.2 Test values

The test values shall be as listed in [Table 16](#).

Table 16

Symbol	Values for Type H castors	Values for Type W castors	Description
$F_7$	300 N	300 N	Test load (per castor)
$n_{r2}$	70 000 cycles	20 000 cycles	Number of cycles
$f_z$	6,8 cycles per min	6,8 cycles per min	Frequency

#### 5.10.3 Tolerances

The tolerances shall be as shown in [Table 17](#).

Table 17

Symbol	Unit	Tolerance	
		Acceptable	Unit
$F_7$	kg	+2% 0	kg
$n_{r2}$	—	+1% 0	—
$f_z$	cycles/min	$\pm 3 \%$	cycles/min

#### 5.10.4 Acceptance criteria

No castor or a part of a castor shall become detached during the tests. Each castor shall still be capable of carrying out its function at the end of the test programme. Upon completion of the test, the rolling, pivoting or braking performance shall not be impaired.

## 5.11 Rolling resistance

### 5.11.1 Test objectives, apparatus and procedures

These shall be as specified in ISO 22878:2004, 4.15.

### 5.11.2 Test values

The test values shall be as listed in [Table 18](#).

**Table 18**

Symbol	Value	Description
$F_1$	300 N/600 N/900 N (progressive)	Test load
$v_3$	50 mm/s	Travel speed

### 5.11.3 Tolerances

The tolerances shall be as shown in [Table 19](#).

**Table 19**

Symbol	Unit	Tolerance	
		Acceptable	Unit
$F_1$	N	+2% 0	N
$v_3$	mm/s	±5 %	mm/s

### 5.11.4 Acceptance criteria

For each test load, the horizontal tractive force  $F_{w3}$  shall not exceed 15 % of  $F_8$ .

## 5.12 Swivel resistance

### 5.12.1 Test objectives, apparatus and procedures

These shall be as specified in ISO 22878:2004, 4.16.

### 5.12.2 Test values

The test values shall be as listed in [Table 20](#).

**Table 20**

Symbol	Value	Description
$F_1$	100 N/200 N/300 N (progressive)	Test load (per castor)
$v_3$	50 mm/s	Travel speed

### 5.12.3 Tolerances

The tolerances shall be as shown in [Table 21](#).



Table 21

Symbol	Unit	Tolerance	
		Acceptable	Unit
$F_9$	N	+2% 0	N
$v_3$	mm/s	±5 %	mm/s

The tolerance of the angular position of the castor to the running direction (90°) shall be ±3°.

#### 5.12.4 Acceptance criteria

For each of the loads, the horizontal tractive force  $F_{w4}$  shall not exceed 20 % of  $F_1$ .

## 6 Conformity

On request, the manufacturer shall declare by a certificate of conformity that the castors are in accordance with the requirements as stated in this document.

The type of testing machine shall be stated in the conformity document.

## 7 Marking

### 7.1 Product marking

All the products shall be permanently marked with the name and/or trademark of the manufacturer.

### 7.2 Marking of electrically conductive or antistatic castors/wheels

All products shall bear, on their outer surface, a clearly visible mark as follows:

- antistatic: a white mark and, where appropriate and possible, the word “antistatic”;
- conductive: a yellow mark and, where appropriate and possible, the word “conductive”.

## Bibliography

- [1] ISO 22877, *Castors and wheels — Vocabulary, symbols and multilingual terminology*
- [2] ISO 22880, *Castors and wheels — Requirements for castors for swivel chairs*
- [3] ISO 22881, *Castors and wheels — Requirements for use on manually propelled equipment for institutional applications*
- [4] ISO 22882, *Castors and wheels — Requirements for castors for hospital beds*
- [5] ISO 22883, *Castors and wheels — Requirements for applications up to 1,1 m/s (4 km/h)*
- [6] ISO 22884, *Castors and wheels — Requirements for applications over 1,1 m/s (4 km/h) and up to 4,4 m/s (16 km/h)*



