

INTERNATIONAL
STANDARD

ISO
22879

Second edition
2016-12-01

Castors and wheels — Requirements for castors for furniture

Roues et roulettes — Exigences pour roulettes pour meubles



Reference number
ISO 22879:2016(E)



COPYRIGHT PROTECTED DOCUMENT

© ISO 2016, Published in Switzerland

All rights reserved. Unless otherwise specified, no part of this publication may be reproduced or utilized otherwise in any form or by any means, electronic or mechanical, including photocopying, or posting on the internet or an intranet, without prior written permission. Permission can be requested from either ISO at the address below or ISO's member body in the country of the requester.

ISO copyright office
Ch. de Blandonnet 8 • CP 401
CH-1214 Vernier, Geneva, Switzerland
Tel. +41 22 749 01 11
Fax +41 22 749 09 47
copyright@iso.org
www.iso.org

Contents

	Page
Foreword	v
Introduction	vi
1 Scope	1
2 Normative references	1
3 Terms and definitions	1
4 Dimensions and classification	1
4.1 Characteristics.....	1
4.2 Fixing system.....	1
4.3 Castor type.....	2
4.3.1 General.....	2
4.3.2 Type H.....	3
4.3.3 Type W.....	3
4.3.4 Type C.....	3
4.3.5 Type S.....	3
4.4 Dimensions.....	3
4.5 Performance level.....	4
5 Requirements for testing	4
5.1 General.....	4
5.2 Standard conditions.....	4
5.2.1 Environmental conditions.....	4
5.2.2 Test sequence.....	4
5.3 Impact performance.....	5
5.3.1 Test objectives, apparatus and procedures.....	5
5.3.2 Test values.....	5
5.3.3 Tolerances.....	5
5.3.4 Acceptance criteria.....	5
5.4 Electrical resistance test.....	6
5.4.1 Test objectives, apparatus and procedures.....	6
5.4.2 Test values.....	6
5.4.3 Tolerances.....	6
5.4.4 Acceptance criteria.....	6
5.5 Manual locking device.....	6
5.5.1 Test objectives, apparatus and procedures.....	6
5.5.2 Test values.....	6
5.5.3 Tolerances.....	7
5.5.4 Acceptance criteria.....	7
5.6 Dynamic test.....	7
5.6.1 Test objectives, apparatus and procedures.....	7
5.6.2 Test values.....	7
5.6.3 Tolerances.....	7
5.6.4 Acceptance criteria.....	8
5.7 Rolling resistance.....	8
5.7.1 Test objectives, apparatus and procedures.....	8
5.7.2 Test values.....	8
5.7.3 Tolerances.....	8
5.7.4 Acceptance criteria.....	9
5.8 Swivel resistance.....	9
5.8.1 Test objectives, apparatus and procedures.....	9
5.8.2 Test values.....	9
5.8.3 Tolerances.....	9
5.8.4 Acceptance criteria.....	9
5.9 Static load performance.....	9

ISO 22879:2016(E)

5.9.1	Test objectives, apparatus and procedures.....	9
5.9.2	Test values	9
5.9.3	Tolerances.....	10
5.10	Stem retention.....	10
5.10.1	Test objectives, apparatus and procedures.....	10
5.10.2	Test values	10
5.10.3	Acceptance criteria.....	10
6	Conformity.....	10
7	Marking.....	11
7.1	Product marking.....	11
7.2	Marking of electrically conductive or antistatic castors/wheels.....	11
	Bibliography.....	12

Foreword

ISO (the International Organization for Standardization) is a worldwide federation of national standards bodies (ISO member bodies). The work of preparing International Standards is normally carried out through ISO technical committees. Each member body interested in a subject for which a technical committee has been established has the right to be represented on that committee. International organizations, governmental and non-governmental, in liaison with ISO, also take part in the work. ISO collaborates closely with the International Electrotechnical Commission (IEC) on all matters of electrotechnical standardization.

The procedures used to develop this document and those intended for its further maintenance are described in the ISO/IEC Directives, Part 1. In particular the different approval criteria needed for the different types of ISO documents should be noted. This document was drafted in accordance with the editorial rules of the ISO/IEC Directives, Part 2 (see www.iso.org/directives).

Attention is drawn to the possibility that some of the elements of this document may be the subject of patent rights. ISO shall not be held responsible for identifying any or all such patent rights. Details of any patent rights identified during the development of the document will be in the Introduction and/or on the ISO list of patent declarations received (see www.iso.org/patents).

Any trade name used in this document is information given for the convenience of users and does not constitute an endorsement.

For an explanation on the meaning of ISO specific terms and expressions related to conformity assessment, as well as information about ISO's adherence to the World Trade Organization (WTO) principles in the Technical Barriers to Trade (TBT) see the following URL: www.iso.org/iso/foreword.html.

The committee responsible for this document is ISO/TC 110, *Industrial trucks*.

This second edition results from the reinstatement of ISO 22879:2004, which was withdrawn in 2014 and with which it is technically identical.

Introduction

The industry stakeholders have expressed the need for this important International Standard. Therefore, the interested parties agreed to republish the withdrawn International Standard as a new edition.

In order to ensure that the International Standard will be actively used in the ISO member countries, worldwide, procedures may be necessary to replace the existing national standards and technical regulations by the International Standard.

Only by these actions will there be the guarantee that products in accordance with International Standards can be shipped worldwide freely without any technical barriers.

Castors and wheels — Requirements for castors for furniture

1 Scope

This document specifies the technical requirements, the appropriate dimensions and the requirements for the testing of castors for furniture.

It is applicable to castors for general furniture applications, but specifically excludes those for swivel chairs and other specialized applications.

NOTE Castors for swivel chairs are specified in ISO 22880.

2 Normative references

The following documents are referred to in the text in such a way that some or all of their content constitutes requirements of this document. For dated references, only the edition cited applies. For undated references, the latest edition of the referenced document (including any amendments) applies.

ISO 22878:2004, *Castors and wheels — Test methods and apparatus*

3 Terms and definitions

For the purposes of this document, the terms and definitions given in ISO 22877 apply.

ISO and IEC maintain terminological databases for use in standardization at the following addresses:

- IEC Electropedia: available at <http://www.electropedia.org/>
- ISO Online browsing platform: available at <http://www.iso.org/obp>

NOTE Symbols are given in ISO 22878:2004, Annex A.

4 Dimensions and classification

4.1 Characteristics

The characteristics of a castor are

- fixing system,
- castor type,
- dimensions, and
- performance level.

4.2 Fixing system

The fixing system includes the top plates, stem and circlip, threaded stem and other fixing systems.

Fixings shall be chosen with reference to the application of the castor.

4.3 Castor type

4.3.1 General

Castors are classified into four types (H, W, C and S). These all apply to the castor designs illustrated in [Figure 1](#) to [Figure 3](#).

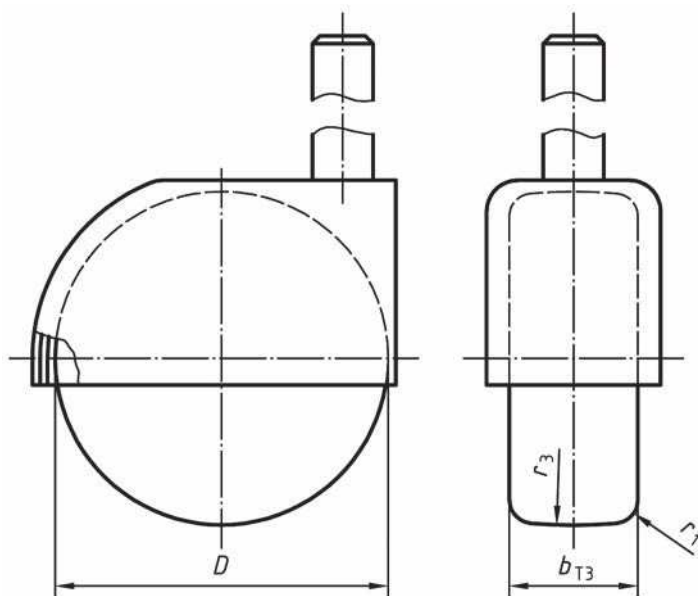

Figure 1 — Single-wheel swivel castor

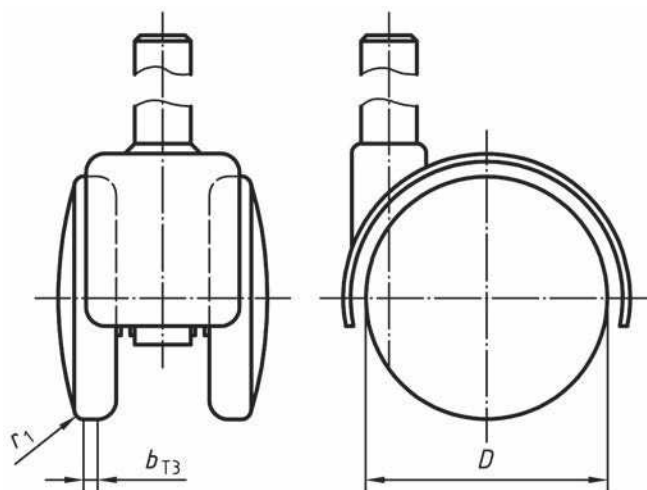

Figure 2 — Twin-wheel swivel castor

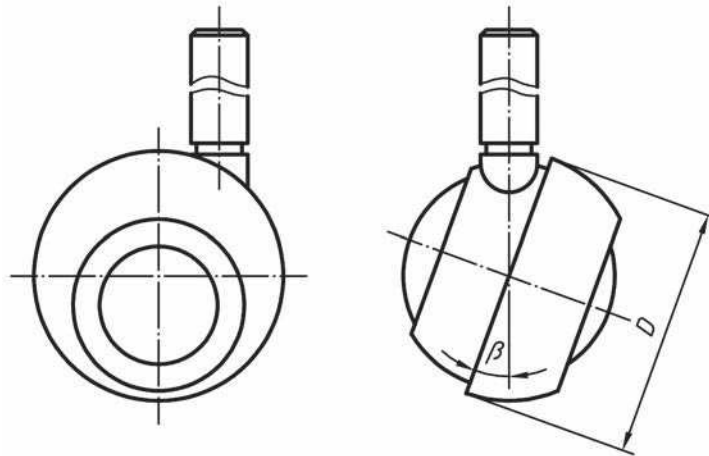

Figure 3 — Inclined axle castor

4.3.2 Type H

Castors with plain wheels are defined as Type H, hard tread.

These castors are suitable for carpeted floors.

4.3.3 Type W

Castors with resilient tyred wheels are defined as Type W, soft tread.

These castors are suitable for hard stone, wooden or tiled floors, or those featuring non-textiled covering.

4.3.4 Type C

These castors are electrically conductive. Type C castors may have a hard or soft tread.

These castors should have either modified Type H or Type W wheels.

4.3.5 Type S

These are inclined axle castors.

4.4 Dimensions

[Figure 1](#) to [Figure 3](#) show typical castor designs. [Table 1](#) shows the specified dimensions and the corresponding symbols.

Table 1

Dimensions in millimetres and angles in degrees

Description	Castor designs	Symbol	Dimension
Wheel diameter	All	D	min. 20
Tread width	Single-wheel castors	b_{T3}	min. 7,5
	Twin-wheel castors		min. 2 × 5
External corner radius	All	r_1	min. 1,5
Tread curvature	Single-wheel castors	r_3	min. 110
Angle of inclination	Inclined axle castors	β	max. 25

The wheel(s) of a fixed castor shall conform to the dimensions shown in [Figure 1](#), [Figure 2](#) or [Figure 3](#) (as appropriate).

4.5 Performance level

The requirements for castors will vary depending on the environment in which they are intended to be used. The levels are shown in [Table 2](#).

Table 2

Level	Load capacity F_{max} (N)
1	100
2	200
3	300
4	400

5 Requirements for testing

5.1 General

Test apparatus and procedures shall be as specified in ISO 22878.

5.2 Standard conditions

5.2.1 Environmental conditions

Tests shall be carried out at a temperature between 17° C and 23° C. During the 24 h prior to the test, the samples shall remain at the specified temperature, in an environment with a relative humidity between 40 % and 70 %.

Samples shall not be artificially cooled during testing.

5.2.2 Test sequence

A new castor shall be taken and the impact test performed.

A second new castor shall be taken and the remaining tests performed in the sequence shown in [Table 3](#).

Table 3

Reference in this document	Test sequence	Castor designs	Test procedure given in ISO 22878:2004
5.3	Impact performance	All	4.12
5.4	Electrical resistance	Type C castors	4.4
5.5	Manual locking device	Castors with manual locking devices	4.6
5.6	Dynamic	All	4.13
5.7	Rolling resistance	All	4.15
5.8	Swivel resistance	Swivel castors	4.16
5.9	Static load	All	4.9
5.10	Stem retention	All	4.17

5.3 Impact performance

5.3.1 Test objectives, apparatus and procedures

These shall be as specified in ISO 22878:2004, 4.12.

5.3.2 Test values

Test values shall be as listed in [Table 4](#).

Table 4

Performance level	Mass of free-falling weight <i>m</i> kg	Drop height <i>h</i> ₂ mm
1	2,5	150
2	5,0	150
3	5,0	200
4	5,0	300

5.3.3 Tolerances

The tolerances shall be as shown in [Table 5](#).

Table 5

Symbol	Unit	Tolerance	
		Acceptable	Unit
<i>m</i>	kg	+2 % 0	kg
<i>h</i> ₂	mm	+3 0	mm

5.3.4 Acceptance criteria

No part of a castor shall become detached during the tests with the loads and drop heights specified in [Table 4](#). On completion of the test, the rolling, pivoting or braking performance shall not be impaired.

5.4 Electrical resistance test

5.4.1 Test objectives, apparatus and procedures

These shall be as specified in ISO 22878:2004, 4.4.

5.4.2 Test values

The test values shall be as listed in [Table 6](#).

Table 6

Symbol	Value	Description
F_{\max}	Variable	Load capacity
F_{17}	5 % to 10 % of F_{\max}	Test load
R	Variable	Electrical resistance

5.4.3 Tolerances

The tolerance shall be as shown in [Table 7](#).

Table 7

Symbol	Unit	Tolerance	
		Acceptable	Unit
F_{17}	N	+2 % 0	N

5.4.4 Acceptance criteria

The resistance, R , of the sample tested shall be

- $R \leq 10^5 \Omega$ for conductive castors or wheels, and
- $10^5 \Omega \leq R \leq 10^7 \Omega$ for antistatic castors or wheels.

5.5 Manual locking device

5.5.1 Test objectives, apparatus and procedures

These shall be as specified in ISO 22878:2004, 4.6.

5.5.2 Test values

The test values shall be as listed in [Table 8](#).

Table 8

Symbol	Value	Description
F_{\max}	Variable	Load capacity
F_{11}	Equal to F_{\max}	Test load
F_{K1}	20 % of F_{\max}	Horizontal tractive force

5.5.3 Tolerances

The tolerances shall be as shown in [Table 9](#).

Table 9

Symbol	Unit	Tolerance	
		Acceptable	Unit
F_{11}	N	+2 % 0	N
F_{K1}	N	+4 % 0	N

5.5.4 Acceptance criteria

The wheel shall not revolve around its axis when a force, F_{K1} , is applied.

5.6 Dynamic test

5.6.1 Test objectives, apparatus and procedures

These shall be as specified in ISO 22878:2004, 4.13.

5.6.2 Test values

The test values shall be as listed in [Table 10](#).

Table 10

Symbol	Value for Type H castor	Value for Type W castor	Value for Type S castor	Description
F_{max}	Variable	Variable	Variable	Load capacity
F_7	125 % of F_{max}	125 % of F_{max}	125 % of F_{max}	Test load
h_1	2 mm	2 mm	0 mm	Height of obstacles
n_{r2}	500 cycles	1 000 cycles	1 000 cycles	Number of cycles
t_{z1}	3 min	3 min	3 min	Running period
t_{z2}	2 min	2 min	2 min	Pause
f_z	6,5 cycles/min	6,5 cycles/min	6,5 cycles/min	Frequency

5.6.3 Tolerances

The tolerances shall be as shown in [Table 11](#).

Table 11

Symbol	Unit	Tolerance	
		Acceptable	Unit
F_7	N	+2 % 0	N
h_1	mm	0 -5 %	mm
n_{r2}	—	+1 % 0	—
t_{z1}	min	±10	s
t_{z2}	min	±10	s
f_z	cycles/min	0 -3 %	cycles/min

5.6.4 Acceptance criteria

No castor or a part of a castor shall become detached during the tests. Each castor shall still be capable of carrying out its function at the end of the test programme. On completion of the test, the rolling, pivoting or braking performance shall not be impaired.

5.7 Rolling resistance

5.7.1 Test objectives, apparatus and procedures

These shall be as specified in ISO 22878:2004, 4.15.

5.7.2 Test values

The test values shall be as listed in [Table 12](#).

Table 12

Symbol	Value	Description
F_{11}	Variable	Test load
F_8	$3 \times F_{11}$	Test load (including frame)
v_3	50 mm/s	Travel speed

5.7.3 Tolerances

The tolerances shall be as shown in [Table 13](#).

Table 13

Symbol	Unit	Tolerance	
		Acceptable	Unit
F_1	N	+2 % 0	N
v_3	mm/s	±5 %	mm/s

5.7.4 Acceptance criteria

The horizontal force, F_{w3} , shall not exceed 15 % of F_8 .

5.8 Swivel resistance

5.8.1 Test objectives, apparatus and procedures

These shall be as specified in ISO 22878:2004, 4.16.

5.8.2 Test values

The test values shall be as listed in [Table 14](#).

Table 14

Symbol	Value	Description
F_{max}	Variable	Load capacity
F_9	F_{max} per castor	Test load (applied load, dependent on the number of castors fitted in the test rig)
v_3	50 mm/s	Travel speed

5.8.3 Tolerances

The tolerances shall be as shown in [Table 15](#).

Table 15

Symbol	Unit	Tolerance	
		Acceptable	Unit
F_9	N	+2 % 0	N
v_3	mm/s	0 -5 %	mm/s

The tolerance of the angular position of the castor to the running direction (90°) shall be $\pm 3^\circ$.

5.8.4 Acceptance criteria

The horizontal tractive force, F_{w3} , shall not exceed 20 % of F_9 .

5.9 Static load performance

5.9.1 Test objectives, apparatus and procedures

These shall be as specified in ISO 22878:2004, 4.9.

5.9.2 Test values

The test values shall be as listed in [Table 16](#).

Table 16

Symbol	Value	Description
F_{\max}	Variable	Load capacity
y_1	2	Load factor
F_6	$F_{\max} \times y_1$	Test load
t_{y1}	24 h	Time of application of the load
t_{y2}	24 h	Elapsed time prior to inspection

5.9.3 Tolerances

The tolerances shall be as shown in [Table 17](#).

Table 17

Symbol	Unit	Tolerance	
		Acceptable	Unit
F_6	N	+2 % 0	N
t_{y1}	h	+15 % 0	min
t_{y2}	h	± 1	h

5.10 Stem retention

5.10.1 Test objectives, apparatus and procedures

These shall be as specified in ISO 22878:2004, 4.17.

5.10.2 Test values

The test values shall be as listed in [Table 18](#).

Table 18

Symbol	Value for circlip stems	Value for other stems	Description
F_{\min}	15 N	30 N	Minimum pull-out force

5.10.3 Acceptance criteria

The minimum force required to remove the stem from the castor shall be not less than F_{\min} .

6 Conformity

On request, the manufacturer shall declare by a certificate of conformity that the castors are in accordance with the requirements as stated in this document.

The type of testing machine shall be stated in the conformity document.

7 Marking

7.1 Product marking

All the products shall be permanently marked with the name and/or trademark of the manufacturer

7.2 Marking of electrically conductive or antistatic castors/wheels

All products shall bear, on their outer surface, a clearly visible mark as follows:

- antistatic: a white mark and, where appropriate and possible, the word “antistatic”;
- conductive: a yellow mark and, where appropriate and possible, the word “conductive”.

Bibliography

- [1] ISO 22877, *Castors and wheels — Vocabulary, symbols and multilingual terminology*
- [2] ISO 22880, *Castors and wheels — Castors for furniture — Requirements for castors for swivel chairs*
- [3] ISO 22881, *Castors and wheels — Requirements for use on manually propelled equipment for institutional applications*
- [4] ISO 22882, *Castors and wheels — Requirements for castors for hospital beds*
- [5] ISO 22883, *Castors and wheels — Requirements for applications up to 1,1 m/s (4 km/h)*
- [6] ISO 22884, *Castors and wheels — Requirements for applications over 1,1 m/s (4 km/h) and up to 4,4 m/s (16 km/h)*

