**Destructive tests on welds in metallic
materials — Hardness testing of narrow
joints welded by laser and electron beam
(Vickers and Knoop hardness tests)**

*Essais destructifs des soudures sur matériaux métalliques — Essais de
dureté sur joints étroits soudés par faisceau d'électrons et faisceau
laser (Essais de dureté Vickers et Knoop)*



PDF disclaimer

This PDF file may contain embedded typefaces. In accordance with Adobe's licensing policy, this file may be printed or viewed but shall not be edited unless the typefaces which are embedded are licensed to and installed on the computer performing the editing. In downloading this file, parties accept therein the responsibility of not infringing Adobe's licensing policy. The ISO Central Secretariat accepts no liability in this area.

Adobe is a trademark of Adobe Systems Incorporated.

Details of the software products used to create this PDF file can be found in the General Info relative to the file; the PDF-creation parameters were optimized for printing. Every care has been taken to ensure that the file is suitable for use by ISO member bodies. In the unlikely event that a problem relating to it is found, please inform the Central Secretariat at the address given below.

© ISO 2005

All rights reserved. Unless otherwise specified, no part of this publication may be reproduced or utilized in any form or by any means, electronic or mechanical, including photocopying and microfilm, without permission in writing from either ISO at the address below or ISO's member body in the country of the requester.

ISO copyright office
Case postale 56 • CH-1211 Geneva 20
Tel. + 41 22 749 01 11
Fax + 41 22 749 09 47
E-mail copyright@iso.org
Web www.iso.org

Published in Switzerland

Contents

Page

Foreword.....	iv
Introduction	v
1 Scope	1
2 Normative references	1
3 General.....	2
4 Symbols and abbreviated terms	2
5 Preparation of test specimens	3
6 Test procedure	3
6.1 General.....	3
6.2 Type of test.....	3
6.3 Test location requirements.....	4
6.4 Individual indentation (type E test).....	6
6.5 Rows of indentations (type R test).....	8
7 Test results	11
8 Test report	11
Annex A (informative) Selection of test force	12
Annex B (informative) Example of a test report format for type E hardness test.....	14
Annex C (informative) Example of a test report format for type R hardness test	15
Bibliography	16

Foreword

ISO (the International Organization for Standardization) is a worldwide federation of national standards bodies (ISO member bodies). The work of preparing International Standards is normally carried out through ISO technical committees. Each member body interested in a subject for which a technical committee has been established has the right to be represented on that committee. International organizations, governmental and non-governmental, in liaison with ISO, also take part in the work. ISO collaborates closely with the International Electrotechnical Commission (IEC) on all matters of electrotechnical standardization.

International Standards are drafted in accordance with the rules given in the ISO/IEC Directives, Part 2.

The main task of technical committees is to prepare International Standards. Draft International Standards adopted by the technical committees are circulated to the member bodies for voting. Publication as an International Standard requires approval by at least 75 % of the member bodies casting a vote.

Attention is drawn to the possibility that some of the elements of this document may be the subject of patent rights. ISO shall not be held responsible for identifying any or all such patent rights.

ISO 22826 was prepared by Technical Committee ISO/TC 44, *Welding and allied processes*, Subcommittee SC 5, *Testing and inspection of welds*.

Introduction

Requests for official interpretation of any aspect of this International Standard should be directed to the Secretariat of ISO/TC 44/SC 5 via your national standards body. A complete listing of these bodies can be found at www.iso.org

Destructive tests on welds in metallic materials — Hardness testing of narrow joints welded by laser and electron beam (Vickers and Knoop hardness tests)

1 Scope

This International Standard specifies the requirements for hardness testing of transverse sections of narrow laser and electron beam welded joints in metallic materials. It covers Vickers and Knoop hardness tests in accordance with ISO 6507-1 and ISO 4545, respectively, with test forces of 0,098 N to just under 98 N (HV 0,01 to just under HV 10) for the Vickers hardness test and test forces up to and including 9,8 N (just under HK 1) for the Knoop hardness test.

This International Standard is applicable to welds made with or without filler wire. It may not be applicable to the testing of wider hybrid laser/arc welds.

International Standards for hardness testing of welds without a narrow profile are ISO 9015-1 and ISO 9015-2.

2 Normative references

The following referenced documents are indispensable for the application of this document. For dated references, only the edition cited applies. For undated references, the latest edition of the referenced document (including any amendments) applies.

ISO 4545, *Metallic materials — Hardness test — Knoop test*

ISO 4546, *Metallic materials — Hardness test — Verification of Knoop hardness testing machines*

ISO 4547, *Metallic materials — Hardness test — Calibration of standardized blocks to be used for Knoop hardness testing machines*

ISO 6507-1, *Metallic materials — Vickers hardness test — Part 1: Test method*

ISO 6507-2:—¹⁾, *Metallic materials — Vickers hardness test — Part 2: Verification and calibration of testing machines*

ISO 6507-3:—²⁾, *Metallic materials — Vickers hardness test — Part 3: Calibration of reference blocks*

ISO 10250, *Metallic materials — Hardness testing — Tables of Knoop hardness values for use in tests made on flat surfaces*

ISO/TR 16060, *Destructive tests on welds in metallic materials — Etchants for macroscopic and microscopic examination*

1) To be published. (Revision of ISO 6507-2:1997)

2) To be published. (Revision of ISO 6507-3:1997)

3 General

Hardness testing shall be carried out in accordance with ISO 6507-1, ISO 6507-2 and ISO 6507-3 for the Vickers hardness test, and ISO 4545, ISO 4546 and ISO 4547 for the Knoop hardness test.

Testing is carried out to determine the range of hardness values in the parent metal (both parent metals for dissimilar-metal joints), the heat-affected zone and the weld metal. This can be achieved by carrying out hardness tests as either individual indentations or groups of indentations (type E test) or as rows of indentations (type R test).

Testing should preferably be carried out at a temperature of $(23 \pm 5) ^\circ\text{C}$. If the test is carried out at a temperature outside this range, it shall be noted in the test report.

Microhardness testing results are affected by vibrations, therefore testing shall be carried out in a vibration-free location.

4 Symbols and abbreviated terms

For the purposes of this International Standard, the abbreviations given in Table 1 apply.

Table 1 — Symbols and abbreviated terms

Symbol	Meaning	Unit
HAZ	Heat-affected zone	—
E	Individual indentation	—
R	Row of indentations	—
HV	Vickers hardness	a
HK	Knoop hardness	b
<i>L</i>	Distance between the centre points of the indentations	mm
<i>M</i>	Recommended distance between the centre points of the indentations in R	mm
<i>W</i>	Distance between the centre points of the indentations in heat-affected zone and fusion line	mm
<i>d_V</i>	Diagonal length of the indentation in a Vickers hardness test	mm
<i>d_{KL}</i>	Long diagonal length of the indentation in a Knoop hardness test	mm
<i>d_{KS}</i>	Short diagonal length of the indentation in a Knoop hardness test	mm
<i>h</i>	Weld penetration depth	mm
<i>t</i>	Thickness of test specimen	mm
a See ISO 6507-1. b See ISO 4545 and ISO 10250.		

5 Preparation of test specimens

Test specimens shall be prepared in accordance with ISO 6507-1 or ISO 4545.

A cross-section of the test piece shall be taken by mechanical cutting, usually transverse to the welded joint. This operation and the subsequent preparation of the surface shall be carried out without heating to a temperature high enough to cause softening or hardening of the surface.

The surface to be tested shall be properly prepared and preferably etched in accordance with ISO/TR 16060, so that accurate measurements of the diagonal length of indentations can be obtained in the different zones of the welded joint.

6 Test procedure

6.1 General

Figure 1 shows typical areas for the location of groups of indentations. Numbers 1 and 2 refer to the weld metal, numbers 3 to 6 refer to the heat-affected zone (HAZ), and numbers 7 and 8 refer to the parent metal.

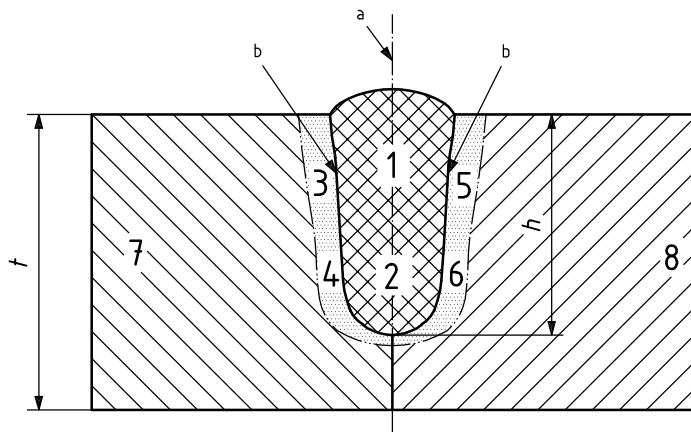

Key

- 1, 2 weld metal
- 3, 4, 5, 6 heat-affected zone (HAZ)
- 7, 8 parent metal

a Centre of the weld metal.

b Fusion line.

Figure 1 — Location of group indentations for Vickers and Knoop hardness testing

When the type of welded joint is different from those shown in the examples, a test procedure appropriate to the type of joint shall be carried out.

6.2 Type of test

Type E or type R tests shall be carried out with the indentations located in accordance with Figures 2 and 3 for type E tests and Figures 4 and 5 for type R tests. The type of test shall be at the discretion of the test operator unless otherwise specified. The type of test used shall be recorded.

6.3 Test location requirements

When the parent metal thickness, t , or the penetration depth, h , is 4 mm or less, the indentations in the weld metal and HAZ shall be located in a line at the centre of the plate thickness, i.e. at $t/2$, or at the mid-point of the penetration depth, i.e. at $h/2$, as shown in Figures 2a) and 2c).

When t or h is greater than 4 mm, the indentations shall be located in a line at a distance within 2 mm of the top surface and back surface (or the bottom part of the penetration) as shown in Figures 2b) and 2d). In the case of double fillet welds with full joint penetration, the indentation shall also be located at the centre part of overlapped fusion zone as shown in Figure 2d).

Dimensions in millimetres

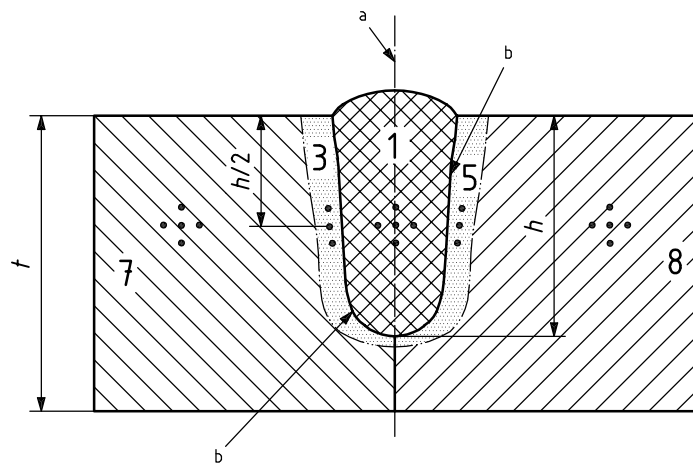

a) Location of indentations — Penetration depth $h \leq 4$ mm

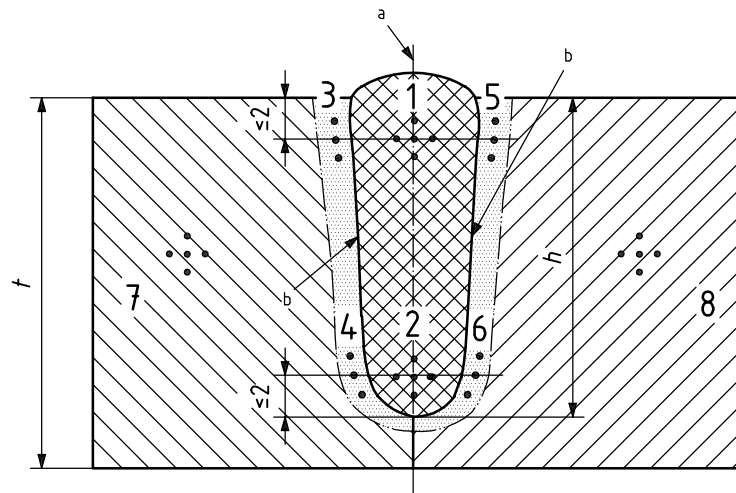

b) Location of indentations — Penetration depth $h > 4$ mm

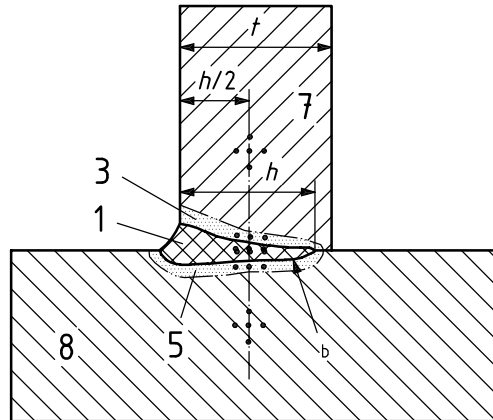

c) Location of indentations — Penetration depth h or $t \leq 4$ mm

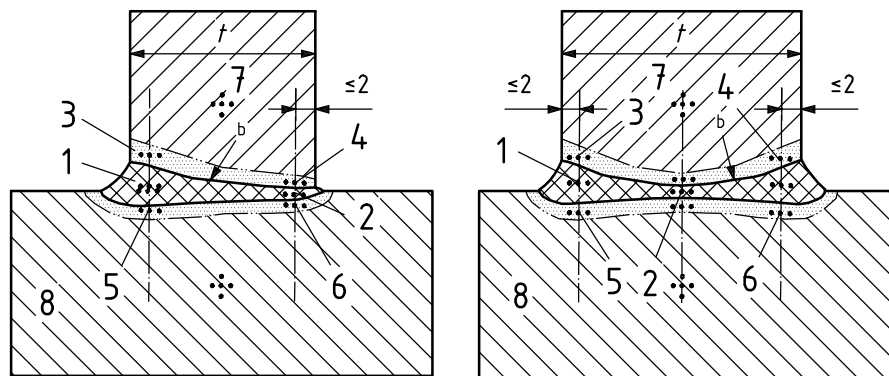

d) Location of indentations — Penetration depth h or $t > 4$ mm

Key

- 1, 2 weld metal
- 3, 4, 5, 6 heat-affected zone (HAZ)
- 7, 8 parent metal

- a Centre of the weld metal.
- b Fusion line.

Figure 2 — Location of indentations for thin and thick plates — Type E test

For hardenable ferrous metals, the distance between the centre of any indentation and the edge of the test piece shall be:

- at least 2,5 times the mean diagonal length of the indentation for Vickers hardness testing;
- the short diagonal length of the indentation for Knoop hardness testing.

For non-hardenable ferrous and nonferrous metals, the distance between the centre of any indentation and the edge of the test piece shall be:

- at least 3 times the mean diagonal length of indentation for the Vickers hardness test;
- the short diagonal length of indentation for Knoop hardness test.

The distance, L , between the centres of two adjacent indentations shall be in accordance with Table 2 for type E tests and Table 4 for type R tests.

NOTE It is recommended that the same test force be used for testing the weld metal for the whole test.

Table 2 — Distance, L , between the centre points of indentations — Type E test

Test method	Parent metal	Distance between centre points, L
Vickers hardness test (HV)	Hardenable ferrous metals	$L \geq 3d_V$
	Non-hardenable ferrous and nonferrous metals	$L \geq 6d_V$
Knoop hardness test (HK)	Hardenable ferrous metals	$L \geq 3d_{KL}$ in long diagonal direction $L \geq 3d_{KS}$ in short diagonal direction
	Non-hardenable ferrous and nonferrous metals	$L \geq 6d_{KL}$ in long diagonal direction $L \geq 6d_{KS}$ in short diagonal direction

6.4 Individual indentation (type E test)

6.4.1 Weld metal hardness test

Hardness testing of the weld metal shall be carried out at a minimum of three points: in the centre and the upper and lower areas and/or on the left and right sides as shown in Figure 3. The mean hardness of all the indentations shall be determined. For larger test forces, using the Vickers hardness test, e.g. 49 N (HV 5) and 98 N (HV 10), the number of indentations can be reduced.

The diagonal length of the indentation, d_V or d_{KS} , for hardness testing of the weld metal shall be 1/10th or less of the width of the weld metal to be measured. The test force and load shall be selected in accordance with Table 3.

NOTE The approximate indentation length for each test force and material hardness is included for information in Table A.1 for Vickers hardness testing and Table A.2 for Knoop hardness testing.

6.4.2 HAZ hardness test

Hardness testing shall be carried out at three points in the HAZ along the fusion line as shown in Figures 3a) and 3b).

The test force used for the HAZ hardness indentations shall be the same as that used for the measurement of hardness in the weld metal. In the case of the HAZ hardness test, the distance W between the centre of the indentation and the fusion line shall not be less than $0,5d_V$ or $0,5d_{KS}$ and shall not exceed the indentation length, d_V or $2d_{KS}$, as shown in Figures 3a) and 3b).

6.4.3 Parent metal hardness test

Hardness testing of the parent metal shall be carried out at a minimum of three points in thermally unaffected parent metal. The measurement location shall be recorded in the test report.

When testing individual locations, the areas shall be numbered as shown in Figure 1.

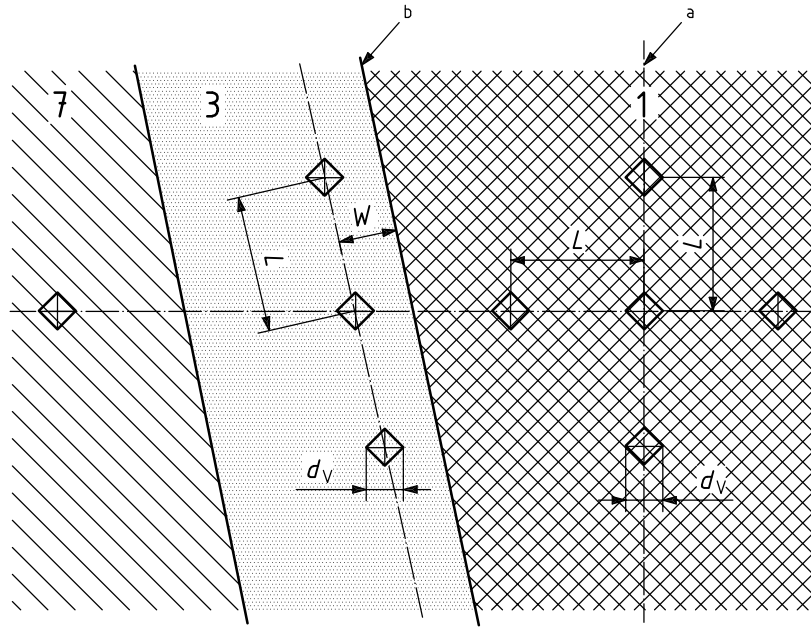

a) Vickers hardness ($d_V/2 \leq W \leq d_V$)

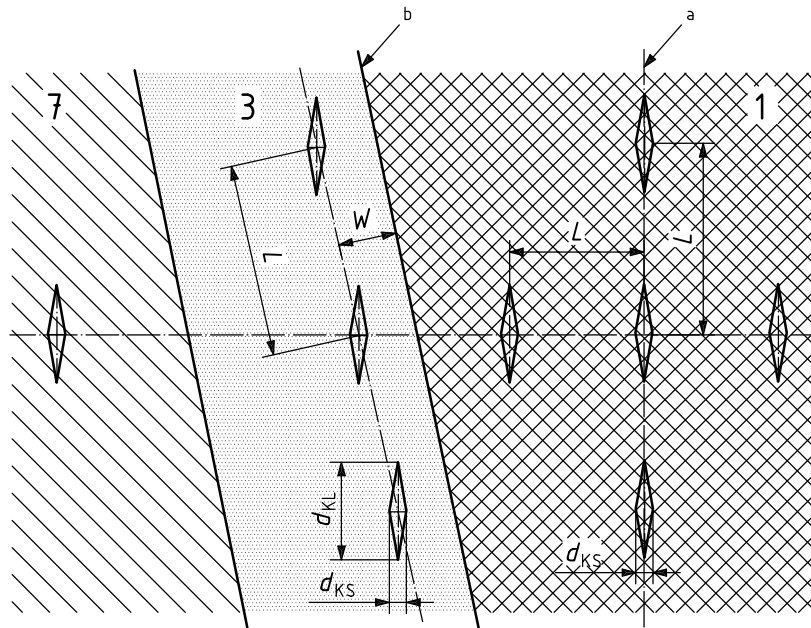

b) Knoop hardness ($d_{KS}/2 \leq W \leq 2d_{KS}$)

Key

- 1 weld metal
- 3 heat-affected zone (HAZ)
- 7 parent metal
- a Centre of the weld metal.
- b Fusion line.

Figure 3 — Location of indentations in the weld metal and HAZ — Type E test

Table 3 — Hardness loads and test forces

Load		Nominal test force N
Vickers hardness test	Knoop hardness test	
HV 0,01	HK 0,01	0,098 07
HV 0,015	—	0,147 1
HV 0,02	HK 0,02	0,196 1
HV 0,025	HK 0,025	0,245 2
HV 0,05	HK 0,05	0,490 3
HV 0,1	HK 0,1	0,980 7
HV 0,2	HK 0,2	1,961
HV 0,3	HK 0,3	2,942
HV 0,5	HK 0,5	4,903
HV 1	HK 1	9,807
HV 2	—	19,61
HV 3	—	29,42
HV 5	—	49,03
HV 10	—	98,07

6.5 Rows of indentations (type R test)

Figure 4 gives examples of the locations for making hardness tests in rows. Additional rows and/or positions may be specified, for example in an application standard. The locations of all indentations shall be recorded in the test report.

For non-hardenable ferrous and nonferrous metals such as austenitic stainless steel, copper, light metals, lead, tin and their alloys, the rows on the bottom side of the welds may not be necessary.

The number and spacing of the indentations shall be sufficient to define hardened or softened regions due to welding. The recommended distance between the centre points of the indentations in the weld metal and HAZ is given in Table 4.

For metals which harden in the HAZ as a result of welding, two additional indentations in the HAZ shall be made at a distance W within $d_V/2 \leq W \leq d_V$ for Vickers hardness and $d_{KS}/2 \leq W \leq 2d_{KS}$ for Knoop hardness as shown in Figure 5.

Dimensions in millimetres

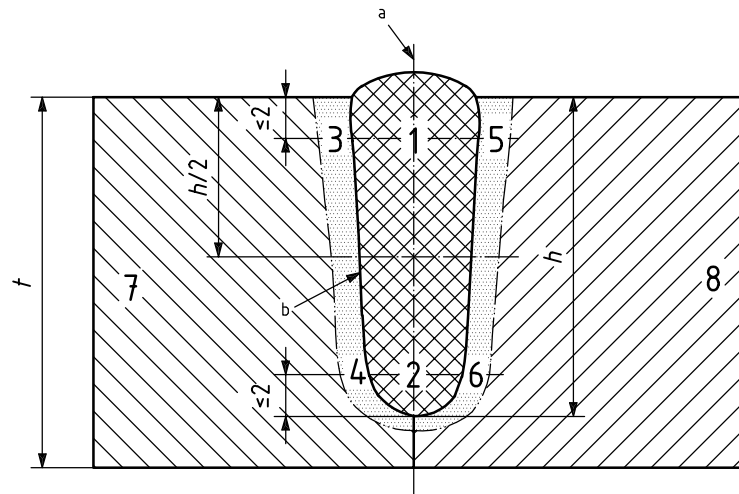

Key

- 1, 2 weld metal
- 3, 4, 5, 6 heat-affected zone (HAZ)
- 7, 8 parent metal

- a Centre of the weld metal.
- b Fusion line.

Figure 4 — Location of indentations — Type R test

Table 4 — Recommended distance M (mm) between the centre point of indentations in the weld metal and HAZ for the row of indentations — Type R test

Hardness symbol	Recommended distance between indentations, M^a	
	mm	
	Hardenable ferrous metals	Non-hardenable ferrous and non-ferrous metals
HV 0,01	0,1	0,3 to 1
HV 0,10	0,2	0,6 to 2
HV 1	0,5	1,5 to 4
HV 5,00	0,7	2,5 to 5
HV 10,0	1,0	3 to 5
HK 0,01	0,1	0,3 to 1
HK 0,10	0,2	0,6 to 2
HK 1	0,3	1,5 to 4

^a The distance of any indentation from the previous indentation shall not be less than the value allowed for the previous indentation in Table 2.

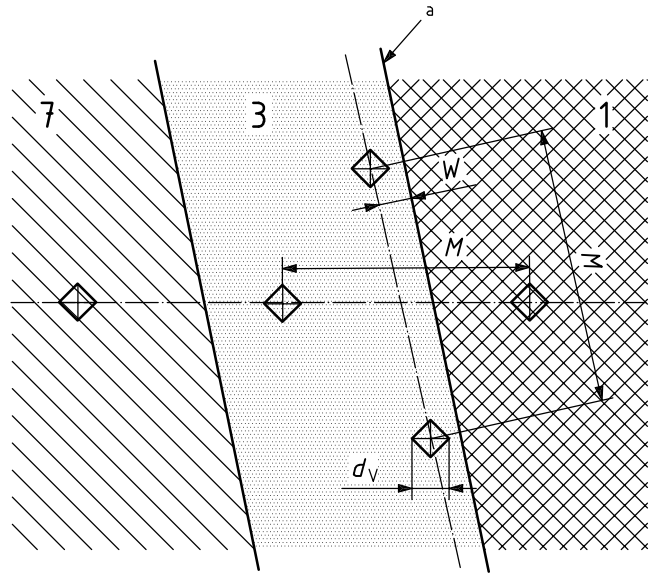

a) Vickers hardness ($d_V/2 \leq W \leq d_V$)

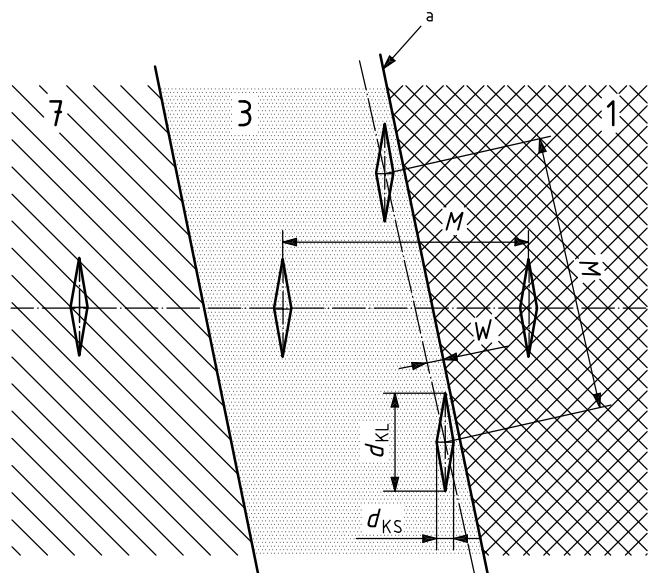

b) Knoop hardness ($d_{KS}/2 \leq W \leq 2d_{KS}$)

- Key**
- 1 weld metal
 - 3 heat-affected zone (HAZ)
 - 7 parent metal
 - a Fusion line.

Figure 5 — Location of additional indentations in the HAZ for hardenable metals — Type R test

7 Test results

The hardness values shall be recorded in relation to the positions of the indentations.

8 Test report

A test report is required. The use of the format given in Annexes B and C is recommended but other formats may be used provided they contain all the required information. The report shall include at least the following:

- a) the test temperature;
- b) the parent metal(s), and the thickness and dimension of the joint;
- c) the type of weld, laser or electron beam, the type of machine and the welding conditions;
- d) the type of hardness test, E or R (Vickers or Knoop), and the hardness symbols;
- e) identification of the test machine (including calibration test block results and date of calibration test);
- f) the locations of the indentations;
- g) each hardness value and the average hardness value;
- h) the date of the test;
- i) the person who carried out the test;
- j) identification or a description of the test specimen.

Annex A (informative)

Selection of test force

Tables A.1 and A.2 show examples of the indentation length that can be estimated from the hardness and load for both the Vickers and Knoop hardness tests. These lengths are given by Equation (A.1) for the Vickers hardness test and Equation (A.2) for the Knoop hardness test.

Table A.1 — Approximate diagonal length d_V (mm) of the indentation as a function of the hardness of the metal and the test force in the Vickers hardness test

Vickers hardness HV	Test force, F N							
	0,098	0,980	1,96	4,90	9,80	19,6	49	98
	Hardness symbol							
	HV 0,01	HV 0,1	HV 0,2	HV 0,5	HV 1	HV 2	HV 5	HV 10
Diagonal length, d_V								
50	0,020	0,061	0,086	0,136	0,193	0,272	0,431	0,609
100	—	0,043	0,061	0,096	0,136	0,193	0,304	0,431
150	—	0,035	0,050	0,079	0,111	0,157	0,249	0,352
200	—	0,030	0,043	0,068	0,096	0,136	0,215	0,304
250	—	0,027	0,039	0,061	0,086	0,122	0,193	0,272
300	—	0,025	0,035	0,056	0,079	0,111	0,176	0,249
350	—	0,023	0,033	0,051	0,073	0,103	0,163	0,230
400	—	0,022	0,030	0,048	0,068	0,096	0,152	0,215
450	—	0,020	0,029	0,045	0,064	0,091	0,144	0,203
500	—	—	0,027	0,043	0,061	0,086	0,136	0,193
550	—	—	0,028	0,041	0,058	0,082	0,130	0,184
600	—	—	0,025	0,039	0,056	0,079	0,124	0,176
650	—	—	0,024	0,038	0,053	0,076	0,119	0,169
700	—	—	0,023	0,036	0,051	0,073	0,115	0,163
750	—	—	0,022	0,035	0,050	0,070	0,111	0,157
800	—	—	0,022	0,034	0,048	0,068	0,108	0,152
850	—	—	0,021	0,033	0,047	0,066	0,104	0,148

Relation between Vickers hardness and indentation length:

$$\text{Vickers hardness (HV)} = 0,189\ 1 \times F d_V^2 \tag{A.1}$$

where

F is the test force (N);

d_V is the average diagonal length of indentation (mm).

Table A.2 — Approximate long diagonal length d_{KL} (mm) of the indentation as a function of the hardness of the metal and the test force in the Knoop hardness test

Knoop hardness HK	Test force, F N							
	0,098 0	0,196	0,490	0,980	1,96	2,94	4,90	9,80
	Hardness symbol							
	HK 0,01	HK 0,02	HK 0,05	HK 0,1	HK 0,2	HK 0,3	HK 0,5	HK 1
Long diagonal length, d_{KL} ^a								
050	0,053	0,075	0,119	0,168	—	—	—	—
100	0,038	0,053	0,084	0,119	0,169	—	—	—
150	0,031	0,043	0,069	0,097	0,138	0,169	—	—
200	0,027	0,038	0,060	0,084	0,119	0,146	0,189	—
250	0,024	0,034	0,053	0,075	0,107	0,131	0,169	—
300	0,022	0,031	0,049	0,069	0,097	0,119	0,154	—
350	0,020	0,028	0,045	0,064	0,090	0,110	0,142	—
400	—	0,027	0,042	0,060	0,084	0,103	0,133	0,189
450	—	0,025	0,040	0,056	0,079	0,097	0,126	0,178
500	—	0,024	0,038	0,053	0,075	0,092	0,119	0,169
550	—	0,023	0,036	0,051	0,072	0,088	0,114	0,161
600	—	0,022	0,034	0,049	0,069	0,084	0,109	0,154
650	—	0,021	0,033	0,047	0,066	0,081	0,105	0,148
700	—	0,020	0,032	0,045	0,064	0,078	0,101	0,143
750	—	—	0,031	0,043	0,062	0,075	0,097	0,138
800	—	—	0,030	0,042	0,060	0,073	0,094	0,133
850	—	—	0,029	0,041	0,058	0,071	0,091	0,129

^a The short diagonal length d_{KS} is approximately 1/7th smaller than the long diagonal length d_{KL} .

Relation between Knoop hardness and indentation length:

$$\text{Knoop hardness (HK)} = 1,451 \times F/d_{KL}^2 \quad (\text{A.2})$$

where

F is the test force (N);

d_{KL} is the long diagonal length of indentation (mm).

Annex B (informative)

Example of a test report format for type E hardness test

Type E hardness test: _____ [indicate Vickers/Knoop test and hardness symbol (e.g. HV 0,01 or HK 0,3)]

Identification of the test machine: _____

Test temperature: _____

Parent metal: _____

Thickness of material: _____

Type of laser/electron beam: _____

Type of weld: _____

Welding conditions: _____

Filler materials: _____

Post-weld heat treatment and/or ageing: _____

Date of test: _____

Signoff person doing the test: _____

Test specimen identification: _____

Notes: _____

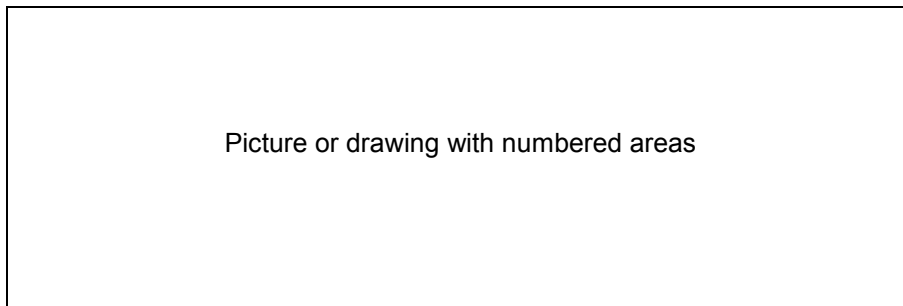

Area	Position of indentations	Individual hardness values ^a					Average hardness
1	Weld metal, top						
2	Weld metal, bottom						
3	Heat-affected zone, top of weld						
4	Heat-affected zone, bottom of weld						
5	Heat-affected zone, top of weld						
6	Heat-affected zone, bottom of weld						
7	Parent metal						
8	Parent metal						

^a Indication of test force in accordance with ISO 6507-1 or ISO 4545.

Annex C
(informative)

Example of a test report format for type R hardness test

Type R hardness test: _____ [indicate Vickers/Knoop test and hardness symbol (e.g. HV 0,01 or HK 0,3)]

Identification of the test machine: _____

Test temperature: _____

Parent metal: _____

Thickness of material: _____

Type of weld: _____

Type of laser/electron beam: _____

Welding conditions: _____

Filler materials: _____

Post weld heat treatment and/or ageing: _____

Brief designation of rows of indentations: _____

Date of test: _____

Signoff person doing the test: _____

Test specimen identification: _____

Notes: _____

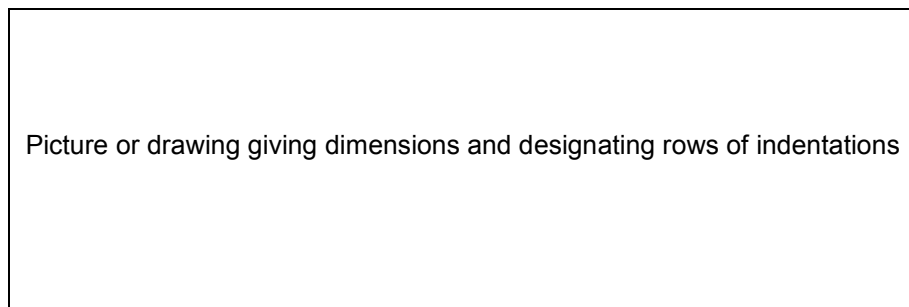

Picture or drawing giving dimensions and designating rows of indentations

Hardness									
HV ^a									

Centre of weld

Distance from weld centre (mm)

^a Indication of test force in accordance with ISO 6507-1 or ISO 4545.

Bibliography

- [1] ISO 9015-1, *Destructive tests on welds in metallic materials — Hardness testing — Part 1: Hardness test on arc welded joints*
- [2] ISO 9015-2, *Destructive tests on welds in metallic materials — Hardness testing — Part 2: Microhardness testing of welded joints*
- [3] ISO 14271, *Vickers hardness testing of resistance spot, projection and seam welds (low load and microhardness)*

ICS 25.160.40

Price based on 16 pages