

INTERNATIONAL STANDARD

ISO 22825

Second edition
2012-05-15

Non-destructive testing of welds — Ultrasonic testing — Testing of welds in austenitic steels and nickel-based alloys

*Contrôle non destructif des assemblages soudés — Contrôle par
ultrasons — Contrôle des soudures en aciers austénitiques et en
alliages à base nickel*



Reference number
ISO 22825:2012(E)

© ISO 2012

ISO 22825:2012(E)



COPYRIGHT PROTECTED DOCUMENT

© ISO 2012

All rights reserved. Unless otherwise specified, no part of this publication may be reproduced or utilized in any form or by any means, electronic or mechanical, including photocopying and microfilm, without permission in writing from either ISO at the address below or ISO's member body in the country of the requester.

ISO copyright office
Case postale 56 • CH-1211 Geneva 20
Tel. + 41 22 749 01 11
Fax + 41 22 749 09 47
E-mail copyright@iso.org
Web www.iso.org

Published in Switzerland

Contents

Page

Foreword	iv
Introduction	v
1 Scope	1
2 Normative references	1
3 Terms and definitions	2
4 Information required prior to testing	2
4.1 Items to be defined by specification	2
4.2 Specific information required by the operator prior to testing	2
5 Personnel	3
6 Equipment	3
7 Range setting for compression waves	3
8 Sensitivity setting	4
8.1 General	4
8.2 Use of side-drilled holes	4
8.3 Use of other reference reflectors	5
9 Test procedure and ultrasonic techniques	5
9.1 Development of the test procedure	5
9.2 Content of the procedure	5
9.3 Selection of ultrasonic technique(s)	6
9.4 Optimization of technique and draft of procedure	7
9.5 Practical implications of the use of refracted compression waves	7
10 Classification and sizing of indications	8
11 Testing of welds	8
11.1 General	8
11.2 Surface condition and couplant fluid	8
11.3 Parent metal testing	8
11.4 Scanning	8
11.5 Evaluation of indications	9
12 Test report	9
12.1 General data	9
12.2 Information related to equipment	9
12.3 Information related to testing technique	9
12.4 Results of testing	10
Annex A (informative) Compression wave angle beam techniques	11
Annex B (informative) Stainless steel calibration blocks for range setting	17
Annex C (informative) Reference blocks for sensitivity setting	19
Bibliography	22

ISO 22825:2012(E)

Foreword

ISO (the International Organization for Standardization) is a worldwide federation of national standards bodies (ISO member bodies). The work of preparing International Standards is normally carried out through ISO technical committees. Each member body interested in a subject for which a technical committee has been established has the right to be represented on that committee. International organizations, governmental and non-governmental, in liaison with ISO, also take part in the work. ISO collaborates closely with the International Electrotechnical Commission (IEC) on all matters of electrotechnical standardization.

International Standards are drafted in accordance with the rules given in the ISO/IEC Directives, Part 2.

The main task of technical committees is to prepare International Standards. Draft International Standards adopted by the technical committees are circulated to the member bodies for voting. Publication as an International Standard requires approval by at least 75 % of the member bodies casting a vote.

Attention is drawn to the possibility that some of the elements of this document may be the subject of patent rights. ISO shall not be held responsible for identifying any or all such patent rights.

ISO 22825 was prepared by the European Committee for Standardization (CEN) Technical Committee TC 121, *Welding*, Sub-committee SC 5, *Testing of welds*, in collaboration with Technical Committee ISO/TC 44, *Welding and allied processes*, Subcommittee SC 5, *Testing and inspection of welds*, in accordance with the Agreement on technical cooperation between ISO and CEN (Vienna Agreement).

This second edition cancels and replaces the first edition (ISO 22825:2006), which has been technically revised.

The main changes are the addition of annexes on:

- compression wave angle beam techniques;
- stainless steel calibration blocks for range setting;
- examples of reference blocks.

Requests for official interpretations of any aspect of this International Standard should be directed to the Secretariat of ISO/TC 44/SC 5 via your national standards body. A complete listing of these bodies can be found at www.iso.org.

Introduction

Welds in austenitic steel components and dissimilar metal welds are widely regarded as very difficult to inspect by ultrasound. The problems are mainly associated with unfavourable structure and grain size, as well as with different material properties which result in inhomogeneous and anisotropic mechanical and acoustic properties that contrast with the relatively homogeneous and isotropic behaviour in low-alloy steel welds.

Austenitic weld metal and other coarse-grained, anisotropic materials can significantly affect ultrasound propagation. In addition, beam distortion, unexpected reflections and wave mode conversions on the fusion line and/or columnar grains can occur. Therefore it can be difficult and sometimes impossible for ultrasonic waves to penetrate the weld metal.

Ultrasonic testing of these metals may require techniques that differ from conventional techniques. These special techniques often include the use of dual-element probes designed for refracted compression (longitudinal) waves or creeping waves rather than for conventional shear waves.

In addition, it is necessary to produce representative reference blocks with welds in order to develop a testing procedure, set a preliminary sensitivity level, assess the procedure and demonstrate effectiveness before a definitive procedure is written. Material, weld preparation and welding procedure, as well as the geometry and surface condition of reference blocks are the same as for the component being tested.

Non-destructive testing of welds — Ultrasonic testing — Testing of welds in austenitic steels and nickel-based alloys

1 Scope

This International Standard specifies the approach to be followed when developing procedures for the ultrasonic testing of the following welds:

- welds in stainless steels;
- welds in nickel-based alloys;
- welds in duplex steels;
- dissimilar metal welds;
- austenitic welds.

The purposes of the testing can be very different, e.g.:

- for the assessment of quality level (manufacturing);
- for the detection of specific indications induced in service.

Acceptance levels are not included in this International Standard, but can be applied in accordance with the scope of the testing (see Clause 5).

The requirements of this International Standard are applicable to both manual and mechanized testing.

2 Normative references

The following referenced documents are indispensable for the application of this document. For dated references, only the edition cited applies. For undated references, the latest edition of the referenced document (including any amendments) applies.

ISO 5577, *Non-destructive testing — Ultrasonic inspection — Vocabulary*

ISO 7963, *Non-destructive testing — Ultrasonic testing — Specification for calibration block No. 2*

ISO 9712, *Non-destructive testing — Qualification and certification of NDT personnel*

ISO 17635, *Non-destructive testing of welds — General rules for metallic materials*

ISO 17640, *Non-destructive testing of welds — Ultrasonic testing — Techniques, testing levels, and assessment*

EN 473, *Non-destructive testing — Qualification and certification of NDT personnel — General principles*

EN 12668-1, *Non-destructive testing — Characterization and verification of ultrasonic examination equipment — Part 1: Instruments*

EN 12668-2, *Non-destructive testing — Characterization and verification of ultrasonic examination equipment — Part 2: Probes*

EN 12668-3, *Non-destructive testing — Characterization and verification of ultrasonic examination equipment — Part 3: Combined equipment*

ISO 22825:2012(E)

3 Terms and definitions

For the purposes of this document, the terms and definitions given in ISO 5577, ISO 17635 and the following apply.

3.1
dual-element probe
ultrasonic probe in which the transmit and receive transducers are separate and are electrically and acoustically isolated from each other

3.2
focal distance
(dual element probes) distance between probe and focal point on the acoustical axis where the acoustic pressure is at its maximum

3.3
focal curve
(dual element probes) curve, representing the relationship between sound path and sensitivity of a probe on a specified material containing specified reflectors

4 Information required prior to testing

4.1 Items to be defined by specification

Information on the following items is required:

- a) material type and grade;
- b) purpose and extent of testing, including testing for transverse indications, if required;
- c) testing levels (see Clause 10);
- d) manufacturing or operation stage at which the testing shall be carried out;
- e) requirements for access, the surface condition (see 11.2) and temperature;
- f) whether or not parent metal testing shall be carried out prior to and/or after welding (see 11.3);
- g) reference blocks (see Clauses 6 and 7);
- h) personnel qualifications (see Clause 5);
- i) reporting requirements (see Clause 12);
- j) acceptance criteria and/or recording level.

4.2 Specific information required by the operator prior to testing

Before any testing of a welded joint, the operator shall have access to all the information as specified in 4.1, together with the following additional information:

- a) the written testing procedure (see Clause 9);
- b) type(s) of parent material and product form (i.e. cast, forged, rolled);
- c) the joint preparation and dimensions;
- d) the welding procedure or relevant information on the welding process;
- e) the time of the inspection with regard to any post-weld heat treatment;
- f) the result of any parent metal testing carried out prior to and/or after welding;

g) reference points and details of co-ordinate systems for the test object.

5 Personnel

Personnel performing testing in accordance with this International Standard shall be qualified to an appropriate level in accordance with ISO 9712 or EN 473 or equivalent in the relevant industrial sector.

In addition to a general knowledge of ultrasonic weld testing, the operators shall be familiar with and have practical experience in testing problems specifically associated with the type of materials and weld joints to be tested. Specific training and examination of personnel should be performed on representative pieces (duplex, austenitic, stainless steel) containing welds and using dual-element longitudinal wave probes. This training and the examination results should be documented.

If this is not the case, specific training and examination should be performed with the finalized ultrasonic testing procedures and selected ultrasonic testing equipment on representative samples containing natural or artificial reflectors similar to those expected. This training and the examination results should be documented.

6 Equipment

The equipment used for testing shall fulfil the requirements of EN 12668-1 and EN 12668-2. The verification of the combined equipment shall be done in accordance with EN 12668-3, with the exception of dual-element compression wave angle beam probes, which can be verified on appropriate reference blocks other than the blocks mentioned in EN 12668-3.

Focal curves shall be available for the dual-element probes to be used, determined on a material representative of the material to be tested.

7 Range setting for compression waves

Range setting shall be carried out on appropriate calibration blocks, e.g. on blocks which are designed to be similar to block No. 2 (see ISO 7963) as shown in Annex B. The dimension of at least one of the radii of the block used shall be close to the focal distance of the probes.

The index point of each probe shall be marked on the probe's side, after having optimized the echo amplitude on the radius closest to its focal distance. Since echo optimization can be difficult for high-angle probes and creeping wave probes, the shear wave component may be used for optimization instead. In that case, the calibration methodology shall be included in the test procedure.

Optimization of the echoes shall be done on the two radii separately, and by iteration until the signals from the smaller and the larger radius are on their correct positions.

Alternatively, the time base may be set with the aid of a single-element straight beam probe on the width of the calibration block, and subsequent zero point adjustment with the angle probe placed on the calibration block, on the radius which is closest to the probe's focal distance.

Range setting shall be carried out prior to each testing. Checks to confirm these settings shall be performed at least every 4 h and on completion of testing.

Checks shall also be carried out whenever a system parameter is changed or whenever changes in the equivalent settings are suspected.

If deviations are found during these checks, corrective actions shall be carried out as specified in Table 1.

Table 1 — Range deviations

1	Deviations ≤ 5 % of the range	No correction is needed, test can be continued
2	Deviations > 5 % of the range	The setting shall be corrected and all tests carried out over the previous period shall be repeated

ISO 22825:2012(E)

8 Sensitivity setting

8.1 General

Sensitivity setting shall be performed on a reference block with a weld. Annex C shows examples for reference blocks. The wall thickness of the reference block shall be similar to the wall thickness of the component to be tested within 10 % or 3 mm, whichever is the larger.

Reference reflectors may be side-drilled holes in the weld centre and/or on the fusion line. Alternatively, flat-bottomed holes on the fusion line may be used, having the flat bottom in the plane of the fusion line (weld bevel). Surface notches shall be used as references for near-surface defects. See Figures C.1, C.2, and C.3.

Zone coverage related to wall thickness shall be established on the basis of the focal curves as shown in A.6 when dual-element probes are used. Zone overlap shall be documented in the procedure.

Setting of sensitivity shall be carried out prior to each testing in accordance with this International Standard.

The gap, g , between test surface and bottom of the probe shoe shall not be greater than 0,5 mm.

For cylindrical or spherical surfaces, this requirement can be checked with Equation (1):

$$g = \frac{a^2}{D} \quad (1)$$

where

D is the diameter, in millimetres, of the component;

a is the dimension, in millimetres, of the probe shoe in the direction of testing.

If a value for g larger than 0,5 mm results from Equation (1), the probe shoe shall be adapted to the surface, and the sensitivity and range shall be set accordingly.

Checks to confirm these settings shall be performed at least every 4 h and on completion of testing. Checks shall also be carried out if a system parameter is changed or if changes in the equivalent settings are suspected.

If deviations are found during these checks, corrective actions shall be carried out as specified in Table 2.

Table 2 — Sensitivity deviations

1	Deviations ≤ 2 dB	No correction is needed, test can be continued
2	Deviations between 2 dB and 4 dB	The setting shall be corrected before testing is continued
3	Reduction in sensitivity > 4 dB	The setting shall be corrected and all tests carried out since the last valid test shall be repeated
4	Increase in sensitivity > 4 dB	The setting shall be corrected and all indications recorded since the last valid test shall be re-evaluated

8.2 Use of side-drilled holes

If the reflectors in the fusion line are used, sensitivity settings shall be performed:

- a) by establishing the echo height with the sound beam passing through the parent material only;
- b) by establishing the echo height with the sound beam passing through the weld metal.

If the reflectors in the weld centreline are used, sensitivity setting may be performed from one side only, with the exception of dissimilar metal welds (where the acoustic properties of the parent metal are different on one side compared to the other).

Side-drilled hole diameter shall be typically 3 mm.

8.3 Use of other reference reflectors

Where specific discontinuities are to be detected and/or in a particular limited zone of the weld, other types and dimensions of reference reflectors may be used. In that case, specific conditions of sensitivity setting shall be defined.

In pipe weld inspection, flat-bottomed holes and notches are typically used as reference reflectors. An example for a pipeline girth weld is given in Figure C.2.

The position of the flat-bottomed hole shall be determined from a macro-section of the austenitic weld, positioned accordingly in the reference block and machined to position the flat bottom at the fusion line.

9 Test procedure and ultrasonic techniques

9.1 Development of the test procedure

The development of a procedure shall follow the main steps as mentioned in the flowchart shown in Figure 1.

9.2 Content of the procedure

A procedure shall be written and shall include the following information as a minimum:

- a) the purpose and extent of testing;
- b) testing techniques;
- c) testing levels;

NOTE For the testing of austenitic steels, the testing levels are not defined in ISO 17640 as for ferritic steels. However, it is important to set them to take into account the required probability of detection in each area under consideration.

- d) personnel qualification/training requirements;
- e) equipment requirements;
- f) probe for each zone or part of the bevel;
- g) reference blocks;
- h) test blocks, if applicable;
- i) the setting of equipment;
- j) available access and surface conditions;
- k) scanning directions and probe positions;
- l) the testing of parent material;
- m) the evaluation of indications;
- n) acceptance levels and/or recording levels;
- o) reporting requirements;
- p) environmental and safety issues.

ISO 22825:2012(E)

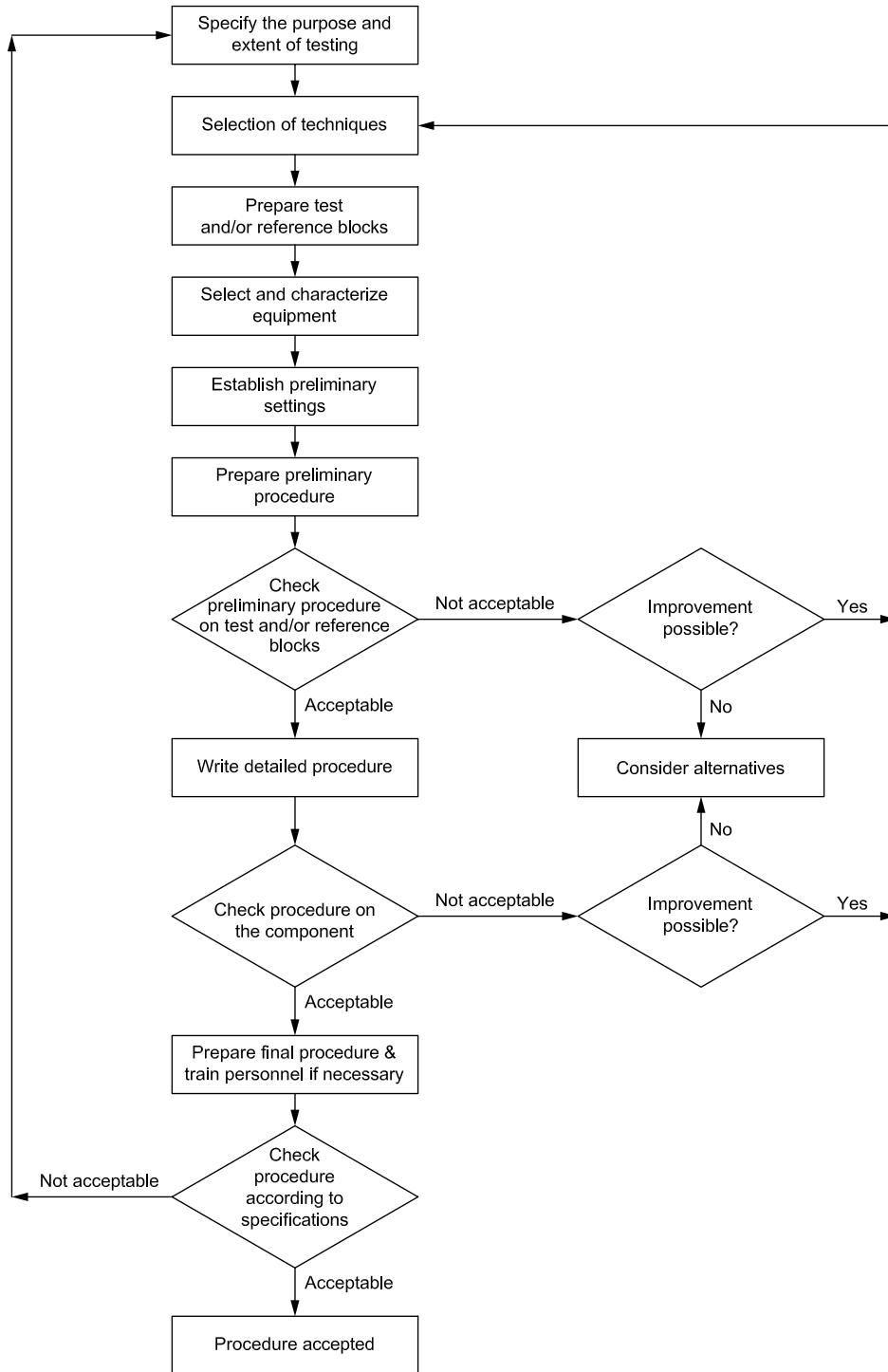

Figure 1 — Steps necessary when producing a written ultrasonic procedure

9.3 Selection of ultrasonic technique(s)

The technique(s) to be used shall be selected on the basis of initial test measurements on relevant test samples (see Annex C). Such measurements shall include transfer measurements on the parent metal (using shear waves), exploratory measurements to get an impression of the noise level in the weld (using shear and compression waves), and measurements on artificial reflectors through the weld metal (to get an impression of the achievable signal-to-noise ratios in different parts of the weld).

In any case, it shall be verified that all reference reflectors in the reference weld (including those to be detected through the weld metal) are detected with at least the minimum signal-to-noise ratio according to the specification. Dependent on the results obtained, one of the following situations can arise.

- a) The structure of the weld and the parent metal are both relatively fine grained.

This may imply that conventional ultrasonic techniques (shear wave probes) can be used. If the signal-to-noise ratio is at least 12 dB, then ISO 17640 can be applied without restrictions.

- b) The structure of the parent metal is fine grained but the structure of the weld metal is coarse.

This means that the parent metal allows unrestricted penetration of shear waves and compression waves, but shear waves have difficulty in penetrating the weld. In this case, compression waves shall be used for at least those functions used to detect reflectors in, or through, the weld metal. Shear waves may be used for detection of defects on the fusion line that do not require penetration through the weld metal. To detect imperfections in or through the weld, mode-converted waves that enable indirect insonification of reflectors may be used, e.g. TL-techniques and LLT-techniques (see Annex A).

- c) The structure of both the parent metal and the weld is coarse.

This may imply that for the penetration of both parent and weld metal, compression waves are required. In this case, only techniques using direct insonification of reflectors with compression waves shall be used. This may be the case in some duplex steel components (see Annex A).

- d) The structure of the weld and/or parent metal does not allow for ultrasonic testing with sufficient signal-to-noise ratio. In this case, other NDT methods shall be considered.

9.4 Optimization of technique and draft of procedure

Having selected the basic technique(s) for different parts (zones) of the weld, techniques shall be selected and optimized for each zone. For dual-element probes for refracted compression waves, this implies that optimum frequency, beam angle, focal distance, and element size shall be selected for each zone separately (see Annex A).

Dependent on the application and the standards applicable, techniques shall be selected in such a way that all potential defects specific to the weld type and procedure are detected. For detection of potential cold cracks, perpendicular to the surface, (round trip) tandem shall be used in addition to the direct and indirect detection functions.

Beam spread (and thus the extension of the focal curve) shall be optimized by selecting the probe with suitable element size, to ensure sufficient coverage over the full wall thickness. Amplitude dips between the focal curves of the probes used (Annex A) shall not exceed 3 dB, to ascertain detection of defects located in the boundary area between zones.

9.5 Practical implications of the use of refracted compression waves

When using compression wave probes, the weld shall, in most cases, be scanned several times, dependent on wall thickness. In these scans, probes specifically selected for different depth zones or for different parts of the weld bevel shall be used. Multiple probe arrangements may be used, enabling simultaneous scanning of multiple zones.

Manual scanning should be performed parallel at constant distance to the weld centreline (line scanning), thereby specifically observing those portions of the time base where relevant signals can be expected.

The techniques are described in Annex A.

Calibration blocks for range setting are described in Annex B.

Reference blocks for sensitivity setting are described in Annex C.

ISO 22825:2012(E)

10 Classification and sizing of indications

Classification rules for geometric, metallurgic, and discontinuity indications, and the appropriate way of registration or notation shall be addressed in the procedure.

Sizing techniques shall be specified in the procedure, e.g. length sizing by the 6 dB drop technique and height sizing by tip diffraction.

11 Testing of welds

11.1 General

Testing of the weld and heat-affected zone shall be carried out in accordance with a written procedure, according to the requirements of 9.2.

11.2 Surface condition and couplant fluid

The surface shall be free from any irregularities that may interfere with the ultrasonic testing. Waviness of the scanning surface and other local variations in surface contour shall not result in a gap between the probes and the scanning surface greater than 0,5 mm (see 8.1).

Where necessary, light grinding may be carried out to ensure a smooth surface finish.

The scanning surfaces and surfaces from which the sound beam is reflected may be assumed to be satisfactory if the surface roughness, R_a , is not greater than 6,3 μm for machined surfaces or not greater than 12,5 μm for shot-blasted surfaces.

For some applications, it may be necessary to grind the weld reinforcement flush with the parent metal. This shall be clearly stated in the procedure.

Care shall be taken not to bring carbon steel objects (manipulator parts, steel rulers) in direct contact with stainless steel surfaces, in order to avoid corrosion.

Couplant fluids shall comply with specified requirements concerning chlorides, sulfides or any other substance that might damage the material to be tested.

11.3 Parent metal testing

The parent material in the scanning zone area shall be tested with straight beam probes prior to or after welding, unless it can be demonstrated (e.g. in previous tests during the manufacturing process) that the angle beam testing of the weld is not influenced by the presence of discontinuities.

Where discontinuities in the parent metal are found, their influence on the proposed testing of the weld shall be assessed and, if necessary, the technique adjusted correspondingly. When satisfactory coverage by ultrasonic testing is seriously affected, other testing methods (e.g. radiography) shall be considered.

11.4 Scanning

Scanning shall ensure the coverage of the specified examination volume.

Scanning may be carried out in straight lines parallel to the weld centreline (line scanning).

Calculations of the relevant parts of the time base, as well as a confirmation thereof on the reference block, shall be done as a part of procedure development.

A documented examination strategy or scan plan shall be provided showing probe placement, movement, and examination coverage. This scan plan shall also include the beam angles used, beam directions with respect to weld centreline, and weld volume examined.

11.5 Evaluation of indications

After classification of all relevant indications and determination of their location and size, they should be evaluated against specified acceptance criteria and acceptance levels, respectively.

Based upon this evaluation, the indications can be categorized as “acceptable” or “not acceptable”.

NOTE Guidance on characterization of indications can be found in EN 583-5^[3] and ISO 23279^[1].

12 Test report

12.1 General data

The test report shall include, as a minimum, the following information:

- a) reference to this International Standard (ISO 22825:2012);
- b) identification of the test object;
- c) the material type, grade and product form;
- d) the dimensions;
- e) the location or identification of the weld tested;
- f) a sketch showing the geometrical configuration (if necessary);
- g) a reference to the welding procedure and stage of heat treatment (if any);
- h) the state of manufacture;
- i) the surface conditions;
- j) the temperature of the object, if outside the range 0 °C to 60 °C;
- k) contract requirements, e.g. specifications, guidelines, special agreements;
- l) the place and date of testing;
- m) identification of testing organizations and identification, certification, and signature of the operator.

12.2 Information related to equipment

The test report shall include the following information related to equipment:

- a) the manufacturer and type of the ultrasonic instrument, with identification number;
- b) manufacturer, type, nominal frequency, beam angle and focal distance of probes used with identification number;
- c) the identification of reference blocks used with a sketch;
- d) the couplant medium.

12.3 Information related to testing technique

The test report shall include the following information related to testing technique:

- a) testing level(s) and a reference to the written procedure;
- b) the extent of testing, including any restrictions;

ISO 22825:2012(E)

- c) the location of the scanning areas;
- d) reference points and details of the co-ordinate system;
- e) identification of probe positions;
- f) the time base range;
- g) the method and values used for sensitivity setting;
- h) reference levels;
- i) the result of the parent material testing;
- j) the standard for acceptance and/or recording levels;
- k) deviations from this International Standard or contract requirements;
- l) any factors which have prevented the testing from being carried out as intended.

12.4 Results of testing

The test report shall include a tabular summary (or sketches) providing the following information for recorded indications:

- a) co-ordinates of the indication with details of associated probes and corresponding probe positions;
- b) the maximum echo amplitude and information, if required, on the type and height of indication;
- c) lengths of indications;
- d) results of the evaluation in accordance with specified acceptance and/or recording levels.

Annex A (informative)

Compression wave angle beam techniques

A.1 Refracted compression waves

Figure A.1 shows the wave modes generated by a probe designed for compression waves. Because the angle of incidence is below the first critical angle, both shear waves and compression waves are generated.

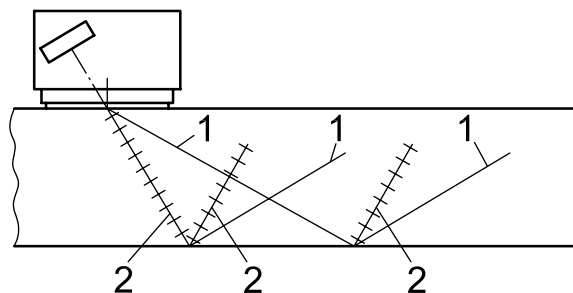

Key

- 1 compression wave
- 2 shear wave

Figure A.1 — Waves generated below the first critical angle

On reflection against the back wall, compression waves are also mode converted into shear waves. In addition, shear waves are mode converted into compression waves. The energy of these waves depends on angle, and can be calculated and represented in so-called polar diagrams (outside the scope of this International Standard).

If compression waves are used for detection, shear waves are also present as an inevitable byproduct. Although the different signals can be distinguished by their sound path (as a consequence of different sound velocities), this makes screen interpretation more complicated and requires additional operator training. It also implies that the sound path ranges in which relevant signals can be expected have to be calculated as a part of the procedure development and confirmed on the reference block.

The reception characteristic is identical to the transmission characteristic. Therefore, Figure A.1 is also valid for reception.

The most common probe frequency for weld inspection in coarse-grained, anisotropic welds is 2 MHz. However, higher (and sometimes lower) frequencies might be required, dependent on material structure.

A.2 Refracted compression waves, direct technique

Figure A.2 a) shows the situation where the compression wave is used for direct incidence on potential defects. Shear waves are also generated by wave mode conversion.

Angles can be calculated by means of Snell's law. Even if the compression wave is used to penetrate, for instance, a weld, the shear wave is also present and can (if not properly interpreted by the operator) lead to false calls or other misinterpretations.

Note that, at the point where the shear wave is reflected at the back wall, a longitudinal wave is also generated (wave mode conversion). See Figure A.1.

ISO 22825:2012(E)

Figure A.2 b) shows how the direct compression wave can be used to detect a discontinuity in a weld. The direct wave is not able to detect a discontinuity in the upper part of the weld, unless the weld reinforcement is ground flush, and the probe is placed on the weld itself.

Note that the sound path over which dual-element compression angle probes can be used is limited. The optimum range for such a probe is defined by several design parameters, such as frequency, element size and squint angle or roof angle.

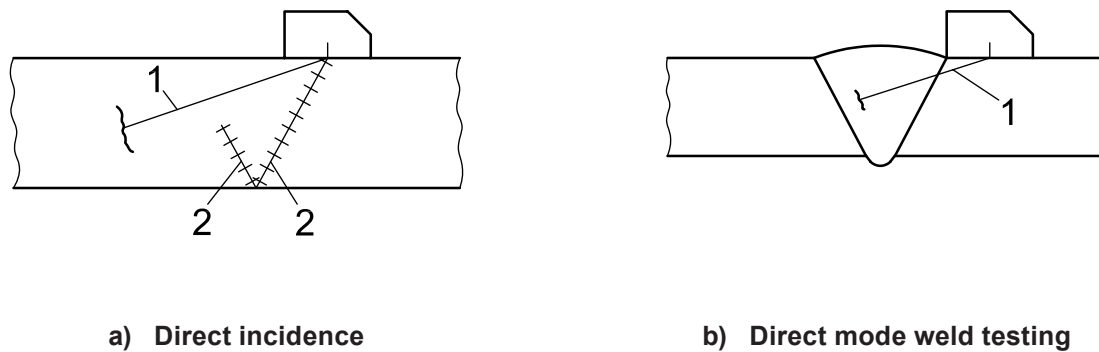

Key

- 1 compression wave
- 2 shear wave

Figure A.2 — Direct detection

A.3 Refracted compression waves with mode conversion

When compression waves are used, the indirect LL-technique using reflection at the back wall (testing over skip) is not possible. The reason is that a reflected compression wave, when it hits the back wall under an angle such as 45° to 70° , loses a lot of energy to the mode-converted shear wave.

A way to overcome this, and even to take advantage of such wave mode conversion, is to use the mode-converted compression wave generated by the traversing shear wave, TL-technique, as depicted in Figure A.3 a). This requires that the parent metal allow for unrestricted propagation of shear waves. If this approach is possible, there may be no need to grind the weld reinforcement flush, because this technique may be used as an alternative for inspection over skip. Figure A.3 b) shows how the weld can be inspected in the indirect mode.

Note that, if this indirect mode is used, the direct compression wave generated by the probe at the scanning surface (Figure A.1) is also present, and can (if not properly interpreted by the operator) lead to false calls or other misinterpretations.

A.4 Refracted compression waves, tandem and round trip tandem technique

Whereas, in shear wave testing, it is known that defects perpendicular to the surface can be detected by means of a tandem technique, this is not possible when compression waves alone are used.

However, by using the principle of A.3, it is possible to apply a tandem technique as shown in Figure A.4 a). In this technique, wave mode conversion is used. This technique may be used for the detection of perpendicular cracks such as cold cracks in the weld centre or lack of fusion defects at steep bevel angles. Varying the distance between the probes is a way of varying the depth position where the beams intersect (and thus the depth zone at which the highest sensitivity is present).

If the transmitter and the receiver coincide [Figure A.4 b)], the depth zone for which the technique is optimized is fixed (optimum depth is ~0,6 times the wall thickness). This technique is usually called “round trip tandem” and is most often used for detection of perpendicular defects in coarse-grained, anisotropic welds.

NOTE 1 The ultrasonic waves propagate both ways at the same time: compression–compression–shear and shear–compression–compression. This is because transmitter and receiver elements are identical and both are capable of transmitting and receiving compression and shear waves.

NOTE 2 For round trip tandem, the same types of probes can be used as for direct and indirect incidence as described in A.2 and A.3. This means that the same reflector, dependent on its reflection characteristics, may be detected with different modes at the same time (direct, indirect, round trip tandem). This is especially the case for reflectors such as side-drilled holes. The signals can be distinguished by their sound path.

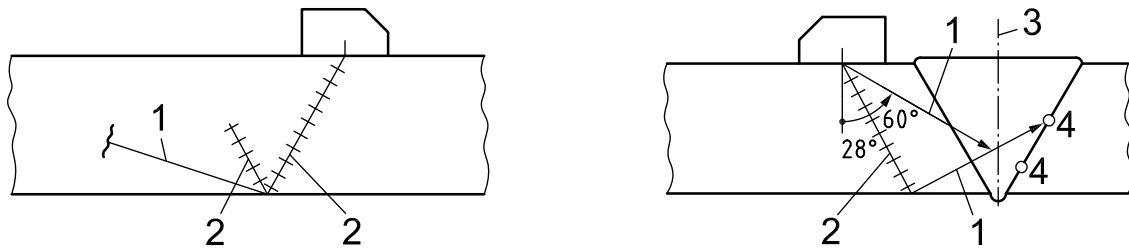

a) Indirect incidence (mode conversion)

b) Indirect mode weld testing

Key

- 1 compression waves
- 2 shear waves
- 3 centreline
- 4 reflectors

Figure A.3 — Indirect detection

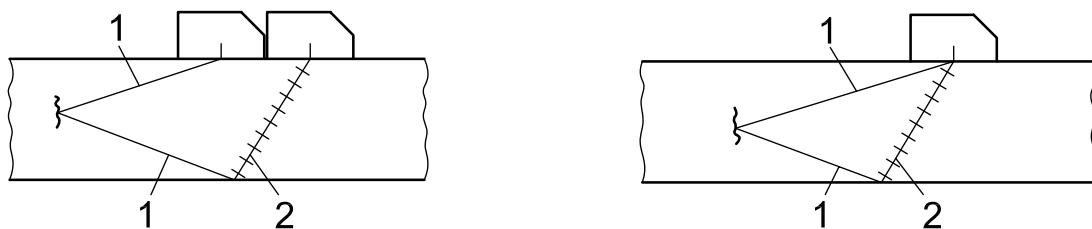

a) Tandem technique with mode conversion

b) Round trip tandem technique

Key

- 1 compression wave
- 2 shear wave

Figure A.4 — Tandem techniques

A.5 Creeping wave technique

A special case of refracted compression waves are creeping waves. Creeping waves are able to detect surface and near-surface defects with high sensitivity, even through coarse-grained, anisotropic welds.

Creeping waves propagate close to the scanning surface, and are generated by probes designed for compression waves with beam angles close to 90°. Creeping waves have sound velocities equal to those of

ISO 22825:2012(E)

compression waves and propagate at a depth of approximately one wavelength below the scanning surface. Creeping waves do not follow curved surfaces.

Creeping waves are associated with a high-angle compression wave lobe (75° to 80°), which enables the detection of not only surface breaking, but also near-surface defects up to a depth of typically 5 mm to 15 mm, dependent on probe characteristics.

NOTE Creeping waves are fundamentally different from surface waves or Rayleigh waves; the latter can be considered as asymmetric (shear) surface waves, propagating at the scanning surface, and having a sound velocity of approximately 0,9 times the shear wave velocity. Surface waves tend to follow curved surfaces.

Creeping waves continuously generate shear waves (also called head waves), as a consequence of interaction with the surface [Figure A.5 a)]. These head waves are able to generate a secondary creeping wave at the back wall, which can be used to detect surface or near-surface defects at the back wall [Figure A.5 b)].

The fact that creeping waves continuously generate shear waves or head waves during their propagation along the surface is also the reason that they suffer from a relatively high attenuation. Therefore, creeping waves cannot be used over large distances.

Figure A.5 c) shows, as an example, the typical signals of a surface (A) and a back wall (B) notch, detected with primary and secondary creeping waves in a 50 mm thick duplex stainless steel weld.

A.6 Through-wall coverage

Since dual-element angle beam probes for compression waves have their optimum sensitivity at a specified depth, more than one probe is required to ensure full coverage of the entire wall thickness.

Figure A.6 shows how the individual focal curves of a number of different probes combined provide full coverage of (in this example) a 100 mm thick weld. Note that, in the example, only direct techniques are used, and creeping waves for the near-scanning surface zone. The same principle is nonetheless valid for indirect techniques.

Ensuring full coverage requires that the focal curves of the individual probes be plotted as a part of probe characterization.

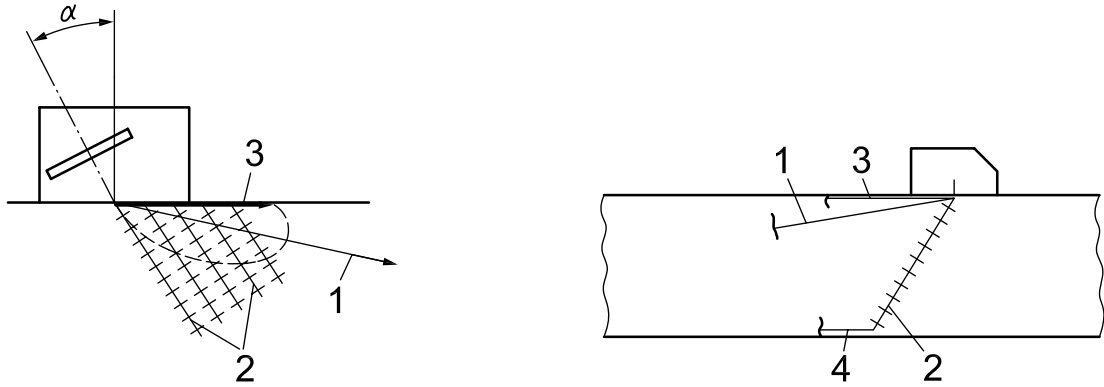

a) Generation of creeping waves

b) Primary and secondary creeping waves

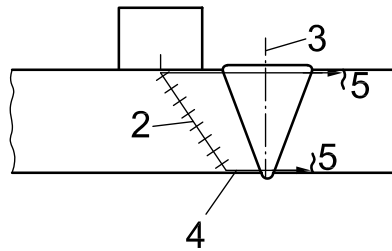
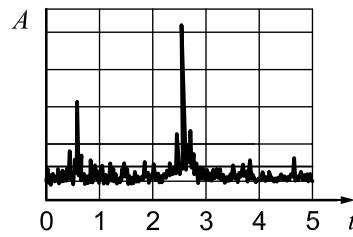

c) Application of primary and secondary creeping waves

Key

- A* amplitude
- t* time
- α angle
- 1 compression waves
- 2 shear waves
- 3 primary creeping wave
- 4 secondary creeping wave
- 5 reflector

Figure A.5 — Creeping waves

ISO 22825:2012(E)

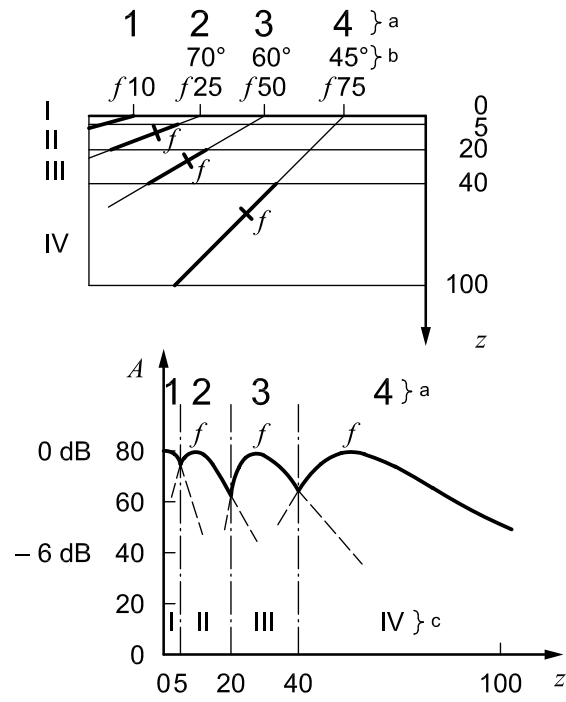

Key

- A* amplitude
- z* depth
- f* focal distances
- a Probe.
- b Creep.
- c Zone.

Figure A.6 — Through-wall coverage

Annex B (informative)

Stainless steel calibration blocks for range setting

Figure B.1 shows a sketch of a calibration block for range setting for angle beam probes for testing of austenitic steel welds.

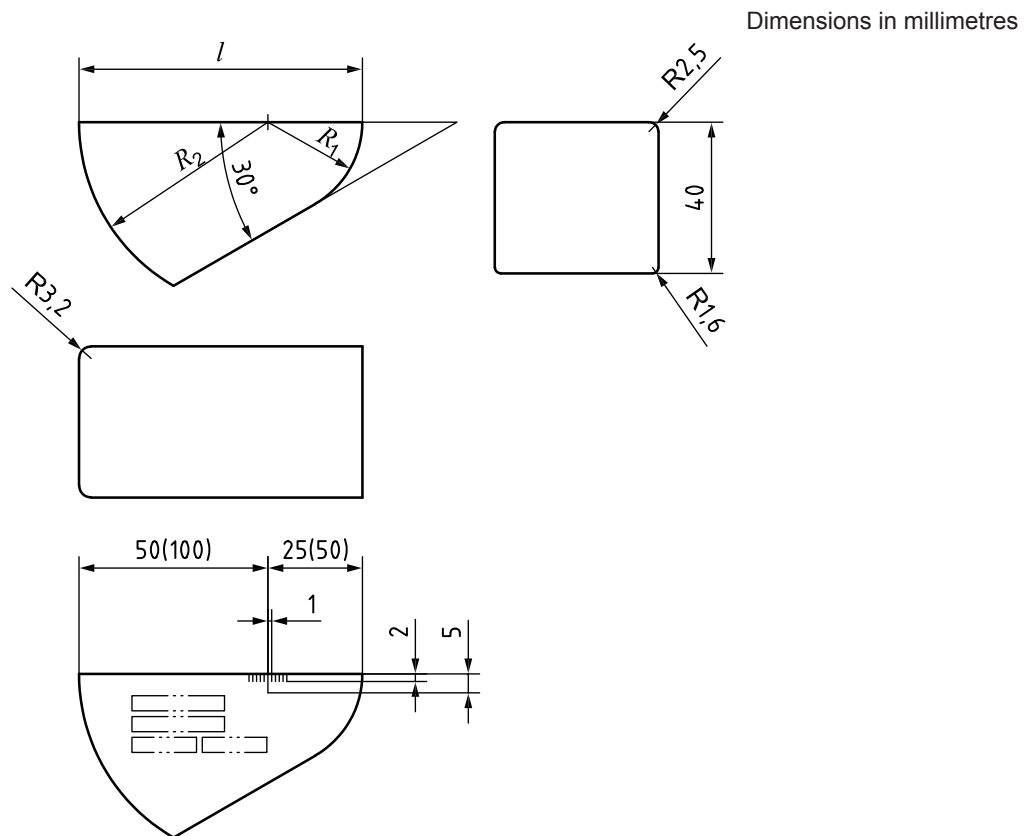

Key

- l length
- R_1 radius 1
- R_2 radius 2

Figure B.1 — Stainless steel calibration blocks

Figure B.2 shows two blocks with radii 25 mm and 50 mm or 50 mm and 100 mm made from stainless steel type AISI 304 as described in ASTM A240/A240M:2011a^[6]; material No. 1.4301, X5CrNi18-10 as described in EN 10028-7:2007^[4].

ISO 22825:2012(E)

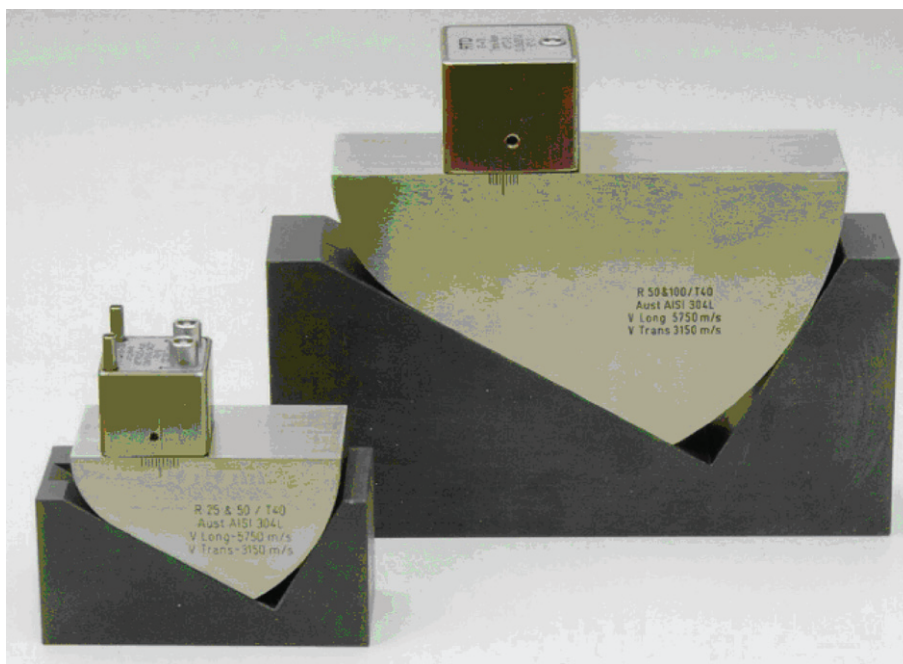

Figure B.2 — Stainless steel calibration blocks with probes

Annex C **(informative)**

Reference blocks for sensitivity setting

C.1 Representative reference blocks

Reference blocks for sensitivity setting should contain a weld and be representative in terms of wall thickness, material, welding procedure, weld shape and structure, and surface condition. It should be noted that parameters such as heat input, deposition rate and the number of weld runs have a great impact on the ultrasonic properties of welds.

Reference reflectors may be side-drilled holes or flat-bottomed holes, dependent on application. Surface notches to represent surface defects are used at the scanning and opposite surface. These may be rectangular notches or notches with their reflection side in the local plane of the weld bevel, with a length of at least 25 mm.

C.2 Use of reference blocks

Once a representative reference block is available it may be subsequently used for the following purposes:

- a) to explore noise level in parent metal and weld (this can be done prior to machining of artificial reflectors);
- b) to see if there are any spurious signals (caused by, for example, beam distortions and unexpected reflections and wave mode conversions on the fusion line and/or columnar grains);
- c) after having machined artificial reflectors, to evaluate their detectability;
- d) optimization of the probe set for each zone or bevel part and procedure development;
- e) procedure qualification, if applicable;
- f) calibration on-site.

NOTE More than one reference block can prove necessary.

C.3 Reference block lay-out

C.3.1 Blocks with side-drilled holes and notches

To avoid interference of signals from adjacent holes because of beam spread, it is recommended that holes in adjacent zones not be machined at the same end face of the block. See Figure C.1 for an example.

The length of side-drilled holes should be at least the probe width minus 5 mm, with a minimum of 25 mm.

Notches should have lengths of at least 25 mm.

ISO 22825:2012(E)

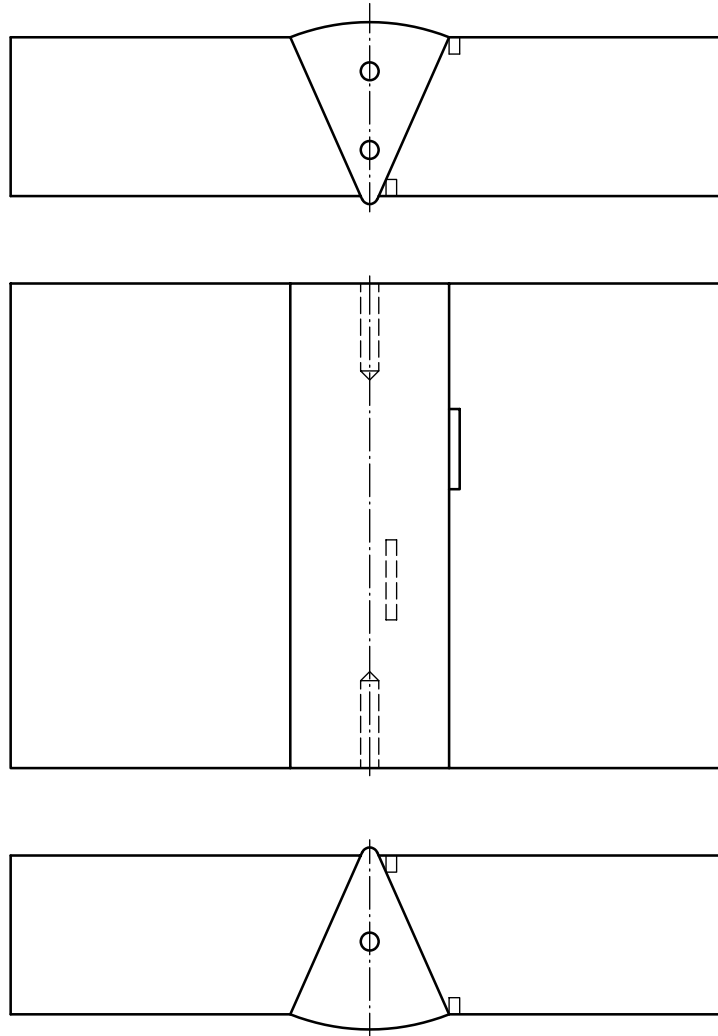
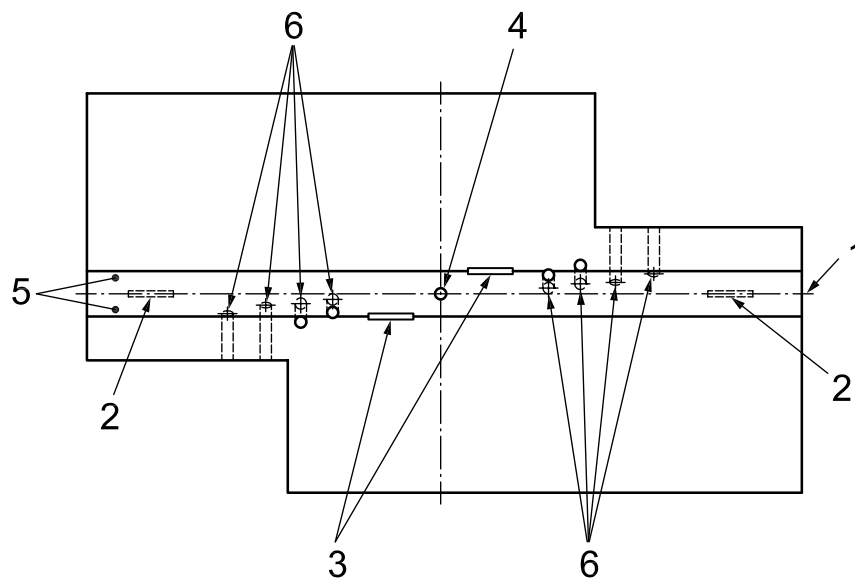

Figure C.1 — Reference block with side-drilled holes and notches

C.3.2 Blocks with flat-bottomed holes and notches

Examples of possible lay-outs of blocks with flat-bottomed holes and notches are shown in Figure C.2.

Generally direct detection is preferred [see Figure C.3 a)]. If this is not possible, e.g. because of the presence of the weld cap, indirect detection may be considered [see Figure C.3 b)]. Coverage of the entire weld volume should be confirmed by using additional reflectors in the weld. Removal of the cap may be necessary if neither of the techniques is successful.



Key

- 1 weld centreline
- 2 inside notches
- 3 outside notches
- 4 through hole
- 5 weld
- 6 flat-bottomed holes

Figure C.2 — Reference block containing a weld with flat-bottomed holes and notches

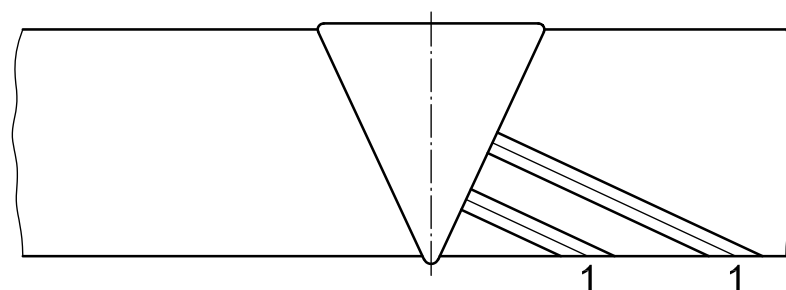

a) Flat-bottomed holes for direct detection through the weld

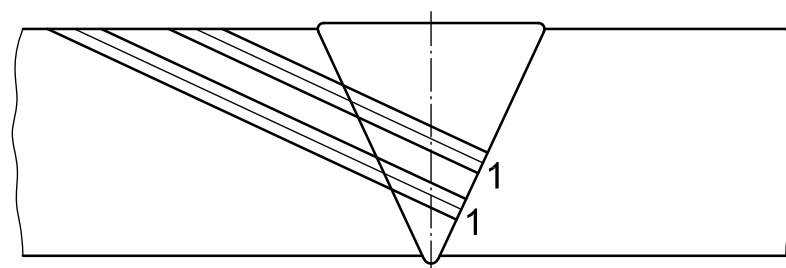

b) Flat-bottomed holes for indirect detection

Key

- 1 flat-bottomed holes

Figure C.3 — Examples of flat-bottomed holes in reference blocks

Bibliography

- [1] ISO 23279, *Non-destructive testing of welds — Ultrasonic testing — Characterization of indications in welds*
- [2] EN 583-2, *Non-destructive testing — Ultrasonic examination — Part 2: Sensitivity and range setting*
- [3] EN 583-5, *Non-destructive testing — Ultrasonic examination — Part 5: Characterization and sizing of discontinuities*
- [4] EN 10028-7:2007, *Flat products made of steels for pressure purposes — Part 7: Stainless steels*
- [5] IIW COMMISSION V. *Ultrasonic examination of austenitic and dissimilar welds — IIW handbook*. Düsseldorf: DVS Media, 2008
- [6] ASTM A240/A240M:2011a, *Standard Specification for Chromium and Chromium-Nickel Stainless Steel Plate, Sheet, and Strip for Pressure Vessels and for General Applications*

ISO 22825:2012(E)

ICS 25.160.40

Price based on 22 pages