**Hydrogen generators using water
electrolysis process —**

**Part 2:
Residential applications**

*Générateurs d'hydrogène utilisant le procédé d'électrolyse de l'eau —
Partie 2: Applications résidentielles*



Reference number
ISO 22734-2:2011(E)

© ISO 2011



COPYRIGHT PROTECTED DOCUMENT

© ISO 2011

All rights reserved. Unless otherwise specified, no part of this publication may be reproduced or utilized in any form or by any means, electronic or mechanical, including photocopying and microfilm, without permission in writing from either ISO at the address below or ISO's member body in the country of the requester.

ISO copyright office
Case postale 56 • CH-1211 Geneva 20
Tel. + 41 22 749 01 11
Fax + 41 22 749 09 47
E-mail copyright@iso.org
Web www.iso.org

Published in Switzerland

Contents

Page

Foreword	v
Introduction	vi
1 Scope	1
2 Normative references	1
3 Terms and definitions	5
4 Operating conditions	6
4.1 Energy consumption	6
4.2 Feed water specifications	6
4.3 Ambient environment	7
4.4 Purge gas	7
4.5 Oxygen venting	7
4.6 Hydrogen venting	7
4.7 Delivery of hydrogen	8
5 Mechanical equipment	8
5.1 General requirements	8
5.2 General materials requirements	9
5.3 Enclosures	9
5.4 Pressure-bearing components	11
5.5 Fans and ventilators	13
5.6 Pumps	13
5.7 Heat transfer system	13
5.8 Connection to potable water	14
6 Electrical equipment, wiring and ventilation	14
6.1 Fire and explosion hazard protection requirements	14
6.2 Electrical equipment	16
7 Control systems	18
7.1 General	18
7.2 Control function in the event of failure	19
7.3 Programmable electronic equipment	19
7.4 Start	19
7.5 Emergency stop	19
7.6 Stop	20
7.7 Self-correctable conditions	20
7.8 Interconnected installations	20
7.9 Safety components	20
7.10 Remote control systems	21
7.11 Alarms	21
7.12 Purge gas quantity	21
7.13 Reset	21
7.14 Suspension of safeguards	21
8 Ion transport medium	21
8.1 Electrolyte	21
8.2 Membrane	22
9 Protection of service personnel	22
10 Test methods	23
10.1 Type (qualification) tests	23
10.2 Routine tests	33
11 Marking and labelling	34
11.1 General requirements	34
11.2 Hydrogen generator marking	34

11.3	Marking of components	35
11.4	Warning signs	35
12	Documentation accompanying the hydrogen generator	35
12.1	General	35
12.2	Hydrogen generator ratings	36
12.3	Hydrogen generator installation	36
12.4	Hydrogen generator operation	38
12.5	Hydrogen generator maintenance	39
Annex A	(informative) Hydrogen-assisted corrosion	40
Annex B	(informative) Flammability limits of hydrogen	41
Bibliography	42

.....

Foreword

ISO (the International Organization for Standardization) is a worldwide federation of national standards bodies (ISO member bodies). The work of preparing International Standards is normally carried out through ISO technical committees. Each member body interested in a subject for which a technical committee has been established has the right to be represented on that committee. International organizations, governmental and non-governmental, in liaison with ISO, also take part in the work. ISO collaborates closely with the International Electrotechnical Commission (IEC) on all matters of electrotechnical standardization.

International Standards are drafted in accordance with the rules given in the ISO/IEC Directives, Part 2.

The main task of technical committees is to prepare International Standards. Draft International Standards adopted by the technical committees are circulated to the member bodies for voting. Publication as an International Standard requires approval by at least 75 % of the member bodies casting a vote.

Attention is drawn to the possibility that some of the elements of this document may be the subject of patent rights. ISO shall not be held responsible for identifying any or all such patent rights.

ISO 22734-2 was prepared by Technical Committee ISO/TC 197, *Hydrogen technologies*.

ISO 22734 consists of the following parts, under the general title *Hydrogen generators using water electrolysis process*:

- *Part 1: Industrial and commercial applications*
- *Part 2: Residential applications*

Introduction

The technology in this part of ISO 22734 is as follows.

In a hydrogen generator cell, electricity causes dissociation of water into hydrogen and oxygen molecules. An electric current is passed between two electrodes separated by a conductive electrolyte or “ion transport medium”, producing hydrogen at the negative electrode (cathode) and oxygen at the positive electrode (anode). As water is H₂O, twice the volume of hydrogen is produced compared with oxygen.

Hydrogen gas produced using electrolysis technology can be utilized immediately or stored for later use.

The cell(s), and electrical, gas processing, ventilation, cooling, monitoring equipment and controls are contained within an enclosure. Gas compression and feed water conditioning and auxiliary equipment may also be included.

Hydrogen generators using water electrolysis process —

Part 2: Residential applications

1 Scope

This part of ISO 22734 defines the construction, safety and performance requirements of packaged hydrogen gas generation appliances, herein referred to as hydrogen generators, using electrochemical reactions to electrolyse water to produce hydrogen.

This part of ISO 22734 is applicable to hydrogen generators that use the following types of ion transport medium:

- group of aqueous bases;
- solid polymeric materials with acidic function group additions, such as acid proton exchange membrane (PEM).

This part of ISO 22734 is applicable to hydrogen generators intended for indoor and outdoor residential use in sheltered areas, such as car-ports, garages, utility rooms and similar areas of a residence. This part of ISO 22734 includes cord-connected equipment for outdoor and garage use only.

Portable generators as well as hydrogen generators that can also be used to generate electricity, such as reversible fuel cells, are excluded from the scope of this part of ISO 22734.

Hydrogen generators that also supply oxygen as a product are excluded from the scope of this part of ISO 22734.

This part of ISO 22734 is intended to be used for certification purposes.

2 Normative references

The following referenced documents are indispensable for the application of this document.

For dated

references, only the edition cited applies. For undated references, the latest edition of the referenced

document (including any amendments) applies..

ISO 1182, *Reaction to fire tests for products — Non-combustibility test*

ISO 3746, *Acoustics — Determination of sound power levels and sound energy levels of noise sources using sound pressure — Survey method using an enveloping measurement surface over a reflecting plane*

ISO 3864-2, *Graphical symbols — Safety colours and safety signs — Part 2: Design principles for product safety labels*

ISO 4126-1, *Safety devices for protection against excessive pressure — Part 1: Safety valves*

ISO 4126-2, *Safety devices for protection against excessive pressure — Part 2: Bursting disc safety devices*

ISO 4126-6, *Safety devices for protection against excessive pressure — Part 6: Application, selection and installation of bursting disc safety devices*

ISO 7000, *Graphical symbols for use on equipment — Index and synopsis*

ISO 22734-2:2011(E)

ISO 7010, *Graphical symbols — Safety colours and safety signs — Registered safety signs*

ISO 7866, *Gas cylinders — Refillable seamless aluminium alloy gas cylinders — Design, construction and testing*

ISO 9300, *Measurement of gas flow by means of critical flow Venturi nozzles*

ISO 9951, *Measurement of gas flow in closed conduits — Turbine meters*

ISO 9614-1, *Acoustics — Determination of sound power levels of noise sources using sound intensity — Part 1: Measurement at discrete points*

ISO 9809-1, *Gas cylinders — Refillable seamless steel gas cylinders — Design, construction and testing — Part 1: Quenched and tempered steel cylinders with tensile strength less than 1 100 MPa*

ISO 10286, *Gas cylinders — Terminology*

ISO 10790, *Measurement of fluid flow in closed conduits — Guidance to the selection, installation and use of Coriolis meters (mass flow, density and volume flow measurements)*

ISO 11119-1, *Gas cylinders of composite construction — Specification and test methods — Part 1: Hoop wrapped composite gas cylinders and tubes*

ISO 11119-2, *Gas cylinders of composite construction — Specification and test methods — Part 2: Fully wrapped fibre reinforced composite gas cylinders with load-sharing metal liners*

ISO 11119-3, *Gas cylinders of composite construction — Specification and test methods — Part 3: Fully wrapped fibre reinforced composite gas cylinders and tubes with non-metallic and non-load-sharing metal liners*

ISO 12100, *Safety of machinery — General principles for design — Risk assessment and risk reduction*

ISO 12499, *Industrial fans — Mechanical safety of fans — Guarding*

ISO 13709, *Centrifugal pumps for petroleum, petrochemical and natural gas industries*

ISO 13850, *Safety of machinery — Emergency stop — Principles for design*

ISO 13854, *Safety of machinery — Minimum gaps to avoid crushing of parts of the human body*

ISO 13857, *Safety of machinery — Safety distances to prevent hazard zones being reached by upper and lower limbs*

ISO 14511, *Measurement of fluid flow in closed conduits — Thermal mass flowmeters*

ISO 14687 (all parts), *Hydrogen fuel — Product specification*

ISO 14847, *Rotary positive displacement pumps — Technical requirements*

ISO 15534-1, *Ergonomic design for the safety of machinery — Part 1: Principles for determining the dimensions required for openings for whole-body access into machinery*

ISO 15534-2, *Ergonomic design for the safety of machinery — Part 2: Principles for determining the dimensions required for access openings*

ISO 15649, *Petroleum and natural gas industries — Piping*

ISO/TR 15916, *Basic considerations for the safety of hydrogen systems*

ISO 16111, *Transportable gas storage devices — Hydrogen absorbed in reversible metal hydride*

ISO 16528-1, *Boilers and pressure vessels — Performance requirements*

ISO 17398, *Safety colours and safety signs — Classification, performance and durability of safety signs*

- ISO 22734-1, *Hydrogen generators using water electrolysis process — Part 1: Industrial and commercial applications*
- ISO 26142, *Hydrogen detection apparatus — Stationary applications*
- IEC 60034-1, *Rotating electrical machines — Part 1: Rating and performance*
- IEC 60068-2-18:2010, *Environmental Testing — Part 2-18: Tests — Test R and Guidance: Water*
- IEC 60079-0, *Explosive atmospheres — Part 0: Equipment — General requirements*
- IEC 60079-2:2007, *Explosive atmospheres — Part 2: Equipment protection by pressurized enclosures “p”*
- IEC 60079-10-1, *Explosive atmospheres — Part 10-1: Classification of areas — Explosive gas atmospheres*
- IEC 60079-29-2, *Explosive atmospheres — Part 29-2: Gas detectors — Selection, installation, use and maintenance of detectors for flammable gases and oxygen*
- IEC 60079-30-1, *Explosive atmospheres — Part 30-1: Electrical resistance trace heating — General and testing requirements*
- IEC 60146 (all parts), *Semiconductor converters*
- IEC 60204-1:2005, *Safety of machinery — Electrical equipment of machines — Part 1: General requirements*
- IEC/TR 60269-5, *Low-voltage fuses — Part 5: Guidance for the application of low-voltage fuses*
- IEC 60335-1:2010, *Household and similar electrical appliances — Safety — Part 1: General requirements*
- IEC 60335-2-41, *Household and similar electrical appliances — Safety — Part 2-41: Particular requirements for pumps*
- IEC 60335-2-51, *Household and similar electrical appliances — Safety — Part 2-51: Particular requirements for stationary circulation pumps for heating and service water installations*
- IEC 60335-2-80, *Household and similar electrical appliances — Safety — Part 2-80: Particular requirements for fans*
- IEC 60364-4-43, *Low-voltage electrical installations — Part 4-43: Protection for safety — Protection against overcurrent*
- IEC 60364-6:2006, *Low-voltage electrical installations — Part 6: Verification*
- IEC 60417, *Graphical symbols for use on equipment*
- IEC 60439-1, *Low-voltage switchgear and controlgear assemblies — Part 1: Type-tested and partially type-tested assemblies*
- IEC 60439-2, *Low-voltage switchgear and controlgear assemblies — Part 2: Particular requirements for busbar trunking systems (busways)*
- IEC 60439-3, *Low-voltage switchgear and controlgear assemblies — Part 3: Particular requirements for low-voltage switchgear and controlgear assemblies intended to be installed in places where unskilled persons have access for their use — Distribution boards*
- IEC 60439-5, *Low-voltage switchgear and controlgear assemblies — Part 5: Particular requirements for assemblies for power distribution in public networks*
- IEC 60445, *Basic and safety principles for man-machine interface, marking and identification — Identification of equipment terminals, conductor terminations and conductors*
- IEC 60364-6:2006, *Low-voltage electrical installations — Part 6: Verification*
- IEC 60529, *Degrees of protection provided by enclosures (IP Codes)*

ISO 22734-2:2011(E)

IEC 60534 (all parts), *Industrial-process control valves*

IEC 60695-11-10, *Fire hazard testing — Part 11-10: Test flames — 50 W horizontal and vertical flame test methods*

IEC 60695-11-20, *Fire hazard testing — Part 11-20: Test flames — 500 W Flame test methods*

IEC 60730-1:2010, *Automatic electrical controls for household and similar use — Part 1: General requirements*

IEC 60747 (all parts), *Semiconductor devices — Discrete devices*

IEC/TR 60877, *Procedures for ensuring the cleanliness of industrial-process measurement and control equipment in oxygen service*

IEC 60947-2, *Low-voltage switchgear and controlgear — Part 2: Circuit-breakers*

IEC 60947-3, *Low-voltage switchgear and controlgear — Part 3: Switches, disconnectors, switch-disconnectors and fuse-combination units*

IEC 60947-4-1, *Low-voltage switchgear and controlgear — Part 4-1: Contactors and motor-starters — Electromechanical contactors and motor-starters*

IEC 60947-4-2, *Low-voltage switchgear and controlgear — Part 4-2: Contactors and motor-starters — AC semiconductor motor controllers and starters*

IEC 60947-4-3, *Low-voltage switchgear and controlgear — Part 4-3: Contactors and motor-starters — AC semiconductor controllers and contactors for non-motor loads*

IEC 60947-5-1, *Low-voltage switchgear and controlgear — Part 5-1: Control circuit devices and switching elements — Electromechanical control circuit devices*

IEC 60947-5-2, *Low-voltage switchgear and controlgear — Part 5-2: Control circuit devices and switching elements — Proximity switches*

IEC 60947-5-3, *Low-voltage switchgear and controlgear — Part 5-3: Control circuit devices and switching elements — Requirements for proximity devices with defined behaviour under fault conditions*

IEC 60947-5-5, *Low-voltage switchgear and controlgear — Part 5-5: Control circuit devices and switching elements — Electrical emergency stop device with mechanical latching function*

IEC 60947-6-1, *Low-voltage switchgear and controlgear — Part 6-1: Multiple function equipment — Transfer switching equipment*

IEC 60947-6-2, *Low-voltage switchgear and controlgear — Part 6-2: Multiple function equipment — Control and protective switching devices (or equipment)*

IEC 60947-7-1, *Low-voltage switchgear and controlgear — Part 7-1: Ancillary equipment — Terminal blocks for copper conductors*

IEC 60947-7-2, *Low-voltage switchgear and controlgear — Part 7-2: Ancillary equipment — Protective conductor terminal blocks for copper conductors*

IEC 60950-1:2005, *Information technology equipment — Safety — Part 1: General requirements*

IEC 61000 (applicable parts), *Electromagnetic compatibility (EMC)*

IEC 61010-1:2010, *Safety requirements for electrical equipment for measurement, control, and laboratory use — Part 1: General requirements*

IEC 61069-7, *Industrial-process measurement and control — Evaluation of system properties for the purpose of system assessment — Part 7: Assessment of system safety*

IEC 61131-1, *Programmable controllers — Part 1: General information*

IEC 61131-2, *Programmable controllers — Part 2: Equipment requirements and tests*

IEC 61204-1, *Low-Voltage Power Supply Devices, D.C. Output — Part 1: Performance Characteristics*

IEC 61508, *Functional safety of electrical/electronic/programmable electronic safety-related systems*

IEC 61511-1, *Functional safety: Safety instrumented systems for the process industry sector — Part 1: Framework, definitions, system, hardware and software requirements*

IEC 61558-1, *Safety of power transformers, power supplies, reactors and similar products — Part 1: General requirements and tests*

IEC 61558-2-17, *Safety of power transformers, power supply units and similar — Part 2-17: Particular requirements for transformers for switch mode power supplies*

IEC 61672-1, *Electroacoustics — Sound level meters — Part 1: Specifications*

IEC 61672-2, *Electroacoustics — Sound level meters — Part 2: Pattern evaluation tests*

3 Terms and definitions

For the purposes of this document, the terms and definitions given in ISO 22734-1 and the following apply.

3.1

accessible part

part or surface that can be touched by means of test probe B of IEC 61032, and if the part or surface is made of metal, any conductive part connected to it

3.2

all-pole disconnection

disconnection of all supply conductors by a single initiating action

NOTE For three-phase hydrogen generators, the neutral conductor is not considered to be a supply conductor.

3.3

built-in hydrogen generator

fixed hydrogen generator intended to be installed in a cabinet, in a prepared recess in a wall or in a similar location

3.4

fixed hydrogen generator

hydrogen generator that is intended to be used while fastened to a support or while secured in a specific location

NOTE Adhesives are not recognized as a means for fastening a fixed hydrogen generator to a support.

3.5

hazard

potential source of harm

3.6

mechanical ventilation

replacement of air inside an enclosure with fresh air accomplished by a mechanical device (such as a fan) to prevent or eliminate hazardous concentrations of hydrogen

3.7

natural ventilation

replacement of air inside an enclosure with fresh air accomplished exclusively by a natural draft caused, for example, by the effects of wind, temperature gradients or buoyancy effects, to prevent or eliminate hazardous concentrations of hydrogen

3.8

normal condition

condition in which all means for protection against hazards are intact

3.9

normal use

operation, including stand-by, according to the instructions for use or for the obvious intended purpose

NOTE In most cases, normal use also implies normal condition, because the instructions for use will warn against using the hydrogen generator when it is not in normal condition.

3.10

permanently connected

electrically connected to a supply by means of a permanent connection, which can be detached only by the use of a tool

3.11

portable hydrogen generator

hydrogen generator that is intended to be moved while in operation or a hydrogen generator other than a fixed hydrogen generator having a mass less than 18 kg

3.12

residential

relating to the use of hydrogen generators by laymen in private households (non-commercial and non-industrial use)

3.13

single fault condition

condition in which one means for protection against hazard is defective or one fault is present which could cause a hazard

NOTE If a single fault condition results unavoidably in another single fault condition, the two failures are considered as one single fault condition.

3.14

supply cord

flexible cord, for supply purposes, that is fixed to the hydrogen generator

3.15

tool

external device, including keys and coins, used to aid a person to perform a mechanical function

4 Operating conditions

4.1 Energy consumption

4.1.1 Electrical

The manufacturer shall specify, as outlined in IEC 60204-1, the electrical input rating for the hydrogen generator in volts, amps or watts (W or VA) and hertz.

4.1.2 Other utilities

The manufacturer shall specify any other utilities required.

4.2 Feed water specifications

The manufacturer shall define the specifications for the feed water to be used in the hydrogen generator.

4.3 Ambient environment

The manufacturer shall specify the physical environment conditions for which the hydrogen generator is designed. These shall include indoor or outdoor operation, the ambient temperature range, and the barometric and humidity specifications.

4.4 Purge gas

Where the use of purge gas is required, the manufacturer shall specify the type of purge gas and its specifications.

4.5 Oxygen venting

4.5.1 General

The manufacturer shall specify if oxygen is to be vented indoors or outdoors. If oxygen is to be vented indoors, the manufacturer shall specify if oxygen is to be vented directly out of the enclosure or within the enclosure.

4.5.2 Oxygen vented indoors

If oxygen is vented indoors, it shall not be vented directly through tubing from the enclosure in a way that could allow the oxygen to be collected.

To preclude the formation of a hazardous enriched-oxygen atmosphere within the enclosure, oxygen purposely vented inside the enclosure shall be diluted to a volume fraction of oxygen in air of less than 23,5 % before being exhausted from the enclosure by a ventilation air stream. Classified electrical equipment that could come in contact with enriched-oxygen mixtures shall be evaluated for suitability under the possible conditions (see also 6.1.3 and 6.2.1).

The design of the ventilation shall dilute the oxygen concentration such that any gas flow exiting the enclosure to the surrounding environment will not create a hazardous condition. Where mechanical ventilation is used to dilute oxygen levels, means of detecting insufficient air ventilation shall be provided and cause the hydrogen generator to shut down.

In addition, the room to which the hydrogen generator ventilates its air/gas mixture shall be sufficiently ventilated to dilute the oxygen concentration in air below a volume fraction of 23,5 %. Room ventilation requirements shall be provided in the installation instructions as required by 12.3.3 and a label warning about the presence of oxygen and hydrogen shall be affixed as required by 11.4.

NOTE Pressure-relief devices that vent indoors are to be considered when determining ventilation requirements.

4.5.3 Oxygen vented outdoors

If oxygen is vented outdoors, it shall be vented out of the enclosure to an outdoor location in a way that will not create a hazardous condition. The installation instructions shall provide full details describing acceptable methods as required by 12.3.3.

4.6 Hydrogen venting

4.6.1 General

Hydrogen shall be vented in a manner that will not create a hazardous condition in accordance with 4.6.2 and 4.6.3.

4.6.2 Hydrogen vented outdoors

Means shall be provided to connect a vent line to the hydrogen generator. Vent lines may be designed according to ISO/TR 15916, or other similar standards.

4.6.3 Hydrogen vented indoors

Hydrogen gas may be vented indoors if it is diluted to a volume fraction of hydrogen in air of less than 1 % before exiting the enclosure.

In addition, the room to which the generator ventilates its air/gas mixture shall be sufficiently ventilated to preclude formation of a hydrogen-air mixture exceeding a volume fraction of 1 % except in dilution volume. Room ventilation requirements shall be provided in the manual as required by 12.3.3 and a label warning about the presence of hydrogen shall be affixed as required by 11.4.

4.7 Delivery of hydrogen

The manufacturer shall specify the hydrogen production rate, the hydrogen output pressure, temperature, and the quality of the hydrogen produced by the hydrogen generator as in ISO 14687.

5 Mechanical equipment

5.1 General requirements

All hydrogen generator parts and all substances used in the hydrogen generator shall be

- suitable for the range of temperatures and pressures to which the hydrogen generator is subjected during expected usage,
- resistant to the reactions, processes and other conditions to which the hydrogen generator is exposed during expected usage,
- suitable for their intended use, and
- used within their rating and in accordance with the manufacturer's instructions.

The hydrogen generator shall be designed to withstand expected shock and vibration loads, as well as the specified ambient temperature range during transportation to the installation site and use. Means shall be provided to facilitate safe handling of the hydrogen generator during lifting, moving and positioning operations. The hydrogen generator shall be designed to remain stable when subjected to normal operational forces imposed by users or by the environment during the installation or use.

The design of the hydrogen generator shall take into account the requirements specified in ISO 12100.

All parts of hydrogen generators, which are set or adjusted at the stage of manufacture and which should not be manipulated by the user or the installer, shall be appropriately protected.

Manual controls shall be clearly marked and designed to prevent inadvertent adjustment or activation.

All parts shall be adequately protected from climatic and environmental conditions anticipated by the operating conditions such as seismic-zone rating, snow, rain and wind loading.

All parts shall be of such construction as to be secure against displacement, distortion, warping or other damage that could affect their functionality.

All parts that may be contacted during normal usage, adjustment or servicing shall be free from sharp projections or edges.

All parts that require regular or routine maintenance or servicing, such as inspection, lubrication, cleaning, replacement or similar function, shall be accessible and protected from unauthorized access with the use of a special key or tool. All parts that are serviced by the residential user shall be accessible without exposing the user to any hazards.

Moving parts and parts containing liquid shall be designed and mounted in such a way that in all foreseeable modes of operation, the ejection of parts and liquid and the hazardous injection of liquid are prevented.

Where hazardous fluids are contained in the piping, precautions shall be taken in the design of the sampling and take-off points to ensure safety in accordance with the manufacturer's failure mode and effects analysis (FMEA). Where hazardous fluids are contained in the piping, the sampling and take-off points shall be clearly identified with cautionary symbols and protected from unauthorized access.

An FMEA pertaining to potential modes of failure and drift values for each safety-critical part shall be conducted (see 6.2.4.1).

The hydrogen generator or parts of it where persons are intended to move about or stand shall be designed and constructed to prevent persons slipping, tripping or falling on or off these parts.

5.2 General materials requirements

Materials employed in the hydrogen generator shall be suitable for their purpose.

All internal and external parts of the hydrogen generator that are directly exposed to moisture, ion transport medium, process gas streams of hydrogen or oxygen, as well as parts used to seal or interconnect the same, shall have the following material attributes during the manufacturer's rated service life:

- a) retain mechanical stability with respect to strength (fatigue properties, endurance limit, creep strength) when exposed to the full range of operating conditions specified in Clause 4;
- b) resist the chemical and physical action of the fluids that they contain and resist environmental degradation;
- c) be compatible with any other material used in conjunction so as to not have a synergistic and undesirable effect.

When selecting materials and manufacturing methods, due consideration shall be given to the following:

- hydrogen embrittlement and hydrogen-assisted corrosion, as indicated in Annex A and in ISO/TR 15916;
- oxygen compatibility;
- corrosion and wear resistance;
- electrical conductivity;
- electrical insulation;
- impact strength;
- aging resistance;
- temperature effects;
- galvanic corrosion;
- erosion, abrasion, corrosion or other chemical attack;
- resistance to ultraviolet (UV) radiation.

The auto-ignition temperature of any materials that may come into contact with oxygen during operation shall have ignition temperatures in pure oxygen atmosphere at the maximum operating pressure at least 50 °C greater than the maximum temperature to which they are exposed during operation.

Process piping and vessels carrying oxygen shall be cleaned in accordance with IEC/TR 60877.

5.3 Enclosures

5.3.1 Minimum strength

The supporting structure and the enclosure shall have the strength, rigidity, durability, resistance to corrosion and the other physical properties to support and protect all the components and piping, and withstand

mechanical stress and shock expected during transport, installation and operation of the hydrogen generator. Electrical enclosures shall meet the requirements of IEC 60204-1.

5.3.2 Environmental tolerance

The hydrogen generator enclosure shall be designed and tested for the intended installation environment as classified in IEC 60529.

The enclosure of hydrogen generators intended for indoor use shall, as a minimum, meet the IP 34C rating defined in IEC 60529.

The enclosure of hydrogen generators intended for outdoor use shall, as a minimum, meet the IP 54 rating defined in IEC 60529.

NOTE IEC 60068-2-68 provides recommended guidelines in test L for dust and sand.

5.3.3 Fire resistance

The hydrogen generator enclosure, together with the thermal insulating materials and their internal bonding or adhesive attachment means, as well as the adjacent walls specified in 6.1.8, shall have a flammability classification as follows:

- a) materials other than plastics shall have a flammability classification that will not support accelerating combustion after electrical and fuel gas sources are removed when tested as in ISO 1182;
- b) plastic enclosures that cover sources of combustion or enclose live parts shall comply with the requirements of 5V rated materials when tested in accordance with IEC 60695-11-20. Other plastic enclosures shall comply with the requirements of HB and V rated materials when tested in accordance with IEC 60695-11-10;
- c) composite materials shall meet the requirements of either a) or b) above.

5.3.4 Insulating materials

Thermal insulating materials on the enclosure of the hydrogen generator shall be mechanically or adhesively retained in place and shall be protected against displacement or damage from anticipated loads and service operation.

Thermal insulating materials and their internal bonding or adhesive attachment means shall withstand all air velocities and temperatures to which they may be subjected in normal operation.

5.3.5 Access panels

Access panels shall be designed according to the requirements given in ISO 15534-1 and ISO 15534-2.

Access panels, covers or insulation that need to be removed for normal servicing and accessibility shall be designed such that repeated removal and replacement will not cause damage or impair the insulating value. Compliance shall be determined by the tests in 10.1.14.

An access panel, cover or door shall have a means for retaining it in place or opening it and shall require the use of a tool, key or similar mechanical means to open. If located within classified areas, an access panel, cover or door shall be designed to not generate sparking in accordance with IEC 60079-0 when being opened or closed.

Removable access panels, covers and doors shall be designed so as to prevent them from being attached in an improper position or being interchanged in a manner that may interfere with proper operation of the hydrogen generator.

An enclosure large enough to admit service personnel to the enclosure shall have an access door that opens outwards and, if equipped with a latch, it shall be equipped on the inside with fast-release hardware that can be operated without a key or special tool.

5.3.6 Ventilation openings

Ventilation openings shall be designed so that they will not become obstructed during normal operation in accordance with the expected application.

Where personnel can fully enter the enclosure, ventilation openings shall have a minimum total area of 0,003 m² per m³ of enclosure volume.

5.3.7 Containment of hazardous liquid leakage

Where a hydrogen generator contains hazardous liquids that can be harmful to personnel or the environment, the hydrogen generator enclosure shall be designed to safely contain anticipated leaks as follows:

- a) the containment means shall have a capacity of 110 % of the maximum volume of the anticipated leak;
- b) a leak detector shall be fitted in the lowest area of the hydrogen generator enclosure where the leak would be expected to accumulate. The detector signal shall cause the hydrogen generator to alarm and, where possible, change the operating parameters to prevent further accumulation before 25 % of the maximum volume of the anticipated leak accumulates.

5.3.8 Prevention of electrostatic accumulation

A terminal connected to earth shall be installed on the enclosure to prevent electrostatic accumulation.

5.4 Pressure-bearing components

5.4.1 General requirements

Special consideration shall be given to the following aspects of pressure-bearing components:

- a) support, constraint, anchoring, alignment and pre-tension techniques to mitigate excessive stresses and strains being produced on flanges, connections, bellows or hoses;
- b) effects of sudden movement, high-pressure jets, water hammer, pressure-relieving-device actuations;
- c) means for drainage and cleaning of condensation during start-up and/or use occurring inside pressure-bearing components for fluids which could cause damage from water hammer, vacuum collapse, corrosion and uncontrolled chemical reactions;
- d) precautions in design and marking where explosive, flammable, or toxic fluids might be contained.

5.4.2 Built-in storage of hydrogen and other gases

If there is a need to store hydrogen or any pressurized gases other than oxygen, such as purge gas, calibration gas, etc., inside the hydrogen generator, those gases shall be stored in any of the following types of containers that are compatible with the particular gas being stored and the environmental conditions the hydrogen generator is designed for:

- a) aluminium cylinders meeting the requirements of ISO 7866;
- b) steel cylinders meeting the requirements of ISO 9809-1;
- c) hoop wrapped composite cylinders meeting the requirements of ISO 11119-1;
- d) fully wrapped fibre reinforced composite gas cylinders with load-sharing metal liners meeting the requirements of ISO 11119-2;
- e) fully wrapped fibre reinforced composite gas cylinders with non-load-sharing metallic liners or non-metallic liners meeting the requirements of ISO 11119-3;
- f) metal hydride cylinders meeting the requirements of ISO 16111;

g) cylinders and vessels of appropriate construction meeting the requirements of ISO 16528-1.

For containers designed for a) to f), the maximum allowable pressure as defined in ISO 16528-1 shall be the working pressure as defined in ISO 10286.

5.4.3 Cell stacks

Cell stacks shall be designed to withstand the applicable cell-stack pressure tests of 10.1.5 without rupture and permanent deformation.

If, during normal or abnormal operation, a pressure difference between the oxygen and hydrogen sides of the cell stacks can occur, the maximum design pressure difference shall be specified by the manufacturer. The failure mode and effect analysis required as in 6.2.4.1 shall determine the need to monitor the pressure differential between the oxygen and hydrogen sides and the conditions that will cause the hydrogen generator to shut down.

5.4.4 Piping, fittings and joints

Process piping and joints shall conform to the applicable piping standard of ISO 15649 with the following exception:

— Polymeric or elastomeric piping, tubing and joints shall be allowed for flammable fluid service.

The internal surfaces of piping shall be thoroughly cleaned to remove loose particles greater than 10 µm, and the ends of piping shall be carefully finished to remove obstructions and burrs.

To remove oil, the pipe, fittings, and joints in oxygen service shall be cleaned as in IEC/TR 60877.

Threaded portions of piping and associated component parts that connect externally to the hydrogen generator shall have threads conforming to ISO 15649.

Polymeric or elastomeric piping, tubing and joints shall be suitable for the combined maximum operating temperature, pressure and chemical and material exposure anticipated in service and during maintenance. They shall be made of a material with a low permeation rate and the enclosure shall have adequate ventilation if employed for flammable fluid service. Adequate mechanical strength shall be demonstrated through the pressure tests of 10.1.5.

Polymeric or elastomeric piping, tubing and joints shall be protected from mechanical damage within the hydrogen generator. Shielding may be used, as appropriate, to protect components against failure of rotating equipment or other mechanical devices housed within the hydrogen generator enclosure. Any compartment enclosing plastic or elastomeric components used to convey flammable fluids shall be protected against the possibility of overheating.

Any piping system conveying dry hydrogen or oxygen shall prevent static build-up, so as not to cause electric sparks inside and/or outside the piping or at the outlet of piping.

5.4.5 Compressors

If used, compressors shall be suitable for hydrogen use and for the pressures and temperatures to which they may be subjected under normal operating conditions.

Compressors shall be provided with the following:

- a) pressure-relief devices that limit each pressure stage to the maximum operating pressure for the compression cylinder and piping associated with that stage of compression;
- b) an automatic shutdown control for high discharge pressure and temperature and low suction pressure;
- c) an unloading device that captures blow-down gas for re-use, and/or safe venting where required, to restart the compressor after shutdown;
- d) when necessary, vibration isolation from the inlet and/or discharge pipe to the compressor suction line.

5.4.6 Pressure-relief devices

All pressurized systems and equipment shall be protected from overpressure by means of one or more pressure-relief devices of the self-destructive type, such as rupture disks and diaphragms, or of the re-sealable type, such as spring-loaded pressure safety valves (PSVs).

Pressure-relief devices shall be directly connected to equipment that is the potential source of the overpressure, with no interconnected isolation devices. Hydrogen and oxygen pressure-relief devices shall vent outside of the enclosure.

Relieved oxygen shall be addressed as required in 4.5. Relieved hydrogen shall be addressed as required in 4.6. If hydrogen is vented indoors, the ventilation requirements specified in 6.1.4 shall take into account the maximum hydrogen released from the pressure-relief devices. Installation instructions shall be provided to ensure that relieved gases that are vented outdoors are vented to a safe area.

Pressure safety valves shall meet the requirements of ISO 4126-1 or the standards referenced in ISO 16528-1. Rupture disks shall meet the requirements of ISO 4126-2 and ISO 4126-6 or the standards referenced in ISO 16528-1.

5.4.7 Pressure regulators

Pressure regulators shall be of the non-venting type or installation instructions shall be provided to ensure that the vents are piped to a safe location (see 12.3). Pressure regulators shall be suitable for hydrogen or oxygen use, as appropriate, and for the pressures and temperatures that will be encountered.

Pressure regulator actuators controlled by a pneumatic power source shall not have a diaphragm that is facing hydrogen in the opposite side and could leak air into hydrogen.

5.4.8 Shut-off valves

Shut-off valves shall be provided for all equipment and systems where containment or blockage of the process fluid flow is necessary during shutdown, testing, maintenance, or emergency conditions.

Shut-off valves shall be rated for the pressures and temperatures encountered and shall be suitable for the fluid media.

Actuators mounted on shut-off valves shall be temperature rated to withstand heat transferred from the valve body.

Automatically operated valves shall conform to the applicable parts of IEC 60534.

Automatically operated shut-off valves shall be of a type that will go to a fail-safe position.

5.5 Fans and ventilators

Fans and ventilators shall conform to IEC 60335-2-80 or ISO 12499 with the electrical requirements evaluated as in IEC 60204-1. Fans and ventilators shall be of a type suitable for the application.

5.6 Pumps

Pumps shall conform to ISO 13709, ISO 14847, IEC 60335-2-51 or IEC 60335-2-41, as applicable.

When used in hazardous locations, if pumps are equipped with a connection band (belt drive) between the motor and pump, it shall be made of antistatic material.

5.7 Heat transfer system

Any means of heat transfer, commensurate with the properties of the affected fluids or gases, may be used.

5.8 Connection to potable water

The quality and supply characteristics of the water to be used in the hydrogen generator shall be specified by the manufacturer.

If potable water is to be used as the feed-water, the hydrogen generator shall be provided with means to prevent any back-feeding into the potable water supply.

In addition, means shall be provided to prevent any coolant from the heat transfer system from back-feeding into the potable water supply.

6 Electrical equipment, wiring and ventilation

6.1 Fire and explosion hazard protection requirements

6.1.1 General requirements

Hydrogen generators shall be manufactured such that unintentional hydrogen releases during normal operation are precluded. Conformity shall be determined by the test of 10.2.5.

NOTE In operation, the potential volume of unintentional hydrogen release of a hydrogen generator without built-in hydrogen storage is limited by the rate of hydrogen production.

6.1.2 Area classification for hydrogen generators

The hydrogen generator enclosure shall be classified according to IEC 60079-10-1. Where appropriate, instructions shall be provided to define the classification and extent of classified areas surrounding the hydrogen generator as in IEC 60079-10-1 (see 12.3).

6.1.3 Protection requirements for equipment within classified areas

Equipment within classified areas shall comply with the requirements of IEC 60079-0 and the appropriate parts of IEC 60079 for the type(s) of protection used or IEC 60079-30-1.

When equipment is intended for operation under conditions not covered in the scope of the appropriate parts of IEC 60079 or in the scope of IEC 60079-30-1 (e.g. operation in an enriched-oxygen atmosphere), additional testing related specifically to the intended conditions of use shall be performed.

NOTE This is particularly important when the types of protection flameproof enclosures “d” (IEC 60079-1) and intrinsic safety “i” (IEC 60079-11) are applied.

6.1.4 Protection methods to prevent the accumulation of ignitable mixtures

Protection may be provided by passive or active means to ensure that gas mixtures remain below a volume fraction of 1 % hydrogen in air within the enclosure, except in dilution volumes. Computational fluid dynamics analysis, tracer gas, or similar methods such as those given in IEC 60079-10-1, may be used to determine the 1 % volume fraction of hydrogen in air dilution boundary and ventilation requirements.

NOTE 1 Refer to informative Annex B.

Passive methods include, but are not limited to:

- a) pipe orifices and similar methods of flow restriction to restrict the maximum release rate to a predictable value,
- b) use of joints that are permanently secured and constructed so that they limit the maximum release rate to a predictable value, and
- c) natural ventilation.

Active methods include, but are not limited to:

- a) comparison of hydrogen gas flow or pressure measurements relative to control settings to initiate protective measures such as de-energization of non-classified electrical equipment and initiation of ventilation when an out-of-specification condition is detected,
- b) constant ventilation sufficient to maintain an average hydrogen gas concentration within the enclosure, except in dilution volumes, below the maximum volume fraction of 1 % hydrogen based on the maximum anticipated hydrogen gas leak rate into the enclosure as determined by the manufacturer,
- c) a hydrogen gas detection system complying with the requirements of 6.1.9 that initiates ventilation at a volume fraction of 0,4 % hydrogen.

When ventilation is used as an active protection means, the required minimum ventilation rate shall maintain a volume fraction of hydrogen not exceeding 1 %, based on the maximum anticipated hydrogen gas leak rate into the enclosure as determined by the manufacturer.

NOTE 2 Sudden and catastrophic failure of vessels or piping systems need not be considered a leak scenario in this analysis when protection against such failures has already been contemplated in the vessel and piping design, and when instructions are provided to ensure that soundness is verified periodically.

When such active and/or passive protection measures are used, the area classification determined as in 6.1.2 and the protection requirements for electrical equipment as in 6.1.3 may be adjusted accordingly. Detection of hydrogen/air mixtures exceeding the maximum volume fraction of 1 % hydrogen shall cause hydrogen generation to stop and de-energization of non-classified electrical equipment. Failure of ventilation shall cause a shutdown of gas generation. Equipment that shall remain energized in the event of failure, such as the hydrogen gas detection system and ventilation equipment, shall be suitable for use in hazardous areas as in 6.1.3.

6.1.5 Additional protection measures for hydrogen generators where oxygen is purposely vented inside the hydrogen generator enclosure

When applicable, oxygen purposely vented inside the hydrogen generator enclosure shall be diluted sufficiently by a ventilation air stream to preclude a hazardous enriched-oxygen atmosphere within the hydrogen generator enclosure. Classified electrical equipment that could come in contact with enriched-oxygen mixtures shall be evaluated for their suitability under the possible conditions indicated in 6.1.3.

The design of the ventilation shall dilute the oxygen concentration such that any gas flow exiting the hydrogen generator enclosure to the surrounding environment will not create a hazardous condition. Where mechanical ventilation is used to dilute oxygen levels, means of detecting insufficient air ventilation and causing hydrogen generator shutdown shall be provided.

6.1.6 Ventilation

Whenever ventilation is used as in 6.1.4 or 6.1.5, the manufacturer shall specify at least the ventilation rate of the ventilation system.

Failure of ventilation shall cause a shutdown of gas generation.

6.1.7 Start-up purge

Hydrogen generator enclosures that rely on ventilation for protection against accumulation of ignitable mixtures as in 6.1.4 shall be purged with a minimum of five air changes at the maximum ventilation rate required for dilution prior to the energization of any devices that are not suitable for the area classification.

All equipment, which shall be energized prior to purging or in order to accomplish purging, shall be suitable for the area classification. Purging need not be performed at start-up if it can be demonstrated by use of natural ventilation as in 6.1.4 that the atmosphere within the enclosure and associated ducts is non-hazardous prior to energization of non-classified electrical equipment.

6.1.8 Ventilation of adjacent compartments

Where ventilated electrical or mechanical compartments are adjacent to the hydrogen gas generation compartment, they shall be at a positive pressure relative to the hydrogen gas generation compartment and meet the requirements of 5.3.3, unless equipment within the adjacent compartment is suitable for the area classification.

6.1.9 Hydrogen gas detection system

Hydrogen gas detectors used for safety shall comply with ISO 26142. The manufacturer shall ensure that the selection, installation, use and maintenance of hydrogen gas detectors are in accordance with IEC 60079-29-2. The hydrogen gas detector(s) shall be installed in optimum location(s) to provide the earliest detection of hydrogen gas such that their protective function can be proven.

The reliability of a hydrogen gas detection system used for safety-control purposes shall be evaluated for safety as required by Clause 7.

6.1.10 Ventilation system testing

The ventilation design and actual flow rates shall be verified by the qualification tests in 10.1.17.

6.2 Electrical equipment

6.2.1 General requirements

Electrical safety shall ensure protection against electrical shock, fire and burns during operation and routine maintenance activities.

Electrical clearance (through air) and creepage distances (over surfaces), as well as solid insulation thickness for electrical circuits, shall be in accordance with Clause 20 of IEC 60730-1:2010.

Wiring methods shall comply with the requirements of IEC 60204-1.

Electrical installation and service connection leads or terminals of an individual component shall be identified by number(s), letter(s), symbol(s) or a combination thereof, except when the component

- a) incorporates means which physically prevent incorrect wiring, or
- b) incorporates only two leads or terminals, the interchange of which does not change the operation of the component.

Wire for power circuits shall be colour coded to allow for consistent identification. Conductors shall be identified as in IEC 60445.

Equipment terminals shall be identified as in IEC 60445.

Electrical components and devices shall be

- suitable for their intended use and shall conform to the relevant IEC standard indicated in Table 1, and
- installed and used within their ratings and as in the manufacturer's instructions.

6.2.2 Grounding and bonding

Equipment shall be bonded and grounded as required by IEC 60204-1 with the following exception:

Parts that shall be isolated from ground to ensure safe and reliable operation of the process by limiting stray currents, such as electrolytic cell metal casings and parts, other electrolyte-carrying vessels and cell ancillary systems, such as feed water and cooling systems, shall be protected as required under IEC 60204-1 to prevent electric shock.

6.2.3 Overcurrent protection

Overload and overcurrent protection shall be provided to each electrical device, equipment and apparatus by means of circuit breakers, overload relays and fuses in accordance with IEC 60364-4-43 or IEC/TR 60269-5.

Table 1 — Requirements for electrical components

Type of electrical equipment		Standards
Main category	Specific equipment	
Circuit-breakers		IEC 60947-2
Switches, disconnectors, switch-disconnectors and fuse-combination units		IEC 60947-3
Contactors and motor-starters	Electrotechnical contactors and motor-starters	IEC 60947-4-1
	AC semiconductor motor controllers and starters	IEC 60947-4-2
	AC semiconductor controllers and contactors for non-motor loads	IEC 60947-4-3
Control circuit devices and switching elements	Electromechanical control circuit devices	IEC 60947-5-1
	Proximity switches	IEC 60947-5-2
	Proximity devices with defined behaviour under fault conditions	IEC 60947-5-3
	Electrical emergency-stop device with mechanical latching function	IEC 60947-5-5
Multiple function equipment	Automatic transfer switching equipment	IEC 60947-6-1
	Control and protective switching devices for equipment (CPS)	IEC 60947-6-2
Ancillary equipment	Terminal blocks for copper conductors	IEC 60947-7-1
	Protective conductor terminal blocks for copper conductors	IEC 60947-7-2
Low-voltage switchgear and controlgear assemblies	Type-tested and partially type-tested assemblies	IEC 60439-1
	Busbar trunking systems (busways)	IEC 60439-2
	Low-voltage switchgear and controlgear assemblies intended to be installed in places where unskilled persons have access for their use – Distribution boards	IEC 60439-3
	Assemblies intended to be installed outdoors in public places – Cable distribution cabinets (CDCs) for power distribution in networks	IEC 60439-5
Semiconductor converters		IEC 60146 (all parts)
Rotating electric machines (motors)		IEC 60034-1
Power supplies, rectifiers and DC cables		IEC 61204-1, IEC 61000 (applicable parts)
Switch mode power supplies		IEC 61558-2-17
Power transformers: including separating transformers, control transformers, isolating transformers, constant voltage transformers, and autotransformers		IEC 61558-1
Semiconductor devices		IEC 60747 (all applicable parts)

6.2.4 Safety circuit analysis

6.2.4.1 Failure mode and effects analysis (FMEA)

An FMEA pertaining to potential modes of failure and drift values for each safety-critical component of the hydrogen generator shall be conducted by the manufacturer.

NOTE IEC 60812 provides recommended guidelines for the FMEA. IEC 61025 provides recommended guidelines for Fault Tree Analysis.

6.2.4.2 Safety-control circuit

All the electrical components that have been identified as critical functional components based on the results of the FMEA shall be provided with a safety-control circuit. The design of the safety-control circuits shall be in accordance with IEC 61069-7 and IEC 61511-1.

The design of a safety-control circuit shall be such that failure of critical functional components will cause the hydrogen generator to go to a safe condition, as follows:

- a) the component will act to safely interrupt the intended function under its control, or
- b) the component will allow to complete an operational cycle, but will fail to start or will lock out on the subsequent cycle.

The safety-control circuit shall ensure that the interchange of the electrical installation and service connection leads or terminals of the critical functional component that failed, when physically interchangeable without alteration, do not activate the component nor result in normal operation of the component.

6.2.5 Electric heaters

Electric heaters shall conform to the applicable parts of IEC 60335. Suitable insulation material shall be used between the heater coil and its sheath. Airtight bonding shall be provided at both ends of the heater sheath. Insulation resistance between the heater coil and its sheath at the time of shipment shall meet the manufacturer's acceptance value. After the initial start-up, the insulation resistance shall be suitably controlled so as to keep the value greater than the manufacturer's recommendation.

7 Control systems

7.1 General

The hydrogen generator shall be equipped with a control system that is designed and constructed so that the hydrogen generator is safe and reliable and will prevent a dangerous condition from occurring.

The manufacturer shall perform a safety analysis to identify failures that can affect the system performance and/or safety. The safety analysis shall provide the basis to set the protection parameters required for the functionality of the safety circuit described in 6.2.4. The response time and accuracy of the instruments used for the detection and the actuation of a control shall be accounted for in the safety analysis.

The hydrogen generator shall be designed such that the single failure of a safety-control circuit component does not cascade into a hazardous situation. As indicated in IEC 60204-1, means to prevent cascade failure include but are not limited to:

- protective devices in the machine (e.g. interlocking guards, trip devices);
- protective interlocking of the electrical circuit;
- use of proven techniques and components;
- provision of partial or complete redundancy or diversity;

— provision for functional tests.

The control system shall incorporate safety devices and, where appropriate, monitoring devices such as indicators and/or alarms which enable and provide information for appropriate action to be taken, either automatically or manually, to keep the hydrogen generator operating within allowable limits.

If the manufacturer's safety analysis determines that hydrogen in air, hydrogen in oxygen or oxygen in hydrogen combustible gas mixture hazards require an emergency-stop function, then the emergency stop shall be initiated when the maximum volume fraction of 2 % hydrogen in air, 2 % hydrogen in oxygen or 3 % oxygen in hydrogen, is exceeded. The response time and accuracy of the instruments used for detection and actuation of a control shall be accounted for in the safety analysis.

Each operational mode of the hydrogen generator shall be indicated.

7.2 Control function in the event of failure

In case of a fault in the control circuit logic, or failure of or damage to the control circuit:

- a) the hydrogen generator shall not start unexpectedly;
- b) the hydrogen generator shall not be prevented from stopping if the stop command has been given;
- c) automatic or manual stopping of the moving parts shall be possible;
- d) the protective safety devices shall remain fully effective.

7.3 Programmable electronic equipment

Programmable electronic equipment for monitoring, testing and non-safety-critical functions shall meet the requirements of IEC 60204-1 and shall comply with IEC 61131-1 and IEC 61131-2. Programmable controllers used for safety-critical circuit control shall also comply with IEC 61508. For programmable controllers whose safety functions are fail-safe and of low complexity, Annex H of IEC 60730-1:2010 shall apply.

7.4 Start

The hydrogen generator shall have a start control that initiates operation of the hydrogen generator only when all safeguards prescribed in the manufacturer's safety analysis are in place and functional. Suitable interlocks shall be provided to secure correct sequential starting.

The hydrogen generator may be started only by intentional actuation of a control provided for this purpose.

NOTE Intentional actuation of a control is not required for restarting from a standby mode that is the result of a normal sequence of an automatic cycle.

7.5 Emergency stop

The hydrogen generator shall have an emergency-stop function that immediately removes power from systems that produce an actual or impending hazard that cannot be corrected by controls. The emergency-stop safety circuit shall be designed according to the requirements of IEC 60204-1.

When provided, emergency-stop push buttons shall be designed in accordance with ISO 13850. They shall be marked clearly and shall be easily accessible.

The emergency-stop function shall:

- a) stop hydrogen production and de-energize equipment that produced the uncorrectable hazardous condition as quickly as possible without creating additional hazards;
- b) initiate or permit the initiation of certain safeguard actions as determined by safety analysis;
- c) override all other functions and operations in all modes;

- d) be fitted with restart lockouts that require intentional reset before the hydrogen generator start is permitted;
- e) not initiate a hazardous condition upon reset.

Control and monitoring systems that can operate safely in the hazardous situation may be left energized to provide system information.

A separate emergency stop is not required when emergency switching off is provided as described in IEC 60204-1.

In addition to the requirements above, the hydrogen generator shall also be provided with a connection for an optional remote emergency-stop device (ESD).

7.6 Stop

The hydrogen generator shall have a stop function separate from the emergency-stop function that initiates a controlled cessation of hydrogen generator operation.

The hydrogen generator may be stopped immediately or in a controlled mode with power remaining available to designated systems as indicated by the manufacturer's safety analysis and the functional requirements of the hydrogen generator.

7.7 Self-correctable conditions

The hydrogen generator shall be controlled to operate within design limits of pressure, temperature, current, voltage, and hydrogen composition, as established by the manufacturer's safety analysis and the functional requirements of the hydrogen generator to ensure safe operation and rated gas generation capacity and quality. The hydrogen generator may correct operating parameters to operate at a partial rated capacity to stay within safe design limits. The manufacturer's documented technical specifications in Clause 12 shall describe these features.

NOTE For example, a high ambient temperature can limit the heat rejection capacity of the hydrogen generator; the hydrogen generator control can respond by reducing the water electrolysis rate to operate within safe process limits.

7.8 Interconnected installations

When the hydrogen generator is designed to work together with other equipment, the hydrogen generator shall provide effective means to communicate safety-related conditions between the hydrogen generator and such other equipment (see the functional tests of 10.1.4.3).

7.9 Safety components

Safety components shall comply with the safety requirements specified in the relevant ISO or IEC standards as far as they reasonably apply. Electrical safety components shall also comply with the requirements of Clause 24 of IEC 60335-1:2010.

Safety components shall incorporate appropriate safety factors as prescribed by the manufacturer's safety analysis to ensure that the alarm threshold lies far enough outside the limits to be registered, taking into account, in particular, the operating conditions of the installation and possible faults in the measuring system.

Safety devices shall:

- be so designed and constructed as to be reliable and suitable for their intended use;
- be independent of other functions, unless their safety functions cannot be affected by such other functions;
- comply with design principles in order to obtain suitable and reliable protection. These principles include, in particular, fail-safe modes, redundancy, diversity and self-diagnosis.

7.10 Remote control systems

Remote monitoring and control systems shall:

- a) be allowed only on hydrogen generators where remote start-up will not lead to an unsafe condition;
- b) not override locally set manual controls;
- c) not override protective safety controls.

Hydrogen generators that can be operated remotely shall have a local, labelled switch or other device that will prevent remote operation when service personnel perform inspection or maintenance.

7.11 Alarms

When alarms (audio, visual, etc.) are provided, they shall be unambiguous and easily perceived. Additionally, they shall not draw the users into a hazardous situation and not encourage the users to access the equipment and/or attempt repairs themselves.

The alarm may be provided locally, remotely, or both. The alarm signal should include sufficient information for a service person to diagnose the fault.

7.12 Purge gas quantity

When the purge gas is supplied in compressed gas containers, there shall be a readily apparent indication of the remaining gas supply. If the quantity of purge gas is insufficient for a proper purge, the hydrogen generator shall not be allowed to start or it shall shut down.

7.13 Reset

Reset shall return the hydrogen generator from a faulted state to a ready-to-start state.

Reset shall only be possible when all the safeguards prescribed in the manufacturer's safety analysis are in place and are functional. Resetting a hydrogen generator shall not initiate a hazardous condition.

7.14 Suspension of safeguards

Where it is necessary to suspend safeguarding (e.g. for performing maintenance), a mode-selection device or means capable of being secured in the desired mode shall be provided so as to prevent unintended operation.

8 Ion transport medium

8.1 Electrolyte

The electrolyte, whether liquid or solid, shall:

- a) be chemically stable with respect to environmental degradation over the full range of operating conditions and over the defined operating lifetime of the hydrogen generator or any of its subcomponents;
- b) not introduce any undesirable attribute in any other material used in conjunction, so as to have a synergistic and undesirable effect that neither materials would possess if used in isolation;
- c) not catalyze or serve to promote in any fashion parasitic side reactions, either of a chemical or an electrochemical form, that contaminates the product gases of hydrogen or oxygen;
- d) be selected from the aqueous bases, and solid polymeric materials with acidic function group additions;
- e) provide sufficient ionic conductivity and prevent degradation of the oxygen/hydrogen separator (membrane).

The manufacturer shall provide a mechanism for the safe containment and environmental disposal of the electrolyte upon either a planned released or unplanned event leading to the release of the electrolyte as in 5.3.7.

8.2 Membrane

The hydrogen generator shall be provided with a membrane to separate the product gas streams of oxygen and hydrogen. The membrane shall:

- a) be chemically stable with respect to environmental degradation over the full range of operating conditions;
- b) be selected from the group of natural fibres, synthetic polymers, ceramics or combinations of the above and shall not contain asbestos;
- c) provide sufficient ionic conductivity for the safe operation of the hydrogen generator;
- d) provide sufficient electrical resistivity for the safe operation of the hydrogen generator;
- e) provide sufficient mechanical strength for the designed differential pressure between anode and cathode cells when assembled;
- f) not leach out harmful impurities upon electrolysis operation;
- g) provide sufficiently low levels of cross-membrane hydrogen and oxygen gas permeability under hydrated operating condition so as to prevent a flammable gas mixture.

The manufacturer shall provide a mechanism for the safe environmental disposal of the membrane upon hydrogen generator disassembly and replacement. Should there be a possibility that the membrane material will become unstable over the defined operating lifetime of the hydrogen generator, the manufacturer shall:

- a) ensure that the material instability will not affect the safety of the hydrogen generator;
- b) incorporate monitoring devices that will monitor the effects of the membrane material instability.

9 Protection of service personnel

The exterior and interior of the hydrogen generator enclosure and the interior components shall be designed with due consideration to ISO 13857 and ISO 13854.

All live parts shall be protected from access by unauthorized personnel. Entrances to exposed live parts inside the hydrogen generator shall have warning signs prohibiting access by unqualified personnel.

Guarding shall be provided to protect the service personnel from any contact shock of exposed live parts, as well as from any rotating device.

All non-insulated live parts in a high-voltage circuit within the hydrogen generator compartments shall be located, guarded or enclosed so as to minimize the possibility of accidental contact by service personnel performing mechanical service functions which may have to be performed with the equipment energized.

An electrical control component that may require examination, adjustment, servicing or maintenance while energized shall be located and mounted with respect to other components and grounded metal parts so it is accessible for electrical service functions without subjecting the service personnel to the likelihood of shock hazard from adjacent non-insulated live parts or accident hazard from adjacent hazardous moving parts.

10 Test methods

10.1 Type (qualification) tests

10.1.1 General requirements

Each new hydrogen generator design considered for compliance with this part of ISO 22734 shall be subjected to the type (qualification) tests of 10.1 to verify that the design specification is fulfilled.

A hydrogen generator design tested for compliance with this part of ISO 22734 shall be a representative production sample.

10.1.2 Basic test arrangements

In conducting the tests, the entire hydrogen generator, including any air filters, start-up devices, venting or exhaust systems and all field-furnished equipment shall be installed in accordance with the manufacturer's instructions to replicate the manner in which it is to be installed and operated.

Unless otherwise stated, the entire hydrogen generator shall be operated

- a) at maximum normal operating pressure, and
- b) at the rated voltage and frequency.

Tests shall be carried out on the hydrogen generator assembled for normal use and under the least favourable combination and configuration, within the manufacturer's stated ratings.

10.1.3 Reference test conditions

10.1.3.1 Environmental conditions

Unless otherwise specified in this part of ISO 22734, the tests shall be carried out in the following environment:

- a) a temperature of 15 °C to 35 °C;
- b) a relative humidity of not more than 75 %, but not exceeding the limits of 4.3;
- c) an atmospheric pressure of 75 kPa to 106 kPa;
- d) no hoarfrost, dew, percolating water, rain, solar radiation, etc.

10.1.3.2 State of hydrogen generator

10.1.3.2.1 General

Unless otherwise specified, each test shall be carried out on the hydrogen generator assembled for normal use and under the least favourable combination of the conditions given in 10.1.3.2.2 to 10.1.3.2.13.

If dimensions or mass make it unsuitable to carry out particular tests on a complete hydrogen generator, tests on sub-assemblies are allowed, provided it is verified that the assembled equipment will meet the requirements of this part of ISO 22734.

Equipment intended to be built into a wall, recess, cabinet, etc., shall be installed as specified in the manufacturer's instructions.

10.1.3.2.2 Position of the hydrogen generator

The hydrogen generator shall be in any position of normal use and with any ventilation unimpeded.

10.1.3.2.3 Accessories

Accessories and user-interchangeable parts available from, or recommended by, the manufacturer for use with the equipment under test may be either connected or not connected.

10.1.3.2.4 Covers and removable parts

Covers or parts which can be removed without using a tool may be left in place or removed.

10.1.3.2.5 Mains supply voltage

The mains supply voltage shall be between 90 % and 110 % of any rated supply voltage for which the equipment can be set or, if the equipment is rated for a greater fluctuation, at any supply voltage within the fluctuation range.

The frequency shall be any rated frequency.

A hydrogen generator designed for both alternative current (a.c.) and direct current (d.c.) shall be connected to an a.c. or d.c. supply.

A hydrogen generator designed for d.c. or single-phase supply shall be connected both with normal and reverse polarity.

Unless the hydrogen generator is specified for use only on a non-earthed mains supply, one pole of the reference test supply shall be at or near earth potential.

If the means of connection permits reversal, battery-operated hydrogen generators shall be connected with both reverse and normal polarity.

10.1.3.2.6 Input and output voltages

Input and output voltages, including floating voltages but excluding the mains supply voltage, shall be set to any voltage within the rated voltage range.

10.1.3.2.7 Earth terminals

Protective conductor terminals, if any, shall be connected to earth. Functional earth terminals may be connected or not connected to earth.

10.1.3.2.8 Controls

Controls that can be adjusted by hand shall be set to any position except that:

- a) mains-selection devices shall be set to the correct value;
- b) combinations of settings shall not be made if they are prohibited by the manufacturer's marking on the equipment.

10.1.3.2.9 Connections

If the hydrogen generator is designed to work with other equipment as specified in 7.8, the hydrogen generator may be connected for its intended purpose, or not.

10.1.3.2.10 Load on motors

Load conditions of motor-driven parts of the hydrogen generator shall be in accordance with the intended purpose.

10.1.3.2.11 Output

The following shall be taken into account regarding the hydrogen generator equipment giving an electrical output:

- a) the equipment shall be operated in such a way as to provide the rated output power to the rated load;
- b) the rated load impedance of any output may be connected or not.

10.1.3.2.12 Duty cycle

Equipment for short-term or intermittent operation shall be operated for the longest period and shall have the shortest recovery period consistent with the manufacturer's instructions.

Equipment for short-term or intermittent operation that develops significant heat during the start-up phase, and that relies on continued operation to dissipate that heat, shall also be operated for the shortest rated period followed by the shortest rated recovery period.

10.1.3.2.13 Loading and filling

Equipment intended to be loaded with a specific material in normal use, such as a desiccant or electrolyte, shall be loaded with the least favourable quantity of the materials specified in the instructions for use, including not loaded (empty) if the instructions for use permit this in normal use.

In case of doubt, tests should be performed in more than one loading condition.

If the specified material could cause a hazard during the test, another material may be used, provided that it can be demonstrated that the result of the test is not affected.

10.1.4 Electrical tests**10.1.4.1 Continuity of the protective bonding circuit test**

The continuity of the protective bonding circuit specified in 6.2.2 shall be verified by a loop impedance test in accordance with 61.3.6.3 of IEC 60364-6:2006.

An alternative test method may be used for hydrogen generators with protective bonding loops not exceeding 30 m. In this case, the continuity of the protective bonding circuit shall be verified by the appropriate bonding impedance test as follows:

- 6.5.2.3 of IEC 61010-1:2010 for impedance of protective bonding of plug-connected equipment;
- 6.5.2.4 of IEC 61010-1:2010 for permanently connected equipment.

Another alternative test method may be used when and only when test equipment with current generating capacity required by the test of IEC 61010-1 is not readily available. In this case, the continuity of the protective bonding circuit shall be verified by the test of 19.2 of IEC 60204-1:2005.

It is recommended that the continuity of the protective bonding circuit be verified before power is applied to the hydrogen generator, as most short-circuit protective devices rely on this continuity for proper operation. Similarly, it is recommended that the continuity of the protective bonding circuit be verified before the voltage test of 10.1.4.2.

10.1.4.2 Strength of the electrical insulation

The strength of the electrical insulation specified in 6.2.1 shall be verified in accordance with 6.8 of IEC 61010-1:2010 with the following exceptions:

- humidity preconditioning is not required for hydrogen generators too large for readily available test chambers; the voltage testing requirements for such large hydrogen generators shall in no case be less than those of 19.4 of IEC 60204-1:2005;

- any of the tests of 6.8.4 of IEC 61010-1:2010 may be used.

NOTE If the hydrogen generator employs a component such as a solid-state device that can be damaged by the voltages specified in this test, and that component complies with the applicable International Standard specified in 6.2.1, the conductors of the circuit being tested may be disconnected at the component to eliminate the likelihood of damaging the component.

It is recommended that the voltage test be performed after the continuity of the protective bonding circuit is verified as in 10.1.4.1 to minimize the possibility of inadvertently energizing accessible conductive surfaces and to ensure proper operation of the test equipment.

It is recommended that the strength of the electrical insulation be verified before applying power to the hydrogen generator to minimize the potential for short circuits and exposure to hazardous voltages.

10.1.4.3 Functional tests

The functions of electrical equipment shall be tested, particularly those related to safety and safeguarding. At a minimum, the functioning of the safety-control circuit and components identified in 6.2.4 and the control system of Clause 7 shall be verified according to the requirements of 5.3.7, 6.2.4.1, 6.2.4.2, 7.1, 7.2, 7.4, 7.5, 7.9 and 7.11.

Where applicable, the following faults and conditions shall be considered in the analysis and testing for 6.2.4:

- a cell-stack voltage under/over the maximum/minimum voltage specified by the manufacturer;
- a cell-stack unbalanced voltage as specified by the manufacturer;
- a cell-stack temperature higher than the maximum temperature specified by the manufacturer;
- a cell-stack current over the maximum current specified by the manufacturer;
- a cell differential pressure higher than the maximum differential pressure specified by the manufacturer;
- an electrolyte level higher than the maximum level specified by the manufacturer;
- an electrolyte level lower than the minimum level specified by the manufacturer;
- an electrolyte flow rate lower than the lowest flow rate specified by the manufacturer;
- a volume fraction of hydrogen in air that exceeds the limits defined in 6.1.4 or 7.1;
- a volume fraction of hydrogen in oxygen that exceeds the limits defined in 7.1;
- a volume fraction of oxygen in hydrogen that exceeds the limits defined in 7.1;
- a pressure that is not compliant with the normal operating pressure limits specified by the manufacturer;
- an oxygen pressure higher than the maximum pressure specified by the manufacturer;
- a hydrogen compressor inlet pressure lower than the atmospheric pressure;
- an enclosure loss of ventilation;
- an ambient or process temperature higher than the maximum temperature specified by the manufacturer;
- an ambient or process temperature lower than the minimum temperature specified by the manufacturer;
- a hazardous liquid leak;
- feed-water purity below the minimum level specified by the manufacturer;
- operation of pressure-relief devices;
- limit switch failure;

- shutoff valve failure detected by the limit switch on the valve;
- emergency stop.

It is recommended that functional tests and especially those of the safety circuit be performed immediately after the continuity of the protective bonding circuit and the strength of the electrical insulation have been verified as in 10.1.4.1 and 10.1.4.2 and before the hydrogen generated is operated at full capacity.

10.1.4.4 Mains supply

The mains supply marking requirements of 11.2 shall be checked in accordance with 5.1.3 of IEC 61010-1:2010.

10.1.4.5 Touch current and protective conductor current

The touch current and protective conductor current shall be limited and tested in accordance with 5.1 of IEC 60950-1:2005.

10.1.4.6 Capacitor discharge

Cord-connected hydrogen generators shall comply with the capacitor discharge requirements outlined in 6.6.2 and 6.10.3 c) and d) of IEC 61010-1:2010.

10.1.4.7 Cord-anchorage pull force and torque tests

Cord-connected hydrogen generators shall be subjected to the test specified in 6.10.2 of IEC 61010-1:2010.

This test shall also be conducted on any external interconnecting electrical power cords employed on the hydrogen generator.

10.1.4.8 Terminals for external conductors test

Hydrogen generators that are permanently connected to the source of electrical supply shall be subjected to the test specified in 6.6.2 of IEC 61010-1:2010.

10.1.4.9 Starting current

Overcurrent protection designed in accordance with 6.2.3 shall not be susceptible to nuisance under normal start-up and operating conditions. To verify proper operation, the hydrogen generator shall be started and operated three times in succession without actuating an overcurrent protection device and without failure of any component.

10.1.5 Pressure test

10.1.5.1 General

All pressures cited in this clause are gauge unless stated otherwise.

10.1.5.2 Pressure test — Liquid-containing parts

The strength and integrity of all pressure-bearing parts of 5.4, including joints and connections, that convey a liquid shall be tested by the methods of 11.7 of IEC 61010-1:2010.

NOTE 1 Cell stacks need only be tested according to 10.1.5.4.

NOTE 2 Parts subjected to the same internal pressure during normal operation of the hydrogen generator through (inter) connection can be considered as an individual test section, which can be pressurized separately and, when deemed necessary, isolated from the rest of the hydrogen generator by any convenient means.

10.1.5.3 Pressure test — Gas and gas/liquid-mixture-containing parts

The strength and integrity of all pressure-bearing parts, including joints and connections, that convey a gas or a gas/liquid mixture shall be tested by the methods of 11.7 of IEC 61010-1:2010 with the following modifications:

- a) test pressure shall be at least 1,5 times design pressure;
- b) the minimum test pressure shall be 70 kPa;
- c) the test duration shall be 2 min ± 10 s.

NOTE 1 Cell stacks need only be tested according to 10.1.5.4.

NOTE 2 Parts subjected to the same internal pressure during normal operation of the hydrogen generator through (inter) connection can be considered as an individual test section, which can be pressurized separately and, when deemed necessary, isolated from the rest of the hydrogen generator by any convenient means.

If a pneumatic test is used, a non-reactive test gas, such as nitrogen or helium, is recommended.

NOTE 3 In addition to verifying the ability of the pressure-bearing parts to withstand pressure this test confirms the integrity of hydrogen containment system including piping, fittings, and vessels in support of the fire and explosion hazard protection requirements of 6.1. See 6.6 of IEC 60079-2:2007.

10.1.5.4 Pressure test — Cell stacks

10.1.5.4.1 Applicability

The cell stacks shall be subjected to the common pressure test of 10.1.5.4.2. If during normal or abnormal operation a pressure difference between the oxygen and hydrogen sides of the cell stacks can occur, the cell stack shall additionally be subjected to the differential pressure test of 10.1.5.4.3.

NOTE 1 A slightly different test is provided for cell stacks because unlike the other pressure-bearing components the cell stacks are the pressure source. If the cell stacks fail, the source of both pressure and hydrogen is removed.

NOTE 2 Robust cell stacks can be tested with the other pressure equipment in accordance with 10.1.5.2 and 10.1.5.3.

10.1.5.4.2 Common pressure test

The oxygen and hydrogen sides of each cell stack shall be connected to a common pressure source and tested simultaneously. The pressure test shall be performed as in 10.1.5.3, except that the cell stacks with a maximum design pressure ≤50 kPa shall be subjected to 1,3 times their maximum normal operating pressure for 30 min.

10.1.5.4.3 Differential pressure test

The cell stacks shall be heated or cooled to the maximum or minimum operating temperature, whichever is more severe. The pressure test shall be performed as in 10.1.5.3, except that the pressure will be applied to either the anode or cathode channels but not both and the test pressure shall be 1,3 times the maximum normal differential operating pressure.

Additionally, the leakage rate between anode and cathode sides shall be measured either continuously during the test, or before and after the pressurization. The leakage rate between anode and cathode side shall not increase as a result of this test and shall be within the manufacturer's specification for the temperature of the test. The measurements after the pressurization shall not deviate from the initial results by more than the accuracy and repeatability of both the instrumentation and the test set-up.

10.1.6 Leakage test

10.1.6.1 General

The leakage tests of 10.1.6.2 and 10.1.6.3 shall be performed to supplement the pressure tests of 10.1.5.

Any functional parts shall be caused to assume the open position so the required test pressure is exerted on all parts of the test section.

10.1.6.2 Normal leakage test

The tests of 10.1.5.2 through 10.1.5.4 shall be repeated on the fully assembled hydrogen generator with the following modifications.

- The test pressure shall be of no less than the maximum normal operating pressure.
- When the test pressure is reached, the flow of test fluid shall be stopped and the pressure in the hydrogen generator shall be monitored for at least 2 min. There shall be no measurable pressure drop. Temperature compensation shall be taken into account when determining pressure drops.
- In the case of cell stacks that have to be additionally subjected to the test of 10.1.5.4.3, the same requirements apply for the leakage rate between anode and cathode sides.

10.1.6.3 Additional leakage testing of hydrogen gas component connections and piping joints

In addition to the normal leakage test of 10.1.6.2, hydrogen gas conveying piping connections shall be leak tested in accordance with 10.1.6.3.1 or 10.1.6.3.2.

10.1.6.3.1 Bubble test

Using an inert test gas such as nitrogen or helium, hydrogen gas component systems shall be leak tested with a test pressure of no less than the maximum normal operating pressure. The leak test shall be carried out once the test pressure has been reached and hydrogen conveying piping joints and component connections completely covered with a leak detection liquid suitable for the surface. The leak detection liquid shall be applied in a manner to prevent bubbles as a result of the application process. Each hydrogen gas connection shall be pressurized for a minimum of 10 min. No visible bubbles produced by gas leakage shall be observed.

If the component to be tested has parts made of stainless steel, nickel, or chromium alloys, the test fluid shall have a volumetric fraction of less than 1×10^{-5} of sulfur and 1×10^{-5} of halogen. If the component to be tested has parts made of polyethylene or structural plastic, the test fluid shall not promote environmental stress cracking (E.S.C).

NOTE Electrochemical cells can be excluded from bubble test and contact with leak detection liquid.

10.1.6.3.2 Tracer gas leak detection

As an alternative to the bubble test, a calibrated trace gas detector using a non-flammable tracer gas in accordance with ISO 10156, such as a hydrogen and nitrogen mixture containing a volumetric fraction of hydrogen in nitrogen of less than 5,7 % or a helium mass spectrometer with helium gas, may be used to detect hydrogen conveying connection, cell stack and pipe joint leaks when used in accordance with instructions provided by the tracer gas detector manufacturer and the hydrogen generator manufacturer's requirements.

10.1.7 Dilution tests

Where mechanical ventilation is used to dilute hydrogen and/or oxygen as described in 6.1.4 and 6.1.5, the tests of 10.1.7.1 to 10.1.7.3 shall be performed.

The air pressure and airflow measured during the test conditions shall be corrected for temperature and altitude. The corrected airflow and pressure shall meet the design criteria for the specified operating range of the hydrogen generator.

For the dilution tests to be valid, the integrity of the containment system should have been confirmed by the tests of 10.1.5.3 and 10.1.5.4.

10.1.7.1 Air flow test

The air flow rate shall be measured to confirm that the flow rate meets or exceeds the ventilation rate specified in 6.1.6. The ventilation rate shall be determined by measuring air flow into or out of the hydrogen generator enclosure.

10.1.7.2 Air pressure test

The pressure of the ventilated enclosure shall be measured to confirm that the pressure differential meets the flow and pressure requirements specified in 6.1.6 and 6.1.8, as applicable.

10.1.7.3 Dilution test

The effectiveness of the dilution by ventilation specified in 6.1.4, 6.1.5 and 6.1.6 shall be confirmed using the method of 16.4.4.2 of IEC 60079-2:2007.

10.1.8 Protection against the spread of fire tests

Protection against the spread of fire shall be tested by the methods of Clause 9 of IEC 61010-1:2010.

NOTE The standards for fire resistance referenced in 5.3.3 contain additional tests.

10.1.9 Temperature tests

Protection against burns and the overheating of components shall be tested by the methods of Clause 10 of IEC 61010-1:2010.

Before the test, the accessible surfaces of the hydrogen generators shall be cleaned to remove foreign particles.

The hydrogen generators shall be subjected to this temperature test while installed in a test alcove constructed of panels of dull, black-painted plywood, approximately 20 mm thick for each panel.

Thermocouples used for determining temperature rises on the surface of the walls, ceiling and floor of the test alcove panels shall be attached to the back of small, blackened disks of copper or brass. The front of the disks shall be flush with the surface of the test panels.

For the test, the hydrogen generator shall be placed on one of the test panels used as a supporting surface and placed at a distance from the sidewalls and ceilings of the alcove as specified by the manufacturer's installation instructions. The hydrogen generator shall be positioned to create the highest temperatures on the tests surfaces where the temperature discs are located.

The hydrogen generator shall be installed and operated as outlined in 10.1.2. During the conduct of this test, all unused electrical connection openings shall be closed. When equilibrium conditions are attained, the temperatures of accessible surface(s) shall be determined.

The temperature of walls, floor and ceiling adjacent to the hydrogen generator shall not exceed 50°C above ambient temperature. Component temperature shall be within manufacturer's specification.

10.1.10 Environmental test

10.1.10.1 Ingress protection

The electrical enclosure and process enclosures of the hydrogen generator shall be tested according to IEC 60529 for compliance with the IP classification determined as in 5.3.2.

NOTE In addition to providing protection from the environment, enclosures might prevent access to hazardous live electrical parts as required by 6.2.1. See 6.2 of IEC 61010-1:2010 for more information and a preferred means of testing for this particular protection.

10.1.10.2 Water test

The electrical enclosure and process enclosures of hydrogen generators intended for outdoor use shall be tested by the methods of 6.3 of IEC 60068-2-18:2010 or by the methods of IEC 60529 to IPX5.

Where supplied with vent terminals, the hydrogen generator shall be tested with the shortest allowed length of vent in accordance with the manufacturer's instructions.

NOTE Components and equipment individually protected to levels required by this part of ISO 22734 (or better) do not need to be enclosed.

10.1.11 Performance tests**10.1.11.1 Hydrogen production rate test**

The hydrogen production rate shall be measured at 100 % capacity for a period of 1 h using the method defined in ISO 9300, ISO 9951, ISO 10790 or ISO 14511.

The average production rate shall meet or exceed the rate specified by the manufacturer.

10.1.11.2 Hydrogen quality test

The applicable hydrogen quality parameters shall be verified as in ISO 14687.

10.1.12 Overfill and drain test

Hydrogen generators subjected to spillage of liquid in normal use or in the event of a failed liquid drain line shall be constructed so that such spillage does not introduce electrical hazard.

Hydrogen generators subjected to spillage of liquid in normal use shall comply with the requirements of 11.3 and 11.4 of IEC 61010-1:2010.

Hydrogen generators having liquid disposal system(s) shall, under conditions of a blocked liquid drain line(s), continue to operate within compliance of manufacturer's specifications or stop operation.

The hydrogen generator under overfill and drain test shall comply with the requirements of 10.1.4.2, 10.1.4.5 and 10.1.7, as applicable.

10.1.13 Mechanical strength

Hydrogen generators shall be subjected to the mechanical strength tests of Clause 8 of IEC 61010-1:2010.

10.1.14 Construction tests

Hydrogen generators shall be subjected to the push force, pull force, axial pull force and torque tests outlined in Clause 22 of IEC 60335-1:2010.

10.1.15 Stability test

The hydrogen generator shall be subjected to the stability test of 20.1 of IEC 60335-1:2010. Hydrogen generators that are intended to be permanently connected may be exempted from this test.

10.1.16 Screws and connections

The hydrogen generator shall be subjected to the screw and connections test outlined in 28.1 of IEC 60335-1:2010.

10.1.17 Vent tests

10.1.17.1 General

The vent tests specified in 10.1.17.2 to 10.1.17.4.3 are applicable to hydrogen generators for indoor installation that are provided with a vent system by the manufacturer.

10.1.17.2 Vent leakage

The vent assembly shall comply with the leakage test requirements of 10.1.6.

The leakage test of 10.1.6 shall be conducted with the vent system assembled to the hydrogen generator as intended with the longest manufacturer recommended length of vent piping assembly and most parts attached.

10.1.17.3 Vent temperature test (non-metallic vent materials)

Vent systems employing materials affected by temperature shall be assembled and installed in accordance with the manufacturer's instructions for the temperature test of 10.1.9 on the system.

Temperatures shall be monitored in accordance with the temperature test requirements outlined in 10.1.9.

10.1.17.4 Mechanical strength of vent systems

10.1.17.4.1 General

The static force and impact tests of 10.1.17.4.2 and 10.1.17.4.3 shall be conducted with the vent system assembled to the hydrogen generator as intended with the longest recommended length of vent piping assembly and maximum parts installed.

10.1.17.4.2 Static force

In order to perform the test, a vertical suspension load of 70,0 kg shall be evenly distributed (without impact) over the vent terminal. The load shall then be removed. The vent terminal shall not be distorted or altered in a way that would result in the hydrogen generator not operating satisfactorily or in leakage of vented gases.

Following the static force test, the hydrogen generator shall comply with the leakage test in accordance with 10.1.6.

10.1.17.4.3 Impact

The horizontal vent terminal supplied with the hydrogen generator shall be subjected to an impact test as follows:

The impact shall be produced by a pendulum consisting of a cloth bag, filled with sand, weighing 12 kg suspended from a steel cable or rope. The bag shall be formed from a flat section of burlap, canvas, or other suitable material. A suitable plastic liner may be used to prevent sand loss. All sides and corners of the cloth shall be drawn up as tightly as possible around the sand and the excess material tied as close as possible at the top of the bag. The bag shall have an at-rest position not more than 25 mm from the edge of the bag to the nearest edge of the vent terminal (see Figure 1).

The point of impact shall be at the height of the centre of gravity of the bag. The angle of swing shall be 45° and it shall be measured between the pendulum arm with the bag at its at-rest position and the pendulum arm at its elevated position. The length of the pendulum, measured from the point of rotation to the centre of gravity of the bag as shown in Figure 1, shall be 2 m.

One impact shall be made at each of the following points:

- a) at the centre of the vertical front surface of the vent terminal,

- b) at the leading edge on the left side of the vent terminal, pendulum rotated left at an angle 45° from the point described in a),
- c) at the leading edge on the right side of the vent terminal, pendulum rotated right at an angle 45° from the point described in a).

Following the impacts, the hydrogen generator shall show compliance with the leakage test of 10.1.6.

At the option of the manufacturer the vent terminal may be replaced following each impact.

All dimensions are in millimetres

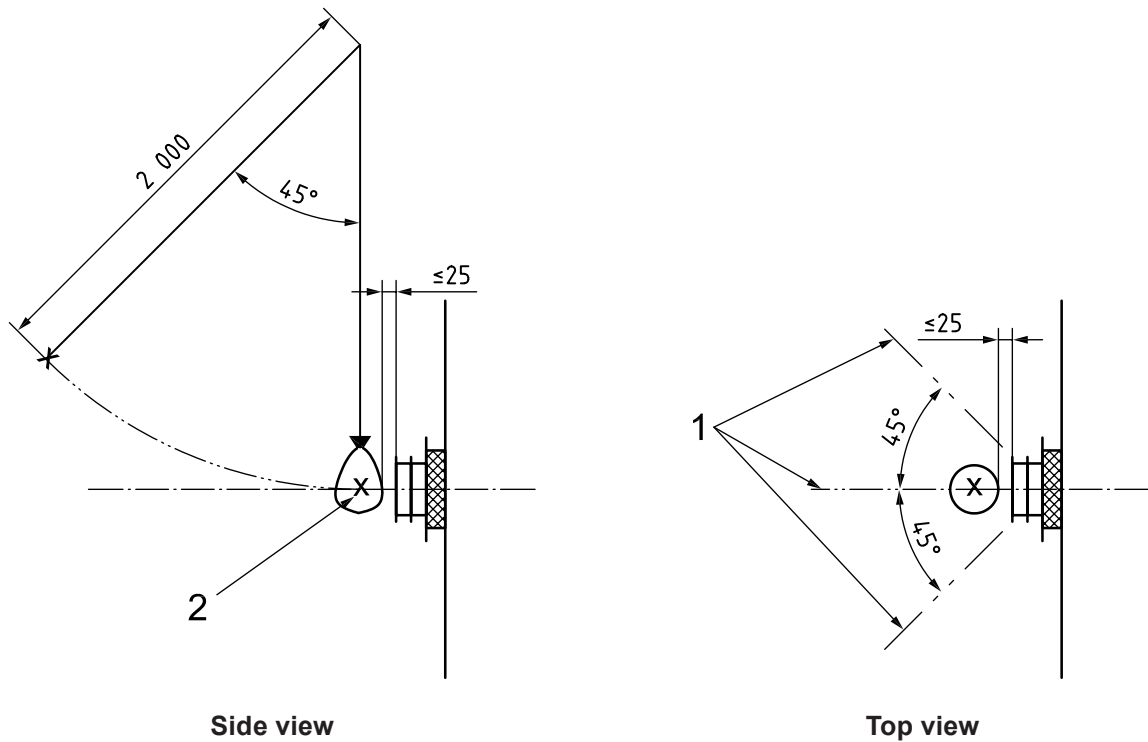

Key

- 1 sandbag path
- 2 centre of gravity of the 12 kg sandbag

Figure 1 — Impact test set-up

10.2 Routine tests

10.2.1 General requirements

Routine tests shall be performed on every hydrogen generator.

10.2.2 Continuity of the protective bonding circuit test

The continuity of the protective bonding circuit shall be tested as specified in 10.1.4.1 of this part of ISO 22734 or as in F.1 of IEC 61010-1:2010.

NOTE Any of the alternative methods listed in 10.1.4.1 can be used, regardless of the size or ratings of the hydrogen generator.

10.2.3 Voltage test

The electrical insulation shall be tested as specified in 10.1.4.2 of this part of ISO 22734 or as in F.2 and F.3 of IEC 61010-1:2010.

10.2.4 Functional tests

At a minimum, the following functions of each hydrogen generator shall be verified when connected to rated electrical mains and utilities:

- function of safety-control circuit and each associated sensor and component;
- normal system start with no system warnings or alarms;
- normal generation of hydrogen at specified output rate and pressure within rated temperature with no system warnings or alarms for a duration sufficient for having the electrolyte reach and stabilize at its nominal temperature;
- normal system stop with no system warnings or alarms.

10.2.5 Leakage test

The integrity of each hydrogen generator's piping shall be tested as specified in 10.1.6. The integrity of each hydrogen generator's cell stack shall be tested as specified in 10.1.5.4, except that temperature shall be in accordance with manufacturer's standard routine test protocol.

11 Marking and labelling

11.1 General requirements

The hydrogen generator shall be marked in compliance with the applicable clauses of ISO 3864-2 and ISO 17398.

11.2 Hydrogen generator marking

Each hydrogen generator shall bear a data plate or combination of adjacent labels located so as to be easily read when the hydrogen generator is in a normally installed position. The data plate/label(s) shall include the following information:

- a) manufacturer's name (with trademark), and location;
- b) catalogue number and the model number or type;
- c) date of construction;
- d) electrical input in volts (single value or range);
- e) current rating in amperes or the rated power (watts or VA);
- f) frequency in hertz and phases;
- g) serial number of the hydrogen generator;
- h) IP rating for outdoor or indoor use;
- i) capacity of generation of hydrogen in cubic metres per hour at a temperature of 273,15 K (0 °C) and an atmospheric pressure of 101,325 kPa;
- j) hydrogen output pressure, in kilopascals;
- k) hydrogen quality as specified in ISO 14687;

- l) temperature of output hydrogen in degrees Celsius (°C);
- m) water use rate, in litres per hour;
- n) reference to this part of ISO 22734;
- o) hydrogen generators containing hazardous areas as determined in 6.1.1 shall be marked as required by IEC 60079-0 and the appropriate parts of IEC 60079 for the type(s) of protection.

11.3 Marking of components

All types of valves, transmitters, motors, pumps and fans shall be identified to match the hydrogen generator drawings. Piping and tubing shall be marked to identify contents and flow direction. Inlet and outlet ports and manual controls shall be marked to identify them. Convenience outlet, if provided, shall be marked with maximum current ratings. Replaceable fuses shall have fuse replacement markings near the fuse.

11.4 Warning signs

Warning signs shall be appropriately placed to identify electrical hazards, potential hazards associated with indoor hydrogen venting if applicable (see 4.6.3), contents from drain valves, potential hazards associated with the liquids contained in the hydrogen generator, hot components and mechanical hazards. Signs shall conform to ISO 3864-2.

12 Documentation accompanying the hydrogen generator

12.1 General

Hydrogen generators shall be accompanied by documentation for safety purposes as follows:

- a) intended use of the hydrogen generator;
- b) technical specification;
- c) instructions for use;
- d) name and address of manufacturer or supplier from whom technical assistance may be obtained;
- e) the information specified in 12.2 to 12.5;
- f) instructions for storage and transportation.

If applicable, warning statements and a clear explanation of warning symbols marked on the hydrogen generator shall be provided in the documentation or shall be durably and legibly marked on the hydrogen generator. In particular, there shall be a statement that documentation needs to be consulted in all cases where the "Caution, risk of danger" symbol of ISO 7010, is used, in order to find out the nature of the potential HAZARD and any actions which have to be taken.

If NORMAL USE involves the handling of hazardous substances, instruction shall be provided on correct use and safety provisions. If any hazardous substance is specified or supplied by the equipment manufacturer, the necessary information on its constituents and the correct disposal procedure shall also be provided.

Some examples of hazardous substances that hydrogen generators may contain, produce, or use are hydrogen, oxygen, purge gases, and electrolytes.

When symbols are used, they shall be as follows:

- symbols specified in IEC 60417, ISO 7000 and ISO 7010:
 - 3~ three-phase alternating current;

- 3N~ three-phase alternating current with neutral;
- the symbol for nature of supply shall be placed next to the marking for rated voltage;
- units of physical quantities and their symbols shall be those of the International System of Units.

NOTE Additional symbols are allowed, provided that they do not give rise to misunderstanding.

12.2 Hydrogen generator ratings

Documentation shall include the following:

- a) the supply voltage or voltage range, frequency or frequency range, and power or current rating;
- b) a description of all input and output connections;
- c) the rating of the insulation of external circuits, appropriate for single fault conditions, if such circuits are nowhere accessible (see 6.6.2 of IEC 61010-1:2010 or 3.6.3 of IEC 60335-1:2010);
- d) a statement of the range of environmental conditions for which the equipment is designed (see 4.3);
- e) a statement of the degree of protection, if the equipment is rated according to IEC 60529.

12.3 Hydrogen generator installation

12.3.1 General

The documentation shall include installation and specific commissioning instructions (examples are listed below) and, if necessary for safety, warnings against hazards which could arise during installation or commissioning of the hydrogen generator:

- a) assembly, location and mounting requirements;
- b) instructions for protective earthing;
- c) connections to the supply;
- d) requirements for special services, for example, air, cooling liquid;
- e) the maximum sound power level produced by equipment which emits sound, if measurement is required by 12.3.5;
- f) instructions relating to sound pressure level (see 12.3.5);
- g) instructions related to lifting hydrogen generators that are not portable (see 12.3.5);
- h) oxygen venting requirements (see 4.5);
- i) hydrogen venting requirements (see 4.6);
- j) requirements to prevent the formation of hazardous areas (see 6.1);
- k) connections to other equipment;
- l) Clearance distance to allow for operation, maintenance, and service.

12.3.2 Specific requirements for permanently connected hydrogen generators

The instructions for permanently connected hydrogen generators shall include information with regard to the following:

- a) supply wiring requirements;

- b) requirements for any external disconnect switch or circuit-breaker and external over current protection devices and a recommendation that the switch or circuit-breaker shall be near the equipment.

12.3.3 Specific requirements for indoor installations

The instructions for indoor installations of hydrogen generators shall include ventilation requirements. For the case of oxygen and hydrogen vented outdoors, ventilation requirements shall be specified with the purpose of avoiding, as applicable,

- a) accumulation of leaked oxygen,
- b) accumulation of leaked hydrogen, or
- c) excessive temperature elevation.

These ventilation requirements shall be expressed in form of means, such as size and location of openings to outdoors.

For the case of oxygen and/or hydrogen vented indoors, ventilation requirements shall be specified with the purpose of avoiding, as applicable,

- a) excessive oxygen enrichment of air as specified in 4.5.2;
- b) excessive hydrogen concentration in air as specified in 4.6.3, considering also potential leaks;
- c) excessive temperature elevation.

These ventilation requirements shall be expressed as minimum flow rate of natural and/or mechanical ventilation.

12.3.4 Specific requirements for built-in appliances

The instructions for built-in appliances shall include information with regard to the following:

- dimensions of the space to be provided for the appliance;
- dimensions and position of the means for supporting and fixing the appliance within this space;
- minimum distances between the various parts of the appliance and the surrounding structure;
- minimum dimensions of ventilating openings and their correct arrangement;
- connection of the appliance to the supply mains and the interconnection of any separate components;
- necessity to have the plug accessible after installation, unless the appliance incorporates a disconnect switch.

12.3.5 Lifting

The documentation for hydrogen generators that are not portable shall include lifting information and instructions, including:

- a) mass;
- b) centre of gravity;
- c) lifting points;
- d) suitable types of lifting accessories.

12.3.6 Sound level

If equipment produces noise at a level which could cause a hazard, the manufacturer shall measure the maximum sound pressure level which the equipment can produce and calculate the maximum sound power

level in accordance with ISO 3746 or ISO 9614-1. Sound from alarms and parts at remote locations shall not be included in the calculation.

Installation instructions shall specify how the service personnel can ensure that the sound pressure level from equipment, at its point of use after installation, will not reach a value which could cause a hazard. These instructions shall identify readily available and practicable protective materials or measures which may be used, including the fitting of noise-reducing baffles or hoods. The instructions for use should recommend that the sound pressure level be measured or calculated by the service personnel both at the user's position in normal use and at whatever point 1 m from the enclosure of the equipment has the highest sound pressure level.

NOTE A sound pressure level of 85 dBA above a reference sound pressure of 20 µPa is at present regarded by many authorities as the threshold at which a hazard might be caused. Special means, such as the use of protective earpieces, can make a higher level non-hazardous to the user.

Conformity shall be checked by measuring the maximum A-weighted sound pressure level at the user's position and at bystander positions, and if necessary, calculating the maximum A-weighted sound power level produced by the equipment, in accordance with either ISO 3746 or ISO 9614-1. The following conditions apply.

- a) During measurement, any part necessary for the correct operation of the equipment and supplied by the manufacturer as an integral part of such equipment, for example, a pump, shall be fitted and operated as in normal use.
- b) Sound level meters used in the measurement shall conform either to type 1 of IEC 61672-1 or, if an integrated sound level meter, to type 1 of IEC 61672-2.
- c) The test room shall be semi-reverberant, with a hard reflecting floor. The distance between any wall or any other object and the surface of the equipment shall not be less than 3 m.
- d) The equipment shall be tested with the combination of load and other operating conditions (for example, pressure, flow, and temperature) which creates the maximum sound pressure level.

12.4 Hydrogen generator operation

Instructions for use shall include, if applicable:

- a) identification of operating controls and their use in all operating modes;
- b) an instruction not to position the equipment so that it is difficult to operate the disconnecting device;
- c) instructions for interconnection to accessories and other equipment, including indication of suitable accessories, detachable parts and any special materials;
- d) specification of limits for intermittent operation;
- e) an explanation of symbols related to safety which are used on the equipment;
- f) instructions for replacement of consumable materials;
- g) instructions for cleaning and decontamination;
- h) a statement listing any potentially poisonous or injurious gases that can be liberated from the equipment, and possible quantities;
- i) condition of electrolyte replacement/replenishment to maintain the generator's operation within design parameters;
- j) room ventilation requirements as in 4.6.3 and 4.5.2.

There shall be a statement in the instructions that, if the equipment is used in a manner not specified by the manufacturer, the protection provided by the equipment may be impaired.

Instructions for use required by this part of ISO 22734 shall be provided in an official language of the country in which the hydrogen generator is to be sold.

The operation manual shall be such that all information the user needs to safely operate the hydrogen generator is readily and comprehensively accessible. For example, a copy of the operating instructions can be provided as a marking on the generator visible after installation or in a folder kept with the generator for ease of access.

12.5 Hydrogen generator maintenance

Instructions for the service personnel concerning preventive maintenance and inspection necessary for safety shall be given in sufficient detail. These shall include the inspection and replacement, if necessary, of any hoses or other parts containing fluids, if their failure could cause a hazard (see 10.1.3, 10.1.4 and 10.1.5). These shall also include the inspection and, if necessary, re-establishment of clear intake and exhaust openings and safety distances specified in the installation instructions.

A maintenance schedule including preventative and routine maintenance and indicating at a minimum the type and frequency of each maintenance item shall be provided. This shall address in particular protective (safety related) devices, interlocks, and circuits.

Instructions should advise the service personnel of any tests necessary to check that equipment is still in a safe condition. They should also warn against the repetition of any tests of this part of ISO 22734, which could damage the equipment and reduce protection against hazards.

For equipment using replaceable batteries, the specific battery type shall be stated.

The manufacturer shall specify any parts which are required to be examined or supplied only by the manufacturer or his agent.

The ratings and characteristics of replaceable fuses shall be stated.

Annex A (informative)

Hydrogen-assisted corrosion

Users of this part of ISO 22734 should be aware that engineering materials at high stress and high temperature and exposed to atomic hydrogen in their service environment may exhibit an increased susceptibility to hydrogen-assisted corrosion, commonly known as “hydrogen embrittlement”. Hydrogen embrittlement is defined as a process resulting in a decrease of the toughness or ductility of a metal due to the presence of atomic hydrogen.

Hydrogen embrittlement has been recognized classically as being of two types. The first, known as internal hydrogen embrittlement, occurs when the hydrogen enters the metal matrix through material processing techniques, which supersaturate the metal with hydrogen. The second type, environmental hydrogen embrittlement, results from hydrogen being absorbed by solid metals from the service environment. Thus, hydrogen embrittlement can occur during elevated-temperature thermal treatments and in service during electroplating, contact with maintenance chemicals, corrosion reactions, cathodic protection, and operating in high-pressure, high-temperature hydrogen.

In the absence of residual stress or external loading, environmental hydrogen embrittlement is manifested in various forms, such as blistering, internal cracking, hydride formation, and reduced ductility. With a tensile stress or stress-intensity factor exceeding a specific threshold, the atomic hydrogen interacts with the metal to induce subcritical crack growth leading to fracture.

The following are some general recommendations for managing the risk of hydrogen embrittlement.

- Select raw materials with a low susceptibility to hydrogen embrittlement by controlling chemistry, microstructure, and mechanical properties.
- When plating parts, manage anode/cathode surface area and efficiency, resulting in proper control of applied current densities. High current densities increase hydrogen charging.
- Clean the metals in non-cathodic alkaline solutions and in inhibited acid solutions.
- Use abrasive cleaners for materials having a hardness of 40 HRC or above.
- Use process control checks, when necessary, to mitigate risk of hydrogen embrittlement during manufacturing.

ISO/TR 15916 and ISO 11114-4 also provide guidance on material resistance to hydrogen embrittlement.

Annex B (informative)

Flammability limits of hydrogen

B.1 Flammability limit

Flammability limit is defined as vapour concentrations (usually reported as a volume fraction) of fuel (hydrogen) in a flammable mixture that will ignite and propagate a flame.

B.2 Flammability limits of hydrogen

As indicated in ISO/TR 15916, the flammability limits for hydrogen in air under ambient conditions range from a volume fraction of 4 % to 75 % of hydrogen in air.

These facts combined with changing nomenclature conventions has led to some confusion between standard references to the lower flammability limit (LFL), the lower explosive limit (LEL), and design limits as percentages of these.

Design limits prescribed in this part of ISO 22734 are conservatively well outside the volume fraction of 4 % to 75 % of hydrogen in air.

Bibliography

- [1] ANSI B11.TR3, *Risk Assessment and Risk Reduction — A Guideline to Estimate, Evaluate, and Reduce Risks Associated with Machine Tools*(ref. Subclause 6.3.5.5)
- [2] ANSI Z21.21, *Automatic Valves for Gas Appliances* (ref. Subclause 5.4.7)
- [3] ANSI/ASME B31.3, *Process piping* (ref. Subclause 5.4.3)
- [4] ANSI/CGA Z21.18, *Gas Appliance Pressure Regulators* (ref. Subclause 5.4.6)
- [5] ANSI/CGA Z83.8/2.6-M96, *Gas Unit Heaters* (ref. Subclause 5.5)
- [6] ANSI Z83.8, *Gas Unit Heaters, Gas Packaged Heaters, Gas Utility Heaters and Gas-Fired Duct Furnaces*
- [7] ANSI/CSA Z21.80, *Line Pressure Regulators* (ref. Subclause 5.4.6)
- [8] ANSI/UL 144, *LP Gas Regulators* (ref. Subclause 5.4.6)
- [9] ANSI/UL 252, *Compressed Gas Regulators* (ref. Subclause 5.4.6)
- [10] ANSI/UL 499, *Electric Heating Appliances* (ref. Subclause 5.5)
- [11] ANSI/UL 705, *Power Ventilators* (ref. Subclause 5.7)
- [12] ANSI/UL 823, *Electric Heaters for Use in Hazardous (Classified) Locations* (ref. Subclause 5.5)
- [13] ANSI/UL 1025, *Electric Air Heaters* (ref. Subclause 5.5)
- [14] EN 334CGA G-4.3-1980, *Commodity Specification for Oxygen* (ref. Subclause 4.8)
- [15] EN 563, *Safety of machinery — Temperature of touchable surfaces — Ergonomics data to establish temperature limit values for hot surfaces* (ref. Subclause 10.1.6)
- [16] EN 954-1, *Safety of machinery — Safety related parts of control systems — Part 1: General principles for design* (ref. Subclause 6.3.5.5)
- [17] EN 1050, *Safety of machinery — Principles for risk assessment* (ref. Subclause 6.3.5.5)
- [18] EN 1330-8, *Non-destructive testing — Terminology — Part 8: Terms used in leak tightness testing* (ref. Subclauses 10.1.3 and 10.1.4)
- [19] EN 1779, *Non-Destructive testing — Leak testing — Criteria for method and technique selection* (ref. Subclauses 10.1.3 and 10.1.4)
- [20] EN 12266-1, *Industrial valves — Testing of valves — Part 1: Pressure tests, test procedures and acceptance criteria — Mandatory Requirements* (ref. Subclause 5.4.7)
- [21] EN 13192, *Non-destructive testing — Leak testing — Calibration of reference leaks for gases* (ref. Subclauses 10.1.3 and 10.1.4)
- [22] EN 13202, *Ergonomics of the thermal environment — Temperatures of touchable host surfaces: Guidance for establishing surface temperature limit values in product standard* (ref. Subclause 10.1.6)
- [23] EN 13625, *Non-destructive testing — Leak testing — Guide to selection of instrumentation for the measurement of gas leakage* (ref. Subclauses 10.1.3 and 10.1.4)
- [24] ICG Doc 13/02/E, *Oxygen Pipeline Systems* (ref. Subclause 5.4.3)
- [25] IEC 60335-2-35, *Household and similar electrical appliances — Safety — Part 2-35: Particular requirements for instantaneous water heaters*

- [26] IEC 60335-2-73 *Household and similar electrical appliances — Safety — Part 2-73: Particular requirements for fixed immersion heaters*
- [27] IEC 60068-2-68, *Environmental testing — Part 2-68: Tests — Test L: Dust and sand*
- [28] IEC 60079-1, *Explosive atmospheres — Part 1: Equipment protection by flameproof enclosures “D”*
- [29] IEC 60079-11, *Explosive atmospheres — Part 11: Equipment protection by intrinsic safety “i”*
- [30] IEC 60730-2-17, *Automatic electrical controls for household and similar use — Part 2-17: Particular requirements for electrically operated gas valves, including mechanical requirements* (ref. Subclause 5.4.7)
- [31] IEC 60812, *Analysis techniques for system reliability — Procedure for failure mode and effects analysis (FMEA)* (ref. Subclause 7.1)
- [32] IEC 61025, *Fault tree analysis (FTA)* (ref. Subclause 7.1)
- [33] IEC 61032, *Protection of persons and equipment by enclosures — Probes for verification*
- [34] IEC 61511-3, *Functional safety — Safety instrumented systems for the process industry sector — Part 3: Guidance for the determination of the required safety integrity levels* (ref. Subclause 6.3.5.5)
- [35] IEC 61882, *Hazard and operability studies (HAZOP studies) — Application guide* (ref. Subclause 7.1)
- [36] ISO 37, *Rubber, vulcanized or thermoplastic — Determination of tensile stress-strain properties* (ref. Subclause 5.4.3)
- [37] ISO 188, *Rubber, vulcanized or thermoplastic — Accelerated ageing and heat resistance tests* (ref. Subclause 5.4.3)
- [38] ISO 1307, *Rubber and plastics hoses — Hose sizes, minimum and maximum inside diameters, and tolerances on cut-to-length hoses* (ref. Subclause 5.4.3)
- [39] ISO 1402, *Rubber and plastics hoses and hose assemblies — Hydrostatic testing* (ref. Subclause 5.4.3)
- [40] ISO 1431-3, *Rubber, vulcanized or thermoplastic — Resistance to ozone cracking — Part 3: Reference and alternative methods for determining the ozone concentration in laboratory test chambers* (ref. Subclause 5.4.3)
- [41] ISO 1436, *Rubber hoses and hose assemblies — Wire-braid-reinforced hydraulic types for oil-based or water-based fluids — Specification* (ref. Subclause 5.4.3)
- [42] ISO 4672, *Rubber and plastics hoses — Sub-ambient temperature flexibility tests* (ref. Subclause 5.4.3)
- [43] ISO 8031, *Rubber and plastics hoses and hose assemblies — Determination of electrical resistance and conductivity* (ref. Subclause 5.4.3)
- [44] ISO 10156, *Gases and gas mixtures — Determination of fire potential and oxidizing ability for the selection of cylinder valve outlets*
- [45] ISO 11114-1, *Gas cylinders — Compatibility of cylinder and valve materials with gas contents — Part 1: Metallic materials* (ref. Subclause 5.4.3)
- [46] ISO 11114-2, *Gas cylinders — Compatibility of cylinder and valve materials with gas contents — Part 2: Non-metallic materials* (ref. Subclause 5.4.3)
- [47] ISO 11114-3, *Gas cylinders — Compatibility of cylinder and valve materials with gas contents — Part 3: Autogenous ignition test for non-metallic materials in oxygen atmosphere* (ref. Subclause 5.4.3)
- [48] ISO 11114-4, *Transportable gas cylinders — Compatibility of cylinder and valve materials with gas contents — Part 4: Test methods for selecting metallic materials resistant to hydrogen embrittlement*

- [49] ISO 14113, *Gas welding equipment — Rubber and plastics hose and hose assemblies for use with industrial gases up to 450 bar (45 MPa)* (ref. Subclause 5.4.3)
- [50] ISO 15500-3, *Road vehicles — Compressed natural gas (CNG) fuel system components — Part 3: Check valve* (ref. Subclauses 5.4 and 5.4.7)
- [51] ISO 15761, *Steel gate, globe and check valves for sizes DN 100 and smaller, for the petroleum and natural gas industries* (ref. Subclauses 5.4 and 5.4.7)
- [52] ISO/TS 20100, *Gaseous hydrogen — Fuelling stations*
- [53] NASA NSS 1740.15, *Safety Standard for Oxygen and Oxygen Systems* (ref. Subclause 4.5)
- [54] SAE ARP 5580, *Recommended Failure Modes and Effects Analysis (FMEA) Practices for Non-Automobile Applications*
- [55] UL 429, *Electrically Operated Valves* (ref. Subclause 5.4.7)
- [56] UL 507, *Electric Fans* (ref. Subclause 5.7)
- [57] UL 842, *Valves for Flammable Fluids* (ref. Subclause 5.9)
- [58] UL 1469, *Strength of Body and Hydraulic Pressure Loss Testing of Backflow Special Check Valves* (ref. Subclause 5.9)

© 2010 International Organization for Standardization

.....

ICS 71.100.20; 71.120.99

Price based on 44 pages