

---

---

**Footwear — Test methods for insoles  
and insocks — Water absorption and  
desorption**

*Chaussures — Méthodes d'essai applicables aux premières de montage  
et aux premières de propreté — Absorption et désorption d'eau*



**COPYRIGHT PROTECTED DOCUMENT**

© ISO 2016, Published in Switzerland

All rights reserved. Unless otherwise specified, no part of this publication may be reproduced or utilized otherwise in any form or by any means, electronic or mechanical, including photocopying, or posting on the internet or an intranet, without prior written permission. Permission can be requested from either ISO at the address below or ISO's member body in the country of the requester.

ISO copyright office  
Ch. de Blandonnet 8 • CP 401  
CH-1214 Vernier, Geneva, Switzerland  
Tel. +41 22 749 01 11  
Fax +41 22 749 09 47  
copyright@iso.org  
www.iso.org

# Contents

Page

<b>Foreword</b> .....	<b>iv</b>
<b>1 Scope</b> .....	<b>1</b>
<b>2 Normative references</b> .....	<b>1</b>
<b>3 Terms and definitions</b> .....	<b>1</b>
<b>4 Apparatus and material</b> .....	<b>1</b>
4.1 Method A .....	1
4.2 Method B .....	2
<b>5 Sampling and conditioning</b> .....	<b>3</b>
5.1 Method A .....	3
5.2 Method B .....	4
<b>6 Test method</b> .....	<b>4</b>
6.1 Method A .....	4
6.1.1 Determination of the water absorption .....	4
6.1.2 Determination of the water desorption .....	4
6.2 Method B .....	4
6.2.1 Principle .....	4
6.2.2 Determination of the water absorption .....	4
6.2.3 Determination of the water desorption .....	5
<b>7 Expression of results</b> .....	<b>5</b>
7.1 Method A .....	5
7.1.1 Water absorption .....	5
7.1.2 Water desorption .....	5
7.2 Method B .....	6
7.2.1 Water absorption .....	6
7.2.2 Water desorption .....	6
<b>8 Test report</b> .....	<b>6</b>
8.1 Method A .....	6
8.2 Method B .....	7

## Foreword

ISO (the International Organization for Standardization) is a worldwide federation of national standards bodies (ISO member bodies). The work of preparing International Standards is normally carried out through ISO technical committees. Each member body interested in a subject for which a technical committee has been established has the right to be represented on that committee. International organizations, governmental and non-governmental, in liaison with ISO, also take part in the work. ISO collaborates closely with the International Electrotechnical Commission (IEC) on all matters of electrotechnical standardization.

The procedures used to develop this document and those intended for its further maintenance are described in the ISO/IEC Directives, Part 1. In particular the different approval criteria needed for the different types of ISO documents should be noted. This document was drafted in accordance with the editorial rules of the ISO/IEC Directives, Part 2 (see [www.iso.org/directives](http://www.iso.org/directives)).

Attention is drawn to the possibility that some of the elements of this document may be the subject of patent rights. ISO shall not be held responsible for identifying any or all such patent rights. Details of any patent rights identified during the development of the document will be in the Introduction and/or on the ISO list of patent declarations received (see [www.iso.org/patents](http://www.iso.org/patents)).

Any trade name used in this document is information given for the convenience of users and does not constitute an endorsement.

For an explanation on the meaning of ISO specific terms and expressions related to conformity assessment, as well as information about ISO's adherence to the WTO principles in the Technical Barriers to Trade (TBT) see the following URL: [Foreword - Supplementary information](#)

ISO 22649 was prepared by the European Committee Standardization (CEN) Technical Committee CEN/TC 309, *Footwear*, in collaboration with ISO Technical Committee TC 216, *Footwear*, in accordance with the agreement on technical cooperation between ISO and CEN (Vienna Agreement).

This second edition cancels and replaces the first edition (ISO 22649:2003), which has been technically revised.

# Footwear — Test methods for insoles and insocks — Water absorption and desorption

## 1 Scope

This International Standard specifies two test methods for determining the water absorption and desorption of insoles and insocks, irrespective of the material.

These methods are as follows.

- Method A: Determination of the static water absorption and desorption of insoles and insocks.
- Method B: Determination of the dynamic water absorption and desorption of insoles and insocks.

## 2 Normative references

The following documents, in whole or in part, are normatively referenced in this document and are indispensable for its application. For dated references, only the edition cited applies. For undated references, the latest edition of the referenced document (including any amendments) applies.

ISO 17709, *Footwear — Sampling location, preparation and duration of conditioning of samples and test pieces*

ISO 18454, *Footwear — Standard atmospheres for conditioning and testing of footwear and components for footwear*

## 3 Terms and definitions

For the purposes of this document, the following terms and definitions apply.

### 3.1

#### **water absorption**

gain in mass per area unit of the test piece due to water absorption during one or more specified periods of time

### 3.2

#### **water desorption**

percentage loss in mass of the test piece, expressed in terms of the mass of water absorbed

### 3.3

#### **surface**

visible site of the material during the use at the shoe

## 4 Apparatus and material

The following apparatus and material shall be used.

### 4.1 Method A

**4.1.1 Laboratory balance**, with an accuracy of 0,001 g.

**4.1.2 Square knife**, to cut a test piece of  $(50 \pm 1)$  mm  $\times$   $(50 \pm 1)$  mm. The inner surface of the knife shall be angled outward from the cutting edge at approximately  $5^\circ$  to the vertical so that when the test piece is cut, the knife passes through it without damage to the test piece edge.

**4.1.3 Filter paper.**

**4.1.4 Distilled water.**

**4.1.5 Beaker or recipient**, with flat bottom and suitable dimensions.

**4.1.6 Vernier calipers**, capable of measuring to an accuracy of 0,2 mm.

## 4.2 Method B

**4.2.1 Apparatus** (as indicated in [Figure 1](#)) composed of the following.

**4.2.1.1 Brass roller** (A), of diameter  $(120 \pm 1)$  mm and width  $(50 \pm 1)$  mm, which is placed over the test piece (B).

**4.2.1.2 Platform** (C) is covered, with a roughened upper surface and with sufficient perforations to allow the surface to be kept wet by a flow of water through the platform. The upper surface of the platform (C) is covered, by a strip of cotton gauze.

**4.2.1.3 Clamp** (D), to hold one short side of the test piece (B) in a horizontal position on the platform (C).

**4.2.1.4 Clamp** (E), to attach the other short side of the test piece to the roller with the attached side being parallel to the axis of the roller.

The clamp is held by a weak spring to maintain the sample under slight tension.

**4.2.1.5 Water supply** (F), through the platform (C) and a means of draining away excess water.

**4.2.1.6 Means** of moving the axis of the roller, with a *to-and-fro* motion along the X-X-axis, with an amplitude of  $(50 \pm 2)$  mm about a point directly over the mid point of the test piece and frequency of  $(20 \pm 1)$  cycles per minute.

The movement of the axis causes the roller to move backwards and forwards along the test piece, raising one end and bending it to conform to the shape of the roller.

4.2.1.7 **Means** of pressing the platform, test piece and roller together with a force of  $(80 \pm 5)$  N.

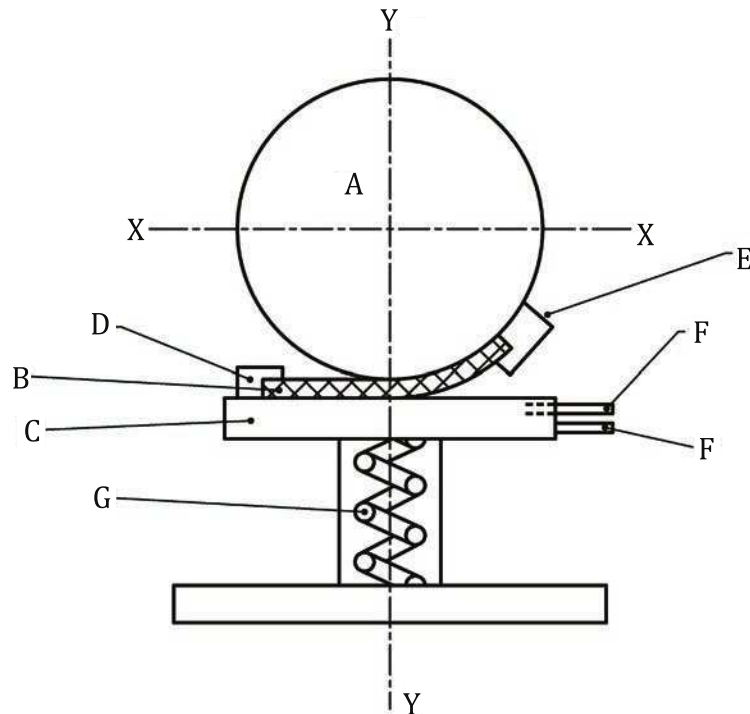

**Key**

A	brass roller	B	test piece	C	platform	D	clamp
E	clamp	F	water supply	G	spring		

**Figure 1 — Device for measuring water absorption and desorption**

4.2.2 **Press knife**, to cut test pieces of dimensions  $(110 \pm 1)$  mm  $\times$   $(40 \pm 1)$  mm.

4.2.3 **Balance**, reading to 0,001 g.

4.2.4 **Clock**, reading to 1 s.

4.2.5 **Silicone grease**.

## 5 Sampling and conditioning

### 5.1 Method A

Using the square knife described in 4.1.2, cut a test piece of dimensions  $(50 \pm 1)$  mm  $\times$   $(50 \pm 1)$  mm from the shoe insole or insock, cut insole or insock, or from the components as supplied. If the test pieces are taken from the shoe or from the cut components, sampling shall be done in accordance with ISO 17709.

Condition the test pieces according to ISO 18454, for a minimum of 24 h.

Minimum two test pieces are necessary.

## 5.2 Method B

**5.2.1** In the case of footwear, the test pieces should be taken from the forepart of the insole or insock, in the longitudinal sense. For sheet materials, the test pieces shall be taken in the two principal directions, one at 90° to the other. Minimum two test pieces are necessary.

**5.2.2** Test specimens are strips of  $(110 \pm 1)$  mm  $\times$   $(40 \pm 1)$  mm and shall be placed in a conditioned atmosphere as specified in ISO 18454 for 24 h prior to the test.

**5.2.3** Apply a little silicone grease over the edges of the test piece in order to prevent the ingress of water through the sides.

## 6 Test method

### 6.1 Method A

#### 6.1.1 Determination of the water absorption

Measure (4.1.6) the length and the width of the test piece in millimetres to the nearest 0,2 mm. Calculate the area,  $A$ , in square metres.

Weigh the test piece (4.1.1) to the nearest 0,001 g, and record its mass,  $M_0$ .

Place the test piece in distilled water conditioned according to ISO 18454 for 6 h. Then, remove it, dry off any remaining drops of water using filter paper and reweigh it, recording its mass,  $M_F$ .

The temperature of the test shall be  $(20 \pm 2)$  °C.

#### 6.1.2 Determination of the water desorption

On completion of the test specified in 6.1.1, condition the test piece for 16 h according to ISO 18454 and then reweigh it (4.1.1), recording its mass,  $M_R$ .

### 6.2 Method B

#### 6.2.1 Principle

A test piece is positioned on a wet base plate and is submitted to repeat flexing under a given pressure (in the same manner as the insole of a shoe during walking).

#### 6.2.2 Determination of the water absorption

**6.2.2.1** Weigh the piece to the nearest 0,001 g ( $M_0$ ).

**6.2.2.2** Place the cotton gauze on the platform (C).

**6.2.2.3** Apply the test piece in the apparatus with the surface which would be in contact with the foot, in contact with platform (C) covered with the cotton gauze. Attach the narrow ends to the platform and roller, apply a force of  $(80 \pm 5)$  N.

**6.2.2.4** Open the valve for the arrival of water and adjust a flow of water of 7,5 ml/min over the platform.

**6.2.2.5** Switch on the machine and note the time.



**6.2.2.6** After a suitable period (15 min), stop the water supply 1 min before stopping the machine.

**6.2.2.7** Remove the test piece and weigh it to the nearest 0,001 g.

**6.2.2.8** Replace the test piece in the apparatus, open the water valve and continue the test. The test time is 8 h.

**6.2.2.9** If the test piece is removed before the 8 h period because the test specimen reaches saturation, remove and keep it in a plastic bag long enough to accomplish the night drying time (16 h) established in [6.2.3](#).

### 6.2.3 Determination of the water desorption

Recondition the test piece in a standard controlled environment specified in ISO 18454 for a period of 16 h, then reweigh the test piece to the nearest 0,001 g ( $M_R$ ).

## 7 Expression of results

### 7.1 Method A

#### 7.1.1 Water absorption

Calculate the water absorption,  $W_A$ , expressed in grams per square metre using Formula (1).

$$W_A = \frac{M_F - M_O}{A} \quad (1)$$

where

$M_O$  is the initial mass of the test piece, i.e. in its dry condition, in grams;

$M_F$  is the final mass of the test piece, i.e. in its wet condition, in grams;

$A$  is the area of the test piece, in square metres.

Express the water absorption to the nearest 1 g/m<sup>2</sup>.

The result will be the average of the two results.

#### 7.1.2 Water desorption

Calculate the water desorption,  $W_D$ , as a percentage of mass using Formula (2).

$$W_D = \frac{M_F - M_R}{M_F - M_O} \times 100 \quad (2)$$

where

$M_O$  is the initial mass of the test piece, in grams;

$M_F$  is the final mass of the test piece, in grams;

$M_R$  is the mass of the reconditioned test piece, in grams.

Report the water desorption to the nearest 1 %.

## 7.2 Method B

### 7.2.1 Water absorption

Calculate the water absorption,  $W_A$ , expressed in grams per square metre using Formula (3).

$$W_A = \frac{M_F - M_O}{A} \quad (3)$$

where

$M_O$  is the initial mass of the test piece, in grams;

$M_F$  is the final mass of the test piece, in grams;

$A$  is the area of the test piece, in square metres.

Express the water absorption to the nearest 1 g/m<sup>2</sup>.

### 7.2.2 Water desorption

Calculate the water desorption,  $W_D$ , as a percentage of the mass of water absorbed using Formula (4).

$$W_D = \frac{M_F - M_R}{M_F - M_O} \times 100 \quad (4)$$

where

$M_O$  is the initial mass of the test piece, in grams;

$M_F$  is the final mass of the test piece, in grams;

$M_R$  is the mass of the reconditioned test piece, in grams.

Report the water desorption to the nearest 1 %.

## 8 Test report

### 8.1 Method A

The test report shall include the following information:

- a) a reference to this International Standard, ie. ISO 22649;
- b) the results for water absorption and water desorption, expressed in accordance with [7.1.1](#) and [7.1.2](#);
- c) the nature and full identification of the sample;
- d) a description of sampling procedure, where relevant;
- e) a reference to the test method;
- f) the details of any deviation from the standard test procedure;
- g) the date of testing.

## 8.2 Method B

The test report shall include the following information:

- a) a reference to this International Standard, ie. ISO 22649;
- b) the results for water absorption and water desorption, expressed in accordance with [7.2.1](#) and [7.2.2](#);
- c) the nature and full identification of the sample;
- d) a description of sampling procedure, where relevant;
- e) a reference to the test method;
- f) the details of any deviation from the standard test procedure;
- g) the date of testing.

