**Crop protection equipment — Field
measurement of spray distribution in tree
and bush crops**

*Matériel de protection des cultures — Mesurage au champ de la
répartition de la pulvérisation pour arbres et arbustes fruitiers*



Reference number
ISO 22522:2007(E)

PDF disclaimer

This PDF file may contain embedded typefaces. In accordance with Adobe's licensing policy, this file may be printed or viewed but shall not be edited unless the typefaces which are embedded are licensed to and installed on the computer performing the editing. In downloading this file, parties accept therein the responsibility of not infringing Adobe's licensing policy. The ISO Central Secretariat accepts no liability in this area.

Adobe is a trademark of Adobe Systems Incorporated.

Details of the software products used to create this PDF file can be found in the General Info relative to the file; the PDF-creation parameters were optimized for printing. Every care has been taken to ensure that the file is suitable for use by ISO member bodies. In the unlikely event that a problem relating to it is found, please inform the Central Secretariat at the address given below.

© ISO 2007

All rights reserved. Unless otherwise specified, no part of this publication may be reproduced or utilized in any form or by any means, electronic or mechanical, including photocopying and microfilm, without permission in writing from either ISO at the address below or ISO's member body in the country of the requester.

ISO copyright office
Case postale 56 • CH-1211 Geneva 20
Tel. + 41 22 749 01 11
Fax + 41 22 749 09 47
E-mail copyright@iso.org
Web www.iso.org

Published in Switzerland

Contents

Page

Foreword	iv
1 Scope	1
2 Normative references	1
3 Terms and definitions	1
4 Elements of a test	2
5 Trial design	2
6 Description of sprayer settings	2
7 Description of tree or bush orchard	6
8 Description of the spray liquid	6
9 Sampling	6
9.1 General	6
9.2 Canopy targets	7
9.3 Ground targets	11
10 Measurement of meteorological conditions	13
11 Conditions for comparative measurements	13
Annex A (normative) Tracers	14
Annex B (informative) Artificial target description	15
Annex C (informative) Sampling methodology	16
Annex D (informative) Collectors for measuring spray loss to ground	17
Annex E (informative) Presentation of results	18
Bibliography	19

Foreword

ISO (the International Organization for Standardization) is a worldwide federation of national standards bodies (ISO member bodies). The work of preparing International Standards is normally carried out through ISO technical committees. Each member body interested in a subject for which a technical committee has been established has the right to be represented on that committee. International organizations, governmental and non-governmental, in liaison with ISO, also take part in the work. ISO collaborates closely with the International Electrotechnical Commission (IEC) on all matters of electrotechnical standardization.

International Standards are drafted in accordance with the rules given in the ISO/IEC Directives, Part 2.

The main task of technical committees is to prepare International Standards. Draft International Standards adopted by the technical committees are circulated to the member bodies for voting. Publication as an International Standard requires approval by at least 75 % of the member bodies casting a vote.

Attention is drawn to the possibility that some of the elements of this document may be the subject of patent rights. ISO shall not be held responsible for identifying any or all such patent rights.

ISO 22522 was prepared by Technical Committee ISO/TC 23, *Tractors and machinery for agriculture and forestry*, Subcommittee SC 6, *Equipment for crop protection*.

.....

Crop protection equipment — Field measurement of spray distribution in tree and bush crops

1 Scope

This International Standard is applicable to the field measurement of quantities of spray deposit, applied using ground sprayers, on tree and bush crops.

It covers measurements of the volume or mass of spray deposits (both absolute and distribution) on target structures such as leaves, fruits and ground losses.

It does not deal with spray drift measurements. However, its use in combination with the protocol for field measurements of spray drift given in ISO 22866 can result in a good evaluation of spray mass balance in tree or bush spraying when measuring airborne drift.

This International Standard allows for flexibility in the arrangement of field tests, specifying standardized measurement procedures that are useful for comparison of the results from different field experiments or laboratory tests, for example, using a vertical patternator.

2 Normative references

The following referenced documents are indispensable for the application of this document. For dated references, only the edition cited applies. For undated references, the latest edition of the referenced document (including any amendments) applies.

ISO 9898, *Equipment for crop protection — Test methods for air-assisted sprayers for bush and tree crops*

ISO 10627-1, *Agricultural sprayers — Data sheet — Part 1: Typical layout*

ISO 10627-2, *Hydraulic agricultural sprayers — Data sheets — Part 2: Technical specifications related to components*

3 Terms and definitions

For the purposes of this document, the following terms and definitions apply.

3.1

plot

one or several adjacent rows to be sprayed

3.2

tracer

traceable material representing a plant protection product formulation

4 Elements of a test

A spray distribution test comprises the application of a tracer to the canopies by travelling at a measured forward speed along defined tracks, and the measurement of spray deposit on the target canopy (leaves and/or fruits), if available and/or appropriate structures (artificial targets), to determinate the spray cover and collectors for the measurement of ground losses.

An appropriate tracer in a water solution may be used for field measurements. Where possible, all measurements shall use a tracer of low toxicity that can be safely applied with no associated risks of environmental contamination. The spray liquid shall have physical properties representative of liquids typically used in the application of plant protection products. Other products that can be added to more closely mimic an actual pesticide solution, such as surfactants, should be described in the test report.

Tracers that allow several applications on the same target can be used to decrease variability attributable to structural changes within the sampled biological targets.

5 Trial design

The plots shall be located inside a uniform, representative and well cared for orchard.

In order to prevent interactions with other treatments and/or edge effect, at least two further rows of trees or bushes shall be present on each side of the plot.

An appropriate length of rows shall be sprayed, on one or both sides. This length shall ensure the output of the intended spray volume over the plot.

Details of the spraying layout shall be fully reported within the results.

6 Description of sprayer settings

At least the following items shall be described.

a) Sprayer:

- manufacturer;
- type and model;
- travel speed (km/h);
- overall liquid flow rate (l/min).

b) Nozzles and liquid distribution:

- one side (left or right) or two-sided application;
- working pressure (MPa);
- nozzles characteristics and positions (see Table 1 and Figure 1);
- position of nozzles in relation to the air stream (in or out);
- nozzle flow direction (front, central or rear);
- droplet size data (D_{v10} , D_{v50} , D_{v90}) for hydraulic nozzles (including the measuring system).

c) Air flow distribution (for air-assisted sprayers):

- fan type;
- gear position;
- PTO (power take off) speed (min^{-1});
- rotation direction – clockwise or anticlockwise (counter-clockwise);
- deflector characteristics (air-directional) description according to ISO 10627-1 and ISO 10627-2 (see Table 2 and Figure 2);
- air speed and airflow rate of the sprayer according to ISO 9898.

The liquid and air distribution system of the sprayer shall be described using diagrams, pictures and/or photographs in the test report.

If possible, in order to better explain test results obtained from different types of sprayers, it would be preferable also to refer to the vertical spray pattern, measured using a vertical test bench (see ISO 9898).

Table 1 — Nozzle characteristics and position

Left			Nozzle no.	Right		
Model	Measured flow rate l/min	Height Distance to row axis Orientation ^a cm cm degree		Model	Measured flow rate (l/min)	Height Distance to row axis Orientation ^a cm cm degree
		e.g. 150 225 22	1			e.g. 150 225 22
			2			
			<i>n</i>			
Total flow rate				Total flow rate		

^a Angle of orientation, *a*, related to the horizontal level (example of axial fan sprayer). See Figure 1.

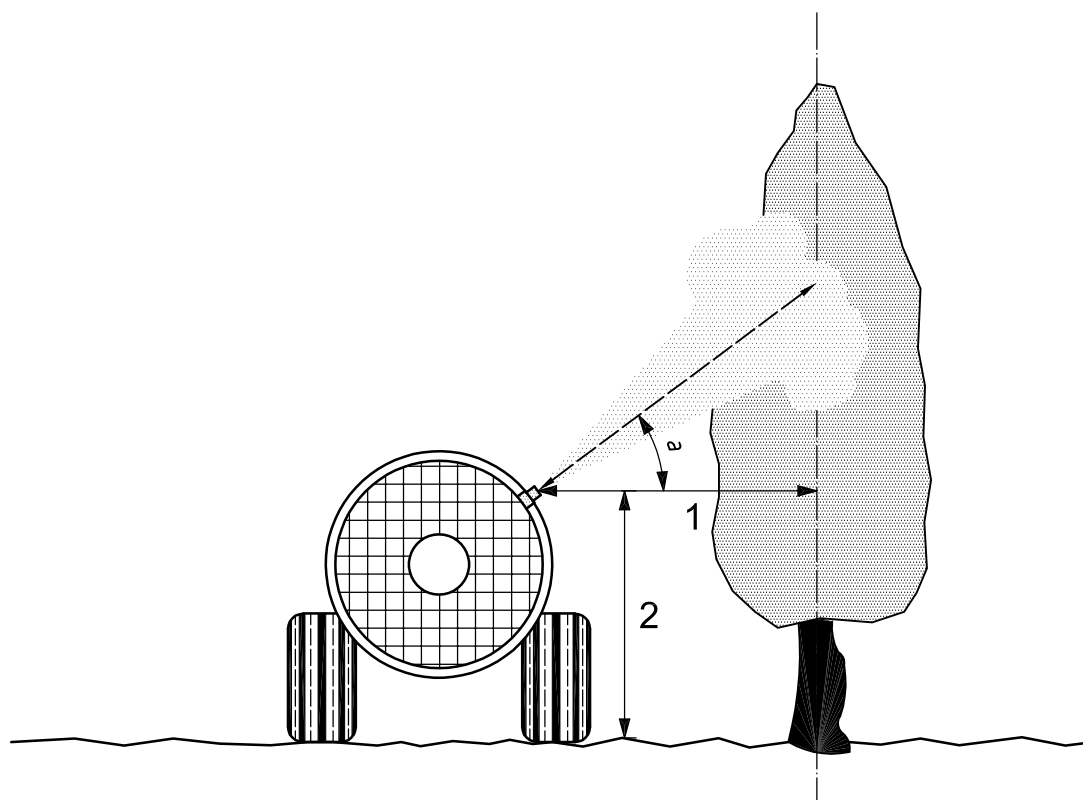

Key

- a* angle of orientation related to horizontal level (example of axial fan sprayer)
- 1 distance to row axis
- 2 height

Figure 1 — Nozzle position

Table 2 — Deflector characteristics

Left			Nozzle no.	Right		
Position	Length cm	Height Distance to row axis Orientation ^a cm cm degrees		Position	Length cm	Height Distance to row axis Orientation ^a cm cm degrees
e.g. upper	e.g. 25	e.g. 10 200 45	1	e.g. upper	e.g. 25	e.g. 185 200 30
			2			
			<i>n</i>			

^a Angle of orientation, *b*, related to the horizontal level (example of axial fan sprayer). See Figure 2.

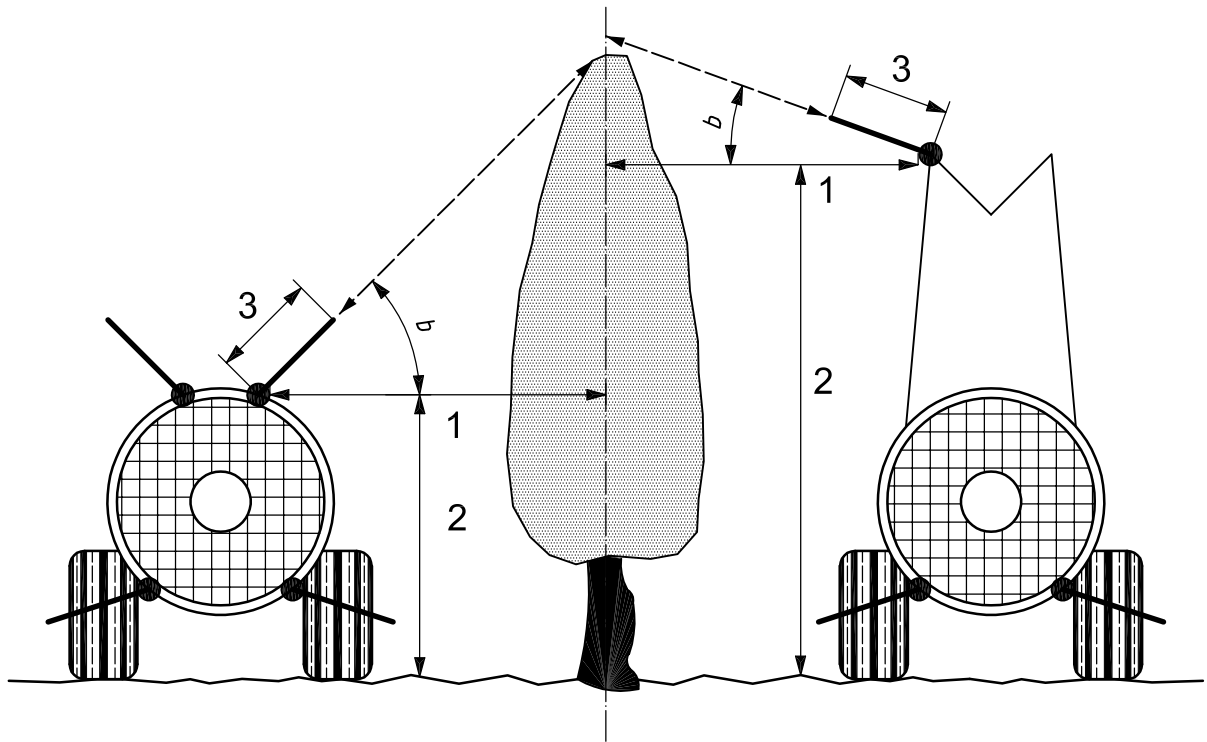

Key

- b* angle of orientation related to horizontal level (example of axial fan sprayer)
- 1 distance to row axis
- 2 height
- 3 length

Figure 2 — Deflector position

7 Description of tree or bush orchard

The description of the tree or bush orchard shall include at least the following information:

- a) crop, variety and rootstock;
- b) age (years);
- c) training system (pruning type);
- d) phenological stage in the trial date (growth stage), if available, using code standards;
- e) parametric dimensions (average volume or mass measurements), comprising
 - average distance between rows (m),
 - average distance between trees or bushes in the row (m) (describe positions by means of diagrams, if necessary),
 - average height (cm),
 - average vegetation width (cm), geometry, shape, gaps, number of layers, and
 - average vegetation volume per unit area;
- f) mass measurements (optional, however, if done, the methodology shall be described) consisting of
 - leaf area index (one-sided green leaf area per unit ground area), and
 - leaf density (one-sided green leaf area in a defined volume within the canopy).

8 Description of the spray liquid

The description of the spray liquid shall include at least the following information:

- tracers, adjuvants, chemical used, with description and concentration reported (see Annex A);
- sprayed dose (liquid, tracer, adjuvant);
- tracer concentration, with representative samples of the spray mixture liquid taken for immediate analysis before and/or after spraying.

If different tracers are used in the same experiment, they shall be allocated at random to each application.

9 Sampling

9.1 General

Depositions are measured using at least three replications within the plot.

In each replication, at least one tree or bush shall be chosen on which to carry out the measurements of spray deposit on the defined targets (leaves or fruits). To prevent “start-up” and “finishing” effects, an appropriate number of trees or bushes shall be ignored in both ends of the rows. This shall be noted in the report.

Before treatment application commences, several replicate blank samples shall be taken so that the pre-spraying amounts of the used tracers (expected to be near zero) can be determined.

A profile sampling strategy (see 9.2.1) or a zone sampling strategy (see 9.2.2) shall be adopted. Optionally, it could be interesting to use both sampling strategies in order to obtain the advantages of both methods. Additional strategies shall be fully reported.

In order to minimize experimental error, the samples shall be taken, stored, extracted and analysed in a suitable way, depending on the tracer used. For instance, it is always important to take the samples as soon as the spray deposit of last application has dried. Also, when using fluorescent tracers, it is important to store samples in dark boxes and, when using metal tracers, it is recommended that leaf sweating be avoided by the use of appropriate bags or by refrigeration of the samples just after collection.

Artificial targets can be used to help the adjusting process of the sprayer or in carrying out preliminary tests. A description of their number, position, material, attaching system and other relevant details shall be provided (see Annex B).

Procedures for handling samples or collectors prior to and post exposure to spray that minimize the risk of cross-contamination shall be established. The potential for cross-contamination and tracer degradation shall be monitored during a trial using clean samples or collectors and those loaded with a measured volume of the tracer solution.

After use, samples or collectors shall be stored for the minimum period possible. The storage shall be in conditions appropriate to the tracer, typically dry, in darkness, and at a temperature of less than 4 °C, minimizing any risk of condensation (since this can result in inaccuracy).

In all cases, measures to prevent samples degradation shall be employed.

Deposits on samples or collectors should be calculated based on the calibration of the tracing technique with samples of the spray liquid taken from a nozzle at the time of the spraying.

9.2 Canopy targets

9.2.1 Profile sampling strategy

A profile sampling strategy is useful when measuring the vertical distribution of tracer in the canopy because it provides information on precise deposition on single leaves along the profile. This strategy brings more variability to the test due to measurements on single leaves, but generates a large amount of samples, making tests more time-consuming and expensive.

Samples represent single target points distributed in levels separated by a maximum of 25 cm [see Figure 3 a)]. In every tree or bush, samples shall be collected following different profiles in the vegetation [see Figure 3 b)]. If the canopy width, in the tangential direction of the sprayer displacement, is less than 50 cm, two peripheral profiles (A and B) shall be followed to collect samples placed on the sides of the tree facing the alleys. If the canopy is greater than or equal to 50 cm wide, at least one further profile (C) shall be added in the middle (central) part of the tree, around the trunk.

One additional profile (D) shall be considered when the maximum overlapped width is lower than half the maximum width of the trees ($a < b/2$) [see Figure 3 b)]. Two additional peripheral profiles (D and E) shall be considered when trees are isolated. These profiles shall be placed in the vertical plane, including the row axle, with one at the beginning of the tree and the other one at the end of the tree.

At least one sample shall correspond to an individual leaf or fruitlet along the profiles. If this is not possible, the solutions adopted shall be reported. The positions of the different sample points shall be reported (see Annex C).

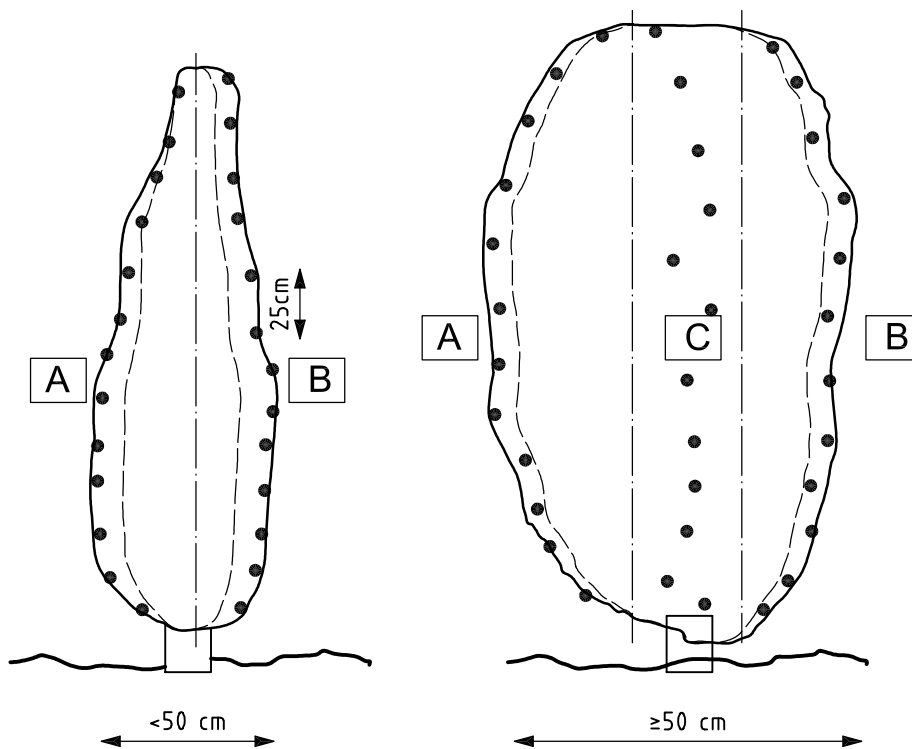

a) Sample collection in vertical plane

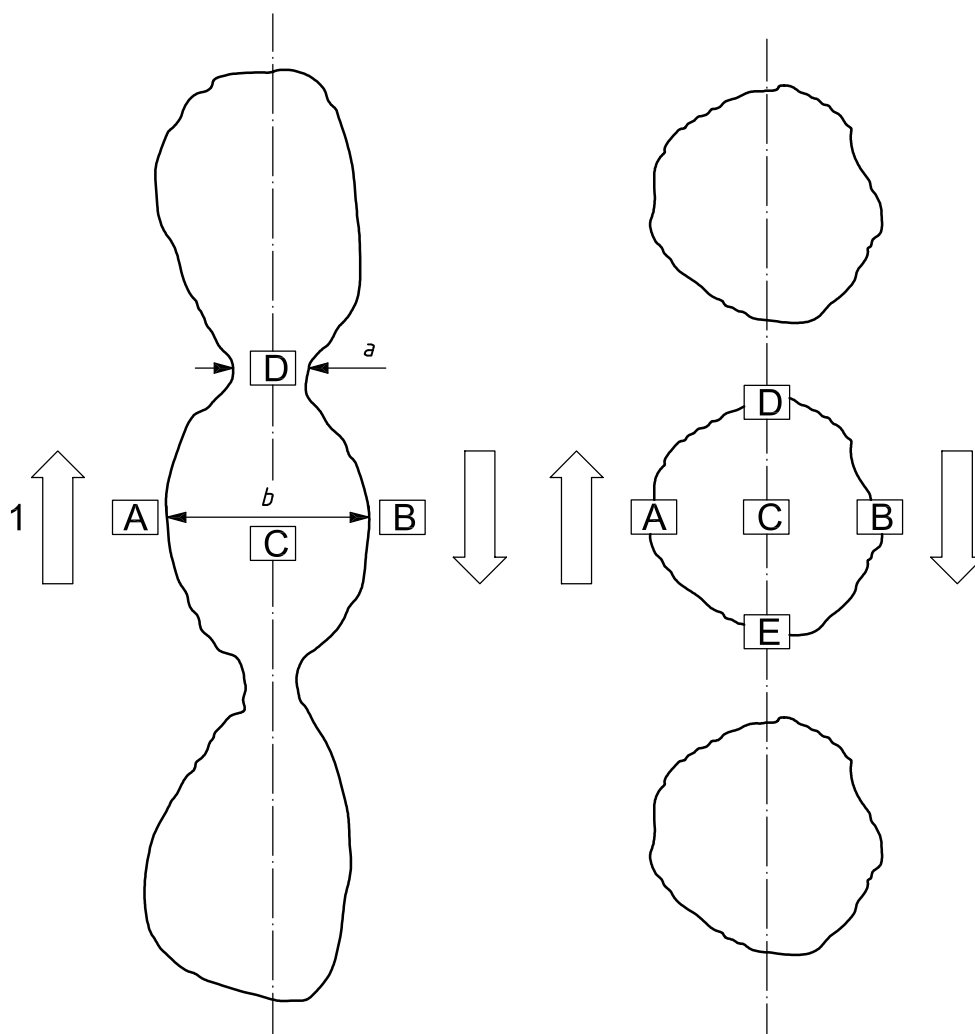

b) Sample collection in horizontal plane

Key

A, B, C, D, E peripheral profiles

1 sprayer track

a maximum overlapped width

b maximum width of trees

Figure 3 — Profile sampling strategy

9.2.2 Zone (volume) sampling strategy

A zone sampling strategy is useful for determining an overall distribution of tracer in the vegetation in that it represents a large amount of leaf surface and generates less samples than the profile strategy. It carries a loss of information by “physically” averaging leaf deposits in the same sample.

Information about spray deposits on the targets are less detailed than in the profile sampling strategy (wider intervals between sampling points) and a physical delimitation of the zones for the sampling operations is needed.

Samples represent zones or vegetation volumes into which the canopy has been divided. Regarding the height of the tree or bush, horizontal zones shall be defined at different levels [see Figure 4 a)] up to a maximum height of 1 m.

In every tree or bush, samples shall be collected from different zones in the vegetation. If the canopy width is less than 50 cm, it shall be divided into two vertical zones (left and right). If the width of the canopy is greater than or equal to 50 cm, at least one additional zone per side shall be added to the central part of the tree around the trunk. The depth of vertical zones shall be a quarter of the total tree width [see Figure 4 b) i)].

When testing isolated trees, vertical zones shall be distributed as shown in Figure 4 b) ii).

Samples in this strategy shall be a cluster of leaves or fruitlets. The number of leaves or fruitlets of each sample shall be such as to allow a representative random sampling from the whole zone. The positions and the number of leaves or fruitlets of the different sample zones shall be reported (see Annex C).

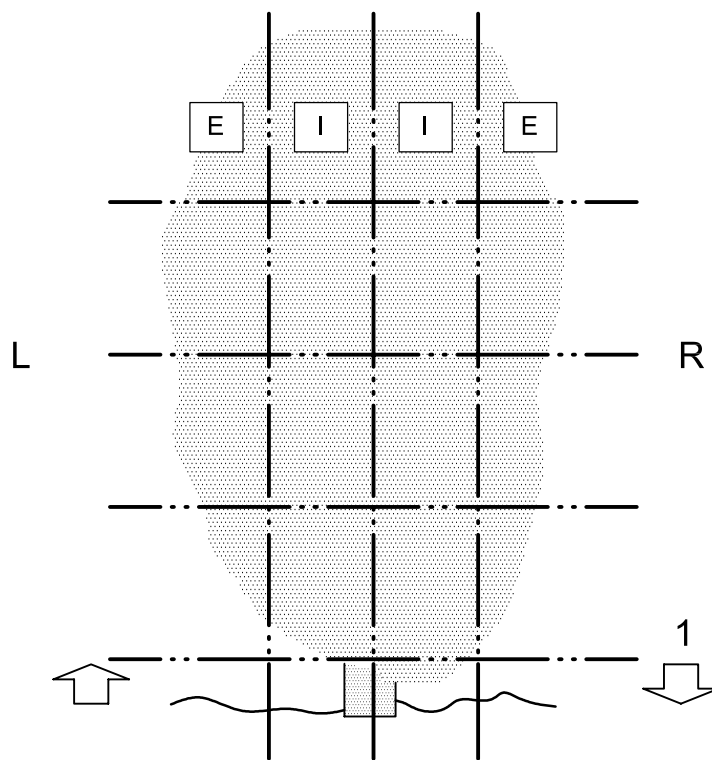

a) Sample collection in vertical plane

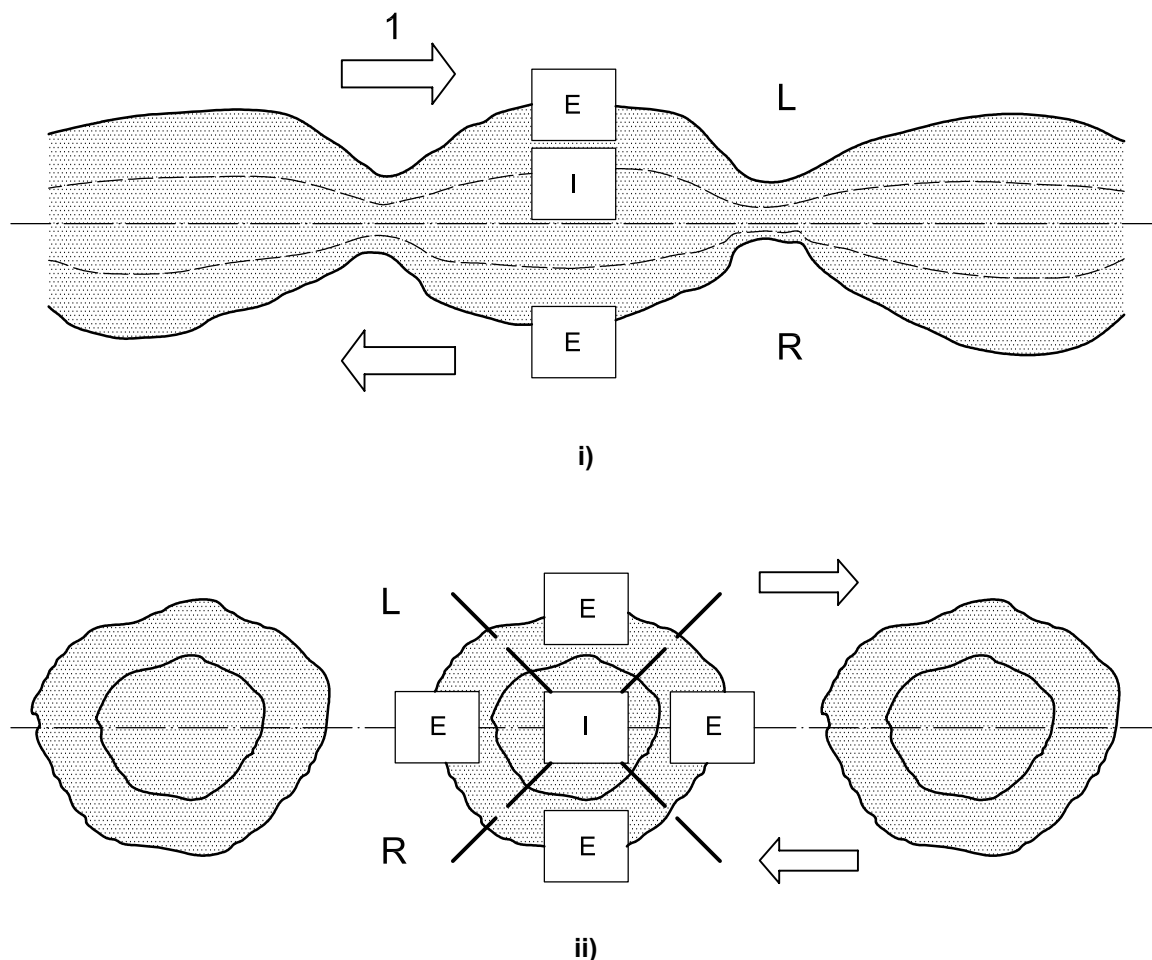

b) Sample collection in horizontal plane

Key

- E exterior
- I interior
- L left
- R right
- 1 sprayer track

Figure 4 — Zone sampling strategy

9.3 Ground targets

In all plots as defined in Clause 5, horizontal flat collectors of a collecting surface greater than or equal to 500 cm² shall be used to measure spray deposit on the ground. Samples shall be representative of ground deposit. At least four alleys shall be considered: two on each side of the treated row. In each alley, samples shall be collected in at least three positions.

Collectors shall be positioned in two lines, perpendicular to rows: one at the trunk level (below the trees) and the other in the central position between trunks, as shown in Figure 5. Two possibilities are shown in Figure 5: a canopy width of less than 50 cm [see Figure 5 a)] and a canopy width greater than or equal to 50 cm [see Figure 5 b)].

A description of number, position, material of collectors and other relevant details shall be provided (see Annex D).

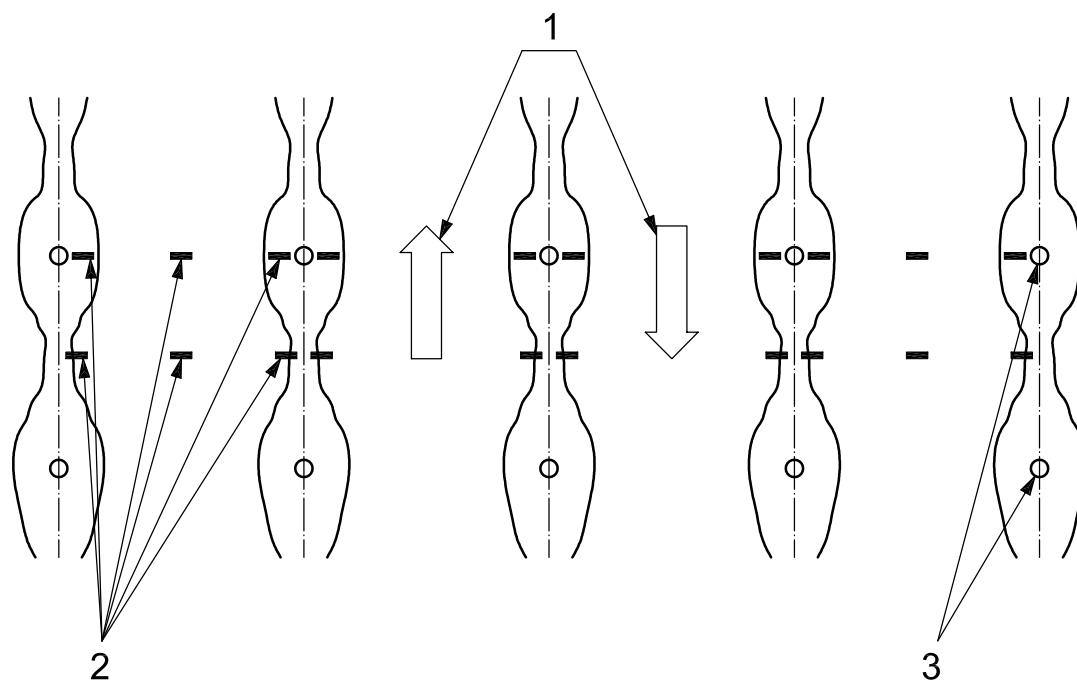

a) Narrow trees (canopy width < 50 cm)

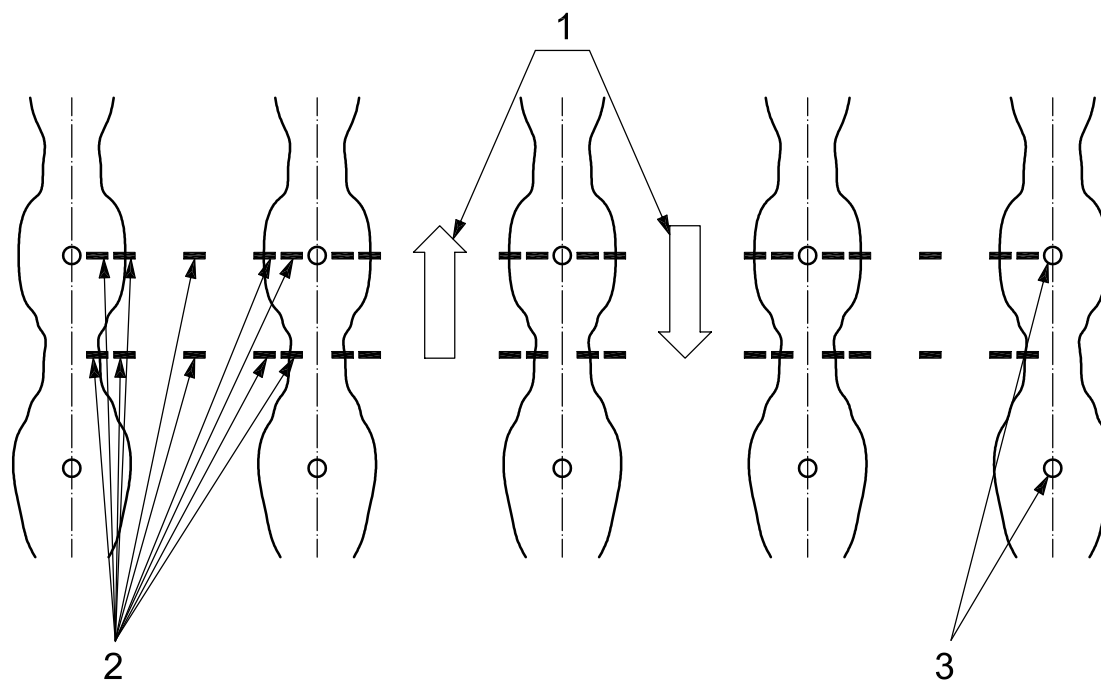

b) Wide trees (canopy width \geq 50 cm)

Key

- 1 sprayer track
- 2 collector
- 3 tree trunk

Figure 5 — Ground sampling layout for sampling area

10 Measurement of meteorological conditions

Measurement of the meteorological conditions at the time of the test shall be made at the centre of the orchard. The meteorological mast shall be placed in the centre of an alley which is beyond the influence of the sprayer.

The following measurements are to be made with the stated accuracy:

- wind velocity (0,2 m/s), sensor placed 1 m above the top of the canopies;
- wind direction (5°), sensor placed 1 m above the top of the canopies;
- temperature (0,5 °C);
- relative humidity (5 %).

11 Conditions for comparative measurements

- Wind speed: ± 25 % deviation between the tests being compared.
- Wind direction: ± 10 % deviation between the tests being compared.
- Temperature: ± 5 % deviation between the tests being compared.
- Relative humidity: ± 10 % deviation between the tests being compared.
- To calculate wet bulb depression: ± 2 °C deviation between the tests being compared.

The instruments shall be calibrated prior to making the measurements.

© ISO 2007. All rights reserved.

Annex A (normative)

Tracers

Tracers have to be stable under field conditions, with a good recovery from all the targets used in the trial. They shall be safe to the users, consumers of any crop and the environment.

Types of tracers to be used:

- metal ions (particularly recommended when making several applications to the same target);
- food dyes (e.g. Tartrazine);
- fluorescent dyes (e.g. BSF, blue dye).

An additional tracer can be used for estimating the fraction of the spray deposits that are recovered from the samples taken.

The recovery and stability of each tracer on the target sample or collector shall be verified prior to the start of the spray deposition measurement. Such preliminary work shall define the level of resolution of the techniques to be employed. Details of all analytical procedures shall be documented.

Annex B (informative)

Artificial target description

The description of the artificial targets shall include at least the following items:

- structure of collectors, material, dimension;
- position (diagram, scheme);
- statistical aspects.

Annex C (informative)

Sampling methodology

The description of the sampling methodology shall include at least the following items:

- profile strategy/zone (volume) strategy;
- position of samples (diagram);
- number of leaves per sample;
- statistical aspects.

.....

Annex D (informative)

Collectors for measuring spray loss to ground

Types of collectors which can be used:

- filter paper;
- acetate sheets;
- aluminium foil;
- plastic sheets;
- Petri dishes.

Annex E (informative)

Presentation of results

Test reports shall include at least the following items:

- sprayer, crop and meteorological conditions;
- measured spray deposit values on the target structures used, such as the canopy and on the ground.

Values of the measured spray deposits are expressed as the amount of spray per unit leaf area. Collector surface is determined if necessary. Normalization to a given application rate shall be required to compare between different application conditions. Therefore, the tracer concentration in the sprayed liquid has to be measured by taking samples out of the nozzle outlet before and after each treatment series.

The uniformity of the spray deposit values that have been recovered from the canopy is reported as the coefficient of variation (CV) of the measured spray deposition values.

Bibliography

- [1] ISO 8909-1:1994, *Forage harvesters — Part 1: Vocabulary*
- [2] ISO 22866, *Equipment for crop protection — Methods for the field measurement of spray drift*

ICS 65.060.40

Price based on 19 pages