**Plastics piping systems for hot and cold
water installations — Polyethylene of
raised temperature resistance (PE-RT) —**

**Part 3:
Fittings**

*Systèmes de canalisations en plastique pour les installations d'eau
chaude et froide — Polyéthylène de meilleure résistance à la
température (PE-RT) —*

Partie 3: Raccords



Reference number
ISO 22391-3:2009(E)

© ISO 2009

PDF disclaimer

This PDF file may contain embedded typefaces. In accordance with Adobe's licensing policy, this file may be printed or viewed but shall not be edited unless the typefaces which are embedded are licensed to and installed on the computer performing the editing. In downloading this file, parties accept therein the responsibility of not infringing Adobe's licensing policy. The ISO Central Secretariat accepts no liability in this area.

Adobe is a trademark of Adobe Systems Incorporated.

Details of the software products used to create this PDF file can be found in the General Info relative to the file; the PDF-creation parameters were optimized for printing. Every care has been taken to ensure that the file is suitable for use by ISO member bodies. In the unlikely event that a problem relating to it is found, please inform the Central Secretariat at the address given below.



COPYRIGHT PROTECTED DOCUMENT

© ISO 2009

All rights reserved. Unless otherwise specified, no part of this publication may be reproduced or utilized in any form or by any means, electronic or mechanical, including photocopying and microfilm, without permission in writing from either ISO at the address below or ISO's member body in the country of the requester.

ISO copyright office
Case postale 56 • CH-1211 Geneva 20
Tel. + 41 22 749 01 11
Fax + 41 22 749 09 47
E-mail copyright@iso.org
Web www.iso.org

Published in Switzerland

Contents

Page

Foreword	iv
Introduction.....	v
1 Scope	1
2 Normative references	1
3 Terms, definitions, symbols and abbreviated terms	2
3.1 General fittings	2
3.2 Mechanical fittings	3
3.3 Fittings for heat fusion.....	3
4 Material characteristics.....	3
4.1 Plastics fitting material	3
4.2 Metallic fitting material.....	5
4.3 Influence on water intended for human consumption	5
5 General characteristics.....	5
5.1 Appearance	5
5.2 Opacity.....	6
6 Geometrical characteristics	6
6.1 General	6
6.2 Dimensions of sockets for socket fusion and electrofusion fittings	6
6.3 Dimensions of metallic fittings	9
7 Mechanical characteristics of plastics fittings.....	10
7.1 General	10
7.2 Fitting material identical to PE-RT compound	10
7.3 Fitting made from PE-RT but not identical to PE-RT compound.....	10
7.4 Fittings made from plastics other than PE-RT	10
8 Physical and chemical characteristics of plastics components	12
8.1 Melt mass flow rate	12
9 Sealing elements	12
10 System performance requirements	12
11 Marking.....	12
11.1 General requirements	12
11.2 Minimum required marking	12
Bibliography.....	14

Foreword

ISO (the International Organization for Standardization) is a worldwide federation of national standards bodies (ISO member bodies). The work of preparing International Standards is normally carried out through ISO technical committees. Each member body interested in a subject for which a technical committee has been established has the right to be represented on that committee. International organizations, governmental and non-governmental, in liaison with ISO, also take part in the work. ISO collaborates closely with the International Electrotechnical Commission (IEC) on all matters of electrotechnical standardization.

International Standards are drafted in accordance with the rules given in the ISO/IEC Directives, Part 2.

The main task of technical committees is to prepare International Standards. Draft International Standards adopted by the technical committees are circulated to the member bodies for voting. Publication as an International Standard requires approval by at least 75 % of the member bodies casting a vote.

Attention is drawn to the possibility that some of the elements of this document may be the subject of patent rights. ISO shall not be held responsible for identifying any or all such patent rights.

ISO 22391-3 was prepared by Technical Committee ISO/TC 138, *Plastics pipes, fittings and valves for the transport of fluids*, Subcommittee SC 2, *Plastics pipes and fittings for water supplies*.

This second edition cancels and replaces the first edition (ISO 22391-3:2007), which is extended from only dealing with PE-RT material (referred to as Type I) to cover PE-RT materials Type I and Type II.

ISO 22391 consists of the following parts¹⁾, under the general title *Plastics piping systems for hot and cold water installations — Polyethylene of raised temperature resistance (PE-RT)*:

- *Part 1: General*
- *Part 2: Pipes*
- *Part 3: Fittings*
- *Part 5: Fitness for purpose of the system*

1) This System Standard does not incorporate a Part 4: Ancillary equipment or a Part 6: Guidance for installation. For ancillary equipment, separate standards can apply. Guidance for installation of plastics piping systems made from different materials, intended to be used for hot and cold water installations, is covered by ENV 12108.

Introduction

The System Standard, of which this is Part 3, specifies the requirements for a piping system and its components when made from polyethylene of raised temperature resistance (PE-RT). The piping system is intended to be used for hot and cold water installations.

In respect of potential adverse effects on the quality of water intended for human consumption caused by the products covered by ISO 22391, the following are relevant.

- a) This part of ISO 22391 provides no information as to whether the products can be used without restriction.
- b) Existing national regulations concerning the use and/or characteristics of the products remain in force.

This part of ISO 22391 specifies the general aspects of the plastics piping system. At the date of publication of this part of ISO 22391, System Standards Series for piping systems of other plastics materials used for the same application are the following:

ISO 15874 (all parts), *Plastics piping systems for hot and cold water installations — Polypropylene (PP)*

ISO 15875 (all parts), *Plastics piping systems for hot and cold water installations — Crosslinked polyethylene (PE-X)*

ISO 15876 (all parts), *Plastics piping systems for hot and cold water installations — Polybutylene (PB)*

ISO 15877 (all parts), *Plastics piping systems for hot and cold water installations — Chlorinated poly(vinyl chloride) (PVC-C)*

Copyright International Organization for Standardization

Plastics piping systems for hot and cold water installations — Polyethylene of raised temperature resistance (PE-RT) —

Part 3: Fittings

1 Scope

This part of ISO 22391 specifies the characteristics of fittings for piping systems made of

- polyethylene of raised temperature resistance (PE-RT), Type I, and
- polyethylene of raised temperature resistance (PE-RT), Type II,

intended to be used for hot and cold water installations within buildings for the conveyance of water, whether or not the water is intended for human consumption (domestic systems) and for heating systems, under the design pressures and temperatures appropriate to the class of application according to ISO 22391-1.

This part of ISO 22391 covers a range of service conditions (classes of application), design pressures and pipe dimension classes, and also specifies test parameters and test methods. In conjunction with the other parts of ISO 22391, it is applicable to fittings made of PE-RT, as well as to those made of other materials, intended to be fitted to pipes conforming to ISO 22391-2 for hot and cold water installations, the joints of which are in accordance with ISO 22391-5.

This part of ISO 22391 is applicable to the following types of fitting:

- mechanical fittings;
- socket fusion fitting;
- electrofusion fittings;
- fittings with incorporated inserts.

It is not applicable to values of design temperature, maximum design temperature or malfunction temperature in excess of those specified in ISO 22391-1.

NOTE It is the responsibility of the purchaser or specifier to make the appropriate selections from these aspects, taking into account their particular requirements and any relevant national regulations and installation practices or codes.

2 Normative references

The following referenced documents are indispensable for the application of this document. For dated references, only the edition cited applies. For undated references, the latest edition of the referenced document (including any amendments) applies.

ISO 7-1, *Pipe threads where pressure-tight joints are made on the threads — Part 1: Dimensions, tolerances and designation*

ISO 22391-3:2009(E)

ISO 228-1, *Pipe threads where pressure-tight joints are not made on the threads — Part 1: Dimensions, tolerances and designation*

ISO 1133-1, *Plastics — Determination of the melt volume-flow rate (MVR) and the melt mass-flow rate (MFR) of thermoplastics — Part 1: Standard method*

ISO 1167-1, *Thermoplastics pipes, fittings and assemblies for the conveyance of fluids — Determination of the resistance to internal pressure — Part 1: General method*

ISO 1167-2, *Thermoplastics pipes, fittings and assemblies for the conveyance of fluids — Determination of the resistance to internal pressure — Part 2: Preparation of pipe test pieces*

ISO 3126, *Plastics piping systems — Plastics components — Determination of dimensions*

ISO 7686, *Plastics pipes and fittings — Determination of opacity*

ISO 9080, *Plastics piping and ducting systems — Determination of long-term hydrostatic strength of thermoplastic materials in pipe form by extrapolation*

ISO 23711, *Elastomeric seals — Requirements for materials for pipe joint seals used in water and drainage applications — Thermoplastic elastomers*

ISO 22391-1:2009, *Plastics piping systems for hot and cold water installations — Polyethylene of raised temperature resistance (PE-RT) — Part 1: General*

ISO 22391-2:2009, *Plastics piping systems for hot and cold water installations — Polyethylene of raised temperature resistance (PE-RT) — Part 2: Pipes*

ISO 22391-5, *Plastics piping systems for hot and cold water installations — Polyethylene of raised temperature resistance (PE-RT) — Part 5: Fitness for purpose of the system*

EN 681-1, *Elastomeric seals — Materials requirements for pipe joint seals used in water and drainage applications — Part 1: Vulcanized rubber*

EN 681-2, *Elastomeric seals — Materials requirements for pipe joint seals used in water and drainage applications — Part 2: Thermoplastic elastomers*

EN 1254-3, *Copper and copper alloys — Plumbing fittings — Part 3: Fittings with compression ends for use with plastics pipes*

EN 10088-1, *Stainless steels — Part 1: List of stainless steels*

3 Terms, definitions, symbols and abbreviated terms

For the purposes of this document, the terms, definitions, symbols and abbreviated terms given in ISO 22391-1 and the following apply.

3.1 General fittings

3.1.1 fitting

component of a piping system, which connects two or more pipes and/or fittings together, without any additional function

3.2 Mechanical fittings

3.2.1

compression fitting

fitting in which the joint is made by the compression of a ring or sleeve on the outside wall of the pipe with or without additional sealing elements and with internal support

3.2.2

crimped fitting

fitting in which the joint is made by crimping of the fitting and/or a ring on the outside wall of the pipe by means of a special tool

3.2.3

flanged fitting

fitting in which the pipe connection consists of two mating flanges which are mechanically pressed together and sealed by the compression of an elastomeric sealing element between them

3.2.4

flat seat union fitting

fitting in which the pipe connection consists primarily of two components, at least one of which normally incorporates a flat sealing surface, which are mechanically pressed together by means of a screwed nut or similar and sealed by the compression of an elastomeric sealing element between them

3.3 Fittings for heat fusion

3.3.1

socket fusion fitting

fitting in which the joint with the pipe is made by melting together the outer part of the pipe with the inner part of the fitting by means of heat induced by a heated tool

3.3.2

electrofusion fitting

fitting in which the joint with the pipe is made by melting together the outer part of the pipe and the inner part of the fitting by means of heat induced by current flowing in an appropriate resistor inserted in the fitting body

3.3.3

fitting with incorporated inserts

fitting in which the joint is made by means of connecting threads or other outlets, inserted in the plastics body, combined with fusion ends for socket welding or electrofusion

4 Material characteristics

4.1 Plastics fitting material

4.1.1 Fitting material identical to PE-RT pipe material

The material from which fittings are made shall be in accordance with the requirements for pipes as specified in ISO 22391-2.

When tested using the test method and the test parameters in accordance with Table 1 or 2, injection moulded tubular test pieces shall withstand the hydrostatic (hoop) stress without bursting or leakage.

Table 1 — Mechanical characteristics of tubular test pieces made of PE-RT Type I by injection moulding

Characteristic	Requirement	Test parameters				Test methods
		For individual tests				
Resistance to internal pressure	No bursting or leakage during test period	Hydrostatic (hoop) stress	Test temperature	Test period	Number of test pieces	ISO 1167-1 and ISO 1167-2
		MPa	°C	h		
		9,9	20	1	3	
		3,4	95	1 000	3	
		For all tests				
Sampling procedure		Not specified				
Type of end cap		Type a)				
Orientation of test piece		Not specified				
Type of test		Water-in-water				

Table 2 — Mechanical characteristics of tubular test pieces made of PE-RT Type II by injection moulding

Characteristic	Requirement	Test parameters				Test methods
		For individual tests				
Resistance to internal pressure	No bursting or leakage during test period	Hydrostatic (hoop) stress	Test temperature	Test period	Number of test pieces	ISO 1167-1 and ISO 1167-2
		MPa	°C	h		
		10,8	20	1	3	
		3,6	95	1 000	3	
		For all tests				
Sampling procedure		Not specified				
Type of end cap		Type a)				
Orientation of test piece		Not specified				
Type of test		Water-in-water				

4.1.2 PE-RT fitting material not identical to PE-RT pipe material

4.1.2.1 Evaluation of σ_{LCL} values and control points

The fitting material, in the form of injection-moulded tubular test pieces, shall be evaluated in accordance with ISO 9080 or equivalent, with internal pressure tests being carried out in accordance with ISO 1167-1 and ISO 1167-2 in order to determine the σ_{LCL} values. The σ_{LCL} values thus determined shall be used to determine the design stress, σ_{DF} (see ISO 22391-2:2009, Annex A) and values of hydrostatic stress, σ_F , corresponding to the temperature and time control points given in Table 3.

NOTE One equivalent way of evaluation is to calculate the σ_{LCL} value for each temperature (for example 20 °C, 60 °C and 95 °C), individually.

If evaluation according to ISO 9080 or equivalent is available from long-term internal pressure tests relative to extruded pipes of the same compound as is used for the fitting, the injection-moulded tubular test pieces shall conform to the times for failure at the hydrostatic stress levels for the materials corresponding to the test temperature and the control points given in Table 3.

The relevant test temperature shall be higher than or equal to the maximum design temperature, T_{\max} , for the service condition class.

Table 3 — Control points for testing fitting materials with tubular test pieces relative to classification of service conditions

	Application class				
	All	1	2	4	5
Maximum design temperature, T_{\max} , °C	—	80	80	70	90
Test temperature, T_{test} , °C	20	95 ^a	95 ^a	80	95
Test duration, t , h	1	1 000	1 000	1 000	1 000
^a Test is conducted at 95 °C to match existing test facilities.					

It is recommended that the nominal diameter of the injection-moulded tubular test pieces be in the range of the nominal diameters of fittings normally produced by the manufacturer.

4.1.2.2 Thermal stability

The thermal stability shall be tested by means of hydrostatic pressure testing in accordance with ISO 1167-1 and ISO 1167-2 at 110 °C for 8 760 h, using a test piece in pipe form or a fitting connected to pipes. The test piece shall withstand the test without bursting. The test shall be conducted in water-in-air at an internal pressure equivalent to the hydrostatic stress used in the pipe material thermal stability test.

If a fitting connected to pipes is used as a test piece and the pipe connection fails, then the thermal stability test shall be repeated using a test piece in pipe form.

4.1.3 Plastics fitting material other than PE-RT

Plastics material other than PE-RT for fittings intended to be used in PE-RT piping systems for hot and cold water installations within buildings for the conveyance of water, whether or not the water is intended for human consumption (domestic systems) or heating systems, shall conform to 4.1.2.

4.2 Metallic fitting material

Metallic material for fittings intended to be used with components conforming to ISO 22391 shall be in accordance with EN 1254-3 or EN 10088-1, as applicable.

4.3 Influence on water intended for human consumption

The material shall be in accordance with ISO 22391-1.

5 General characteristics

5.1 Appearance

When viewed without magnification, the internal and external surfaces of fittings shall be smooth, clean and free from an extent of scoring, cavities and other surface defects, which would prevent conformance with this

part of ISO 22391. The material shall not contain visible impurities. Slight variations in the appearance of the colour are permitted. Each end of a fitting shall be square to its axis.

5.2 Opacity

Fittings that are declared to be opaque shall not transmit more than 0,2 % of visible light when tested in accordance with ISO 7686.

NOTE This test is not necessary when the fitting body material is of the same opaque PE-RT compound as the pipe.

6 Geometrical characteristics

6.1 General

Dimensions shall be measured in accordance with ISO 3126.

6.1.1 Nominal diameter(s)

The nominal diameter(s), d_n , of a fitting shall correspond to, and be designated by, the nominal outside diameter(s) of the pipe(s) conforming to ISO 22391-2 for which they are designed.

6.1.2 Angles

The preferred nominal angles of non-straight fittings are 45° and 90°.

6.1.3 Threads

Threads used for jointing shall be in accordance with ISO 7-1. Where a thread is used as a fastening thread for jointing an assembly (e.g. union nuts), it shall be in accordance with ISO 228-1, except that these requirements need not apply to the threads used by the manufacturer to join component parts of a fitting together.

6.2 Dimensions of sockets for socket fusion and electrofusion fittings

6.2.1 Dimensions of socket fusion fittings

The principal dimensions for socket weld fittings (see Figure 1), shall be in accordance with Table 4 or 5, as applicable.

Table 4 — Socket dimensions relative to length of socket fusion fittings

Dimensions in millimetres

Nominal diameter of the fitting d_n	Socket reference length L	Actual length of socket L_1	Heated socket length L_2		Penetration of pipe into socket L_3		Heated length of pipe L_4
	L_{min}	$L_{1, min}$	$L_{2, min}$	$L_{2, max}$	$L_{3, min}$	$L_{3, max}$	$L_{4, min}$
	16	13,3	13,3	10,8	13,3	9,8	13,3
20	14,5	14,5	12,0	14,5	11,0	14,5	11,0
25	16,0	16,0	13,5	16,0	12,5	16,0	12,5
32	18,1	18,1	15,6	18,1	14,6	18,1	14,6
40	20,5	20,5	18,0	20,5	17,0	20,5	17,0
50	23,5	23,5	21,0	23,5	20,0	23,5	20,0
63	27,4	27,4	24,9	27,4	23,9	27,4	23,9
75	31,0	31,0	28,5	31,0	27,5	31,0	27,5
90	35,5	35,5	33,0	35,5	32,0	35,5	32,0
110	41,5	41,5	39,0	41,5	38,0	41,5	38,0

$L_{min} = 0,3d_n + 8,5$; $L_{1, min} = L_{min}$; $L_{2, min} = L_{min} - 2,5$; $L_{2, max} = L_{min}$; $L_{3, min} = L_{min} - 3,5$; $L_{3, max} = L_{min}$; $L_{4, min} = L_{min} - 3,5$.

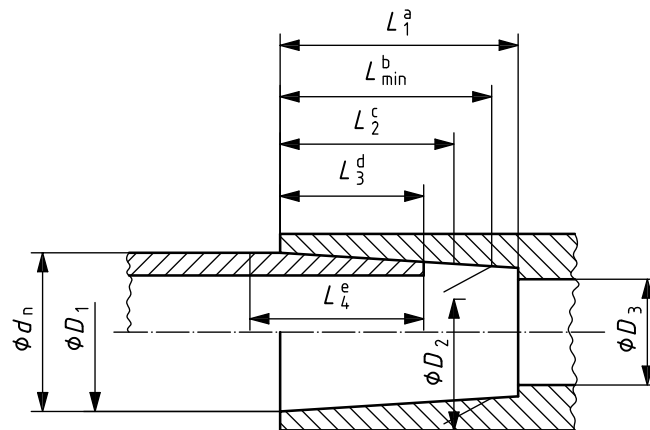

Key

- D_1 mean inside mouth diameter of socket, which comprises the mean diameter of the circle at the inner section of the extension of the socket with the plane of the socket mouth
- D_2 mean inside root diameter of socket (mean diameter of circle in plane parallel to plane of mouth and separated from it by distance L_{min})
- D_3 minimum bore (minimum diameter of flow channel through body of fitting)
- d_n nominal outside diameter
- L_{min} reference socket length (theoretical minimum socket length used for calculation purposes)
- L_1 actual length of socket (distance from mouth to shoulder, if any)
- L_2 heated length of fitting (length of penetration of heated tool into socket)
- L_3 insertion length (depth of penetration of heated pipe end or spigot end of fitting into socket)
- L_4 heated length of pipe (depth of penetration of pipe end or spigot end of fitting into heated tool)
- a The minimum value of L_1 shall be L_{min} .
- b The minimum value of L_{min} shall be $(0,3d_n + 8,5)$ mm.
- c The minimum value of L_2 is $(L_{min} - 2,5)$ mm. The maximum value of L_2 shall be L_{min} .
- d The minimum value of L_3 is $(L_{min} - 3,5)$ mm. The maximum value of L_3 shall be L_{min} .
- e The minimum value of L_4 shall be $(L_{min} - 3,5)$ mm.

Figure 1 — Socket and spigot dimensions for socket fusion fittings

Table 5 — Socket dimensions of socket fusion fittings relative to diameter

Dimensions in millimetres

Nominal diameter of fitting d_n	Mean inside diameter of socket				Maximum out-of-roundness ^a	Minimum bore ^b D_3
	Root D_1		Root D_2			
	$D_{1, \min}$	$D_{1, \max}$	$D_{2, \min}$	$D_{2, \max}$		$D_{3, \min}$
Peeling techniques optional						
16	15,0	15,5	14,8	15,3	0,6	9
20	19,0	19,5	18,8	19,3	0,6	13
25	23,8	24,4	23,5	24,1	0,7	18
32	30,7	31,3	30,4	31,0	0,7	25
40	38,7	39,3	38,3	38,9	0,7	31
50	48,7	49,3	48,3	48,9	0,8	39
63	61,6	62,2	61,1	61,7	0,8	49
Peeling techniques not used						
75	73,2	74,0	71,9	72,7	1,0	58,2
90	87,8	88,8	86,4	87,4	1,2	69,8
110	107,5	108,5	105,8	106,8	1,4	85,4
Peeling techniques always used						
75	72,6	73,2	72,3	72,9	1,0	58,2
90	87,1	87,8	86,7	87,4	1,2	69,8
110	106,3	107,1	105,7	106,5	1,4	85,4

^a The out-of-roundness is the maximum inside diameter minus the minimum inside diameter of the socket measured in the same plane parallel to the plane of the socket mouth.

^b Only applicable if a shoulder exists.

6.2.2 Dimensions of sockets for electrofusion fittings

The principal dimensions of sockets for electrofusion fittings (see Figure 2) shall be in accordance with Table 6.

The values of lengths, L_1 and L_2 , as given in Figure 2, shall be in accordance with Table 6. The manufacturer shall declare the actual length.

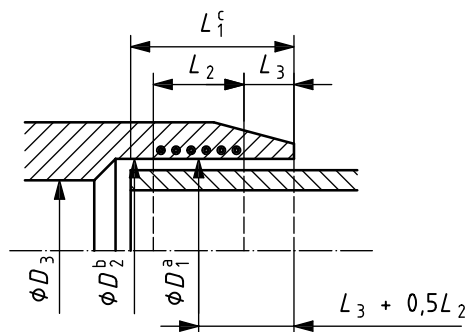

Key

D_1 mean inside diameter of the fusion zone

D_2 minimum inside diameter of socket

D_3 minimum bore (minimum diameter of flow channel through the body of the fitting)

L_1 depth of penetration of pipe or male end of spigot fitting

L_2 nominal length of fusion zone (heated length, as declared by the manufacturer)

L_3 nominal unheated entrance length of fitting (distance between the mouth of the fitting and the start of the fusion zone, as declared by the manufacturer)

^a The mean inside diameter when measured in any plane parallel to the plane of the mouth at a distance $L_3 + 0,5L_2$ from that face.

^b Measured in any plane parallel to the plane of the mouth at a distance not greater than L_1 from that plane.

^c In the case of a coupling without a stop, L_1 is no greater than half the total length of the fitting.

Figure 2 — Principal dimensions of electrofusion fittings

Table 6 — Socket dimensions for electrofusion fittings

Dimensions in millimetres

Nominal diameter of the fitting d_n	Minimum mean inside diameter ^a of fusion zone $D_{1, \text{min}}$	Nominal length of fusion zone $L_{2, \text{min}}$	Depth of penetration	
			$L_{1, \text{min}}$	$L_{1, \text{max}}$
16	16,1	10	20	35
20	20,1	10	20	37
25	25,1	10	20	40
32	32,1	10	20	44
40	40,1	10	20	49
50	50,1	10	20	55
63	63,2	11	23	63
75	75,2	12	25	70
90	90,2	13	28	79
110	110,3	15	32	85
125	125,3	16	35	90
140	140,3	18	38	95
160	160,4	20	42	101

^a In piping systems that involve spigot trimming, smaller values for D_1 are permitted if conforming to the manufacturer's specification.

6.3 Dimensions of metallic fittings

Metallic fittings shall be in accordance with EN 1254-3.

7 Mechanical characteristics of plastics fittings

7.1 General

When tested in accordance with ISO 1167-1 and ISO 1167-2 using the test parameters given in Table 7 or Table 8, where the test pressure is given in relation to the class of fitting and design pressure, the component shall withstand the test pressure, p_F , without bursting or leakage during the test period.

The testing shall be conducted with water-internal, air-external.

The test pressure shall be calculated using Equation (1):

$$p_F = p_D \times \frac{\sigma_F}{\sigma_{DF}} \quad (1)$$

where

- p_F is the hydrostatic test pressure, in bar²⁾, to be applied to the fitting body during the test period;
- σ_F is the value of the hydrostatic stress, in megapascal (MPa), of the fitting body material corresponding to the test duration and test temperature conditions according to Table 7 or Table 8;
- σ_{DF} is the design stress value, in megapascals (MPa), of the fitting body material, as determined for the appropriate service condition class from data produced in accordance with 4.1 and ISO 22391-2:2009, Annex A;
- p_D is the design pressure of 4 bar, 6 bar, 8 bar or 10 bar, as applicable.

Fittings may be connected to the pipes for which they are intended to be used. Other methods may be used to seal the ends of the fitting body in order that the required pressure can be applied.

7.2 Fitting material identical to PE-RT compound

In this case, σ_{DF} will have the same value as σ_{DP} : the fitting shall be in accordance with Table 7 or Table 8 using the test pressure, p_F , given therein, as applicable to the class of fitting and the design pressure.

7.3 Fitting made from PE-RT but not identical to PE-RT compound

The fitting shall be in accordance with Table 7 or Table 8 in respect of test temperature and minimum time to failure, as applicable to the class of fitting and design pressure, and using Equation (1) and relevant values for hydrostatic stress, σ_F , and design stress, σ_{DF} (derived in accordance with 4.1.2), in order to determine the test pressure, p_F .

7.4 Fittings made from plastics other than PE-RT

Fittings intended to be used in PE-RT piping systems for hot and cold water installations within buildings for the conveyance of water, whether or not the water is intended for human consumption (domestic systems) or heating systems, shall be in accordance with 7.3.

2) 1 bar = 0,1 MPa = 10⁵ Pa; 1 MPa = 1 N/mm².

Table 7 — Determination of test pressure, p_F , for PE-RT Type I

	Application class							
	1		2		4		5	
Maximum design temperature, T_{max} , °C	80		80		70		90	
Design stress of fitting material, σ_{DF} , MPa	3,29		2,68		3,25		2,38	
Test temperature ^a , T_{test} , °C	20	95	20	95	20	80	20	95
Test duration, t , h	1	1 000	1	1 000	1	1 000	1	1 000
Hydrostatic stress of fitting material, σ_P , MPa	9,9	3,4	9,9	3,4	9,9	4,5	9,9	3,4
Test pressure, p_F , bar for a design pressure, p_D , of								
4 bar	14,8 ^b	5,1 ^b	14,8 ^b	5,1 ^b	14,8 ^b	6,8 ^b	16,6	5,8
6 bar	18,0	6,3	22,1	7,7	18,2	8,4	24,8	8,7
8 bar	24,0	8,3	29,4	10,2	24,3	11,2	33,1	11,5
10 bar	29,9	10,4	36,8	12,8	30,3	14,0	41,4	14,4
Number of test pieces	3	3	3	3	3	3	3	3
<p>^a Generally the highest test temperature is taken to be $(T_{max} + 10)$ °C with an upper limit of 95 °C. However, in order to match existing test facilities, the highest test temperature for classes 1 and 2 is also set at 95 °C. The hydrostatic stresses given correspond to the given test.</p> <p>^b The 20 °C, 10 bar, 50 years, cold water requirement, being higher, determines this value (see ISO 22391-1:2009, Clause 4).</p>								

Table 8 — Determination of test pressure, p_F , for PE-RT Type II

	Application class							
	1		2		4		5	
Maximum design temperature, T_{max} , °C	80		80		70		90	
Design stress of fitting material, σ_{DF} , MPa	3,53		3,37		3,38		2,88	
Test temperature ^a , T_{test} , °C	20	95	20	95	20	80	20	95
Test duration, t , h	1	1 000	1	1 000	1	1 000	1	1 000
Hydrostatic stress of fitting material, σ_P , MPa	10,8	3,6	10,8	3,6	10,8	4,81	10,8	3,6
Test pressure, p_F , bar for a design pressure, p_D , of								
4 bar	14,5 ^b	4,8 ^b	14,5 ^b	4,8 ^b	14,5 ^b	6,4 ^b	15,0	5,0
6 bar	18,4	6,1	19,3	6,4	19,2	8,5	22,6	7,5
8 bar	24,5	8,1	25,7	8,5	25,6	11,4	30,1	10,0
10 bar	30,7	10,2	32,1	10,6	32,0	14,2	37,6	12,4
Number of test pieces	3	3	3	3	3	3	3	3
<p>^a Generally the highest test temperature is taken to be $(T_{max} + 10)$ °C with an upper limit of 95 °C. However, in order to match existing test facilities, the highest test temperature for classes 1 and 2 is also set at 95 °C. The hydrostatic stresses given correspond to the given test.</p> <p>^b The 20 °C, 10 bar, 50 years, cold water requirement, being higher, determines this value (see ISO 22391-1:2009, Clause 4).</p>								

8 Physical and chemical characteristics of plastics components

8.1 Melt mass flow rate

The melt mass flow rate (MFR) of the compound and the injection-moulded fitting made therefrom shall be determined in accordance with ISO 1133-1, using the temperature and force criteria appropriate to the material. The difference between the MFR of the injection-moulded material taken from the fitting and the MFR of the original compound shall be determined.

For PE-RT compounds and injection-moulded products of the same compound, conditions T (190/5) in accordance with ISO 1133-1 shall be used: the difference between the MFR values shall not be greater than 30 %.

For other thermoplastics, appropriate procedures and the maximum difference between MFR values shall be used.

9 Sealing elements

The sealing element shall have no detrimental effect on the properties of the pipe or fitting and shall not cause the test assembly to fail to conform to ISO 22391-5.

The material of the elastomeric sealing elements used in joint assemblies shall be in accordance with ISO 23711, EN 681-1 or EN 681-2, as applicable.

10 System performance requirements

When fittings conforming to this part of ISO 22391 are jointed to pipes conforming to ISO 22391-2, the joints shall be in accordance with ISO 22391-5.

11 Marking

11.1 General requirements

11.1.1 Marking details shall be printed or formed directly on the fitting such that, after storage, handling and installation, legibility is maintained.

NOTE The manufacturer is not responsible for marking being illegible on the components owing to actions such as painting, scratching, covering of the components or by use of detergent, unless this is agreed on or specified by the manufacturer.

11.1.2 Marking shall not initiate cracks or other types of defects which adversely influence the performance of the fitting.

11.1.3 If printing is used, the colour of the printed information shall differ from the basic colouring of the fitting.

11.1.4 The size of the marking shall be such that the marking is legible without magnification.

11.2 Minimum required marking

The minimum required marking of fittings conforming to ISO 22391 shall be in accordance with Table 9.

Table 9 — Minimum required marking

Aspect	Marking or symbol
Identification of conformity	ISO 22391
Manufacturer's name and/or trade mark	Name or code
Nominal diameter, d_n^a	e.g. 16
Nominal wall thickness(es) of the corresponding pipe(s) (for compression or crimped fittings only)	e.g. 2,2
Material identification (for fusion fittings only) ^a	PE-RT Type I or Type II
Application class combined with design pressure	e.g. Class 1/10 bar
Opacity ^b	e.g. opaque
Manufacturer's information ^a	c
<p>^a Where appropriate, this shall be marked on the fitting. All other aspects may be marked on the fitting or, alternatively, placed on a label supplied with the fitting.</p> <p>^b If declared by the manufacturer.</p> <p>^c To provide traceability, the following details shall be given:</p> <ul style="list-style-type: none"> — the production period, year and month, in figures or in code; — a name or code for the production site, if the manufacturer is producing at different sites. 	

Bibliography

- [1] ENV 12108, *Plastics piping systems — Guidance for the installation inside buildings of pressure piping systems for hot and cold water intended for human consumption*

© ISO 2009. All rights reserved.

ICS 23.040.45; 91.140.60; 93.025

Price based on 14 pages