**Fine ceramics (advanced ceramics,
advanced technical ceramics) — Test
method for air-purification performance
of semiconducting photocatalytic
materials —**

**Part 3:
Removal of toluene**

*Céramiques techniques — Méthodes d'essai relatives à la performance
des matériaux photocatalytiques semi-conducteurs pour la purification
de l'air —*

Partie 3: Élimination du toluène



Reference number
ISO 22197-3:2011(E)

© ISO 2011

PDF disclaimer

This PDF file may contain embedded typefaces. In accordance with Adobe's licensing policy, this file may be printed or viewed but shall not be edited unless the typefaces which are embedded are licensed to and installed on the computer performing the editing. In downloading this file, parties accept therein the responsibility of not infringing Adobe's licensing policy. The ISO Central Secretariat accepts no liability in this area.

Adobe is a trademark of Adobe Systems Incorporated.

Details of the software products used to create this PDF file can be found in the General Info relative to the file; the PDF-creation parameters were optimized for printing. Every care has been taken to ensure that the file is suitable for use by ISO member bodies. In the unlikely event that a problem relating to it is found, please inform the Central Secretariat at the address given below.



COPYRIGHT PROTECTED DOCUMENT

© ISO 2011

All rights reserved. Unless otherwise specified, no part of this publication may be reproduced or utilized in any form or by any means, electronic or mechanical, including photocopying and microfilm, without permission in writing from either ISO at the address below or ISO's member body in the country of the requester.

ISO copyright office
Case postale 56 • CH-1211 Geneva 20
Tel. + 41 22 749 01 11
Fax + 41 22 749 09 47
E-mail copyright@iso.org
Web www.iso.org

Published in Switzerland

Contents

Page

Foreword	iv
1 Scope	1
2 Normative references	1
3 Terms and definitions	2
4 Symbols	3
5 Principle	3
6 Apparatus	3
6.1 Test equipment	3
6.2 Test gas supply	4
6.3 Photoreactor	5
6.4 Light source	6
6.5 Analytical system	6
7 Test piece	7
8 Procedure	7
8.1 General aspects	7
8.2 Pretreatment of test piece	7
8.3 Toluene removal test	8
9 Calculation	8
10 Test method for test pieces with lower performance	9
11 Test report	9
Annex A (informative) Results of round-robin test	10
Bibliography	11

Foreword

ISO (the International Organization for Standardization) is a worldwide federation of national standards bodies (ISO member bodies). The work of preparing International Standards is normally carried out through ISO technical committees. Each member body interested in a subject for which a technical committee has been established has the right to be represented on that committee. International organizations, governmental and non-governmental, in liaison with ISO, also take part in the work. ISO collaborates closely with the International Electrotechnical Commission (IEC) on all matters of electrotechnical standardization.

International Standards are drafted in accordance with the rules given in the ISO/IEC Directives, Part 2.

The main task of technical committees is to prepare International Standards. Draft International Standards adopted by the technical committees are circulated to the member bodies for voting. Publication as an International Standard requires approval by at least 75 % of the member bodies casting a vote.

Attention is drawn to the possibility that some of the elements of this document may be the subject of patent rights. ISO shall not be held responsible for identifying any or all such patent rights.

ISO 22197-3 was prepared by Technical Committee ISO/TC 206, *Fine ceramics*.

ISO 22197 consists of the following parts, under the general title *Fine ceramics (advanced ceramics, advanced technical ceramics) — Test method for air-purification performance of semiconducting photocatalytic materials*:

- *Part 1: Removal of nitric oxide*
- *Part 2: Removal of acetaldehyde*
- *Part 3: Removal of toluene*
- *Part 4: Removal of formaldehyde*
- *Part 5: Removal of methyl mercaptan*

Fine ceramics (advanced ceramics, advanced technical ceramics) — Test method for air-purification performance of semiconducting photocatalytic materials —

Part 3: Removal of toluene

1 Scope

This part of ISO 22197 specifies a test method for the determination of the air-purification performance of materials that contain a photocatalyst or have photocatalytic films on the surface, usually made from semiconducting metal oxides, such as titanium dioxide or other ceramic materials, by continuous exposure of a test piece to the model air pollutant under illumination with ultraviolet light (UV-A). This part of ISO 22197 is intended for use with different kinds of materials, such as construction materials in flat sheet, board or plate shape, that are the basic forms of materials for various applications. This part of ISO 22197 also applies to structured filter materials including honeycomb-form, woven and non-woven fabrics, and to plastic or paper materials if they contain ceramic microcrystals and composites. This part of ISO 22197 does not apply to powder or granular photocatalytic materials.

This test method is usually applicable to photocatalytic materials produced for air purification. This method is not suitable for the determination of other performance attributes of photocatalytic materials, i.e. decomposition of water contaminants, self-cleaning, antifogging and antibacterial actions. It concerns the removal of toluene.

2 Normative references

The following referenced documents are indispensable for the application of this document. For dated references, only the edition cited applies. For undated references, the latest edition of the referenced document (including any amendments) applies.

ISO 80000-1:2009, *Quantities and units — Part 1: General*

ISO 2718:1974, *Standard layout for a method of chemical analysis by gas chromatography*

ISO 4677-1:1985, *Atmospheres for conditioning and testing — Determination of relative humidity — Part 1: Aspirated psychrometer method*

ISO 4892-3:2006, *Plastics — Methods of exposure to laboratory light sources — Part 3: Fluorescent UV lamps*

ISO 5725-2:1994, *Accuracy (trueness and precision) of measurement methods and results — Part 2: Basic method for the determination of repeatability and reproducibility of a standard measurement method*

ISO 6145-7:2001, *Gas analysis — Preparation of calibration gas mixtures using dynamic volumetric methods — Part 7: Thermal mass-flow controllers*

ISO 10677:—¹⁾, *Fine ceramics (advanced ceramics, advanced technical ceramics) — Ultraviolet light source for testing semiconducting photocatalytic materials*

ISO/IEC 17025:2005, *General requirements for the competence of testing and calibration laboratories*

ISO 22197-1:2007, *Fine ceramics (advanced ceramics, advanced technical ceramics) — Test method for air-purification performance of semiconducting photocatalytic materials — Part 1: Removal of nitric oxide*

3 Terms and definitions

For the purposes of this document, the following terms and definitions apply.

3.1 photocatalyst

substance that performs one or more functions based on oxidization and reduction reactions under photoirradiation, including decomposition and removal of air and water contaminants, deodorization, and antibacterial, self-cleaning and antifogging actions

3.2 photocatalytic materials

materials in which or on which the photocatalyst is added by coating, impregnation, mixing, etc.

NOTE Such photocatalytic materials are intended primarily for use as building and road construction materials to obtain the above-mentioned functions.

3.3 zero-calibration gas

air that does not contain pollutants (i.e. in which common pollutants are below 0,01 µl/l)

NOTE The zero-calibration gas is prepared from indoor air using a laboratory air-purification system, or supplied as synthetic air in a gas cylinder.

3.4 standard gas

diluted gases of known concentrations supplied in cylinders and certified by an accredited laboratory

3.5 test gas

mixture of air and pollutant(s) of known concentration prepared from a standard gas or a zero-calibration gas, to be used for the performance test of a photocatalytic material

NOTE The flow rate, concentration, etc., are expressed at the standard state (0 °C, 101,3 kPa) and dry-gas basis (exclusion of water vapour).

3.6 dark condition

test condition with no light illumination by the light source for testing and room lighting

NOTE Usually the test gas is supplied for comparison with the illuminated reaction.

1) To be published.

4 Symbols

For the purposes of this document, the following symbols apply.

f	the flow rate of test gas converted into that at the standard state (0 °C, 101,3 kPa, and dry-gas basis) (l/min)
ϕ_T	the volume fraction of toluene at the reactor exit ($\mu\text{l/l}$)
ϕ_{T0}	the supply volume fraction of toluene ($\mu\text{l/l}$)
n_T	the quantity of toluene removed by the test piece (μmol)
R	the removal percentage, by test piece, of toluene (%)

5 Principle

This part of ISO 22197 concerns the development, comparison, quality assurance, characterization, reliability, and design data generation of photocatalytic materials (Reference [3] in the Bibliography). The method described is intended to obtain the air-purification performance of photocatalytic materials by exposing a test piece to model polluted air under illumination by ultraviolet (UV) light (Reference [4] in the Bibliography). Toluene (C_7H_8) is chosen as a typical aromatic volatile organic compound (VOC) with offensive odour. The test piece, placed in a flow-type photoreactor, is activated by UV illumination, and adsorbs and oxidizes gas-phase toluene to form carbon dioxide (CO_2) and other oxidation products (References [5] to [7] in the Bibliography). The air-purification performance is determined from the amount of toluene removed by the test piece, in micromoles (μmol). The simple adsorption by the test piece (not due to photocatalysis) is evaluated by tests in the dark. However, some test pieces adsorb toluene very strongly, and a stable concentration of toluene may not be attained in the designated time of test. The photocatalytic activity may depend on physical and chemical properties of pollutants, mainly due to the adsorption process involved. For a better evaluation of air-purification performance of photocatalytic materials, it is recommended to combine one or more suitable test methods as described in other parts of ISO 22197.

6 Apparatus

6.1 Test equipment

The test equipment enables a photocatalytic material to be examined for its pollutant-removal capability by supplying the test gas continuously, while providing photoirradiation to activate the photocatalyst. It is the same as that used in the test method for the removal of nitric oxide (ISO 22197-1) and consists of a test gas supply, a photoreactor, a light source, and pollutant-measurement equipment. Since low concentrations of pollutants are to be tested, the system shall be constructed with materials of low adsorption and resistant to ultraviolet (UV) radiation (e.g. acrylic resin, borosilicate glass). An example of a testing system is shown in Figure 1.

Dimensions in millimetres

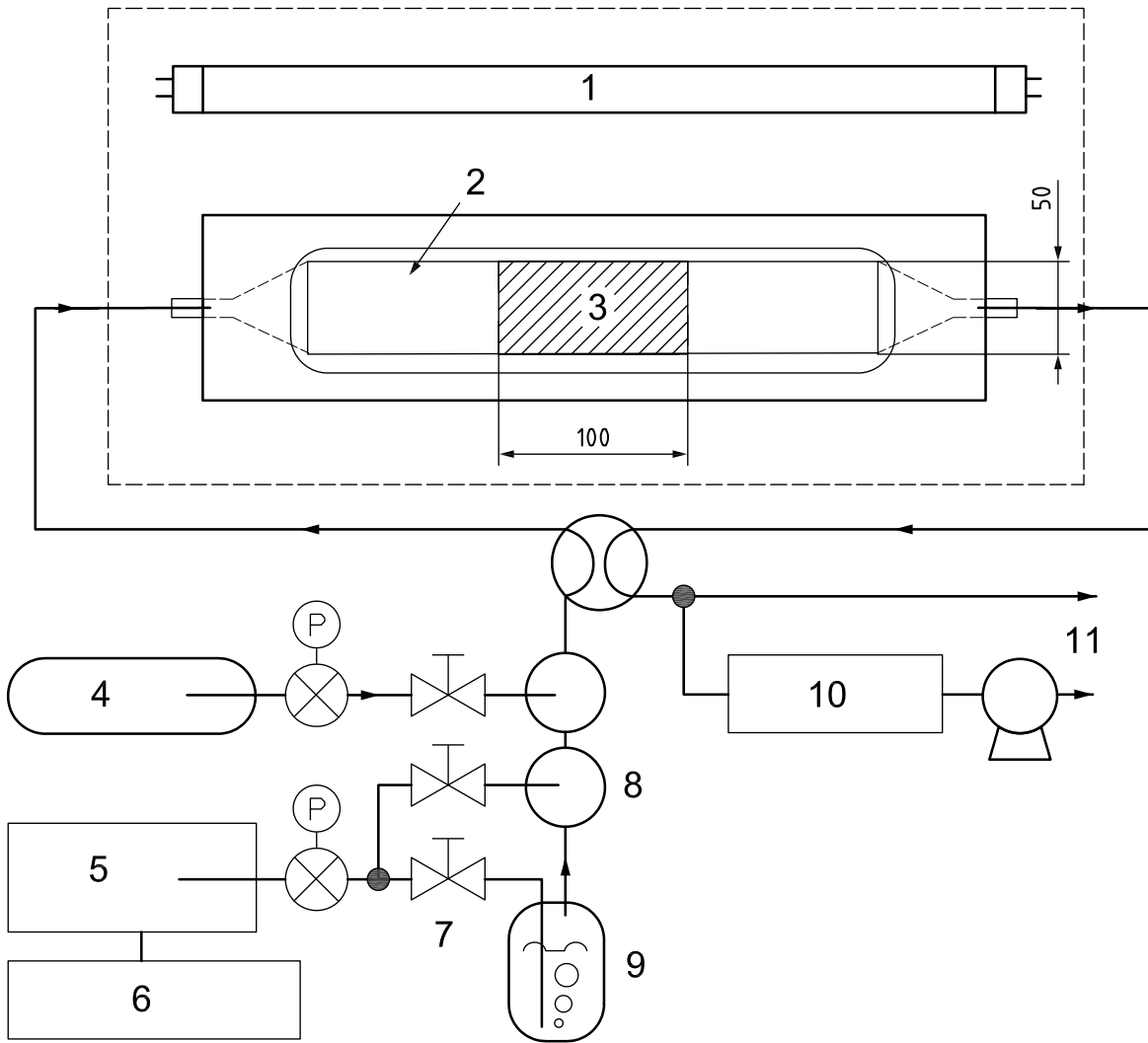

Key

- | | |
|----------------------------|------------------------|
| 1 light source | 7 mass-flow controller |
| 2 optical window | 8 gas mixers |
| 3 test piece | 9 humidifier |
| 4 standard gas (pollutant) | 10 analyser |
| 5 air-purification system | 11 vent |
| 6 compressor | |

Figure 1 — Schematic diagram of test equipment

6.2 Test gas supply

The test gas supply provides air polluted with the model contaminant at a predetermined concentration, temperature and humidity, and supplies it continuously to the photoreactor. It consists of flow regulators, a humidifier, gas mixers, etc. The flow rate of each gas should be within 5 % of the designated value, which is easily attained by using thermal mass-flow controllers, with knowledge of the temperature and gas type at calibration in accordance with ISO 6145-7. The expression of gas flow rate in this part of ISO 22197 is that converted to the standard state (0 °C, 101,3 kPa, and dry-gas basis). Typical capacities of flow controller for pollutant gas, dry air and wet air are 10 ml/min, 500 ml/min and 500 ml/min, respectively. The standard toluene gas before dilution, normally balanced with nitrogen in a cylinder, shall have a volume fraction of 10 µl/l to 50 µl/l.

6.3 Photoreactor

The photoreactor holds a planar test piece within a 50 mm wide trough, with its surface parallel to an optical window for photoirradiation. The reactor shall be fabricated from materials that adsorb little test gas and withstand irradiation of near-UV light. The test piece shall be separated from the window by a $5,0 \text{ mm} \pm 0,5 \text{ mm}$ thick air layer. The test gas shall pass only through the space between the test piece and the window. This gap shall be accurately set up according to the thickness of the test piece, for example, by using height-adjusting plates with different thicknesses, as shown in Figure 2 a). When a filter-type material is tested, an alternative type of test-piece holder shall be used, which holds the test piece while allowing the test gas to pass through the cells of the filter under illumination [Figure 2 b)]. Quartz or borosilicate glass that absorbs minimal light at wavelengths longer than 300 nm shall be used for the window.

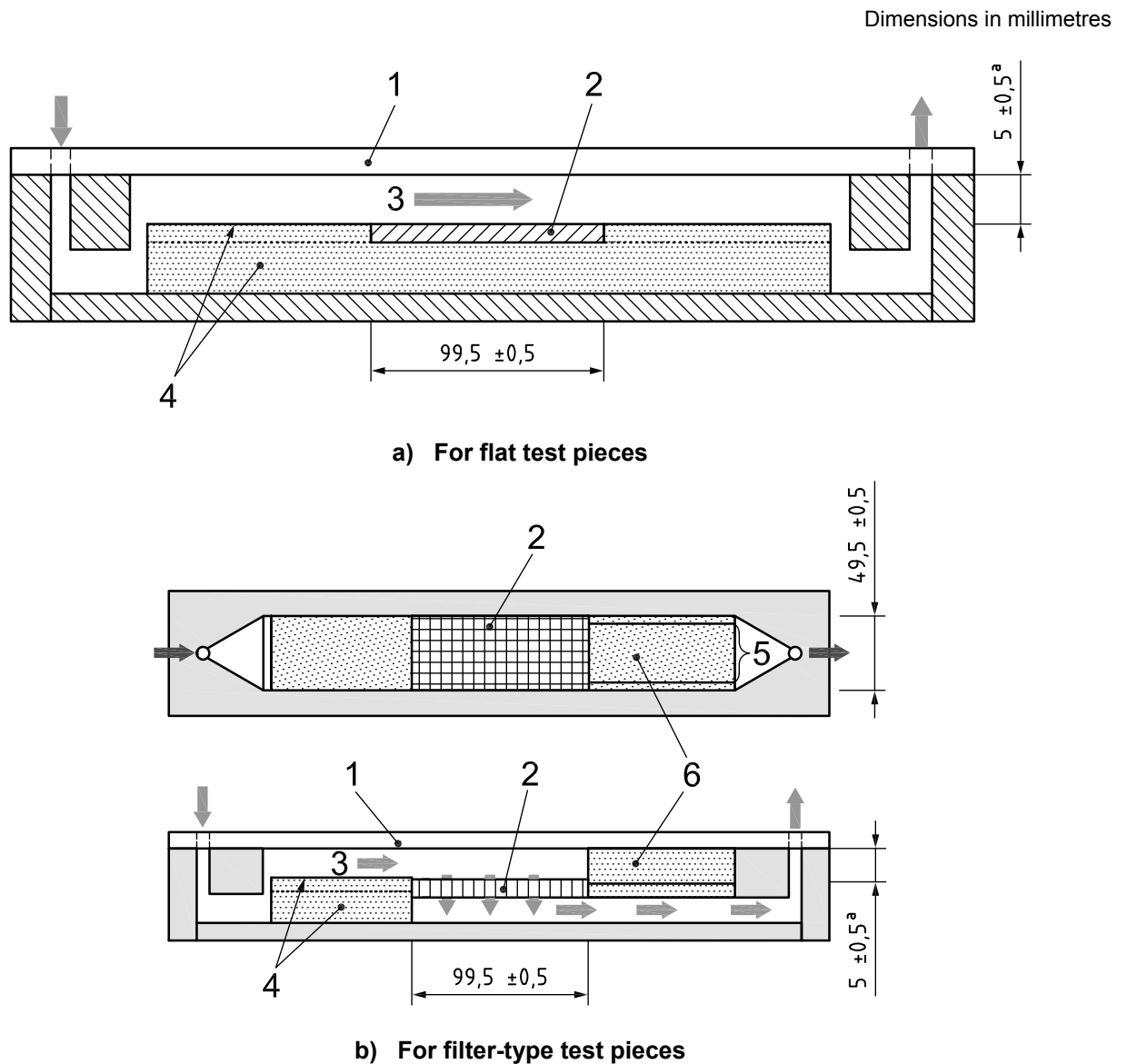

Key

- | | |
|--------------|--------------------------|
| 1 window | 4 height-adjusting plate |
| 2 test piece | 5 flow channel |
| 3 test gas | 6 test-piece holder |

^a Air-layer thickness.

Figure 2 — Cross-sectional views of photoreactor (axial)

6.4 Light source

The light source shall provide UV-A illumination within a wavelength range of 300 nm to 400 nm. Suitable sources include the so-called black light (BL) and black light blue (BLB) fluorescent lamps, with a maximum at 351 nm or 368 nm, as specified in ISO 4892-3, and xenon arc lamps with optical filters that block radiation below 300 nm. In the case of a xenon arc lamp, a cooling system shall be used in accordance with ISO 10677. The test piece shall be irradiated uniformly through the window by the light source. In the case of testing filter-type photocatalysts, the light source shall illuminate one end of the test piece. A light source that requires warming up shall be equipped with a shutter. The distance between the light source and the reactor shall be adjusted so that the UV irradiance (300 nm to 400 nm) at the sample surface is $10 \text{ W/m}^2 \pm 0,5 \text{ W/m}^2$. This distance shall be determined independently without using the photoreactor. A UV radiometer in conformity with ISO 10677 shall be put behind the optical window or its equivalent, at the same level as the test piece to be tested. The irradiance along the length of the test piece shall also be constant within $\pm 5 \%$. The reactor shall be shielded from external light if necessary.

6.5 Analytical system

The concentration of toluene shall be determined by gas chromatography. Either a packed column or capillary column, as described in ISO 2718, can be used, as long as it can separate toluene from related organic compounds. The detection shall be made by either flame ionization detector (FID) or photoionization detector (PID). The test gas is sampled with a gastight syringe. However, use of a six-way valve is recommended for reproducible and automatic sampling. The flow diagram when a six-way valve is used is shown in Figure 3. A small sampling pump continuously ventilates the metering tube with the test gas. The pump is stopped when the test gas is sampled by switching the six-way valve. The volume of the metering tube is typically 0,5 ml, but it shall be determined by the sensitivity of the analytical system.

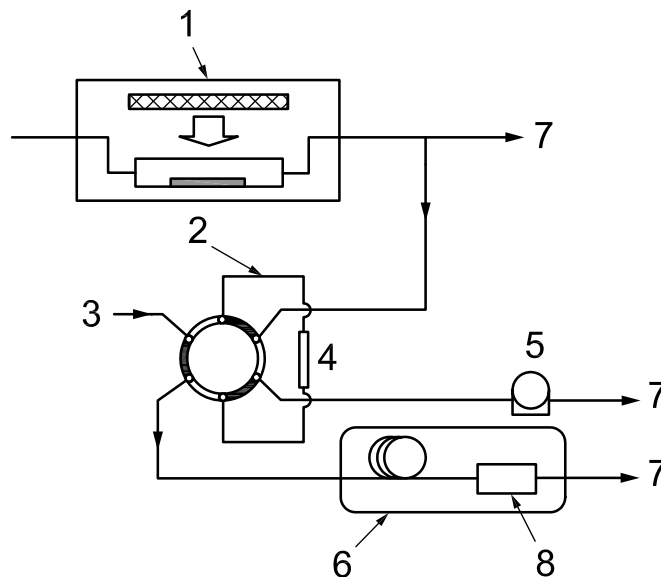

Key

- 1 photoreactor
- 2 six-way valve
- 3 carrier gas
- 4 metering tube
- 5 sampling pump
- 6 gas chromatograph
- 7 vent
- 8 FID

Figure 3 — Gas sampling system

7 Test piece

The test piece shall be a flat material or a filter-type material $49,5 \text{ mm} \pm 0,5 \text{ mm}$ wide and $99,5 \text{ mm} \pm 0,5 \text{ mm}$ long. It may be cut to these dimensions from a larger bulk material or coated sheet, or may be specially prepared for the test by coating a precut substrate. The thickness of the test piece shall ideally be less than 5 mm, in order to minimize the contribution from the side faces. If thicker test pieces are to be tested, the side faces shall be sealed with an inert material before testing. The filter-type test piece shall not be thicker than 20 mm.

8 Procedure

8.1 General aspects

The test procedure consists of pretreatment of the test piece, an adsorption process in the dark, and measurements of removal quantity and percentage of toluene under photoirradiation. An example of the concentration change of toluene during the test is shown in Figure 4. This part of ISO 22197 cannot be applied to certain test pieces that contain a large amount of adsorbent, due to unattained adsorption equilibrium. Some test pieces may not give accurate removal of toluene due to lower photocatalytic activity. In this case, the loading of toluene per test piece can be reduced following the procedure in Clause 10.

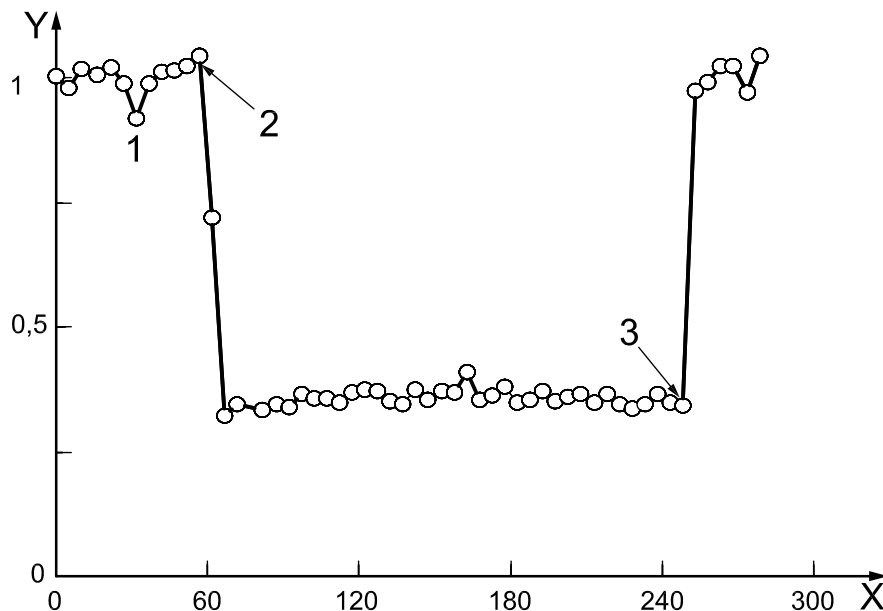

Key

- X time (min)
- Y concentration of toluene ($\mu\text{l/l}$)
- 1 under dark
- 2 irradiation start
- 3 irradiation stop

Figure 4 — Typical trace of toluene concentration during the test operation

8.2 Pretreatment of test piece

Irradiate the test piece with an ultraviolet lamp for at least 16 h (up to 24 h) to decompose residual organic matter on the test piece. The UV irradiance at the sample surface shall be high enough to secure complete decomposition of organic matter (15 W/m^2 or higher). If the test pieces are not to be tested immediately after this pretreatment, they shall be kept in an airtight container.

8.3 Toluene removal test

8.3.1 Adjust the test gas supply beforehand so that it can stably supply the test gas containing $5,0 \mu\text{l/l} \pm 0,25 \mu\text{l/l}$ of toluene and $1,56 \% \pm 0,16 \%$ of volume fraction of water vapour at $25,0 \text{ }^\circ\text{C} \pm 2,5 \text{ }^\circ\text{C}$. This water-vapour volume fraction is equivalent to a relative humidity of 50 % at $25 \text{ }^\circ\text{C}$. The measurement of humidity shall be made using the procedure in ISO 4677-1. Adjust the flow regulator in order for the flow rate at the inlet of the reactor to be $0,5 \text{ l/min}$ ($0 \text{ }^\circ\text{C}$, $101,3 \text{ kPa}$, and dry-gas basis). Measure and record the irradiance from the light source at the surface of the test piece. For the light source that requires warming up, turn the power on well before the measurement of irradiance and irradiation for the toluene removal test. Use the shutter appropriately to avoid unnecessary irradiation to the photoreactor.

8.3.2 Place the test piece in the centre of the photoreactor and attach the glass window after adjusting the air layer between the test piece and window to be $5,0 \text{ mm} \pm 0,5 \text{ mm}$ thick. If necessary, height-adjusting plates are used for this purpose, adjusting the height before and after the test piece to be within $1,0 \text{ mm}$ difference based on the top of the test piece. Check that the reactor is sealed by visual examination of the sealing material, such as an O-ring to tightly contact the glass window.

8.3.3 Allow the test gas to flow into the photoreactor, without photoirradiation. The flow rate shall be $0,5 \text{ l/min}$. Record the change in the concentrations of toluene under dark conditions for 30 min. Adsorption of toluene onto the test piece can be observed by this procedure. When the concentration at the outlet of the reactor returns to the supply gas concentration within 30 min, photoirradiation may be started at the time. If the toluene concentration is less than 90 % of the concentration supplied, continue until it exceeds this. If the concentration does not exceed 90 % after 90 min, stop measurement and report that this test is not applicable to the test piece used.

8.3.4 Maintain the gas to flow and commence irradiation of the test piece, and record the concentration of toluene under photoirradiation for 3 h. The concentration decreases, as shown in Figure 4, if toluene is decomposed by a photocatalyst and then stabilizes. The concentration of toluene at the outlet of the photoreactor should be the average of 3 or more measurements in the last 1 h testing period. If the relative standard deviation of the last 3 measurements exceeds 20 %, report this instability with possible reasons, such as deactivation of the test piece.

8.3.5 Stop photoirradiation and confirm that the concentration of toluene returns to supply gas concentration. Stop the gas supply to the reactor and take the test piece out of the reactor.

9 Calculation

The test results shall be calculated as follows. The calculated values are usually rounded to one decimal place in accordance with ISO 80000-1. The observed concentration of toluene before water-vapour correction shall be used for calculation. The flow rate of the test gas f is $0,5 \text{ (l/min)}$, normalized for $0 \text{ }^\circ\text{C}$, $101,3 \text{ kPa}$ and dry-gas basis, and is then multiplied by a factor of $1,016$ for water-vapour correction.

The removal percentage of toluene (R) is calculated by Equation (1). When R is either below 5 % or more than 95 %, it is expressed as "below 5 %" or "more than 95 %", respectively. Then the quantity of toluene removed (n_T) is calculated by Equation (2). When n_T is either below 5 % or more than 95 %, it is expressed as "below 5 %" or "more than 95 %", respectively.

$$R = \frac{\phi_{T0} - \phi_T}{\phi_{T0}} \times 100 \quad (1)$$

$$n_T = R \times \frac{\phi_{T0} \times f \times 1,016 \times 60}{100 \times 22,4} \quad (2)$$

where

- R is the removal percentage, by test piece, of toluene;
- ϕ_{T0} is the supply volume fraction of toluene, in microlitres per litre ($\mu\text{l/l}$);
- ϕ_T is the toluene volume fraction at the reactor exit, in microlitres per litre ($\mu\text{l/l}$);
- n_T is the quantity of toluene removed by the test piece, in micromoles (μmol);
- f is the flow rate of test gas converted into that at the standard state (0,5 l/min, 0 °C, 101,3 kPa, and dry-gas basis).

10 Test method for test pieces with lower performance

In the case where the removal percentage is less than 5 % and a more certain result is demanded, the number of test pieces may be altered as shown in Table 1. However, the removal quantity of toluene to appear in the test report shall be half of the value calculated from Equation (2).

Table 1 — Alternative test conditions

Alterable test conditions	Value after change
Number of test pieces	2 pieces in series (surface of 50 mm × 200 mm)

11 Test report

The test report shall include the reporting provisions of ISO/IEC 17025, and shall include the following information. Items g), h) and i) shall be reported for each test.

- The name and address of the testing establishment.
- The date of the test, a unique identification of the report and of each page, the customer's name and address, signatory of the report.
- A reference to this part of ISO 22197, i.e. determined in accordance with ISO 22197-3:2011.
- Date of test, atmospheric temperature, relative humidity, etc.
- A description of the test piece (material, size, shape, etc.).
- A description of test equipment (specifications, etc.).
- Testing conditions (kind of pollutant gas, supply concentration, water-vapour concentration, flow rate, detailed description of light source, irradiance, analyser and radiometer used, conditions of pretreatment, modification under Clause 10, etc.).
- The amount of toluene removed during the last 1 h, and removal percentage of toluene (optional). If the test is not valid, the reasons for that (e.g. strong adsorption of toluene).
- Any other matters of special importance, such as a change in the test piece noticed during the test.

Annex A (informative)

Results of round-robin test

A round-robin test was undertaken between six collaborating laboratories. Each laboratory (lab) prepared the test equipment, including the photoreactor, separately. The organizing laboratory visited each party during the test with a standard gas cylinder (about 1 µl/l toluene in nitrogen), calibrated gas flowmeter and UV-A radiometer to check and calibrate its equipment. Each laboratory made four tests using the sheet- and filter-type photocatalyst supplied. The original data are shown in Table A.1.

Table A.1 — Results of round-robin test

Unit: micromoles (µmol)

Test piece	Run	Lab A	Lab B	Lab C	Lab D	Lab E	Lab F
Sheet-type	1	0,81	0,91	0,85	0,93	0,87	0,86
	2	0,89	0,91	0,87	0,94	0,79	0,89
	3	0,84	0,94	0,86	0,91	0,82	0,87
	4	0,79	0,91	0,85	0,92	0,82	0,92
Filter-type	1	1,31	1,22	1,17	1,21	1,25	—
	2	1,31	1,19	1,13	1,19	1,23	—
	3	1,29	1,18	1,23	1,21	1,29	—
	4	1,31	1,15	1,21	1,18	1,25	—

The overall mean, repeatability standard deviation and reproducibility standard deviation computed in accordance with ISO 5725-2 are summarized in Table A.2.

Table A.2 — Statistical data obtained in accordance with ISO 5725-2

Unit: micromoles (µmol)

Test piece	Overall mean	Repeatability standard deviation	Reproducibility standard deviation
Sheet-type	0,87	0,03 (3,0 %)	0,05 (5,5 %)
Filter-type	1,23	0,03 (2,2 %)	0,06 (4,8 %)
Relative standard deviations are shown in parentheses.			

In further tests, the results obtained with different photocatalyst samples, such as sheet glass, paper, fabrics, paint, etc., varied from < 0,2 µmol to 2,4 µmol, which indicated that this method can differentiate the samples with different photocatalytic performance.

Bibliography

- [1] ISO 4892-1, *Plastics — Methods of exposure to laboratory light sources — Part 1: General guidance*
- [2] ISO 16000-3:2001, *Indoor air — Part 3: Determination of formaldehyde and other carbonyl compounds — Active sampling method*
- [3] FUJISHIMA, A., HASHIMOTO, K. and WATANABE, T. *TiO₂ Photocatalysis. Fundamentals and Applications*, BKC Inc., Tokyo (1999)
- [4] OBEE, T.N. Photooxidation of Sub-Parts-per-Million Toluene and Formaldehyde Levels on Titania Using a Glass-Plate Reactor, *Environ. Sci. Technol.* **30**, pp. 3578-3584 (1996)
- [5] CAO, L., GAO, Z., SUIB, S.L., OBEE, T.N., HAY, S.O. and FREIHAUT, J.D. Photocatalytic Oxidation of Toluene on Nanoscale TiO₂ catalysts: Studies of Deactivation and Regeneration, *J. Catal.* **196**, pp. 253-261 (2000)
- [6] BLOUNT, M.C. and FALCONER, J.L. Steady-state Surface Species during Toluene Photocatalysis, *Appl. Catal. B: Environ.* **39**, pp. 39-50 (2002)
- [7] MÉNDEZ-ROMÁN, R. and CARDONA-MARTÍNEZ, N. Relationship between the Formation of Surface Species and Catalyst Deactivation during the Gas-phase Photocatalytic Oxidation of Toluene, *Catal. Today*, **40**, pp. 353-365 (1998)

www.iso.org

ICS 81.060.30

Price based on 11 pages