**Intelligent transport systems — Full
speed range adaptive cruise control
(FSRA) systems — Performance
requirements and test procedures**

*Systèmes intelligents de transport — Systèmes de commande de
croisière adaptatifs à la gamme entière de vitesse (FSRA) — Exigences
de performance et méthodes d'essai*



PDF disclaimer

This PDF file may contain embedded typefaces. In accordance with Adobe's licensing policy, this file may be printed or viewed but shall not be edited unless the typefaces which are embedded are licensed to and installed on the computer performing the editing. In downloading this file, parties accept therein the responsibility of not infringing Adobe's licensing policy. The ISO Central Secretariat accepts no liability in this area.

Adobe is a trademark of Adobe Systems Incorporated.

Details of the software products used to create this PDF file can be found in the General Info relative to the file; the PDF-creation parameters were optimized for printing. Every care has been taken to ensure that the file is suitable for use by ISO member bodies. In the unlikely event that a problem relating to it is found, please inform the Central Secretariat at the address given below.



COPYRIGHT PROTECTED DOCUMENT

© ISO 2009

All rights reserved. Unless otherwise specified, no part of this publication may be reproduced or utilized in any form or by any means, electronic or mechanical, including photocopying and microfilm, without permission in writing from either ISO at the address below or ISO's member body in the country of the requester.

ISO copyright office
Case postale 56 • CH-1211 Geneva 20
Tel. + 41 22 749 01 11
Fax + 41 22 749 09 47
E-mail copyright@iso.org
Web www.iso.org

Published in Switzerland

Contents

Page

Foreword	iv
Introduction.....	v
1 Scope	1
2 Normative references	1
3 Terms and definitions	1
4 Symbols and abbreviated terms	3
5 Classification	4
6 Requirements.....	5
6.1 Basic control strategy.....	5
6.2 Functionality	5
6.3 Basic driver interface and intervention capabilities	9
6.4 Operational limits	10
6.5 Activation of brake lights.....	12
6.6 Failure reactions.....	12
7 Performance evaluation test methods	13
7.1 Environmental conditions	13
7.2 Test target specification	13
7.3 Automatic “stop” capability test.....	14
7.4 Target acquisition range test	15
7.5 Target discrimination test.....	16
7.6 Curve capability test	18
Annex A (normative) Technical information	21
Bibliography.....	27

Foreword

ISO (the International Organization for Standardization) is a worldwide federation of national standards bodies (ISO member bodies). The work of preparing International Standards is normally carried out through ISO technical committees. Each member body interested in a subject for which a technical committee has been established has the right to be represented on that committee. International organizations, governmental and non-governmental, in liaison with ISO, also take part in the work. ISO collaborates closely with the International Electrotechnical Commission (IEC) on all matters of electrotechnical standardization.

International Standards are drafted in accordance with the rules given in the ISO/IEC Directives, Part 2.

The main task of technical committees is to prepare International Standards. Draft International Standards adopted by the technical committees are circulated to the member bodies for voting. Publication as an International Standard requires approval by at least 75 % of the member bodies casting a vote.

Attention is drawn to the possibility that some of the elements of this document may be the subject of patent rights. ISO shall not be held responsible for identifying any or all such patent rights.

ISO 22179 was prepared by Technical Committee ISO/TC 204, *Intelligent transport systems*.

.....

Introduction

The main system function of full speed range adaptive cruise control (FSRA) is to control vehicle speed adaptively to a forward vehicle by using information about:

- a) distance to forward vehicles,
- b) the motion of the subject (FSRA equipped) vehicle, and
- c) driver commands (see Figure 1).

Based upon the information acquired, the controller (identified as “FSRA control strategy” in Figure 1) sends commands to actuators that carry out its longitudinal control strategy, and sends status information to the driver.

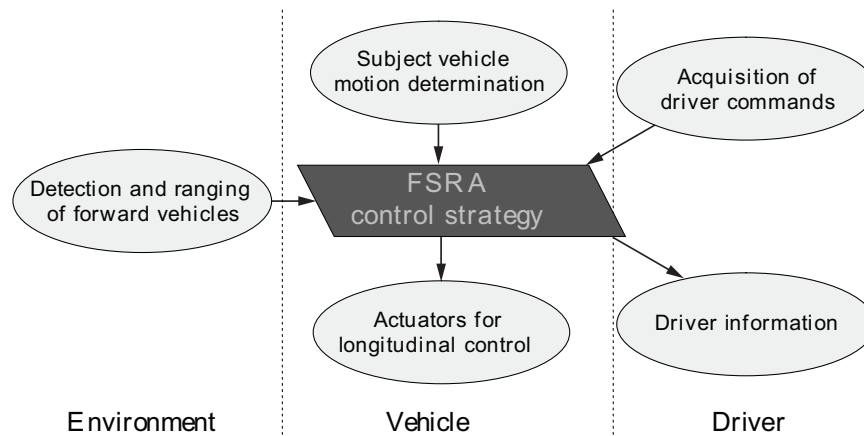

Figure 1 — Functional FSRA elements

The goal of FSRA is partial automation of longitudinal vehicle control to reduce drivers' workload.

This International Standard may be used as a system level standard by other standards, which extend FSRA to a more detailed standard, e.g. for specific detection and ranging-sensor concepts or higher levels of functionality. Issues such as specific requirements for the detection and ranging sensor function and performance or communication links for co-operative solutions are not considered in this International Standard.

Intelligent transport systems — Full speed range adaptive cruise control (FSRA) systems — Performance requirements and test procedures

1 Scope

This International Standard contains the basic control strategy, minimum functionality requirements, basic driver interface elements, minimum requirements for diagnostics and reaction to failure, and performance test procedures for full speed range adaptive cruise control (FSRA) systems. FSRA is fundamentally intended to provide longitudinal control of equipped vehicles while travelling on highways (roads where non-motorized vehicles and pedestrians are prohibited) under free-flowing and congested traffic conditions. FSRA provides support within the speed domain of standstill up to the designed maximum speed of the system. The system will attempt to stop behind an already tracked vehicle within its limited deceleration capabilities and will be able to start again after the driver has input a request to the system to resume the journey from standstill. The system is not required to react to stationary or slow moving objects {in accordance with ISO 15622 [adaptive cruise control (ACC)]}.

2 Normative references

The following referenced documents are indispensable for the application of this document. For dated references, only the edition cited applies. For undated references, the latest edition of the referenced document (including any amendments) applies.

ISO 2575, *Road vehicles — Symbols for controls, indicators and tell-tales*

3 Terms and definitions¹⁾

For the purposes of this document, the following terms and definitions apply.

3.1

active brake control

function that causes application of the brake(s), not applied by the driver, in this case controlled by the FSRA system

3.2

adaptive cruise control

ACC

enhancement to conventional cruise control systems (see 3.5) which allows the subject vehicle to follow a forward vehicle at an appropriate distance by controlling the engine and/or power train and potentially the brake

3.3

brake

part in which the forces opposing the movement of the vehicle develop

1) Definitions are in accordance with the glossary of ISO/TC 204/WG 14.

EXAMPLE Brakes can be of the following types: a friction brake (where forces are generated by friction between two parts of the vehicle moving relatively to one another); an electrical brake (where forces are generated by electromagnetic action between two parts of the vehicle moving relatively but not in contact with one another); a fluid brake (where forces are generated by the action of a fluid situated between two parts of the vehicle moving relatively to one another); or an engine brake (where forces are derived from an artificial increase in the braking action of the engine, transmitted to the wheels).

NOTE Definition adapted from ECE-R 13-H, except that for the purposes of this International Standard, transmission control devices are not considered as brakes.

**3.4
clearance**

distance from the forward vehicle's trailing surface to the subject vehicle's leading surface

**3.5
conventional cruise control**

system capable of controlling the speed of a vehicle as set by the driver

**3.6
forward vehicle**

vehicle in front of, and moving in the same direction and travelling on the same roadway as, the subject vehicle

**3.7
free-flowing traffic**

smooth flowing and heavy traffic excluding stop-and-go and emergency braking situations

**3.8
time gap, τ**

time gap calculated as clearance, c , divided by vehicle speed, v

NOTE See Figure 2.

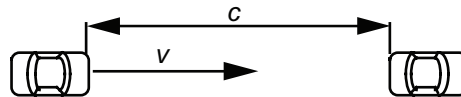

Key

c clearance

v vehicle speed

NOTE $\tau = c/v$

Figure 2 — Time gap

**3.9
set speed**

desired travel speed, set by either the driver or by some control system that is external to the FSRA system

NOTE The set speed is the maximum desired speed of the vehicle while under FSRA control.

**3.10
steady state**

condition whereby the value of the described parameter does not change with respect to time, distance, etc.

**3.11
subject vehicle**

vehicle equipped with the FSRA system in question and related to the topic of discussion

3.12**system state**

one of several stages or phases of system operation

NOTE See Figure 3.

3.12.1**FSRA off state**

direct access for activation of FSRA active state (3.12.3) is disabled

3.12.2**FSRA stand-by state**

state in which there is no longitudinal control by FSRA system and the system is ready for activation by the driver

3.12.3**FSRA active state**

state in which the system controls speed and/or clearance

3.12.4**FSRA hold state**

state in which the system is active during subject vehicle standstill

3.12.5**FSRA speed control state**

state in which the system controls the speed according to the set speed

3.12.6**FSRA following control state**

state in which the system controls the clearance to the target vehicle according to the selected time gap

3.13**stationary object**

stationary object in front of the subject vehicle

3.14**slow moving object**

object in front of the subject vehicle that is moving with less than MAX [1 m/s, 10 % of subject vehicle speed] in the direction of the centreline of the subject vehicle

3.15**target vehicle**

vehicle that the subject vehicle follows

3.16**full speed range adaptive cruise control**

enhancement to adaptive cruise control systems (3.2), which allows the subject vehicle to follow a forward vehicle at an appropriate distance by controlling the engine and/or power train and the brake down to standstill

4 Symbols and abbreviated terms

$a_{\text{lateral_max}}$	Maximum allowed lateral acceleration in curves
a_{stopping}	longitudinal acceleration of the target vehicle at the automatic "stop" capability test
CTT	coefficient for test target, for infrared reflectors
c	clearance, inter-vehicle distance
c_{min}	minimum clearance under steady state conditions for all speeds (including hold state)

d_0	distance, below which detection of a target vehicle is not required
d_1	distance, below which neither distance measurement nor determination of relative speed is required
d_2	distance for measurement purposes
d_{\max}	maximum detection range on straight roads
LIDAR	light detection and ranging
R	circle radius, curve radius
R_{\min}	minimum curve radius
RCS	radar cross section
v	the true subject vehicle speed over ground
v_{circle}	maximum speed on a curve for a given lateral acceleration $a_{\text{lateral_max}}$
$v_{\text{circle_start}}$	vehicle speed as it enters a curve of radius R
$v_{\text{set_max}}$	maximum selectable set speed
$v_{\text{set_min}}$	minimum selectable set speed
v_{stopping}	vehicle speed of the target vehicle at the automatic “stop” capability test
$v_{\text{vehicle_end}}$	vehicle speed at the end of a test
$v_{\text{vehicle_max}}$	maximum vehicle speed
$v_{\text{vehicle_start}}$	vehicle speed at the start of a test
τ	time gap between vehicles
τ_{\max}	maximum selectable time gap
$\tau_{\max}(v)$	maximum possible steady-state time gap at a given speed v
τ_{\min}	minimum selectable time gap

5 Classification

This International Standard permits FSRA systems of different curve capabilities as specified in Table 1.

Table 1 — FSRA performance classifications

Dimensions in meters

Performance Class	Curve radius capability
I	Reserved for ACC ISO 15622, not applicable for FSRA
II	≥ 500
III	≥ 250
IV	≥ 125

6 Requirements

6.1 Basic control strategy

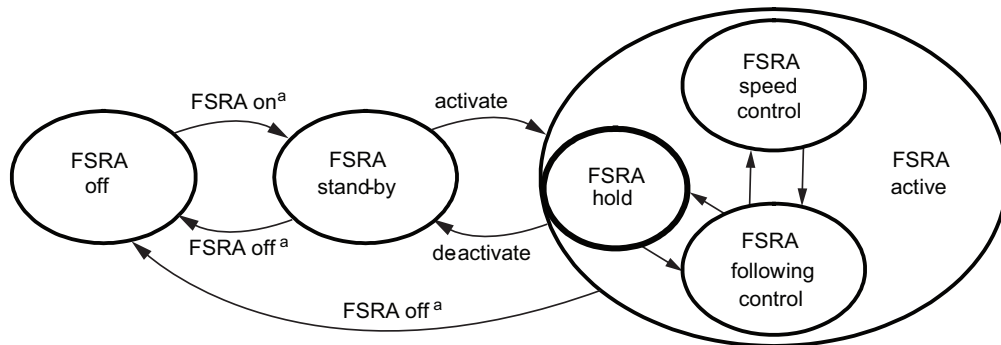

System states are indicated by the text contained in ellipses.

NOTE Manual transition describes a switch to enable/disable FSRA function. Automatic switch-off can be forced by failure reaction.

^a This is manual and/or automatic after self-test.

Figure 3 — FSRA states and transitions

FSRA systems shall, as a minimum, provide the following control strategy and state transitions. The following constitutes the fundamental behaviour of FSRA systems.

- When the FSRA is active, the vehicle speed shall be controlled automatically either to maintain a clearance to a forward vehicle, or to maintain the set speed, whichever speed is lower. The change between these two control modes is made automatically by the FSRA system.
- The steady-state clearance may be either self adjusting by the system or adjustable by the driver (see 6.3.1).
- If there is more than one forward vehicle the one to be followed shall be selected automatically (see 6.2.3.3).
- The state shall change from following control to hold state within a time period not to exceed 3 s after the subject vehicle has come to a stop.
- In the “hold” state, the automatic brake control shall be used for keeping the subject vehicle stationary.

6.2 Functionality

6.2.1 Control modes

The transition between the control modes (following controlled or speed controlled) shall be made automatically.

6.2.2 Stationary or slow moving targets

The system will attempt to stop behind an already tracked and stopping vehicle within its limited deceleration capabilities. It is optional to design FSRA systems to respond to the presence of stationary or slow moving targets. If a given implementation is not intended to respond to stationary or slow moving targets, the driver shall be informed at least by a statement in the vehicle owner's manual.

6.2.3 Following capability

τ_{\min} shall be the minimum selectable time gap for following control mode under steady-state conditions for all speeds v . τ_{\min} shall be greater than or equal to 1 s.

c_{\min} shall be the minimum clearance for following control mode under steady-state conditions for all speeds v (including hold state). c_{\min} shall be greater than or equal to 2 m.

Under steady state conditions the minimum clearance shall be $\text{MAX}(c_{\min}, \tau_{\min} \times v)$. Under transient conditions, the clearance may temporarily fall below the minimum clearance. If such a situation occurs, the system shall adjust the clearance to attain the desired clearance.

At least one time gap setting, τ , in the range of 1,5 s to 2,2 s shall be provided for speeds higher than 8 m/s.

As a minimum requirement, the system shall be able, starting from steady state following, to stop behind a gradually stopping vehicle which is decelerating with a_{stopping} at a speed below v_{stopping} (see the test procedure given in 7.3.2).

$$v_{\text{stopping}} = 10 \text{ m/s}$$

$$a_{\text{stopping}} = 2,5 \text{ m/s}^2$$

6.2.3.1 The FSRA shall have detection range, target discrimination and curve capabilities as specified below.

6.2.3.2 Detection range on straight roads (performance classes II, III and IV).

If a forward vehicle is present within the distance range d_1 to d_{\max} , the FSRA system shall measure the range between the forward and subject vehicles (see Figure 4). Within this range, the forward vehicle shall be detected within a lateral area of at least the subject vehicle width.

$$d_{\max} = \tau_{\max}(v_{\text{set_max}}) \times v_{\text{set_max}}$$

If a forward vehicle is present within the distance range d_0 to d_1 , the FSRA system shall detect the presence of the vehicle but is not required to measure the range to the vehicle nor the relative speed between the forward and subject vehicles.

$$d_1 = 4 \text{ [m]}$$

If a forward vehicle is present at a distance less than d_0 , the FSRA system is not required to detect the presence of the vehicle.

$$d_0 = 2 \text{ [m]}$$

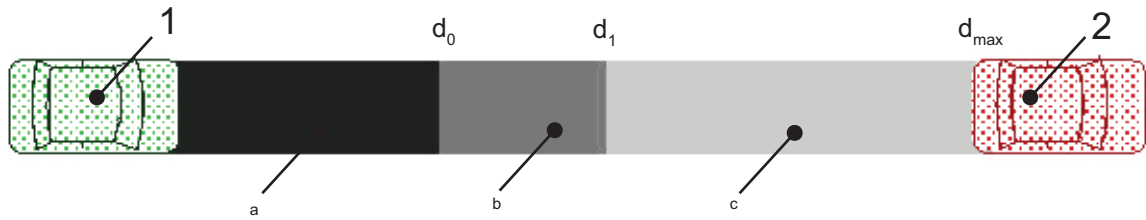

Key

- 1 subject vehicle
- 2 forward vehicle
- a Detection is not required.
- b Detection of vehicles required.
- c Determination of range required.

Figure 4 — Zones of detection

6.2.3.3 Target discrimination

If there is more than one forward vehicle on straight roads and for performance classes II, III and IV also in steady state curves, the forward vehicle (refer to Figure 5) in the subject vehicle's path shall be selected for FSRA control in typical FSRA situations as represented by the test scenario (see 7.5 Target discrimination test).

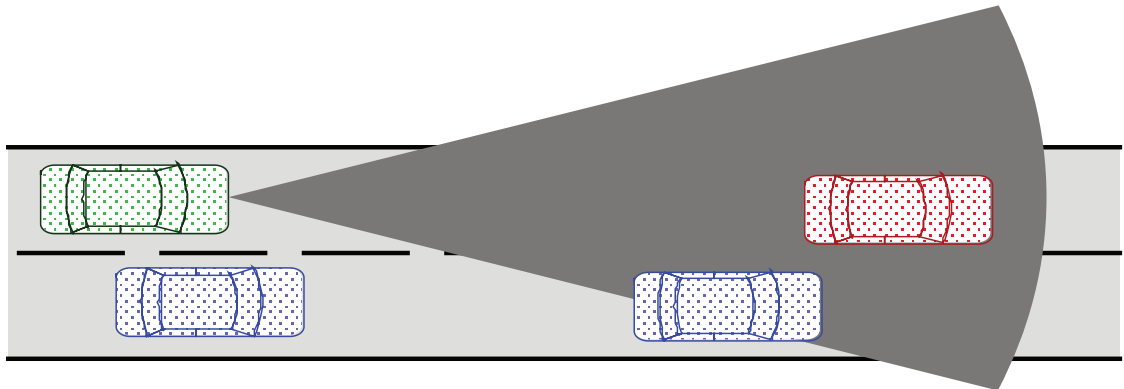

Figure 5 — Target discrimination

6.2.3.4 Curve capability (performance classes II, III and IV)

The FSRA system shall enable steady state vehicle following with a time gap of $\tau_{max}(v_{circle})$, on straight roads (classes II, III and IV) and curves with a radius down to $R_{min,II} = 500$ m (classes II, III and IV) and $R_{min,III} = 250$ m (classes III and IV) and $R_{min,IV} = 125$ m (class IV). Therefore the system shall be capable of following a forward vehicle with the steady state time gap $\tau_{max}(v_{circle})$, if the forward vehicle cruises on a constant curve radius R_{min} with a constant speed v_{circle} .

$$v_{circle} = \sqrt{a_{lateral_max} * R_{min}}$$

where

$\tau_{max}(v)$ is the maximum possible steady state time gap while driving with a speed v on a straight;

$a_{lateral_max}$ is the design lateral acceleration for curves on highways.

The values to use are

$a_{lateral_max,II} = 2,0$ m/s², and

$a_{lateral_max,III} = 2,3$ m/s², and

$a_{lateral_max,IV} = 2,3$ m/s².

The values for $a_{lateral_max}$ are derived from average driver behaviour in curves (95 % of drivers) {see Figure 6 and Reference [3]}.

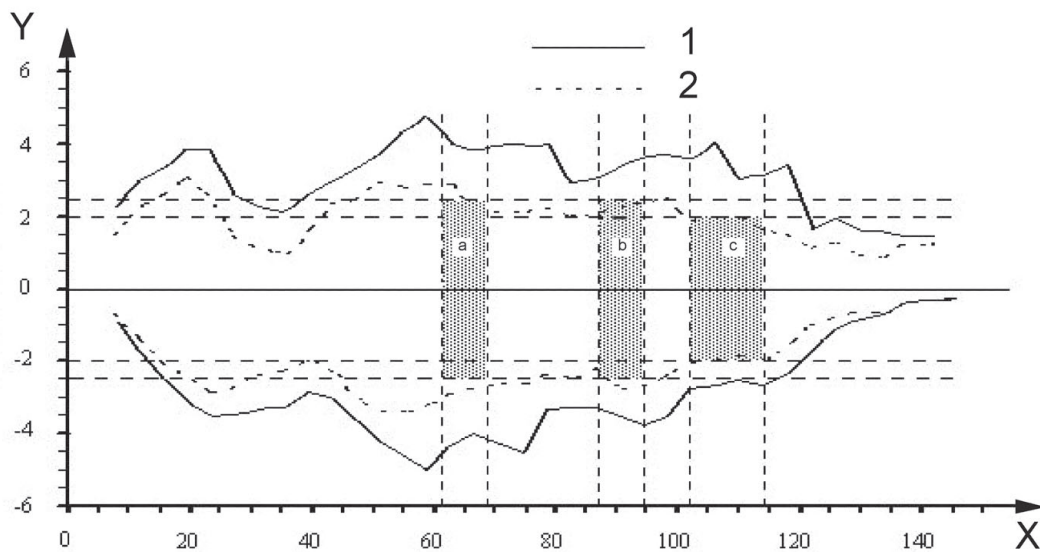

Key

- | | | | |
|---|--|---|------------|
| 1 | maximum value | a | Class IV. |
| 2 | 95 % zone | b | Class III. |
| X | subject vehicle speed (km/h) | c | Class II. |
| Y | lateral acceleration (m/s ²) | | |

Figure 6 — Lateral acceleration of the average driver

6.2.4 “Go” transition (driver-initiated “go”)

The transition from hold to following control or speed control shall not be enabled without a driver’s request.

6.3 Basic driver interface and intervention capabilities

6.3.1 Operation elements and system reactions

6.3.1.1 FSRA systems shall provide a means for the driver to select a desired set speed.

6.3.1.2 In the FSRA following control and FSRA speed control states, braking by the driver shall deactivate the FSRA function, at least if the driver initiated brake force demand is higher than the FSRA initiated brake force. In the FSRA hold state, it is not mandatory that braking by the driver deactivates the FSRA system [leading to FSRA standby state (see Figure 3)].

6.3.1.3 The FSRA system shall not lead to a significant transient reduction of braking response to the driver’s braking input (see ECE-R 13-H) even when the FSRA-system has been braking automatically.

6.3.1.4 The larger of the power demands from either the driver or the FSRA system will be used to drive the engine power actuator (e.g. throttle actuator). This always gives the driver authority to override the FSRA system engine power control. If the power demand of the driver is greater than that of the FSRA system automatic braking shall be disengaged with an immediate brake force release. A driver intervention on the accelerator pedal shall not lead to a significant delay of response to driver’s input.

6.3.1.5 Automatic brake activation shall not lead to locked wheels for periods longer than anti-lock devices (ABS) would allow. This requirement applies whether or not an ABS system is fitted.

6.3.1.6 Automatic power control by FSRA shall not lead to excessive positive wheel slip for periods longer than traction control would allow. This requirement applies whether or not a traction control system is fitted.

6.3.1.7 FSRA systems may automatically adjust the clearance without action by the driver in order to respond to the driving environment (i.e. poor weather). However, the adjusted clearance shall not be less than the minimum clearance selected by the driver.

6.3.1.8 If the system allows the driver to select a desired time gap, the selection method shall conform to either one of the following:

- a) If the system retains the last selected time gap after it is switched to FSRA OFF, as shown in Figure 3, the time gap shall be clearly presented to the driver at least upon system activation.
- b) If the system does not retain the last selected time gap after it is switched to FSRA OFF, as shown in Figure 3, the time gap shall be set to a predefined default value greater than or equal to 1,5 s.

6.3.1.9 If there is a conventional cruise control function in addition to FSRA there shall be no automatic switching between the FSRA and conventional cruise control.

6.3.1.10 Optionally, the system may be activated by the driver at standstill even when the driver is applying the brake pedal.

6.3.2 Display elements

- a) A minimum feedback information for the driver contains activation state (FSRA system is active or not active) and the set speed. This can be done by a combined output, e.g. displaying of set speed information only when FSRA is active.
- b) If the FSRA system is not available due to a failure, the driver shall be informed. If a symbol is used to notify the driver, a standard symbol shall be employed (see 6.3.3).

- c) If the FSRA system deactivates automatically, the driver shall be informed. If a symbol is used to notify the driver, a standard symbol shall be employed (see 6.3.3).
- d) If the vehicle is equipped with both FSRA and conventional cruise control systems, the driver shall be made aware of which system is operating.
- e) A “vehicle-detected” signal, with the meaning that the active FSRA system is detecting a forward vehicle, is required to be active if this forward vehicle is used for adaptation of the control.

6.3.3 Symbols

If symbols are used to identify FSRA function or malfunction, standardized symbols in accordance with ISO 2575 shall be used.

6.4 Operational limits

To promote comfort, below 5 m/s there shall not be a sudden brake force release due to a disappearing target vehicle or an automatic deactivation due to a system failure other than brake failures.

The minimum set speed shall be $v_{set_min} \geq 7$ m/s.

The average automatic deceleration of FSRA systems shall not exceed 3,5 m/s² (average over 2 s) when the vehicle is travelling above 20 m/s, and 5 m/s² (average over 2 s) when the vehicle is travelling below 5 m/s, as shown in Figure 7.

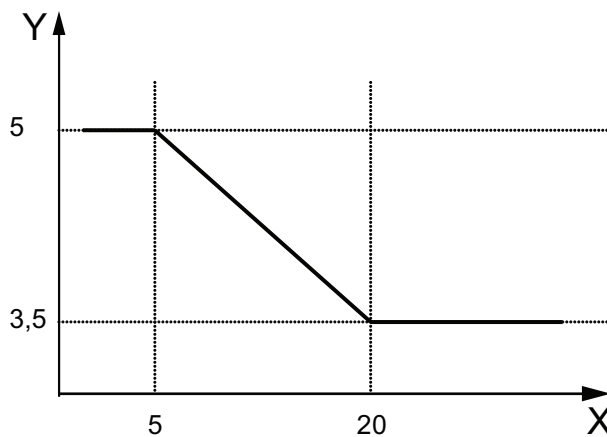

Key

- X subject vehicle speed (m/s)
- Y maximum deceleration (m/s²)

Figure 7 — Maximum deceleration

The average rate of change of automatic deceleration (negative jerk) shall not exceed 2,5 m/s³ (average over 1 s) when the vehicle is travelling above 20 m/s, and 5 m/s³ (average over 1 s) when the vehicle is travelling below 5 m/s, as shown in Figure 8.

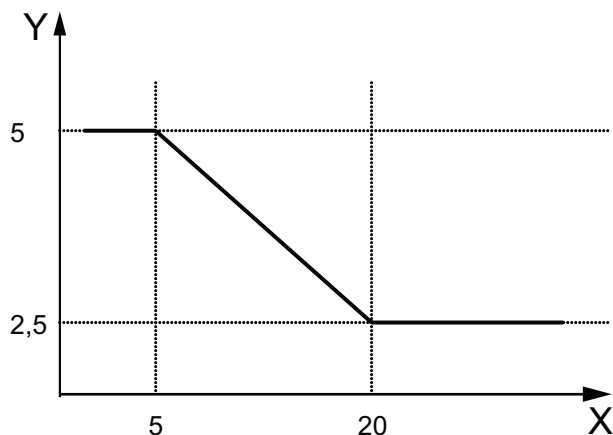

Key

- X subject vehicle speed (m/s)
- Y negative jerk (m/s³)

Figure 8 — Maximum negative jerk

The average automatic acceleration of FSRA systems shall not exceed 2 m/s² (average over 2 s) when the vehicle is travelling above 20 m/s and 4 m/s² (average over 2 s) when the vehicle is travelling below 5 m/s, as shown in Figure 9.

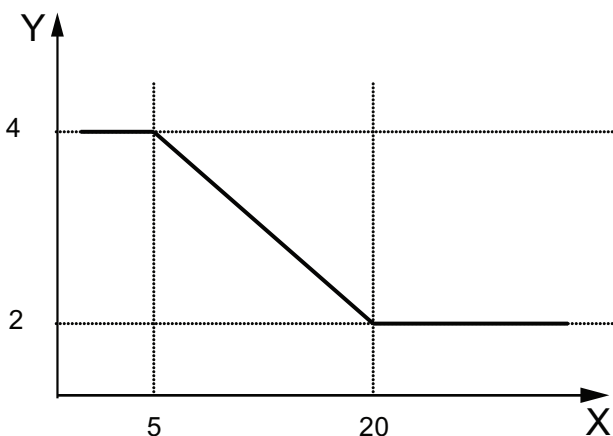

Key

- X subject vehicle speed (m/s)
- Y automatic acceleration (m/s²)

Figure 9 — Maximum acceleration

If the target vehicle comes closer than d_0 and is no longer detected, the system should initiate a controller strategy starting with the last valid braking command, until the subject vehicle is stopped or the system detects a forward vehicle within d_1 or the driver overrides the system via accelerator pedal. If a forward vehicle is detected within the distance range d_0 to d_1 and the distance can not be determined, the system shall inhibit automatic acceleration.

6.5 Activation of brake lights

If the FSRA system applies automatic service braking, the brake lights shall be illuminated. When the FSRA system applies other deceleration devices, the system may illuminate the brake lights. The brake lights shall be illuminated within 350 ms after the FSRA system initiated the service brake. To prevent irritating brake light flickering, the brake light may remain on for a reasonable time after the FSRA initiated braking has ended.

6.6 Failure reactions

- a) Table 2 gives the required reactions to failures depending on which subsystem fails (see also Figure 10).
- b) The failures described in Table 2 shall result in immediate notification to the driver. The notification shall remain active until the system is switched off.
- c) The reactivation of the FSRA system shall be prohibited until a successful self-test, e.g. initiated by ignition off/on or FSRA-off/on, is accomplished.

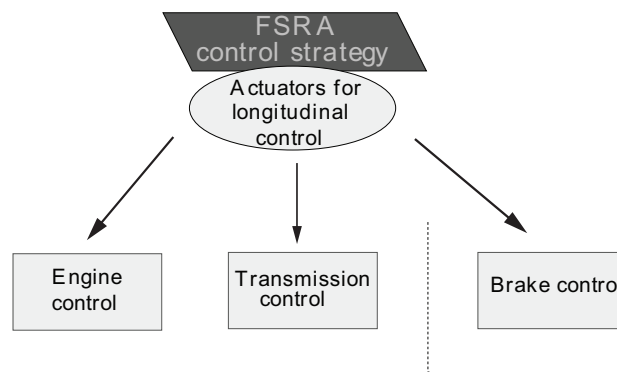

Figure 10 — Actuators for longitudinal control

Table 2 — Failure reactions for FSRA

Failure in subsystem		Failure occurs whilst FSRA is applying	
		Brake control	Engine control
1	Engine	Should maintain braking as required at least for the actual/current braking manoeuvre.	FSRA engine control shall be relinquished.
2	Brake system ^a	FSRA control shall be relinquished. If the brake system failure is not total during an active brake manoeuvre, the system may finish the current braking manoeuvre before the FSRA control is relinquished completely.	FSRA engine control shall be relinquished.
3	Detecting and ranging sensor	Should initiate a controller strategy starting with the last valid braking command. Braking shall not be released suddenly in this case. The system shall be switched off immediately after driver intervention by brake or accelerator pedal or FSRA off switch.	FSRA engine control shall be relinquished.
4	FSRA controller	FSRA control shall be relinquished.	FSRA control shall be relinquished.
^a If a malfunction within the gear controller occurs, the brake will be able to handle the deceleration function.			

7 Performance evaluation test methods

7.1 Environmental conditions

- a) Test location shall be on an asphalt or concrete surface that is flat, dry and clean.
- b) Temperature range shall be between -20 °C and $+40\text{ °C}$.
- c) Horizontal visibility range shall be greater than 1 km.

7.2 Test target specification

The test targets are specified for technologies used today. For other technologies, representative test targets have to be used.

7.2.1 Infrared LIDAR²⁾

The infrared test target is defined by an infrared coefficient for test target, *CTT*, and the cross section of the test target.

The minimum cross section for test targets A and B is 20 cm^2 .

- Test target A: a diffuse reflector where $CTT = 2,0\text{ m}^2/\text{sr} \pm 10\%$ (see Annex A).
- Test target B: a diffuse reflector where $CTT = 1,0\text{ m}^2/\text{sr} \pm 10\%$.

- 2) The test target is defined by a coefficient of a reflector.
 - Target A represents at least 95 % of all vehicles driving on motorways.
 - Target B represents the reflectivity of a dirty car without any retro reflector.

7.2.2 Millimetre wave radar ³⁾

The radar test target is defined by a radar cross section, *RCS*.

For the frequency range between 20 GHz and 95 GHz:

- test target A: *RCS* shall be 10 m²;
- test target B: *RCS* shall be 3 m².

For significantly different frequency ranges, the radar cross section shall be determined and defined (see Annex A).

7.3 Automatic “stop” capability test

7.3.1 Test target vehicle

The target vehicle shall be equipped with the test target A as defined in 7.2. The test target shall be placed on the rear end of the vehicle. The remaining exposed vehicle surface shall be concealed in such a way that the rear surface, with the test target removed, represents an *RCS* of no greater than 2 m² or a reflectivity of no greater than 20 % of the test target.

7.3.2 Initial conditions

A target vehicle shall travel at a speed of v_{stopping} .

The width of the target vehicle shall be between 1,4 m and 2,0 m.

The subject vehicle cruises behind the target vehicle in a steady-state following-control mode.

The desired time gap shall be the value of τ_{min} during the whole test procedure.

The lateral displacement of the subject vehicle's longitudinal centreline relative to the target vehicle's longitudinal centreline shall be less than 0,5 m (see Figure 11).

3) The test target is defined by a radar cross section, *RCS*:

Target A at present, known frequencies (60 GHz, 77 GHz and 90 GHz) represent at least 95 % of all vehicles driving on motorways.

Target B is representative of a motorcycle.

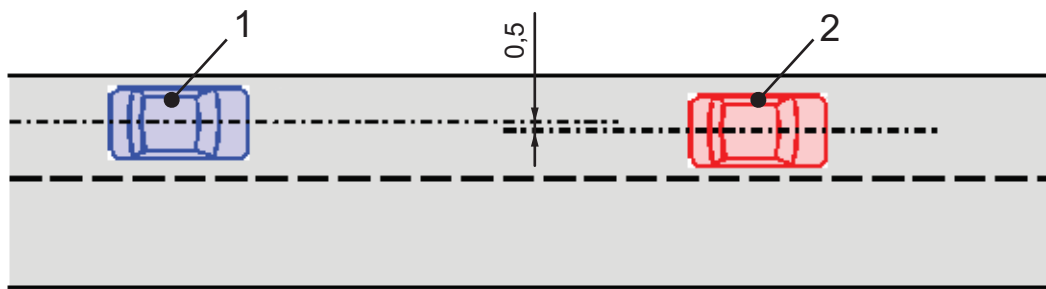
**Key**

- 1 subject vehicle
- 2 target vehicle

Figure 11 — Automatic stop capability test (start conditions)

7.3.3 Test procedure

The target vehicle shall decelerate to stop with a deceleration between $a_{\text{stopping}} \pm 0,5 \text{ m/s}^2$.

The test is considered to be successfully completed when the subject vehicle is stopped by the system behind the preceding vehicle.

7.4 Target acquisition range test

(See 6.2.3.1.)

Test procedure for d_0 , d_1 , d_2 and d_{max} .

The vehicle reference plane corresponds to a rectangle in the height of 0,9 m by subject vehicle-width beginning at a height of 0,2 m. The detection area considers different places within the vehicle front-end plane. It is also restricted by the minimum height of passenger cars. The reference planes of d_1 , d_2 , d_{max} are divided into three columns. The columns L and R have the width of 50 cm each. During testing the defined reflector shall be detected at least at one position within each column (L, C, R) of the vehicle reference plane at the position d_1 , d_2 , d_{max} . At d_0 only one position within the whole reference plane has to be detected (see Figure 12).

- For the position d_{max} , the test target A shall be used.
- For the position d_0 , d_1 and d_2 , the test target B shall be used.
- The d_2 point refers to a fixed measurement point at 75 m in front of the vehicle.
- Range testing should be done while the subject vehicle and the test target are moving. As an option, testing while the subject vehicle and the test target are stationary is permissible.

The maximum target acquisition time should not exceed 2 s after presentation of the target.

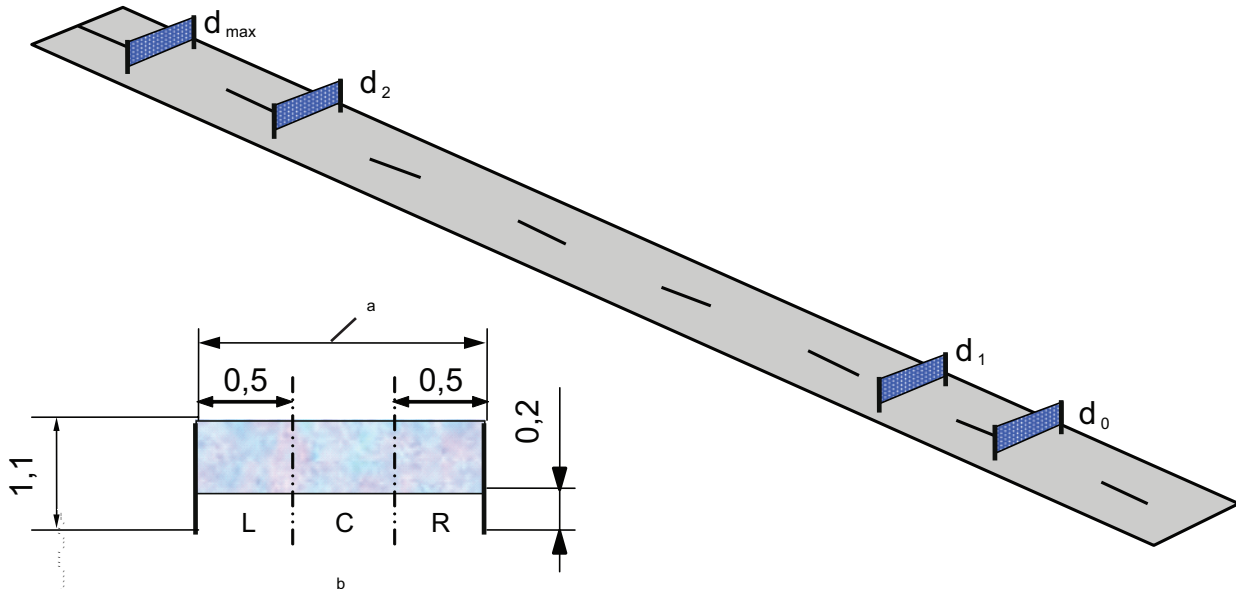

- Key**
- a Subject vehicle width.
 - b Vehicle reference plane.

Figure 12 — Longitudinal detection zone

7.5 Target discrimination test

(See 6.2.3.2.)

7.5.1 Initial conditions

Two forward vehicles of the same model travel along side each other at a speed of $v_{\text{vehicle_start}}$. The spacing between the longitudinal centrelines of the forward vehicles is $3,5 \text{ m} \pm 0,25 \text{ m}$. The width of the forward vehicles shall be between 1,4 m and 2,0 m. The subject vehicle cruises behind one of the forward vehicles in steady state following control mode. The forward vehicle that the subject vehicle follows is designated the target vehicle. The time gap = $\tau_{\text{max}}(v_{\text{vehicle_start}})$ and the set speed $> v_{\text{vehicle_end}}$. The lateral displacement of the longitudinal centreline of the subject vehicle relative to the longitudinal centreline of the target vehicle shall be less than 0,5 m (see Figure 13).

$$v_{\text{vehicle_end}} = 27 \text{ m/s } ^4)$$

NOTE If the vehicle is not capable of this speed, $v_{\text{vehicle_end}} = 22 \text{ m/s}$ (~80 km/h) shall be used.

$$v_{\text{vehicle_start}} = v_{\text{vehicle_end}} - 3 \text{ m/s}$$

4) 27 m/s is approximately 100 km/h.

Dimensions in metres

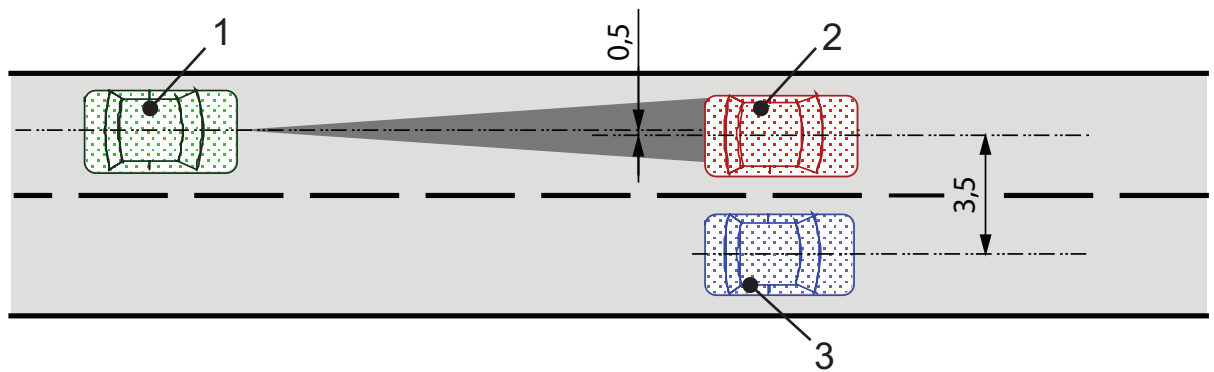

Key

- 1 subject vehicle
- 2 target vehicle
- 3 forward vehicle

Figure 13 — Discrimination test — Start conditions

7.5.2 Test procedure

The target vehicle accelerates to $v_{\text{vehicle_end}}$. The test is successfully fulfilled if the subject vehicle passes the forward vehicle in the adjacent lane while under FSRA control (see Figure 14).

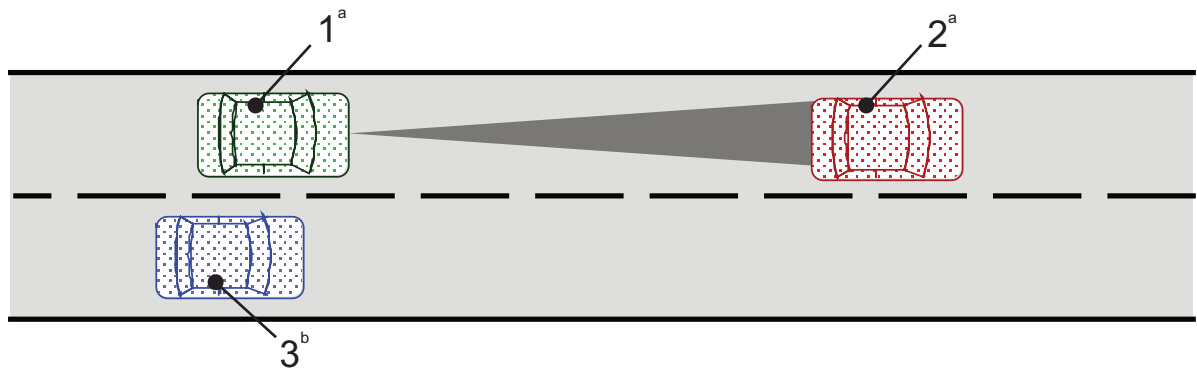

Key

- 1 subject vehicle
 - 2 target vehicle
 - 3 forward vehicle
- a $v = v_{\text{vehicle_end}}$
- b $v = v_{\text{vehicle_start}}$

Figure 14 — Discrimination test — End conditions

7.6 Curve capability test

(See 6.2.3.3.)

This test should take into consideration the road geometry prediction in combination with the field of view of the FSRA system's sensor. Different methods of road geometry prediction and headway sensing result in the need for a driving scenario.

7.6.1 Test field (classes II, III and IV)

The test track shall consist of either a circular track of constant radius or a sufficiently long segment of curve of constant radius. The radius should be within 80 % to 100 % of R_{min} . The direction of travel on the track shall be both clockwise and counter clockwise. There is no restriction concerning lane markings, guard rails, etc. (see Figure 15).

For class II systems, the tests shall be done for $R_{min II} = 500$ m.

For class III systems, the tests shall be done for $R_{min III} = 250$ m.

For class IV systems, the tests shall be done for $R_{min IV} = 125$ m.

Dimensions in metres

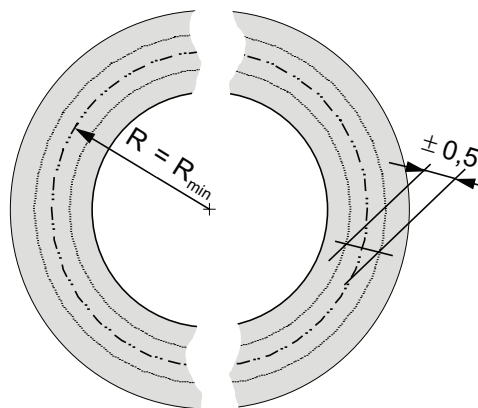

Figure 15 — Outline test track

7.6.2 Curve capability target vehicle

The target vehicle shall be equipped with the test target A, as defined in 7.2. The test target shall be placed in the middle on the rear end of the vehicle at a height of $0,6 \text{ m} \pm 0,1 \text{ m}$ above ground.

The remaining exposed vehicle surface shall be concealed in such a way that the rear surface, with the test target removed, represents an RCS of no greater than 2 m^2 or a reflectivity of no greater than 20 % of the test target.

7.6.3 Driving scenario

The subject vehicle follows the target vehicle along the same path ($\pm 0,5 \text{ m}$ lateral separation as measured from the centrelines of both vehicles) in following control mode. The two cars shall conform to the test start conditions given in Figure 16 prior to the start of the test. Details of the test are given in Table 3 and Figure 16.

The speed of the target vehicle at the start of the test is given by

$$v_{\text{circle_start}} = \text{MIN} [(a_{\text{lateral_max}} * R)^{1/2}, v_{\text{vehicle_max}}] \pm 1 \text{ m/s}$$

where

$$a_{\text{lateral_max}}$$

depends on the curve radius:

$$a_{\text{lateral_max}} = 2,0 \text{ m/s}^2 \text{ when } R = R_{\text{min II}} = 500 \text{ m};$$

$$a_{\text{lateral_max}} = 2,3 \text{ m/s}^2 \text{ when } R = R_{\text{min III}} = 250 \text{ m};$$

$$a_{\text{lateral_max}} = 2,3 \text{ m/s}^2 \text{ when } R = R_{\text{min IV}} = 125 \text{ m}.$$

At the proper time, the target vehicle decelerates and the reaction of the subject vehicle is observed. The subject vehicle shall start to decelerate due to the decreasing distance to the target vehicle before the time gap falls below $2/3 \tau_{\text{max}}$.

Table 3 — Test conditions for the curve capability test

	Test preliminary	Test start conditions	1 st test manoeuvre	2 nd test manoeuvre
Target vehicle				
Speed	$v_{\text{circle_start}} = \text{constant}$		Decrease velocity by 3,5 m/s ± 0,5 m/s	$v_{\text{circle}} = \text{constant} = v_{\text{circle_start}} - (3,5 \pm 1) \text{ m/s}$
Time	Min. 10 s	Time trigger 0 s	2 s	—
Radius	$\geq R$ as defined in 7.6.1; may vary	$R = \text{constant}$ (see 7.6.1)		
Subject vehicle				
Speed	As controlled by FSRA			
Acceleration	$\leq 0,5 \text{ m/s}^2$		Deceleration to be observed	
Radius	$\geq R$ as defined in 7.6.1; may vary	$R = \text{constant}$ (see 7.6.1)		
Time gap to target vehicle	$\tau_{\text{max}} (v_{\text{circle_start}}) \pm 25 \%$		As controlled by FSRA; shall be observed	

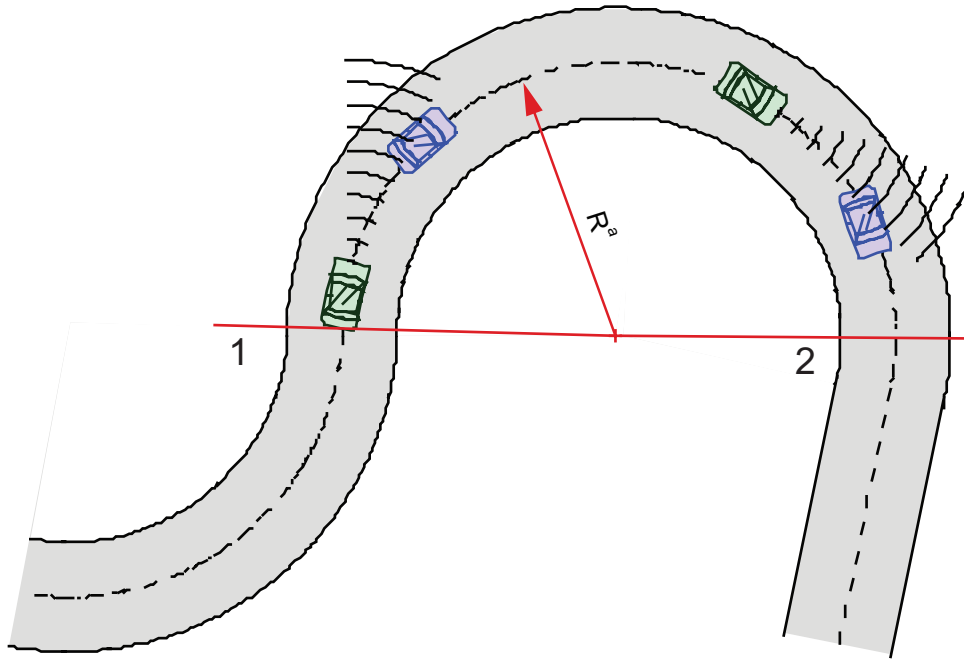

Key

- 1 test start
- 2 test finish

At the test start the subject vehicle shall be on a part of the track with constant radius and shall comply with all requirements given in this subclause.

At the test finish the subject vehicle shall decelerate (positive result) or the time gap shall fall below $2/3 \tau_{\max}$.

^a The radius is constant.

Figure 16 — Example of test track layout

Annex A (normative)

Technical information

A.1 LIDAR — Coefficient of test target

A.1.1 Solid angle

The solid angle, Ω , is the ratio of the irradiated portion of the surface of light to the square of the radius of the sphere (see Figure A.1).

$$\Omega = \frac{A}{d_A^2} \times \Omega_0$$

where

Ω is solid angle, expressed in sr;

A is projected area;

d_A is distance between source and projected area A ;

Ω_0 is solid angle of the source (1 sr).

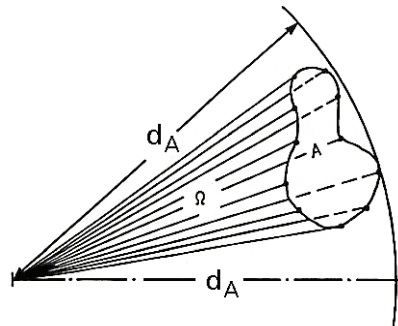

Figure A.1 — Solid angle

A.1.2 Radiated intensity

The radiated intensity, I , is given by the radiated power, Φ , out of a radiation source, inside an area, Ω .

$$I_{\text{ref}} = \frac{d\Phi_{\text{ref}}}{d\Omega_1}$$

where

I_{ref} is radiated intensity in a given direction, out of the reflector, measured in front of the receiver surface expressed in W/sr;

Φ_{ref} is radiated power expressed in W;

Ω_1 is illuminated solid angle expressed in sr.

A.1.3 Intensity of irradiation

Intensity of irradiation, E , is the ratio of the incident radiated power to the area of illuminated surface. E is the density by surface of the illumination.

$$E_t = \frac{d\Phi_t}{dA_t}$$

where

E_t is intensity of irradiation, expressed in W/m²;

A_t is illuminated surface;

Φ_t is incident radiated power.

A.1.4 Coefficient for test target

The test target is defined by a coefficient of a reflector, which represents the reflectivity of a dirty car without any retro-reflector.

$$CTT = \frac{I_{\text{ref}}}{E_t}$$

where

I_{ref} is radiated intensity in a given direction, out of the reflector, measured in front of the receiver surface, expressed in W/sr;

E_t is intensity of irradiation, out of the transmitter, expressed in W/m²;

CTT is coefficient for test target, expressed in m²/sr.

The reflector (see Figure A.2) with the defined CTT shall have a spatial distribution of the reflection $\geq 8 \times 10^{-3}$ sr.

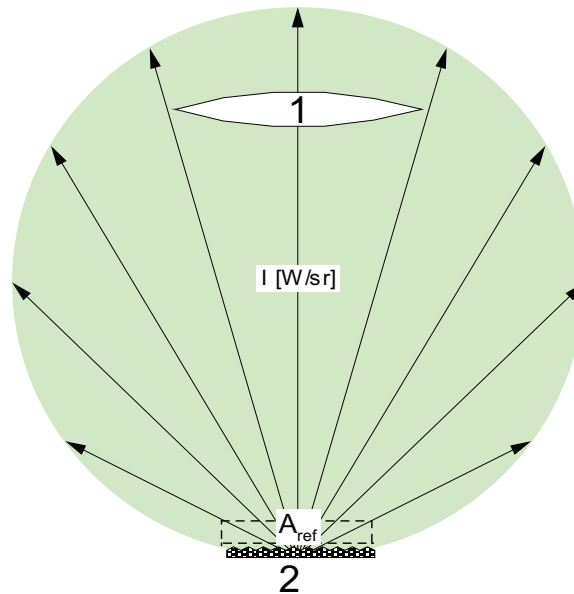
**Key**

- 1 receiver
- 2 reflector

Figure A.2 — Receiver scenario

The *CTT* only describes the quality of a reflector (damping). For the test procedure it is sufficient to have a corner reflector (see Figure A.3) (reduction of the surface to “a point”). However, it is also possible to have a larger surface of reflection if the whole reflectivity of the reflector surface does not exceed the mentioned value.

A.1.5 Reflector size

The size of the reflector (see Figure A.4) shall be defined. Experience shows that a Lambert-reflector with a size of approximately 1,7 m² is the best solution in the case of vehicle representation. A different method could be a “triple” reflector with the size of approximately 20 cm².

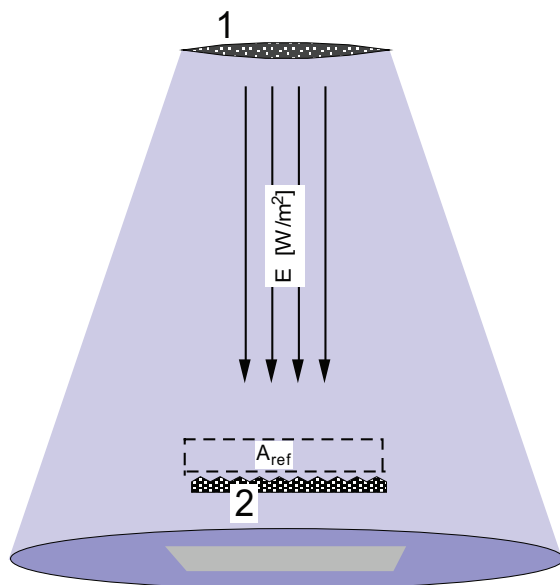

Key

- 1 transmitter
- 2 reflector

Figure A.3 — Transmitter scenario

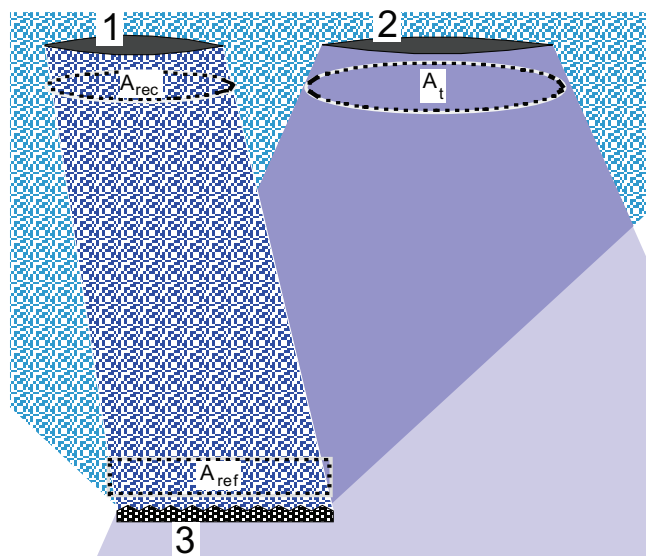

Key

- 1 receiver
- 2 transmitter
- 3 reflector

Figure A.4 — Reflector scenario

The Lambert-reflector reflects the whole energy inside a sphere area (see Figure A.5).

$$\Phi_{\oplus} = \pi \cdot I_0 \cdot \Omega_0$$

where

Φ_{\oplus} is the radiated power, expressed in W;

I_0 is the radiated intensity, expressed in W/sr;

Ω_0 is the solid angle, expressed in sr.

A size of 1,7 m² represents the cross-section of a small vehicle.

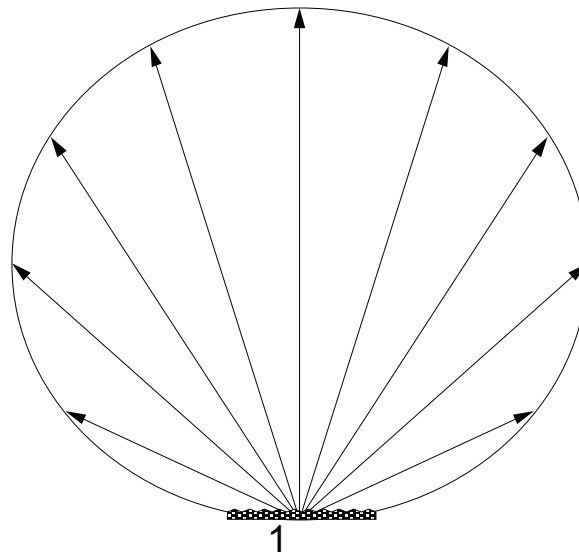

Key

1 reflector

Figure A.5 — Lambert reflector

A.2 Definition of the radar cross section of a corner cube type test target

The test target is defined by a radar cross section, *RCS*.

- $RCS = 10 \pm 3 \text{ m}^2$. At present, for known frequencies (24 GHz, 60 GHz, 77 GHz, 90 GHz), 10 m² represents at least 95 % of all vehicles driving on motorways. For significantly different frequency ranges, investigations shall be carried out.
- Aspect of test target should be as shown in Figure A.6.

— RCS is calculated using the equation

$$RCS = (4 \times \pi \times L^4) / (3 \times \lambda^2)$$

where

λ is the wavelength;

L is the length of a side of a radar test reflector.

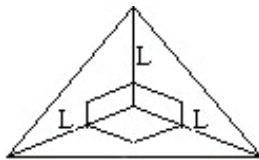

Key

L length of side of radar test reflector

Figure A.6 — Corner cube reflector

Bibliography

- [1] ISO 15622, *Transport information and control systems — Adaptive Cruise Control Systems — Performance requirements and test procedures*
- [2] MITSCHKE, M., WALLENTOWITZ, H. and SCHWARTZ, E. Vermeiden querdynamisch kritischer Fahrzustände durch Fahrzustandsüberwachung (“Avoidance of critical driving states in case of lateral acceleration by using driving state supervision”). *VDI Bericht 91/1991*
- [3] United Nations Economic Commission for Europe, Regulation No. 13-H (ECE-R 13-H), Uniform provisions concerning the approval of passenger cars with regard to braking (see <http://www.unece.org/trans/main/wp29/wp29regs1-20.html>)

www.iso.org

ICS 43.040.15

Price based on 27 pages