

---

---

**Personal equipment for protection  
against falls — Descending devices**

*Équipement personnel de protection contre les chutes — Dispositifs de  
descente*



**PDF disclaimer**

This PDF file may contain embedded typefaces. In accordance with Adobe's licensing policy, this file may be printed or viewed but shall not be edited unless the typefaces which are embedded are licensed to and installed on the computer performing the editing. In downloading this file, parties accept therein the responsibility of not infringing Adobe's licensing policy. The ISO Central Secretariat accepts no liability in this area.

Adobe is a trademark of Adobe Systems Incorporated.

Details of the software products used to create this PDF file can be found in the General Info relative to the file; the PDF-creation parameters were optimized for printing. Every care has been taken to ensure that the file is suitable for use by ISO member bodies. In the unlikely event that a problem relating to it is found, please inform the Central Secretariat at the address given below.



**COPYRIGHT PROTECTED DOCUMENT**

© ISO 2007

All rights reserved. Unless otherwise specified, no part of this publication may be reproduced or utilized in any form or by any means, electronic or mechanical, including photocopying and microfilm, without permission in writing from either ISO at the address below or ISO's member body in the country of the requester.

ISO copyright office  
Case postale 56 • CH-1211 Geneva 20  
Tel. + 41 22 749 01 11  
Fax + 41 22 749 09 47  
E-mail [copyright@iso.org](mailto:copyright@iso.org)  
Web [www.iso.org](http://www.iso.org)

Published in Switzerland

# Contents

Page

Foreword.....	iv
Introduction .....	v
<b>1 Scope .....</b>	<b>1</b>
<b>2 Normative references .....</b>	<b>1</b>
<b>3 Terms, definitions and classifications.....</b>	<b>1</b>
<b>3.1 Terms and definitions.....</b>	<b>1</b>
<b>3.2 Classifications.....</b>	<b>3</b>
<b>4 Requirements .....</b>	<b>8</b>
<b>4.1 General.....</b>	<b>8</b>
<b>4.2 Descent lines: basic requirements .....</b>	<b>8</b>
<b>4.3 Descent line stopper.....</b>	<b>9</b>
<b>4.4 Descent line residual static strength.....</b>	<b>10</b>
<b>4.5 Rated loads.....</b>	<b>10</b>
<b>4.6 Holding load .....</b>	<b>11</b>
<b>4.7 Static strength.....</b>	<b>11</b>
<b>4.8 Dynamic performance .....</b>	<b>12</b>
<b>4.9 Descent energy .....</b>	<b>12</b>
<b>4.10 Descent velocity.....</b>	<b>13</b>
<b>4.11 Temperature rise.....</b>	<b>13</b>
<b>4.12 Special requirements for descending devices class D.....</b>	<b>14</b>
<b>4.13 Function .....</b>	<b>14</b>
<b>4.14 Corrosion resistance.....</b>	<b>14</b>
<b>4.15 Conditioning.....</b>	<b>15</b>
<b>4.16 Marking and information.....</b>	<b>15</b>
<b>5 Test methods.....</b>	<b>15</b>
<b>5.1 Test apparatus .....</b>	<b>15</b>
<b>5.2 General.....</b>	<b>17</b>
<b>5.3 Conditioning.....</b>	<b>18</b>
<b>5.4 Examination of design.....</b>	<b>18</b>
<b>5.5 Static tests.....</b>	<b>19</b>
<b>5.6 Dynamic performance .....</b>	<b>24</b>
<b>5.7 Descent energy, descent velocity, temperature rise.....</b>	<b>31</b>
<b>5.8 Function tests .....</b>	<b>34</b>
<b>5.9 Corrosion resistance.....</b>	<b>41</b>
<b>6 Marking .....</b>	<b>41</b>
<b>7 Information supplied by the manufacturer .....</b>	<b>42</b>
<b>7.1 General.....</b>	<b>42</b>
<b>7.2 Instructions for use .....</b>	<b>42</b>
<b>7.3 Instructions for maintenance .....</b>	<b>45</b>
<b>7.4 Instructions for periodic detailed inspections.....</b>	<b>45</b>
<b>7.5 Instructions for repair.....</b>	<b>46</b>
<b>7.6 Records.....</b>	<b>46</b>
<b>Annex A (informative) Packaging .....</b>	<b>47</b>
<b>Annex B (informative) Functional recommendations for the use of descending devices in the workplace .....</b>	<b>48</b>
<b>Bibliography .....</b>	<b>50</b>

## Foreword

ISO (the International Organization for Standardization) is a worldwide federation of national standards bodies (ISO member bodies). The work of preparing International Standards is normally carried out through ISO technical committees. Each member body interested in a subject for which a technical committee has been established has the right to be represented on that committee. International organizations, governmental and non-governmental, in liaison with ISO, also take part in the work. ISO collaborates closely with the International Electrotechnical Commission (IEC) on all matters of electrotechnical standardization.

International Standards are drafted in accordance with the rules given in the ISO/IEC Directives, Part 2.

The main task of technical committees is to prepare International Standards. Draft International Standards adopted by the technical committees are circulated to the member bodies for voting. Publication as an International Standard requires approval by at least 75 % of the member bodies casting a vote.

Attention is drawn to the possibility that some of the elements of this document may be the subject of patent rights. ISO shall not be held responsible for identifying any or all such patent rights.

ISO 22159 was prepared by Technical Committee ISO/TC 94, *Personal safety — Protective clothing and equipment*, Subcommittee SC 4, *Personal equipment for protection against falls*.

## Introduction

Descending devices conforming to this International Standard are intended to be used in conjunction with an appropriate descent line and other equipment, e.g. an appropriate harness or rescue loop and a reliable anchor, to enable a person to descend from one position to another, either on their own or assisted by another person. Typical uses are emergency egress and work positioning. In addition to their primary function of allowing access to a lower point, descending devices and descent lines have a fall protection function.

Descending devices in this International Standard have been divided into six types. Types 1 and 2 are further divided into four classes.

Type 1 descending devices have an integrated descent line and are intended for multiple evacuations to a safe lower place when users do not need to control their descent speed. The descent speed is automatically controlled, i.e. without the need for intervention by the user.

Type 2 descending devices have an integrated descent line and are manually controlled. They are generally more suitable for single person evacuations to a safe lower place when users may need to control their descent speed and may need to stop somewhere on the descent line.

Types 3 and 4 descending devices are not required to have an integrated descent line. The descent line can be fitted to the descending device on site. These types of descending device are equipped with a manually operated descent control device which, when it is let go, will automatically lock to the descent line and stop the descent (hands-free locking element). In addition, type 3 descending devices will “fail to the locked position” and the descent will stop if the descent control device is moved beyond its descent control parameters, e.g. in a panic situation when the user squeezes the descent control device too far (panic locking element).

Types 5 and 6 descending devices do not have a hands-free automatic locking element or a panic locking element. These descending devices rely on the user to stop the descent manually and to lock off manually, too, typically by wrapping the descent line around the descending device to create enough friction to stop movement. These types are also not required to have an integrated descent line: the descent line can be fitted to the descending device on site.

Descending devices types 1 and 2, which are typically intended primarily for emergency egress, have been classified further by performance. A value, called descent energy, is calculated based on the product of the mass of the user, the maximum descent height for the descending device and the number of descents for which the descending device is designed. In practice, descending devices are subjected to different loads, e.g. a descending device for descending 100 passengers from a cable car at a height of 100 m needs to conform to more stringent requirements than a descending device used by a crane driver to descend from a height of 20 m. The descent energy provides an indication of the appropriateness of a descending device and its descent line for a given application. The descent energy may be used to calculate the maximum combination of descent height and number of descents for a particular use. The classes are A, B, C and D, which are explained in more detail within this International Standard.

Type 2 class D descending devices deserve special mention because they are intended for a specific purpose, i.e. for single use emergency egress only, by trained and competent personnel who, as part of their training, have experienced a descent using this type of descending device.

Descent lines are a necessary component in a descending system and need to meet some basic requirements to ensure that they are suitable for use with relevant descending devices. This International Standard therefore includes such basic requirements for descent lines.

This International Standard recognizes that a descending device could not only travel with the user (normal in rope access, for example) but could also in some circumstances be designed to operate from a fixed position (e.g. at the top of the descent). The test methods reflect this. Operating from a fixed position is normal for type 1 descending devices. It is perhaps not so normal for other types, but is possible.

## ISO 22159:2007(E)

This International Standard presumes that the manufacturer of the descending device, subsystems or components will, for the sake of consistency and traceability, operate a quality management system which will comply with national and regional regulations in force at the time. Guidance on the form this quality management system may take can be found in ISO 9001.

It is highly advisable that manufacturers claiming conformity of their descending devices with this International Standard have their claims verified by an independent, nationally recognized test organisation.

Note the points below.

- It is essential that users of all types of descending devices and their descent lines are trained and assessed as competent before using them unsupervised. This applies even to the totally automatic descending devices of type 1. It applies particularly to types 5 and 6 descending devices, where any mismanagement could have disastrous results. It is advisable that training be ongoing and not just a one-off at the first introduction to the equipment.
- This International Standard does not encompass all foreseeable uses of descending devices or requirements for all possible descending devices. Manufacturers, specifiers and end users can identify uses for which descending devices that are outside the scope of this International Standard are appropriate.
- The requirements specified are generally minimum requirements.

Annex A provides advice on the packaging of descending devices and Annex B gives functional recommendations for the use of descending devices in the workplace.

# Personal equipment for protection against falls — Descending devices

## 1 Scope

This International Standard specifies requirements, test methods, marking and information to be supplied by the manufacturer for descending devices. It also specifies some basic requirements for the descent lines to be used with the descending devices.

This International Standard is applicable to automatic and manually operated descending devices intended for use in the workplace in access, egress, work positioning and rescue systems. Various types and classes of descending devices are defined according to function and performance. These descending devices can be used in situations other than the workplace if adequate training and/or supervision are provided.

This International Standard is not intended to apply to descending devices used in leisure activities such as recreational climbing and caving, although its requirements can be useful in specifying such equipment.

NOTE Descending devices conforming to this International Standard can be designed for use by one or two persons simultaneously.

## 2 Normative references

The following referenced documents are indispensable for the application of this document. For dated references, only the edition cited applies. For undated references, the latest edition of the referenced document (including any amendments) applies.

ISO 9227, *Corrosion tests in artificial atmospheres — Salt spray tests*

ISO/IEC 17025, *General requirements for the competence of testing and calibration laboratories*

## 3 Terms, definitions and classifications

### 3.1 Terms and definitions

For the purposes of this document, the following terms and definitions apply.

#### 3.1.1

##### **anchor point**

secure place of attachment to which the descent line or descending device is connected

#### 3.1.2

##### **attachment element**

primary point of connection to the descending device, as specified by the manufacturer

#### 3.1.3

##### **automatic descending device**

device that enables a person or persons to descend at a controlled rate without any intervention once the descent has commenced

NOTE Automatic descending devices are also known as controlled descent devices.

**3.1.4**

**competent person for periodic detailed inspection**

person who knows the current periodic detailed inspection requirements, recommendations and instructions issued by the manufacturer applicable to the descending device, subsystem or system, and who has the authority, skills and resources to initiate corrective action

**3.1.5**

**competent person for repair**

person authorized by the manufacturer to repair the descending device, subsystem or system

**3.1.6**

**descending device**

automatic or manually operated device used in conjunction with an appropriate descent line, which allows the user, either individually or assisted by another person, to achieve a descent with a controllable velocity

NOTE A descending device can be used for self-descent, self-rescue, rescue by a second person or for rescue by a rescuer and rescuee in a tandem descent.

**3.1.7**

**descent control element**

integral element of the descending device, normally operated by hand, used to control the velocity of descent down the descent line

**3.1.8**

**descent energy**

$W$   
energy measured in joules which results from the product of descent height, descent load and number of descents

**3.1.9**

**descent line**

flexible line for descending, used in conjunction with a descending device

**3.1.10**

**emergency egress**

evacuation from a location in the event of an emergency

**3.1.11**

**hands-free locking element**

integral part or function of the descent control element which stops the descent and thereby prevents an uncontrolled descent or a fall if the user fails to engage the device

NOTE Some creep of the descending device along the descent line can occur (see 4.6).

**3.1.12**

**integrated descent line**

descent line assembled by the manufacturer with a compatible descending device such that the descent line can only be removed by the use of a tool, and in such a way that removal would be clearly evident

**3.1.13**

**manually operated descending device**

descending device that allows a person or persons to descend at a rate that is controlled manually

NOTE 1 Some creep of the descending device along the descent line can occur (see 4.6).

NOTE 2 Manually operated descending devices are also known as descent control devices.



**3.1.14****manufacturer**

maker, authorized representative of a maker or an assembler responsible, where relevant, for the design, test and release of the completed component, subsystem or system placed on the market

**3.1.15****maximum rated load**

maximum mass of person(s), including tools and equipment, to be used with the descending device, as specified by the manufacturer

NOTE Maximum rated load is specified in kilograms.

**3.1.16****minimum rated load**

minimum mass of person(s), including tools and equipment, to be used with the descending device, as specified by the manufacturer

NOTE Minimum rated load is specified in kilograms.

**3.1.17****panic locking element**

integral part or function of the descent control element which stops the descent and thereby prevents an uncontrolled descent or a fall if the user panics and operates the descending device beyond its intended descent control parameters

NOTE Some creep of the descending device along the descent line can occur (see 4.6).

**3.2 Classifications****3.2.1 Classification by type**

Descending devices are classified by type, as described below (see Figure 1 for generic examples of the different types of descending device and Figure 2 for their characteristics):

- a) type 1: automatically operated descending device with integrated descent line;
- b) type 2: manually operated descending device with integrated descent line;
- c) type 3: manually operated descending device with mechanically variable friction, hands-free locking and panic locking features;
- d) type 4: manually operated descending device with mechanically variable friction and hands-free locking features;
- e) type 5: manually operated descending device with mechanically variable friction and non-automatic locking;
- f) type 6: manually operated descending device with non-mechanically variable friction and non-automatic locking.

NOTE Descending devices can conform to the requirements of more than one type.

### 3.2.2 Classification by performance

Descending devices of types 1 and 2 are classified by performance, as follows (see 4.9):

- a) class A for a descent energy,  $W$ , up to  $7,5 \times 10^6$  J;
- b) class B for a descent energy,  $W$ , up to  $1,5 \times 10^6$  J;
- c) class C for a descent energy,  $W$ , up to  $0,5 \times 10^6$  J;
- d) class D for one descent only; the descent energy,  $W$ , depends on the maximum descent height and the maximum rated load.

NOTE In practice, descending devices are subjected to different loads, e.g. a descending device for descending 100 passengers from a cable car at a height of 100 m conforms to more stringent requirements than a descending device used by a crane driver to descend from a height of 20 m. The descent energy can be used to calculate the maximum combination of descent height and number of descents for a particular use.

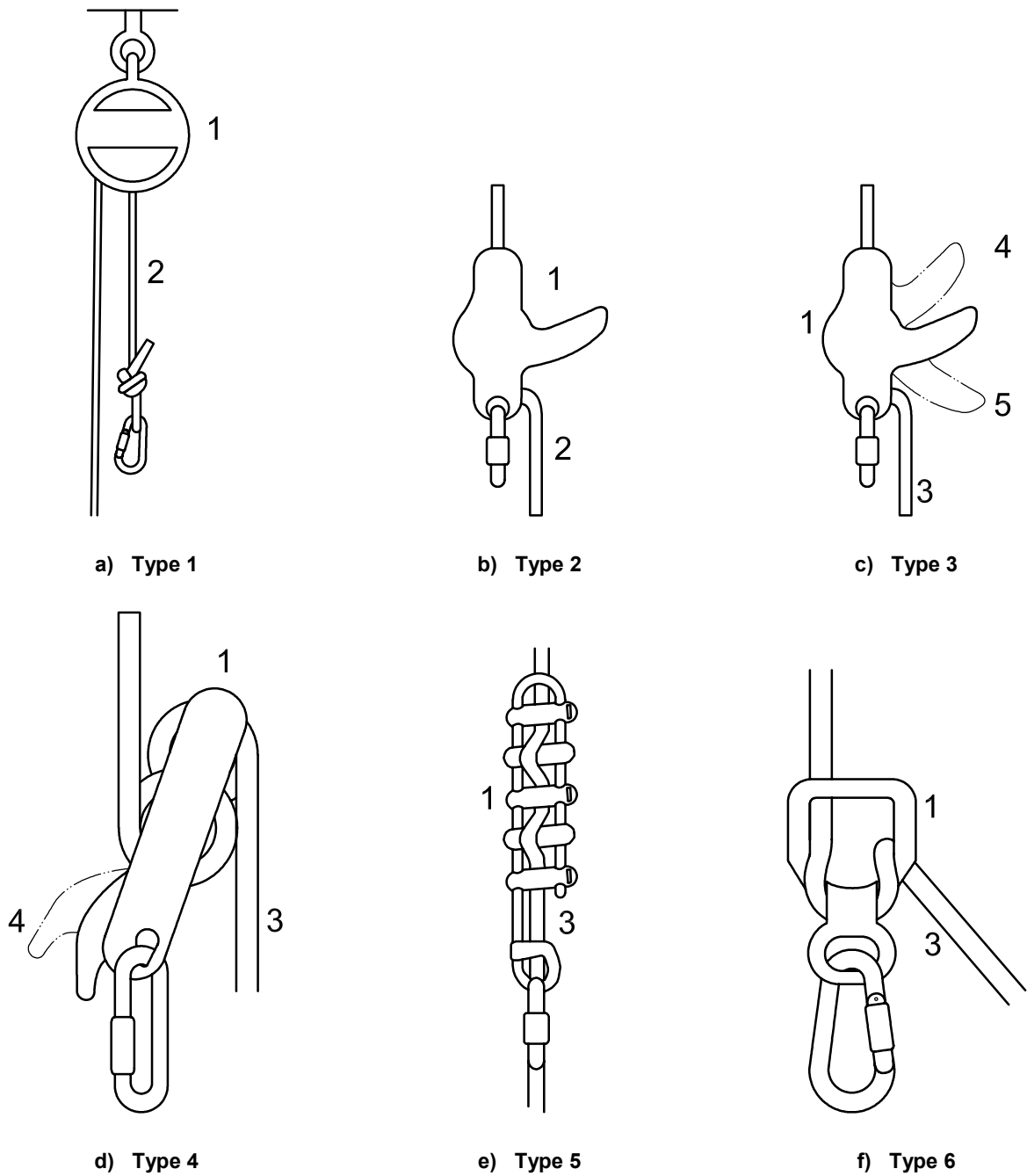

**Key**

- 1 descending device
- 2 integrated descent line
- 3 descent line
- 4 descent control element in hands-free locking position
- 5 descent control element in panic locking position

**Figure 1 — Generic examples of different types of descending device**

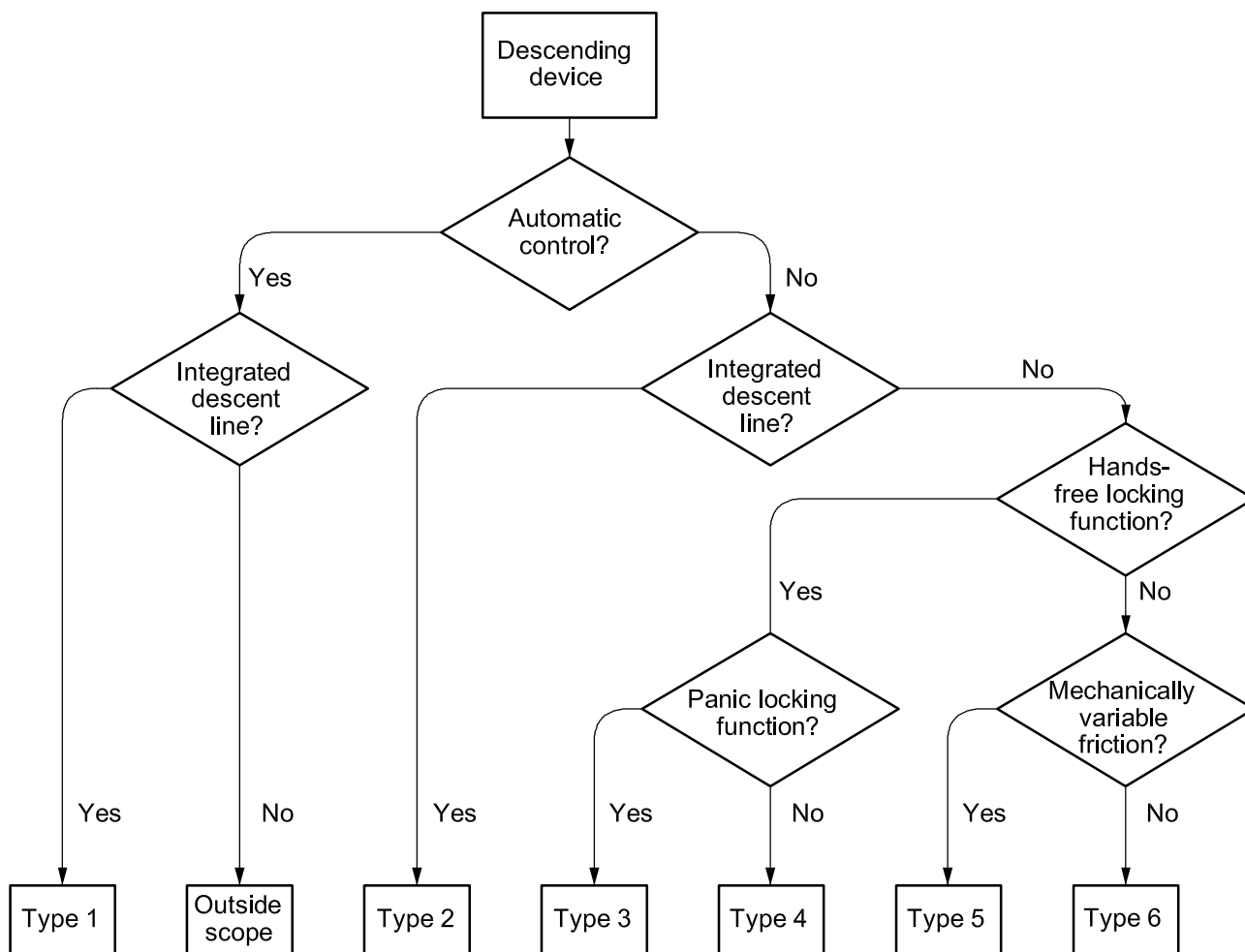

Figure 2 — Characteristics of different types of descending device

Table 1 — Requirements related to descending device type and class

Clause No.	Requirement	Conditioning				Type and class							
		General 4.15.2	Wet 4.15.3	Wet & cold 4.15.4	Very cold 4.15.5	1A, 1B, 1C	1D	2A, 2B, 2C	2D	3	4	5	6
4.1	General requirements	a	a	a	a	b	b	b	b	b	b	b	b
4.2	Descent lines: basic requirements	a	a	a	a	b	b	b	b	b	b	b	b
4.3	Descent line stopper	b	a	a	a	b	b	b	b	a	a	a	a
4.4	Descent line residual static strength	b	a	a	a	b	b	b	b	b	b	b	b
4.5	Rated loads	a	a	a	a	b	b	b	b	b	b	b	b
4.6.1	Holding load: hands-free locking	b	a	a	a	a	a	b	b	b	b	a	a
4.6.2	Holding load: panic locking	b	a	a	a	a	a	b	b	b	a	a	a
4.6.3	Holding load: locked	b	a	a	a	a	a	a	a	a	a	b	b
4.7	Static strength	b	a	a	a	b	b	b	b	b	b	b	b
4.8	Dynamic performance	b	b	c	c	b	b	b	b	b	b	b	b
4.9	Descent energy	b	a	a	a	b	b	b	b	a	a	a	a
4.10	Descent velocity	b	b	c	c	b	b	b	b	b	b	b	b
4.11	Temperature rise	b	a	a	a	b	b	b	b	b	b	b	b
4.12	Special requirements for class D	a	a	a	a	a	b	a	b	a	a	a	a
4.13	Function	b	b	c	a	b	b	b	b	b	b	b	b
4.14	Corrosion resistance	a	a	a	a	b	b	b	b	b	b	b	b
4.16.1	Marking	a	a	a	a	b	b	b	b	b	b	b	b
4.16.2	Information	a	a	a	a	b	b	b	b	b	b	b	b
<p>NOTE All tests are carried out on the minimum and maximum diameters of descent line of the range marked on the descending device, except the corrosion test and where otherwise stated.</p> <p>a No requirement.  b Requirement.  c Optional.</p>													

## 4 Requirements

NOTE A list giving an overview of the requirements relating to each individual type/class of descending device is given in Table 1.

### 4.1 General

**4.1.1** The material specification of all components, including the descent line recommended for use with the descending device, shall be known to be durable at temperatures in which the descending device may be used.

**4.1.2** Components made of materials that may degrade due to exposure to sunlight or other environmental factors shall be protected against such degradation, either by proper shielding of the components, e.g. by the use of UV inhibitors in textiles, or by other suitable means, e.g. a protective coating.

**4.1.3** Descending devices intended to allow removal of the descent line shall have a mechanism or function to prevent the descent line from being detached unintentionally. The descending device shall have a mechanism or shall function to prevent it being detached from the descent line without at least two consecutive deliberate manual actions.

**4.1.4** Descending devices shall not have sharp or rough edges that may cut, abrade or otherwise damage ropes or webbing or cause injury to the user.

**4.1.5** Types 1 and 2 descending devices shall be tested in combination with any descent line with which they will be placed on the market.

**4.1.6** Types 3, 4, 5 and 6 descending devices for use with descent lines that conform to a recognized and appropriate standard, e.g. EN 1891, CI-1801, AS/NZS 4142.3, as specified in the information supplied by the manufacturer of the descending device, shall be tested with the minimum and maximum diameters of descent line for the range marked on the descending device for each standard claimed by the manufacturer. The exception shall be where a particular test method specifies that the test shall be carried out only at either a minimum or a maximum diameter.

**4.1.7** Types 3, 4, 5 and 6 descending devices that do not specify a recognized and appropriate standard to which the descent line shall conform shall be tested on the minimum and maximum diameters of descent line marked on the descending device of every model of the type of descent line which the manufacturer of the descending device claims is appropriate for use with the descending device. The exception shall be where a particular test method specifies that the test shall be carried out only at either a minimum or a maximum diameter.

**4.1.8** Metals which could react together galvanically in normal use to the detriment of the descending device or descent line shall not be used in descending devices and descent lines.

**4.1.9** Connectors supplied with descending devices shall conform to an appropriate standard, e.g. ISO 10333-5, EN 362, CAN/CSA Z259.12, and shall have a manual or an automatic locking gate.

### 4.2 Descent lines: basic requirements

#### 4.2.1 General

**4.2.1.1** Descent lines shall be made from textile rope or webbing or from steel wire rope or any other appropriate material.

**4.2.1.2** Descent lines shall be capable of visual inspection or else subjected to manufacturers' guidance for appropriate examination to confirm that the descent line is satisfactory for continued use.

## 4.2.2 Textile descent lines

**4.2.2.1** Descent lines made from textiles shall be made from virgin filament or multi-filament synthetic fibres suitable for the use intended. The breaking tenacity of the synthetic fibre shall be known to be at least 0,6 N/tex.

**4.2.2.2** The materials used for the construction of textile descent lines shall be known to have a melting point of more than 195 °C. Ropes or webbing made from polypropylene or polyethylene shall not be used for descent lines.

**4.2.2.3** Descent lines made from textiles supplied with, or recommended for use with, types 3, 4, 5 and 6 descending devices shall have a minimum static strength of 18 kN. If the minimum static strength of the textile descent line is not specified by the manufacturer, it shall be tested in accordance with 5.5.4.

**4.2.2.4** When tested in accordance with 5.5.6, descent lines containing aramid fibres shall not break when the test in 5.5.6.6 is carried out with forces equivalent to those specified in 4.7.

**4.2.2.5** When descent lines made from textiles are supplied with permanent end terminations, the eyes formed shall be protected from wear.

## 4.2.3 Wire rope descent lines

**4.2.3.1** Wire rope descent lines made from steel shall be known not to work-harden unduly under foreseeable conditions of use and shall have an appropriate degree of protection against corrosion for such conditions of use. They shall be made from one piece (i.e. no joins in the rope).

NOTE It is advisable that manufacturers of descending devices be particularly careful when selecting or recommending descent lines made from stainless steel as some types of stainless steel can have unpredictable fatigue and corrosion characteristics.

**4.2.3.2** Descent lines made from wire rope supplied with, or recommended for use with, types 3, 4, 5 and 6 descending devices shall be known to have a minimum static strength of 15 kN.

**4.2.3.3** When tested in accordance with 5.5.6, descent lines made from stainless steel wire shall not break when the test in 5.5.6.6 is carried out with forces equivalent to those specified in 4.7.

**4.2.3.4** Wire rope descent lines shall be supplied with permanent end terminations. Eyes formed on wire rope or webbing descent lines shall incorporate a thimble and a termination that has a rated strength of at least 90 % of the descent line nominal strength.

## 4.3 Descent line stopper

For types 1 and 2 descending devices (i.e. descending devices with integrated descent lines), the free or tail end of the descent line shall be protected against slipping through the descending device. Stopper knots (see Figure 3 and 5.5.3.1 b) or clamps with or without stopper devices (see Figure 4 and 5.5.3.1 b) used as protection on textile descent lines shall be made at a distance of at least 0,5 m from the end of the descent line.

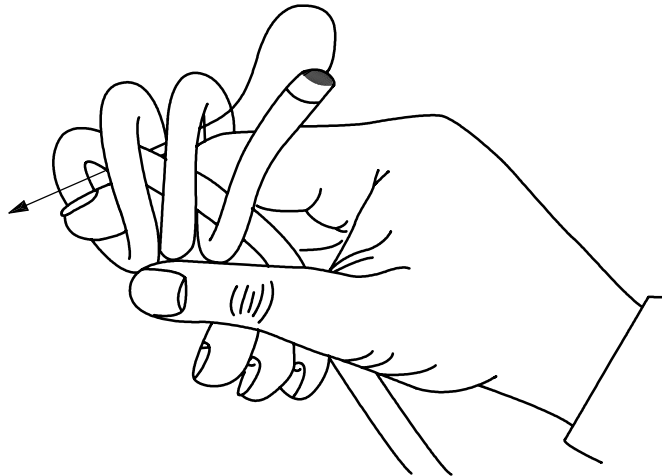
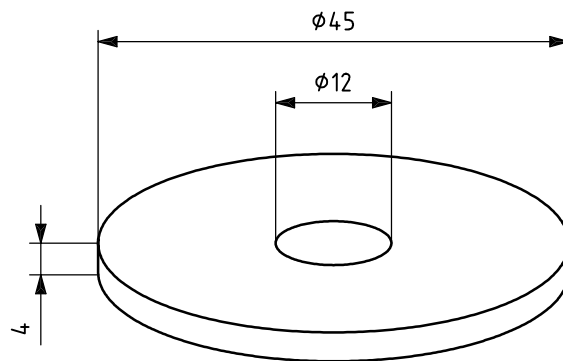

Figure 3 — Stopper knot

Dimensions in millimetres



NOTE The dimensions indicated are examples only.

Figure 4 — Example of stopper device

#### 4.4 Descent line residual static strength

The descent line shall meet the static strength requirement given in 4.7 when tested in accordance with 5.5.5 after the following tests have been carried out:

- a) types 1 and 2 descending devices: the tests in accordance with 5.7.2 and 5.8;
- b) types 3, 4, 5 and 6 descending devices: the tests in accordance with 5.7.3.

#### 4.5 Rated loads

##### 4.5.1 Maximum rated load

The maximum rated load shall be specified by the manufacturer and shall be at least 100 kg. For testing purposes, the maximum rated load shall have a tolerance of  $\left( \begin{smallmatrix} +2 \\ 0 \end{smallmatrix} \right) \%$ .



#### 4.5.2 Minimum rated load

The minimum rated load shall be specified by the manufacturer. For testing purposes, the minimum rated load shall have a tolerance of  $\left(\begin{smallmatrix} +2 \\ 0 \end{smallmatrix}\right)\%$ .

### 4.6 Holding load

#### 4.6.1 Hands-free locking position: types 2, 3 and 4 descending devices

When type 2 descending devices incorporating a hands-free locking element and types 3 and 4 descending devices are tested in accordance with 5.5.2 with a force of  $\left(3 \begin{smallmatrix} +0,1 \\ 0 \end{smallmatrix}\right)$  kN or a force equivalent to 1,5 times the maximum rated load, whichever is the greater, to a tolerance of  $\left(\begin{smallmatrix} +0,1 \\ 0 \end{smallmatrix}\right)$  kN, the descending device shall sustain the load for  $\left(3 \begin{smallmatrix} +0,5 \\ 0 \end{smallmatrix}\right)$  min with a maximum of 300 mm slippage of the descent line through the descending device. After this test, the descending device shall still function properly, i.e. it shall be possible to operate the descending device in accordance with the information supplied by the manufacturer.

#### 4.6.2 Panic locking position: types 2 and 3 descending devices

When type 2 descending devices incorporating a panic-locking element and type 3 descending devices are tested in accordance with 5.5.2 with a force of  $\left(450 \begin{smallmatrix} 0 \\ -10 \end{smallmatrix}\right)$  N applied to the panic locking element and with a force applied to the descending device of  $\left(3 \begin{smallmatrix} +0,1 \\ 0 \end{smallmatrix}\right)$  kN or a force equivalent to 1,5 times the maximum rated load, whichever is the greater, to a tolerance of  $\left(\begin{smallmatrix} +0,1 \\ 0 \end{smallmatrix}\right)$  kN, the descending device shall sustain the load for  $\left(3 \begin{smallmatrix} +0,5 \\ 0 \end{smallmatrix}\right)$  min with a maximum of 300 mm slippage of the descent line through the descending device. After this test, the descending device shall still function properly, i.e. it shall be possible to operate the descending device in accordance with the information supplied by the manufacturer.

#### 4.6.3 Types 5 and 6 descending devices

When types 5 and 6 descending devices are tested in accordance with 5.5.2 with a force of  $\left(3 \begin{smallmatrix} +0,1 \\ 0 \end{smallmatrix}\right)$  kN or a force equivalent to 1,5 times the maximum rated load, whichever is the greater, to a tolerance of  $\left(\begin{smallmatrix} +0,1 \\ 0 \end{smallmatrix}\right)$  kN, the descending device shall sustain the load for  $\left(3 \begin{smallmatrix} +0,5 \\ 0 \end{smallmatrix}\right)$  min with a maximum of 300 mm slippage of the descent line through the descending device. After this test, the descending device shall still function properly, i.e. it shall be possible to operate the descending device in accordance with the information supplied by the manufacturer.

### 4.7 Static strength

#### 4.7.1 All types and classes of descending device except class D

**4.7.1.1** When tested in accordance with 5.5.3, descending devices with a maximum rated load of not more than 100 kg shall withstand a force of  $\left(12 \begin{smallmatrix} +0,5 \\ 0 \end{smallmatrix}\right)$  kN applied at each attachment element of the descending device for 3 min and shall not release the load.

**4.7.1.2** For each 10 kg or part of 10 kg increase in the maximum rated load above 100 kg, descending devices shall withstand an increase in force of 0,3 kN (see Table 2 for examples). The tolerance shall remain the same as that for a maximum rated load of 100 kg.

**Table 2 — Examples of static test forces applicable to different maximum rated loads for all types and classes of descending device except class D**

Maximum rated load kg	Static test force kN
100	12,0
110	12,3
120	12,6
130	12,9
140	13,2
150	13,5
160	13,8
170	14,1
180	14,4
190	14,7
200	15,0

**4.7.2 Descending devices class D**

When tested in accordance with 5.5.3, descending devices of Class D shall withstand a force applied at each attachment element for 3 min equal to at least twice the maximum dynamic force recorded in the dynamic performance tests of 5.6 and shall not release the load.

**4.8 Dynamic performance**

When tested in accordance with 5.6 with a mass equivalent to the maximum rated load, descending devices shall not release the mass and, with the exception of type 1 descending devices, shall not exceed an arrest distance of 2,0 m. No part of the descending device shall show any signs of permanent deformation that could affect its function and the descent line shall not show any signs of tearing or breaking. Minor glazing of the descent line may occur. For class D descending devices, the maximum impact force in each dynamic performance test shall be measured and recorded.

**4.9 Descent energy**

**4.9.1** Descent energy, *W*, expressed in J, is calculated by the following equation:

$$W = m \times g \times h \times n$$

where

- m* is the maximum rated load expressed in kg;
- g* is gravity, 9,81 m/s<sup>2</sup>;
- h* is the descent height, expressed in m;
- n* is the number of descents.

When tested in accordance with 5.7.2 (with testing in succession), types 1 and 2 descending devices and the descent line shall resist the descent energy determined for their class without any impairment of safety, as follows:

- a) for descending devices class A,  $W \geq 7,5 \times 10^6$  J;
- b) for descending devices class B,  $W \geq 1,5 \times 10^6$  J;
- c) for descending devices class C,  $W \geq 0,5 \times 10^6$  J;
- d) for descending devices class D,  $W \geq m \times g \times h_{\max}$ , where  $h_{\max}$  is the maximum descent height, expressed in m.

**4.9.2** Throughout the tests of the descent energy, descent velocity and temperature rise in accordance with 5.7, types 1 and 2 descending devices and their descent lines shall function properly, i.e. it shall be possible to operate the descending device in accordance with the information supplied by the manufacturer, without showing any changes affecting their safety.

#### 4.10 Descent velocity

**4.10.1** When tested in accordance with 5.7.3 with a mass equivalent to the maximum rated load, type 1 descending devices shall not allow the test mass to descend at a rate exceeding 2 m/s.

**4.10.2** For types 2, 3, 4, 5 and 6 descending devices, when tested in accordance with 5.7.3 with a mass equivalent to the maximum rated load, it shall be possible to maintain a descent velocity of a maximum of 2 m/s for at least a period of 5 s.

**4.10.3** When tested in accordance with 5.7.3 with a mass equivalent to the minimum rated load, it shall be possible to keep the descent velocity of types 1 and 2 descending devices classes A, B and C above 0,5 m/s. For types 1 and 2 descending devices, class D, and for types 3 to 6 descending devices, it shall be possible to maintain a descent velocity of more than 0,1 m/s.

**NOTE** It is recognized that during certain sections of the descent, or for particular specialized applications, speeds higher than 2 m/s can be justified. However, it is advisable that the descending devices still be capable of being kept to a maximum of 2 m/s.

#### 4.11 Temperature rise

**4.11.1** When tested in accordance with 5.7.4 with a mass equivalent to the maximum rated load, the temperature due to friction shall not rise to a point where it affects the safe function of the descending device and the descent line.

**4.11.2** When tested in accordance with 5.7.4 with a mass equivalent to the maximum rated load, none of the parts of the descending device handled by the user to control the descents shall develop a temperature higher than 48 °C during the descents.

**4.11.3** When tested in accordance with 5.7.4 with a mass equivalent to the maximum rated load, the maximum recorded temperature of any accessible surface during normal use of types 1 and 2 descending devices shall not exceed the relevant temperature specified in Table 4.

**4.11.4** If the maximum recorded temperature of any external or internal surface accessible during normal use of types 3 to 6 descending devices exceeds the relevant temperature specified in Table 4 when the descending device is tested with a mass equivalent to the maximum rated load in accordance with 5.7.4, a warning shall be given in the information supplied by the manufacturer [see 7.2.2 u)].

## 4.12 Special requirements for descending devices class D

4.12.1 Class D descending devices shall indicate clearly when they have been used.

4.12.2 Class D descending devices shall be configured to prevent re-use after one descent without reconfiguration by the manufacturer or the manufacturer's authorized representative.

## 4.13 Function

### 4.13.1 Types 1 and 2 descending devices

4.13.1.1 When tested in accordance with 5.8.1, descending devices shall function in accordance with the information supplied by the manufacturer.

4.13.1.2 When types 1 and 2 descending devices (all classes) are tested in accordance with 5.8.1 with a mass equivalent to the maximum rated load plus 25 %, it shall be possible to maintain a descent velocity of a maximum of 2 m/s. The descent shall be as continuous as possible.

4.13.1.3 When type 2 descending devices (all classes) are tested in accordance with 5.8.1 with a mass equivalent to the maximum rated load plus 25 %, they shall not allow the test mass to descend at a rate exceeding 2 m/s in the hands-off position.

4.13.1.4 When types 1 and 2 descending devices are tested in accordance with 5.8.1 with a mass equivalent to the minimum rated load, it shall be possible to keep the descent velocity of descending devices classes A, B and C above 0,5 m/s. For descending devices class D, shall be possible to maintain a descent velocity of more than 0,1 m/s. The descent shall be as continuous as possible.

### 4.13.2 Types 2, 3, 4, 5 and 6 descending devices

4.13.2.1 When tested in accordance with 5.8.2, types 2, 3, 4, 5 and 6 descending devices that normally travel with the user and that are intended to be controlled manually by the tail of the descent line shall not move down the descent line at a rate of more than 0,1 m/s.

4.13.2.2 When tested in accordance with 5.8.2, types 2, 3, 4, 5 and 6 descending devices that normally travel with the user and that are normally not intended to be controlled manually by the tail of the descent line shall not move down the descent line at a rate of more than 2 m/s.

4.13.2.3 When tested in accordance with 5.8.3, types 2, 3, 4, 5 and 6 descending devices that normally do not travel with the user and that are intended to be controlled manually by the tail of the descent line shall not allow the descent line to move through the descending device at a rate of more than 0,1 m/s.

4.13.2.4 When tested in accordance with 5.8.3, types 2, 3, 4, 5 and 6 descending devices that normally do not travel with the user and that are normally not intended to be controlled manually by the tail of the descent line shall not allow the descent line to move through the descending device at a rate of more than 2 m/s.

## 4.14 Corrosion resistance

When tested in accordance with 5.9 for two periods of 24 h exposure and 1 h drying, metal parts of descending devices shall show no evidence of corrosion which may affect their function. (White scaling and tarnishing is acceptable if the function is not impaired.)

NOTE Even though the descending device is required to be resistant to corrosion when subjected to a neutral salt spray test, this does not necessarily mean that it is suitable for use in a marine environment.

## 4.15 Conditioning

### 4.15.1 Tests applicable to conditioning

**4.15.1.1** General conditioning of the descending device including descent line(s) (see 4.15.2) shall be applicable to all the tests.

**4.15.1.2** Conditioning to wet (see 4.15.3) shall be applicable for the tests relating to the requirements of 4.8, 4.10 and 4.13.

**4.15.1.3** Conditioning to wet and cold (see 4.15.4) shall be applicable for the tests relating to the requirements of 4.8, 4.10 and 4.13 only if the manufacturer claims that the descending devices and their descent lines can be used in such conditions.

**4.15.1.4** Conditioning to very cold (see 4.15.5) shall be applicable for the tests relating to the requirements of 4.8 and 4.10 only if the manufacturer claims that the descending devices and their descent lines can be used in such conditions.

### 4.15.2 General conditioning

Descending devices and their descent lines shall be conditioned in accordance with 5.3.

### 4.15.3 Conditioning to wet

Descending devices and their descent lines shall be conditioned to wet in accordance with 5.3.

### 4.15.4 Conditioning to wet and cold

If the manufacturer claims that the descending device and descent lines can be used in the temperature range between  $-4\text{ }^{\circ}\text{C}$  and  $+2\text{ }^{\circ}\text{C}$ , descending devices and their descent lines shall be conditioned to wet and cold, as specified in 5.3.

### 4.15.5 Conditioning to very cold

If the manufacturer claims that the descending device and descent lines can be used at temperatures lower than  $-4\text{ }^{\circ}\text{C}$ , descending devices and their descent lines shall be conditioned to very cold, as specified in 5.3, to the lowest temperature specified by the manufacturer.

## 4.16 Marking and information

**4.16.1** Marking of the descending device shall be in accordance with Clause 6.

**4.16.2** Information shall be supplied with the descending device in accordance with Clause 7.

## 5 Test methods

### 5.1 Test apparatus

#### 5.1.1 Test structure

**5.1.1.1** The rigid structure shall be constructed so that its natural frequency (of vibration) in the vertical axis at the anchor point is not less than 100 Hz and so that the application of a force of 20 kN on the anchor point does not cause a deflection greater than 1 mm.

**5.1.1.2** The test structure shall provide a rigid anchor point consisting of a ring of  $(20 \pm 1)$  mm bore and  $(15 \pm 1)$  mm diameter cross section, or a rod of the same diameter cross section.

5.1.1.3 The height of the rigid anchor point shall be such that no part of the descending device or of the rigid steel mass shall strike the floor during the test.

5.1.2 Force measurement instrumentation

5.1.2.1 The force measuring instrumentation shall be capable of measuring forces from 1,2 kN to 20 kN with an accuracy of  $\pm 2\%$  and of withstanding a force of 50 kN without damage, and arranged so that measurements are carried out with a continuously active band up to 100 Hz but with a minimum sampling rate of 1 000 Hz.

5.1.2.2 The arrest force measurement system shall have a corner frequency of 100 Hz with frequency response characteristics which fall within the shaded area illustrated in Figure 5.

5.1.2.3 A recorder shall be used to obtain the time trace of the force, either at the actual time (when recording with the auxiliary measuring device) or at a later time, after storage of the information.

5.1.2.4 The calibration of the force measuring apparatus shall be traceable to an approved physical properties laboratory or approved calibration service in accordance with the accuracy required for the test (see ISO/IEC 17025).

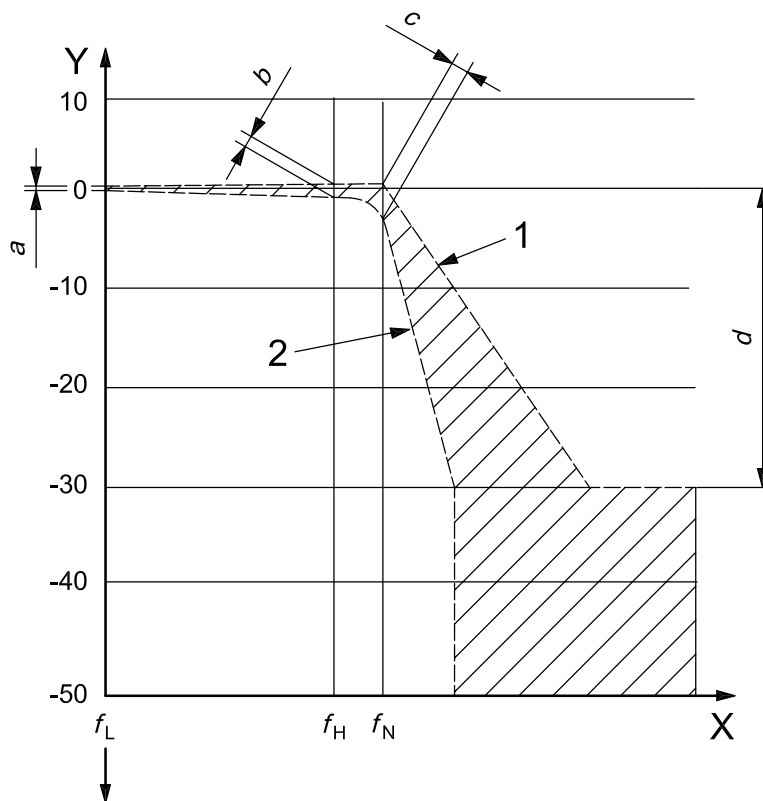

Frequency response values:

- $a = \pm 1/4$  dB
- $b = +1/2$  dB,  $-1$  dB
- $c = +1/2$  dB,  $-3$  dB
- $d = -30$  dB
- $f_L = 0,1$  Hz
- $f_H = 60$  Hz
- $f_N = 100$  Hz

Key

- X  $\log, f$  (Hz)
- Y output/input ratio (dB)
- 1 slope =  $-9$  dB per octave
- 2 slope =  $-24$  dB per octave

Figure 5 — Frequency response characteristics of the force measuring instrumentation

### 5.1.3 Rigid steel mass

The rigid steel mass (see Figure 6) shall be equivalent to the maximum rated load of the descending device (min. 100 kg), except for the tests in 5.7.3.2, when it shall be equivalent to the minimum rated load. The rigid steel mass shall have a maximum width or diameter of 250 mm and shall incorporate a rigid connection point, which shall be central at one end. An optional offset additional connection point is also permissible to accommodate horizontal dimensional constraints of relevant testing procedures and equipment.

Dimensions in millimetres

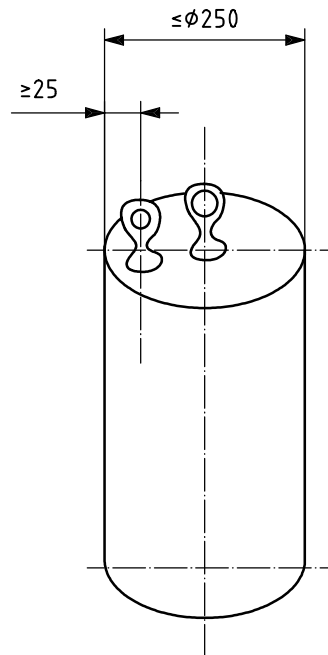

Figure 6 — Rigid steel mass

### 5.1.4 Quick release device

The quick release device shall be compatible with the connection point of the steel masses. It shall ensure the release of a rigid steel mass with no initial velocity.

### 5.1.5 Corrosion resistance test apparatus

The apparatus for the corrosion resistance test (see 5.9) shall be capable of carrying out the neutral salt spray test procedure described in ISO 9227.

## 5.2 General

**5.2.1** For descending devices for use with descent lines that conform to a recognized and appropriate standard (e.g. EN 1891 type A, CI-1801 and AS/NZ 4142.3 for descent lines made from textile rope) as specified in the information supplied by the manufacturer of the descending device, unless a particular clause specifies otherwise, perform all the tests on two descent lines, one to the minimum and one to the maximum diameter as marked on the descending device. If the information supplied by the manufacturer clearly specifies that the descending device is to be used with only one defined descent line, carry out the test with the defined descent line.

**5.2.2** For descending devices for use with descent lines that do not conform to a recognized and appropriate standard, perform all the tests on every model of that type of descent line which the manufacturer of the descending device claims is appropriate for use with the descending device. If the information supplied by the manufacturer clearly specifies that the descending device is to be used with only one defined descent line, carry out the test with the defined descent line.

**5.2.3** If the descending device and the descent line are not supplied as an integrated unit, install the descent line specified by the manufacturer of the descending device in the descending device and attach an appropriate connector to the attachment element in accordance with the information supplied by the manufacturer.

### 5.3 Conditioning

#### 5.3.1 General conditioning

**5.3.1.1** If the information supplied by the manufacturer of the descent line recommends that the descent line be preconditioned before use (e.g. soaked in water), precondition the descent line accordingly.

**5.3.1.2** Condition the descending device and descent line in an atmosphere of  $\left(10 \begin{smallmatrix} 0 \\ -1 \end{smallmatrix}\right)$  % humidity for  $\left(24 \begin{smallmatrix} +1 \\ 0 \end{smallmatrix}\right)$  h. Store at a temperature of  $(20 \pm 2)$  °C and a humidity of  $(65 \pm 5)$  % for at least 72 h. Tests made after general conditioning may be carried out in a relative humidity outside that specified but within the temperature range of  $(23 \pm 5)$  °C. Complete each of these tests within 30 min of removal from the conditioned chamber.

#### 5.3.2 Conditioning to wet

Immerse the descending device and descent line in fresh water for a minimum of 2 h at a temperature of  $(20 \pm 2)$  °C. Remove from the water and allow to drain for  $(15 \pm 1)$  min. Commence the next stage of conditioning or testing, as appropriate, within 2 min of completion of the draining procedure.

#### 5.3.3 Conditioning to wet and cold

If the manufacturer claims that the descending device and descent line can be used in the temperature range between  $-4$  °C and  $+2$  °C, first condition the descending device and descent line to wet in accordance with 5.3.2. After conditioning to wet, wrap the descending device and descent line in an insulating blanket (not specified) and subject them to a temperature of  $\left(-4 \begin{smallmatrix} 0 \\ -2 \end{smallmatrix}\right)$  °C for a minimum of 4 h. Commence each test to be carried out (see 4.8, 4.10 and 4.13) within 2 min of removal from the conditioned atmosphere. The insulating blanket may be removed at the start of the test.

NOTE The insulating blanket is required to enable the descending device and descent line to be within the conditioned temperature range at the time the test is carried out.

#### 5.3.4 Conditioning to very cold

If the manufacturer claims that the descending device and descent line can be used in temperatures less than  $-4$  °C, first condition the descending device and descent line to wet in accordance with 5.3.2. After conditioning to wet, wrap the descending device and descent line in an insulating blanket (not specified) and subject them to the lowest temperature specified by the manufacturer (see 4.15.5) with a tolerance of  $\left(\begin{smallmatrix} 0 \\ -5 \end{smallmatrix}\right)$  °C for a minimum of 4 h. Commence each test to be carried out (see 4.8 and 4.10) within 2 min of removal from the conditioned atmosphere. The insulating blanket may be removed at the start of the test.

NOTE The insulating blanket is required to enable the descending device and descent line to be within the conditioned temperature range at the time the test is carried out.

### 5.4 Examination of design

Confirm by reference to appropriate documentation accompanying the descending device and descent line(s) and by normal or corrected vision and/or tactile examination of the descending device and the descent line(s) that they conform to 4.1, 4.2.1, 4.2.2, 4.2.3, 4.3, 4.12 and 4.16. If it is necessary to examine internal components, dismantle the descending device.



## 5.5 Static tests

### 5.5.1 Rate of stressing for static tests

Use a rate of stressing within the range of  $(150 \pm 10)$  mm/min.

### 5.5.2 Holding load

#### 5.5.2.1 Descending devices that normally travel with the user

**5.5.2.1.1** If the design of the descending device is such that it normally travels with the user during a descent, attach the up-line end of the descent line to the anchor point on the test apparatus (see Figure 7). Position the descending device on the descent line so that the top of it is  $(1000 \pm 50)$  mm down-line from the anchor point of the test apparatus.

Dimensions in millimetres

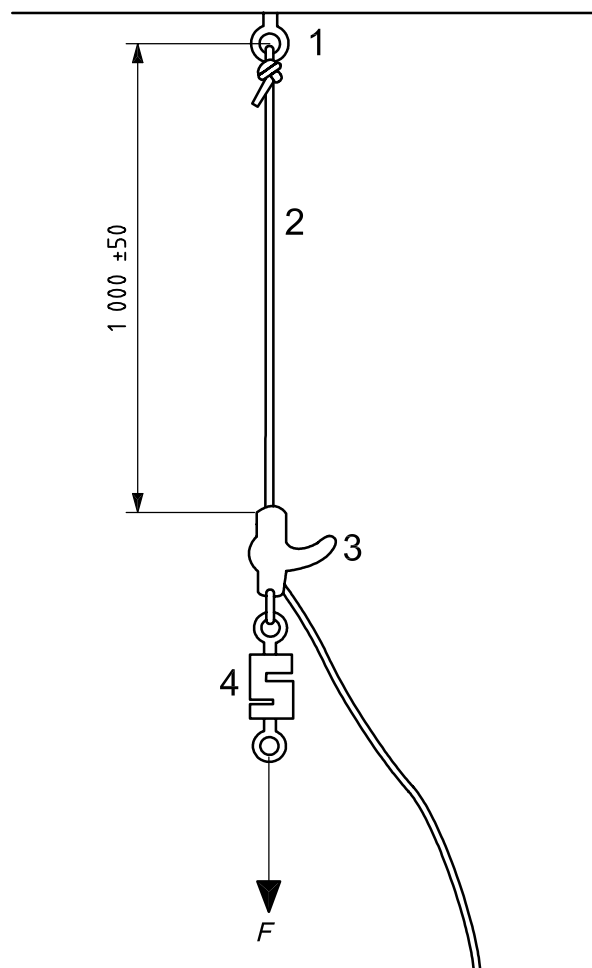

#### Key

- 1 anchor point
- 2 descent line
- 3 descending device
- 4 force measurement device
- $F$  direction of force

**Figure 7 — Holding load test for descending devices that normally travel with the user**

**5.5.2.1.2** If a type 2 descending device is provided with a hands-free locking element or a panic locking element, proceed as for types 3 and 4 descending devices, as appropriate.

**5.5.2.1.3** For types 3 and 4 descending devices, arrange the descent control element in the hands-free engaged position. For types 5 and 6 descending devices and for type 2 descending devices without a hands-free locking element, lock off the descending device in accordance with the information supplied by the manufacturer.

**5.5.2.1.4** Apply to the descending device, via the descending device attachment element, a force equal to that specified in 4.6. Confirm that the requirements of 4.6 are met.

**5.5.2.1.5** For type 3 descending devices, repeat the test, this time with the panic locking element engaged and ensuring that the force specified in 4.6.2 is applied to it. Confirm that the requirements of 4.6 are met.

#### **5.5.2.2 Descending devices that normally do not travel with the user**

**5.5.2.2.1** If the design of the descending device is such that it normally does not travel with the user during a descent, attach the descending device by its attachment element to the anchor point of the test apparatus, using an appropriate connector (see Figure 8). Withdraw  $(1000 \pm 50)$  mm of descent line from the down-line end of the descending device.

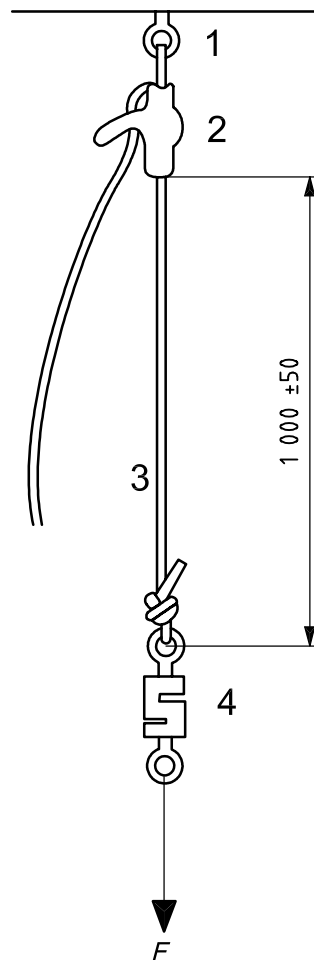
**Key**

- 1 anchor point
- 2 descending device
- 3 descent line
- 4 force measurement device
- F* direction of force

**Figure 8 — Holding load test for descending devices that normally do not travel with the user**

**5.5.2.2.2** If a type 2 descending device is provided with a hands-free locking element or a panic locking element, proceed as for types 3 and 4 descending devices, as appropriate.

**5.5.2.2.3** For types 3 and 4 descending devices, arrange the descent control element in the hands-free engaged position. For types 5 and 6 descending devices and for type 2 descending devices without a hands-free locking element, lock off the descending device in accordance with the information supplied by the manufacturer.

**5.5.2.2.4** Apply a force equal to that specified in 4.6 to the descending device via the terminated down-line end of the descent line [which has been withdrawn from the descending device by  $(1000 \pm 50)$  mm]. Confirm that the requirements of 4.6 are met.

**5.5.2.2.5** For type 3 descending devices, repeat the test, this time with the panic locking element engaged and ensuring that the force specified in 4.6.2 is applied to it. Confirm that the requirements of 4.6 are met.

### 5.5.3 Static strength

**5.5.3.1** Use one of the three test methods described below which is appropriate to the construction of the descending device being tested.

- a) **Method 1** Attach the up-line end of the descent line to the anchor point on the test apparatus. Position the descending device on the descent line so that the top of it is  $(1000 \pm 50)$  mm down-line from the anchor point of the test apparatus. To the same anchor point or to an anchor point that is at the same level as the first anchor point and a maximum distance of 300 mm from it, attach the tail end of the descent line to form a loop in the descent line so that when the specified force is applied, the descending device is pulled against the loop [see Figure 9 a)]. Connect the force measurement device to the attachment element of the descending device.
- b) **Method 2** Attach the up-line end of the descent line to the anchor point on the test apparatus. Position the descending device on the descent line so that the top of it is  $(1000 \pm 50)$  mm down-line from the anchor point of the test apparatus. Make a termination on the descent line below the descending device fitted to it [e.g. by a stopper knot (see Figure 3) or a clamp], to prevent the descending device sliding off the descent line [see Figure 9 b)]. If necessary, an appropriate stopper device may be inserted above the stopper knot or clamp to prevent the termination from entering the descending device (see Figure 4 for an example). Ensure that the design of the stopper device is such that it does not affect the strength of the descending device.
- c) **Method 3** For descending devices where the descent line is contained within the body of the descending device, fully extract the descent line. For the test, terminate the descent line approximately 1 m from the descending device [see Figure 9 c)], using a termination of the same construction as that fitted to the end of the descent line supplied with the descending device. Alternatively, the manufacturer is permitted to supply specimen(s) with the descent line terminated ready for test.

**5.5.3.2** Apply the force specified in 4.7 between the attachment element of the descending device and the test termination(s) of the descent line at the anchor point(s) on the test apparatus. Maintain the force for  $\left(3 \begin{smallmatrix} +0,5 \\ 0 \end{smallmatrix}\right)$  mm and confirm that the requirements of 4.7 are met.

**5.5.3.3** Repeat the test for each attachment element.

**5.5.3.4** For descending devices with an integrated descent line that have been tested to Method 1, take an appropriate length of unused descent line and terminate it at both ends with the same type of terminations as those used in Method 1. The manufacturer is permitted to supply specimen(s) of the descent line terminated ready for test.

Install the terminated length of descent line in a standard static testing machine of appropriate range, using appropriate connectors.

Apply the force specified in 4.7 between the terminations of the descent line. Maintain the force for  $\left(3 \begin{smallmatrix} +0,5 \\ 0 \end{smallmatrix}\right)$  mm and confirm that the requirements of 4.7 are met. The crosshead velocity is specified in 5.5.1.

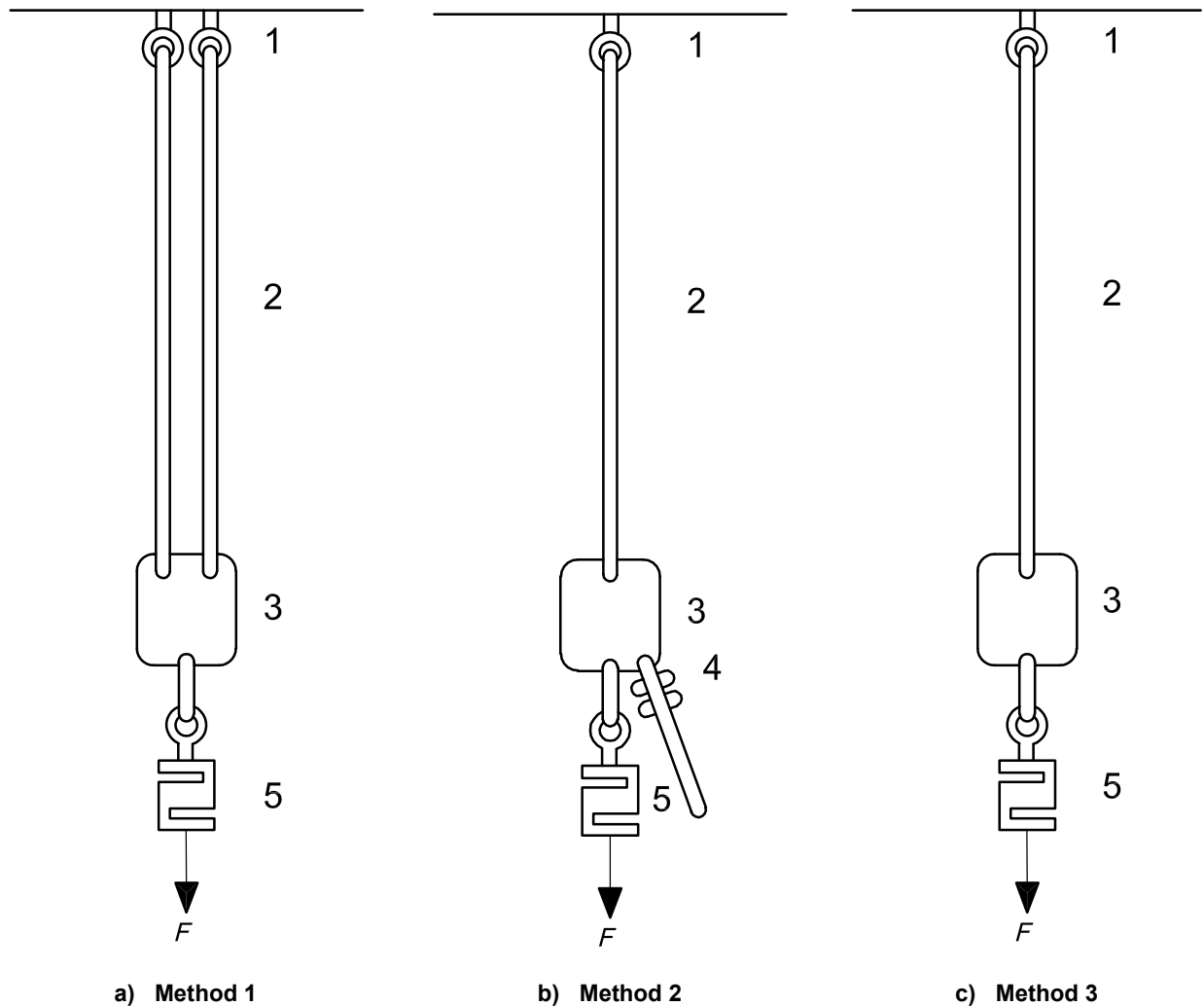

#### Key

- 1 anchor point(s)
- 2 descent line
- 3 descending device
- 4 stopper knot
- 5 force measurement device
- F* direction of force

Figure 9 — Static strength test

#### 5.5.4 Textile descent line strength

Install an appropriate length of the unused textile descent line (the “test piece”) in a standard static testing machine of appropriate range, so that the distance between the clamps or other types of fastening arrangement is  $(1000 +^{100}_0)$  mm. Attach the test piece in such a manner that the fastening arrangement does not affect the results of the test. Test the test piece to break and record the result. The crosshead velocity is specified in 5.5.1. The test is invalid if a break of the test piece is within 100 mm of the fastening arrangement. Confirm that the requirements of 4.2.2.3 are met.

### 5.5.5 Descent line residual static strength

After the tests described in 5.7 (and in the case of types 1 and 2 descending devices, after the tests described in 5.8), take an appropriate length of the descent line from between 5 m and 10 m of its bottom end (the “test piece”) and install it in a standard static testing machine of appropriate range so that the distance between the clamps or other types of fastening arrangement is  $(1000 \text{ }^{+100}_0)$  mm. Attach the test piece in such a manner that the fastening arrangement does not affect the results of the test. Test the test piece to break and record the result. The crosshead velocity is specified in 5.5.1. The test is invalid if a break of the test piece is within 100 mm of the fastening arrangement. Confirm that the requirements of 4.4 are met.

### 5.5.6 Stainless steel wire or aramid textile descent line integrity

**5.5.6.1** Carry out the test with the stainless steel or aramid descent line conditioned in accordance with 4.15.2. Other conditioning is not necessary.

**5.5.6.2** Set up the test in accordance with Figure 13 or Figure 14, depending on the type of descending device being used in the test.

**5.5.6.3** Attach the descending device by its attachment element to a test mass equivalent to the maximum rated load (see 5.1.3) by means of an appropriate connector, and lanyard if necessary. Ensure that the descent line is long enough to allow a pass of the descent line through the descending device of at least 2 m. Suspend the test mass and descending device from the test machine by the descent line through a free-running pulley attached to the test machine at an appropriate height. Connect the free end of the descent line to the descent line pull-through system, e.g. a powered capstan. See Figure 13 for type 1 descending devices and Figure 14 for types 2 to 6 descending devices. Ensure that the direction of travel of the descent line is the same as that in practice, as described in the information supplied by the manufacturer. Test bi-directional descending devices in both directions.

**5.5.6.4** Operate the descent line pull-through system so that the test mass is maintained off the ground within a range between 0 mm and 1000 mm of movement. Carry out the test so that the same section of descent line passes through the descending device by at least 2 m each pass.

**5.5.6.5** Carry out a number of passes equal to the maximum number of descents specified for the descending device by the manufacturer. Carry out the repeat passes with as short an interval as possible between them and in one continuous operation, but account may be taken of what the chronological intervals would be in practice.

**5.5.6.6** Install the 2 m length of descent line used in the passes in a standard static testing machine of appropriate range so that the distance between the clamps or other types of fastening arrangement is  $(1000 \text{ }^{+100}_0)$  mm. Attach the test piece in such a manner that the fastening arrangement does not affect the results of the test. Apply the force specified in 4.7. Maintain the force for a period of  $(3 \text{ }^{+0,5}_0)$  mm and verify that the descent line does not break. The crosshead velocity is specified in 5.5.1. The test is invalid if a break of the test piece is within 100 mm of the fastening arrangement. Confirm that the requirements of 4.2.2.4 and 4.2.3.3 are met.

## 5.6 Dynamic performance

### 5.6.1 Descending devices that normally travel with the user

**5.6.1.1** If the design of the descending device is such that it normally travels with the user during a descent, secure the up-line end of the descent line to the anchor point on the test apparatus (see Figure 10). If the descent line is not supplied with terminations, terminate the descent line by a figure of eight knot as shown in Figure 11. Position the descending device so that the point at which the descent line enters the descending device (up-line) is  $(600 \text{ }^{+30}_0)$  mm vertically down-line from the anchor point of the test apparatus.

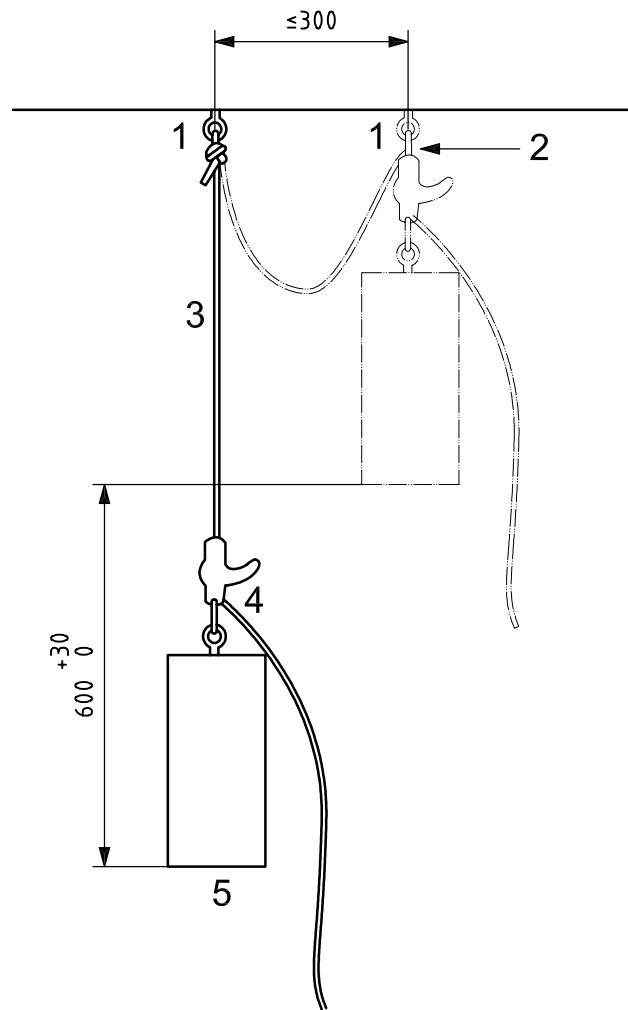

**Key**

- 1 anchor point
- 2 quick release device
- 3 descent line
- 4 descending device
- 5 test mass

**Figure 10 — Dynamic performance test for descending devices that normally travel with the user**

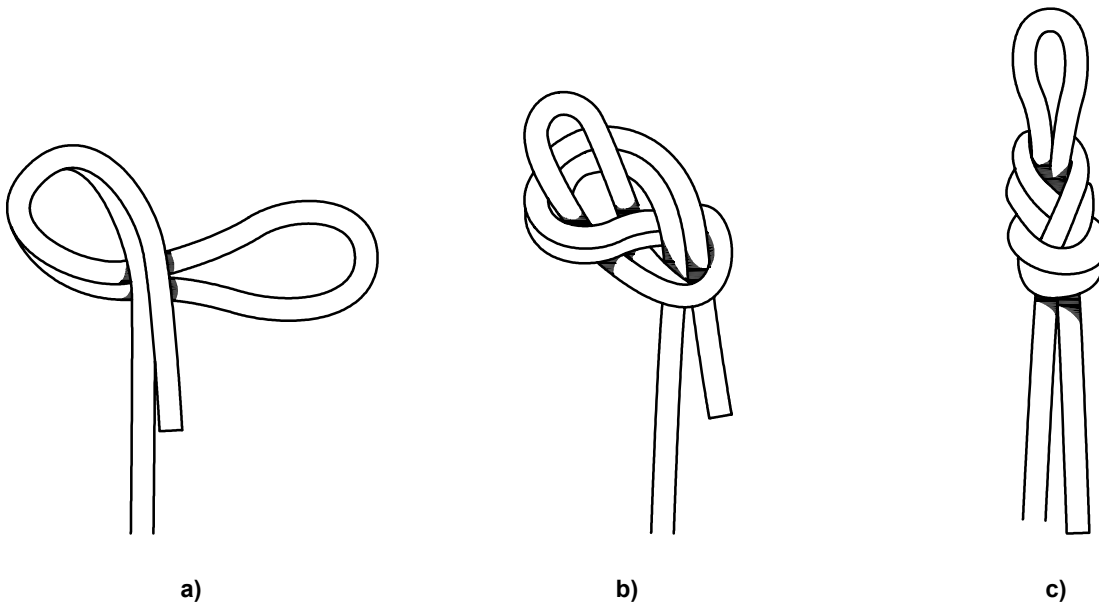

Figure 11 — Method of tying a figure of eight knot

**5.6.1.2** If a type 2 descending device is provided with a hands-free locking element or a panic locking element, proceed as for types 3 and 4 descending devices, as appropriate.

**5.6.1.3** For types 3 and 4 descending devices, arrange the descent control element in the hands-free engaged position. For type 5 descending devices and for type 2 descending devices without a hands-free locking element, where the information supplied by the manufacturer allows users to configure the descent line to provide different frictional resistance through the descending device, configure for the maximum frictional resistance. For type 6 descending devices, lock off the descending device in accordance with the information supplied by the manufacturer.

**5.6.1.4** Allow a minimum clearance distance of 3 m from the test apparatus anchor point to the ground. Attach the test mass specified in 5.1.3 to the attachment element of the descending device using an appropriate connector. Suspend the test mass for  $(60 \pm 5)$  s to pre-tension the descent line. Raise the descending device and the test mass and attach it to the test apparatus by the quick release device specified in 5.1.4 in such a way that the anchor point of the test apparatus is level with the point at which the descent line enters the descending device, i.e. so that there will be a 600 mm minimum free fall. Ensure that the attachment point of the test mass is a maximum horizontal distance of 300 mm from the attachment element of the descending device. Release the test mass without initial velocity. Confirm that the requirements of 4.8 are met.

**5.6.1.5** For type 3 descending devices, repeat the test, this time with the panic locking element engaged. This may necessitate fixing the panic locking element in place. Confirm that the requirements of 4.8 are met.

**5.6.1.6** For types 3 and 4 descending devices, if the manufacturer recommends descent line locking additional to that provided by the hands-free locking and panic locking elements, e.g. by wrapping or knotting the descent line around the descending device, repeat the test with the descending device locked off in accordance with the information supplied by the manufacturer. Confirm that the requirements of 4.8 are met.

**5.6.1.7** For type 5 descending devices, if the manufacturer recommends descent line locking additional to that provided by the maximum friction position, e.g. by wrapping or knotting the descent line around the descending device, repeat the test with the descending device locked off in accordance with the information supplied by the manufacturer. Confirm that the requirements of 4.8 are met.



**5.6.1.8** For class D descending devices, if the information supplied by the manufacturer states that the descending device can be locked off or if there are no specific instructions concerning locking off, carry out each test with the descending device locked off. If the information supplied by the manufacturer states that the class D descending device must not be locked off, carry out each test in the maximum friction position. Carry out each test three times and record the maximum impact force in each case. A new descent line shall be used for each test but the same descending device may be used.

**5.6.1.9** Repeat the tests with the descending device and descent line conditioned to wet (see 4.15.3), unless the tests conforming to 5.6.1.10 or 5.6.1.11 are to be carried out. Confirm that the requirements of 4.8 are met.

**5.6.1.10** If the manufacturer claims that the descending device and descent line can be used in the temperature range between  $-4\text{ }^{\circ}\text{C}$  and  $+2\text{ }^{\circ}\text{C}$ , repeat the tests with the descending device and descent line conditioned to wet and cold (see 4.15.4). Confirm that the requirements of 4.8 are met.

**5.6.1.11** If the manufacturer claims that the descending device and descent lines can be used in temperatures less than  $-4\text{ }^{\circ}\text{C}$ , repeat the tests with the descending device and descent line conditioned to very cold (see 4.15.5). Confirm that the requirements of 4.8 are met.

## **5.6.2 Descending devices that normally do not travel with the user**

**5.6.2.1** If the design of the descending device is such that it normally does not travel with the user during a descent, attach the descending device by its attachment element to the anchor point of the test apparatus, using an appropriate connector (see Figure 12). Allow a minimum clearance distance of 3 m from the test apparatus anchor point to the ground. Attach the test mass specified in 5.1.3 to the terminated down-line end of the descent line and adjust the descent line so that test mass is suspended from the descending device by the descent line with a vertical distance of  $(600^{+30}_0)$  mm vertically down-line between the attachment point on the test mass and the point at which the descent line leaves the descending device. Suspend the test mass for  $(60 \pm 5)$  s.

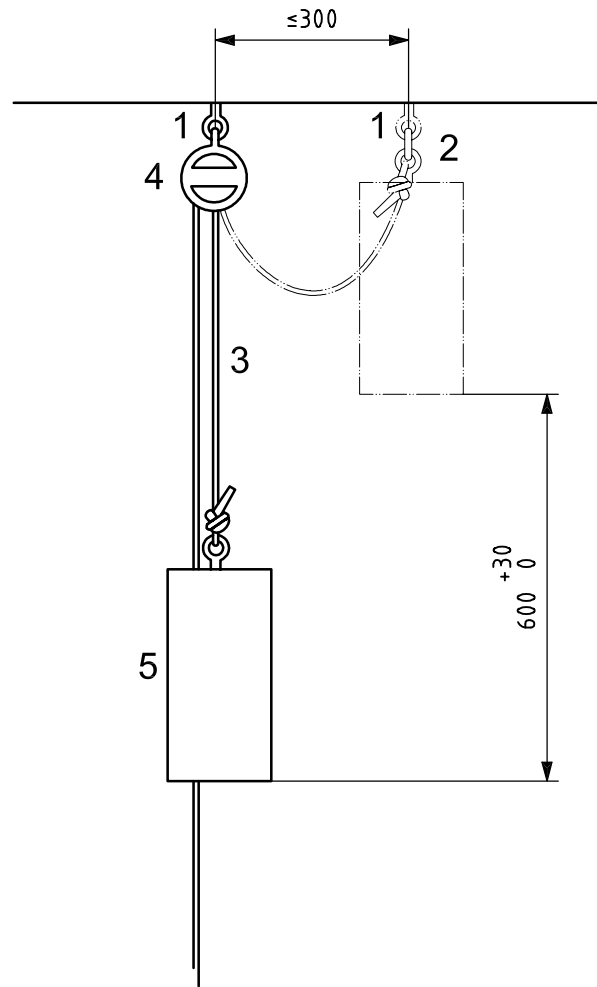

**Key**

- 1 anchor point
- 2 quick release device
- 3 descent line
- 4 descending device
- 5 test mass

**Figure 12 — Dynamic performance test for descending devices that normally do not travel with the user**

**5.6.2.2** If a type 2 descending device is provided with a hands-free locking element or a panic locking element, proceed as for types 3 and 4 descending devices, as appropriate.

**5.6.2.3** For types 3 and 4 descending devices, arrange the descent control element in the hands-free engaged position. For type 5 descending devices and for type 2 descending devices without a hands-free locking element, where the information supplied by the manufacturer allows users to configure the descent line to provide different frictional resistance through the descending device, configure for the maximum frictional resistance. For type 6 descending devices, lock off the descending device in accordance with the information supplied by the manufacturer.

**5.6.2.4** Raise the test mass specified in 5.1.3 and attach it to the test apparatus by the quick release device specified in 5.1.4 in such a way that the attachment point of the test mass is level with the point at

which the descent line exits the descending device, i.e. so that there will be a 600 mm minimum free fall. Ensure that the attachment point of the test mass is a maximum horizontal distance of 300 mm from the attachment element of the descending device. Release the test mass without initial velocity. Confirm that the requirements of 4.8 are met.

**5.6.2.5** For type 3 descending devices, repeat the test, this time with the panic locking element engaged. This may necessitate fixing the panic locking element in place. Confirm that the requirements of 4.8 are met.

**5.6.2.6** For types 3 and 4 descending devices, if the manufacturer recommends descent line locking additional to that provided by the hands-free locking and panic locking elements, e.g. by wrapping or knotting the descent line around the descending device, repeat the test with the descending device locked off in accordance with the information supplied by the manufacturer. Confirm that the requirements of 4.8 are met.

**5.6.2.7** For type 5 descending devices, if the manufacturer recommends descent line locking additional to that provided by the maximum friction position, e.g. by wrapping or knotting the descent line around the descending device, repeat the test with the descending device locked off in accordance with the information supplied by the manufacturer. Confirm that the requirements of 4.8 are met.

**5.6.2.8** For class D descending devices, if the information supplied by the manufacturer states that the descending device can be locked off or if nothing is said about locking off, carry out each test with the descending device locked off. If the information supplied by the manufacturer states that the class D descending device must not be locked off, carry out each test in the maximum friction position. Carry out each test three times and record the maximum impact force in each case. A new descent line shall be used for each test but the same descending device may be used.

**5.6.2.9** Repeat the tests with the descending device and descent line conditioned to wet (see 4.15.3), unless the tests conforming to 5.6.2.10 or 5.6.2.11 are to be carried out. Confirm that the requirements of 4.8 are met.

**5.6.2.10** If the manufacturer claims that the descending device and descent line can be used in the temperature range between  $-4\text{ }^{\circ}\text{C}$  and  $+2\text{ }^{\circ}\text{C}$ , repeat the tests with the descending device and descent line conditioned to wet and cold (see 4.15.4). Confirm that the requirements of 4.8 are met.

**5.6.2.11** If the manufacturer claims that the descending device and descent lines can be used in temperatures less than  $-4\text{ }^{\circ}\text{C}$ , repeat the tests with the descending device and descent line conditioned to very cold (see 4.15.5). Confirm that the requirements of 4.8 are met.

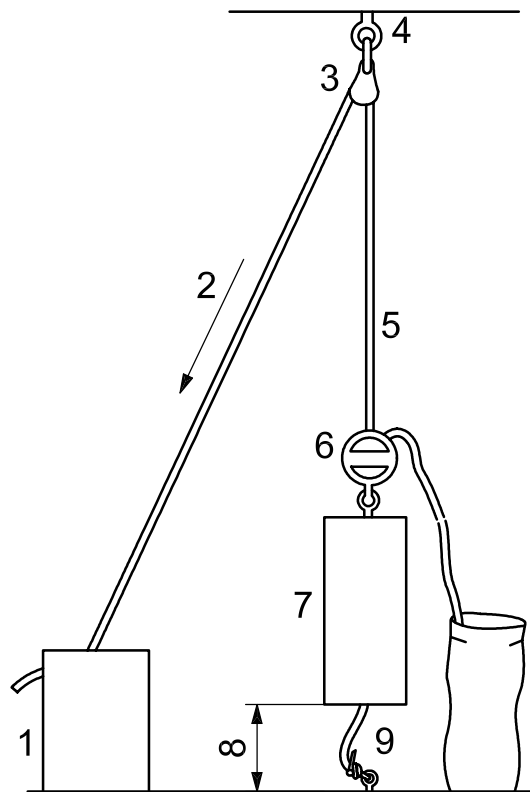

**Key**

- 1 descent line pull-through system, e.g. a powered capstan
- 2 direction of travel of descent line
- 3 free-running pulley
- 4 anchor point
- 5 descent line
- 6 descending device
- 7 test mass
- 8 test mass maintained off the ground within a range between 0 mm and 1 000 mm
- 9 test mass retention lanyard

**Figure 13 — Descent energy, descent velocity and temperature rise test apparatus and set up for type 1 descending devices**

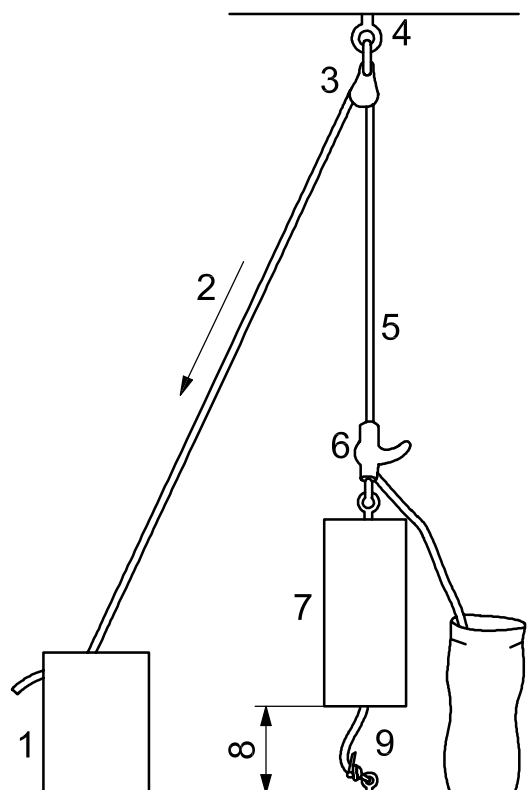

### Key

- 1 descent line pull-through system, e.g. a powered capstan
- 2 direction of travel of descent line
- 3 free-running pulley
- 4 anchor point
- 5 descent line
- 6 descending device
- 7 test mass
- 8 test mass maintained off the ground within a range between 0 mm and 1 000 mm
- 9 test mass retention lanyard

**Figure 14 — Descent energy, descent velocity and temperature rise test apparatus and set up for types 2, 3, 4, 5 and 6 descending devices**

## 5.7 Descent energy, descent velocity, temperature rise

### 5.7.1 Test set-up and operation

#### 5.7.1.1 General

For all types and classes of descending device, tests should be performed in accordance with 5.7.1.2, at a place determined by the test house and the manufacturer to be appropriate for testing, at the maximum descent height as specified in the information supplied by the manufacturer (known as the “field test”). If the maximum descent height is not specified, use a descent line with a length of 100 m. Where it is not practicable to carry out the field test, e.g. where the maximum descent height cannot be achieved, carry out the tests with a mechanical test apparatus, as shown in Figures 13 and 14 and described in 5.7.1.3. The test apparatus, set-up and operation for the descent energy, descent velocity and temperature rise tests are essentially the same. The measurement of descent velocity and temperature may be carried out during one pass of the descent line through the descending device.

**5.7.1.2 Field tests**

**5.7.1.2.1** Carry out the tests using a new descending device and descent line and following the manufacturer's instructions. If the descending device is a bi-directional device, carry out the tests in both directions. Attach the descending device by its attachment element to a test mass by an appropriate connector, and lanyard if necessary. The value of the test mass is given in each test, i.e. 5.7.2, 5.7.3 and 5.7.4.

**5.7.1.2.2** Carry out the descent vertically from the top to the bottom of the descent line, with the descent velocity as constant as possible. Confirm that the requirements of 4.9 (where appropriate), 4.10 and 4.11 are met.

**NOTE** It is highly advisable that if a person carries out the tests by accompanying the descending device during the descent, he/she be protected against a fall in case there is a failure or loss of control of the descending device and/or the descent line.

**5.7.1.3 Tests using a mechanical test apparatus**

**5.7.1.3.1** Carry out the tests using a new descending device and descent line and following the manufacturer's instructions. If the descending device is a bi-directional device, carry out the tests in both directions. Attach the descending device by its attachment element to a test mass by means of an appropriate connector, and lanyard if necessary. The value of the test mass is given in each test, i.e. 5.7.2, 5.7.3 and 5.7.4. Ensure that the descent line is a minimum of 3 m longer than the maximum descent specified in the information supplied by the manufacturer. Suspend the test mass and descending device from the test machine by the descent line through a free-running pulley attached to the test machine at an appropriate height. Connect the free end of the descent line to the descent line pull-through system, e.g. a powered capstan. See Figure 13 for type 1 descending devices and Figure 14 for types 2 to 6 descending devices. Ensure that the direction of travel of the descent line is the same as that in practice, as described in the information supplied by the manufacturer.

**5.7.1.3.2** Operate the descent line pull-through system so that the test mass is maintained off the ground within a range between 0 mm and 1000 mm of movement. Using a suitable method, control and record the speed of the descent line through the descending device at the maximum velocity specified in 4.10 or, if the maximum velocity is less than this, at the maximum velocity, with a tolerance in either case of  $-0,1$  m/s. Carry out the test over a length of the descent line that is at least equal to that of the maximum descent specified for the descending device in the information supplied by the manufacturer (effectively the entire length of the descent line).

**5.7.2 Descent energy**

**5.7.2.1** The descent energy tests are applicable only to types 1 and 2 descending devices. The value of the test mass and the length of the descent are given in Table 3.

**5.7.2.2** Using the test set-up and operation described in 5.7.1, as appropriate, carry out the field test in accordance with 5.7.1.2 or operate the mechanical test apparatus in accordance with 5.7.1.3. Repeat the test for the maximum number of descents specified for the descending device in the information supplied by the manufacturer. Carry out the repeat tests with as short an interval as possible between them and in one continuous operation, but account may be taken of what the chronological intervals would be in practice.

**NOTE** The number of descents varies in accordance with the equation for descent energy (see 4.9).

**Table 3 — Descent energy test**

<b>Class</b>	<b>Height m</b>	<b>Mass kg</b>
A	100	maximum rated load
B	100	maximum rated load
C	20	maximum rated load
D	as specified by the manufacturer	maximum rated load

**5.7.2.3** If descending devices of classes A and B are intended for heights less than 100 m, carry out the descent energy test with a descent line length equivalent to the descent height specified in the information supplied by the manufacturer, plus a minimum of 3 m. Increase the number of descents in order to reach the descent energies specified in 4.9.

**5.7.2.4** Confirm that the requirements of 4.9 are met.

### **5.7.3 Descent velocity**

**5.7.3.1** Using the test set-up and operation described in 5.7.1, as appropriate, carry out the field test in accordance with 5.7.1.2 or operate the mechanical test apparatus in accordance with 5.7.1.3. Carry out the test using a mass equivalent to the maximum rated load. Confirm that the requirements of 4.10.2 and 4.10.3 are met.

**5.7.3.2** Using the same descending device and descent line as that used in 5.7.3.1, but this time using a mass equivalent to the minimum rated load, carry out the field test in accordance with 5.7.1.2 or operate the mechanical test apparatus so that the test mass is maintained off the ground within a range between 0 mm and 1000 mm of movement. Using a suitable method, control and record the speed of the descent line through the descending device. Carry out the test over a length of the descent line that is at least equal to that of the maximum descent specified for the descending device in the information supplied by the manufacturer (effectively the entire length of the descent line). If the maximum descent is not specified, use a descent line with a length of 100 m. Confirm that the requirements of 4.10.4 are met.

**5.7.3.3** Repeat the tests with the descending device and descent line conditioned to wet (see 4.15.3), unless the tests conforming to 5.7.3.4 or 5.7.3.5 are to be carried out. Confirm that the requirements of 4.10.2 and 4.10.3 are met.

**5.7.3.4** If the manufacturer claims that the descending device and descent line can be used in the temperature range between  $-4\text{ }^{\circ}\text{C}$  and  $+2\text{ }^{\circ}\text{C}$ , repeat the tests with the descending device and descent line conditioned to wet and cold (see 4.15.4). Confirm that the requirements of 4.10.2 and 4.10.3 are met.

**5.7.3.5** If the manufacturer claims that the descending device and descent lines can be used in temperatures less than  $-4\text{ }^{\circ}\text{C}$ , repeat the tests with the descending device and descent line conditioned to very cold (see 4.15.5). Confirm that the requirements of 4.10.2 and 4.10.3 are met.

### **5.7.4 Temperature rise**

**5.7.4.1** The temperature tests assume an ambient temperature in the test room of  $(20 \pm 2)\text{ }^{\circ}\text{C}$ . Allow for this and make adjustments accordingly when recording the temperatures after each test (see 5.3.1.2).

**5.7.4.2** Carry out the tests using a descending device and descent line conditioned in accordance with 4.15.2 and with a mass equivalent to the maximum rated load. Using the test set-up and operation described in 5.7.1, as appropriate, carry out the field test in accordance with 5.7.1.2 or operate the mechanical test apparatus in accordance with 5.7.1.3.

**5.7.4.3** Within 20 s after the end of the descent velocity test using a mass equivalent to the maximum rated load, measure the temperature of parts of the descending device handled by the user to control the descent (see 4.11.2).

**5.7.4.4** Within 40 s after the end of the descent velocity test using a mass equivalent to the maximum rated load, measure the temperature of accessible exterior surface parts of the descending device other than those handled by the user to control the descent (see 4.11.3 and 4.11.4).

**5.7.4.5** Within 60 s after the end of the descent velocity test using a mass equivalent to the maximum rated load, measure the temperature of accessible interior surface parts of the descending device other than those handled by the user to control the descent (see 4.11.3 and 4.11.4).

**5.7.4.6** With reference to 5.7.4.1 and Table 4, record the temperatures measured and confirm that the requirements of 4.11 are met.

**Table 4 — Maximum allowed temperature of various parts of the descending device after the velocity test using the maximum rated load**

Material	Parts handled by the user to control the descent °C	Other parts (external and internal) °C
Uncoated metal	48	60 (external), 65 (internal)
Coated metal	48	65
Ceramics, glass and stone	48	66
Plastics	48	69
Wood	48	89

NOTE The information in this table is taken from EN 563:1994. The metal coating referred to in the first column is a special thermal coating (see EN 563). The figures in the second column assume a contact time of around 10 min and the figures in the third column assume a contact time of between 1 s and 10 s.

**5.8 Function tests**

**5.8.1 Types 1 and 2 descending devices**

**5.8.1.1** Carry out the tests after testing to 5.6. Use the same descending device and descent line as those used in 5.6 and follow the manufacturer's instructions. Carry out the tests

- a) at the maximum descent height specified by the manufacturer at an appropriate place agreed between the test house and the manufacturer; if the descending device is a bi-directional device, carry out the test in both directions;
- b) with the descending device and descent line generally conditioned (see 4.15.2);
- c) with the following test loads:
  - 1) a mass equivalent to the maximum rated load plus 25 %;
  - 2)  $(30^{+0,5}_0)$  kg or a mass equivalent to the minimum rated load, whichever is less.

**5.8.1.2** Carry out the descent vertically from the top to the bottom of the descent line, with the descent velocity as constant as possible. For type 2 descending devices, by agreement between the test house and the manufacturer and after confirming by assessment that the results are unlikely to be affected, it is permitted to attach the descending device to the structure rather than to the person in order to avoid a person having to descend during the function test.

NOTE It is highly advisable that, if a person carries out the function test by accompanying the descending device during the descent, he/she be protected against a fall in case there is a failure of the descending device and/or the descent line.

**5.8.1.3** Confirm that the requirements of 4.13.1 are met.

**5.8.1.4** Repeat the test with the descending device and descent line conditioned to wet (see 4.15.3). Confirm that the requirements of 4.13.1 are met.

**5.8.1.5** If the manufacturer claims that the descending device and descent line can be used in the temperature range between -4 °C and +2 °C, repeat the test with the descending device and descent line conditioned to wet and cold (see 4.15.4). Confirm that the requirements of 4.13.1 are met.



## 5.8.2 Types 2, 3, 4, 5 and 6 descending devices that normally travel with the user

### 5.8.2.1 Test set-up

If the design of the descending device is such that it normally travels with the user during a descent, attach the up-line end of the descent line to the anchor point on the test apparatus so that the descent line is suspended vertically (see Figure 15). If the descending device is intended to accept a range of diameters of descent line, use the minimum diameter of descent line as marked on the descending device in accordance with point i) of Clause 6. If the descending device is not already attached to the descent line, attach the descending device to the descent line in accordance with the information supplied by the manufacturer. Restrain the descending device so that it cannot move along the descent line until the test commences. Attach a mass equivalent to the maximum rated load to the descending device via the descending device attachment element. Carry out the tests first with the descent line in the general condition (see 4.15.2).

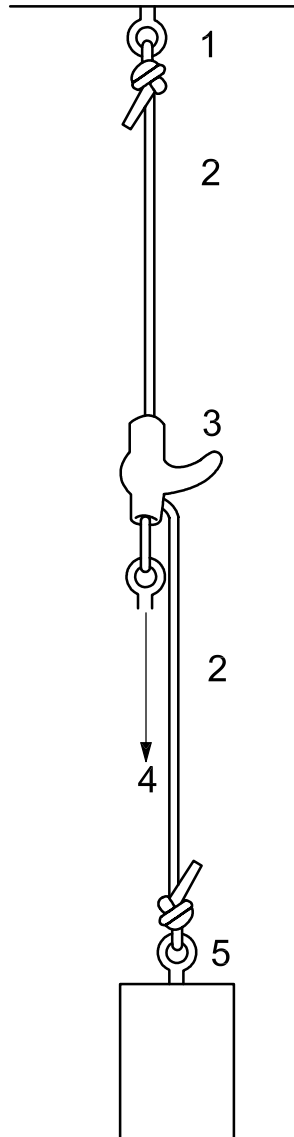

**Key**

- 1 anchor point
- 2 descent line
- 3 descending device
- 4 maximum rated load
- 5 mass

NOTE For descending devices controlled by the tail of the descent line, the mass is  $(20 \pm 0,25)$  kg. For descending devices not controlled by the tail of the descent line, the mass is  $(1 \pm 0,25)$  kg (removed after marking of the descent line).

**Figure 15 — Function test for types 2, 3, 4, 5 and 6 descending devices that travel with the user**

**5.8.2.2 Descending devices that are intended to be controlled manually by the tail of the descent line**

**5.8.2.2.1** For type 2 descending devices that incorporate a hands-free locking feature and for types 3 and 4 descending devices, allow the descent control element to adopt its hands-free locked position if it is going to be operated by a person during the test or, if it is not going to be operated by a person during the test, fix the descent control element by any suitable means in its fully open (minimum friction) position. In each case, take into account any specific instructions from the manufacturer relating to the diameter of the descent line.

**5.8.2.2.2** For type 2 descending devices that do not incorporate a hands-free locking feature and for types 5 and 6 descending devices, set the descent line in the descending device to the minimum friction configuration in accordance with the information supplied by the manufacturer, taking into account any specific instructions from the manufacturer relating to the diameter of the descent line.

**5.8.2.2.3** Attach a mass of  $(20 \pm 0,25)$  kg to the end of the descent line at a distance of  $(1\,500 \pm 100)$  mm beneath the descending device. Ensure that the test mass attached to the descending device does not interfere with the descent line. Place a mark at any point on the descending device. Mark the descent line at  $(250 \pm 5)$  mm below the mark on the descending device. Place another mark on the descent line  $(500 \pm 5)$  mm below the first mark on the descent line. Ensure that at all times during the test procedure the mass is suspended from the descent line.

**5.8.2.2.4** Within 30 s of marking the descent line, remove any restraint placed earlier to stop movement of the descending device down the descent line. For type 2 descending devices that incorporate a hands-free locking feature and for types 3 and 4 descending devices, if the descent control element is to be operated by a person, operate it so that the maximum speed is obtained (e.g. with the descent control element in the fully open position). For all types of descending device, do not grip or hold the descent line.

**5.8.2.2.5** Observe any movement of the descending device along the descent line and record the time taken for the mark on the descending device to pass between the two marks on the descent line. The distance between the mark on the descending device and the first mark (at 250 mm) on the descent line is used to allow the descending device or operator to settle in and is not part of the test. Confirm that the requirements of 4.13.2.1 are met.

**5.8.2.2.6** Repeat the test with the descending device and descent line conditioned to wet (see 4.15.3). Confirm that the requirements of 4.13.2.1 are met.

**5.8.2.2.7** If the manufacturer claims that the descending device and descent line can be used in the temperature range between  $-4\text{ °C}$  and  $+2\text{ °C}$ , repeat the test with the descending device and descent line conditioned to wet and cold (see 4.15.4). Confirm that the requirements of 4.13.2.1 are met.

### **5.8.2.3 Descending devices that are normally not intended to be controlled manually by the tail of the descent line**

**5.8.2.3.1** For type 2 descending devices that incorporate a hands-free locking feature and for types 3 and 4 descending devices, fix the descent control element by any suitable means in its fully open (minimum friction) position, taking into account any specific instructions from the manufacturer relating to the diameter of the descent line.

**5.8.2.3.2** For type 2 descending devices that do not incorporate a hands-free locking feature and for types 5 and 6 descending devices, set the descent line in the descending device to the minimum friction configuration in accordance with the information supplied by the manufacturer, taking into account any specific instructions from the manufacturer relating to the diameter of the descent line.

**5.8.2.3.3** Attach a mass of  $(1 \pm 0,25)$  kg to the end of the descent line at a distance of  $(4\,700 \pm 100)$  mm beneath the descending device. Place a mark at any point on the descending device. Mark the descent line at  $(250 \pm 5)$  mm below the mark on the descending device. Place another mark on the descent line  $(4000 \pm 20)$  mm below the first mark on the descent line. Remove the 1 kg mass from the descent line. Ensure that the test mass attached to the descending device does not interfere with the descent line. Ensure that at all times during the test procedure the mass is suspended from the descent line.

**5.8.2.3.4** Within 2 min of marking the descent line, remove any restraint placed earlier to stop movement of the descending device down the descent line. Do not grip or hold the descent line.

**5.8.2.3.5** Observe any movement of the descending device along the descent line and record the time taken for the mark on the descending device to pass between the two marks on the descent line. The distance between the mark on the descending device and the first mark (at 250 mm) on the descent line is used to allow the descending device to settle in and is not part of the test. Confirm that the requirements of 4.13.2.2 are met.

**5.8.2.3.6** Repeat the test with the descending device and descent line conditioned to wet (see 4.15.3). Confirm that the requirements of 4.13.2.2 are met.

**5.8.2.3.7** If the manufacturer claims that the descending device and descent line can be used in the temperature range between  $-4\text{ °C}$  and  $+2\text{ °C}$ , repeat the test with the descending device and descent line conditioned to wet and cold (see 4.15.4). Confirm that the requirements of 4.13.2.2 are met.

### **5.8.3 Types 2, 3, 4, 5 and 6 descending devices that normally do not travel with the user**

#### **5.8.3.1 Test set-up**

For descending devices that normally do not travel with the user during a descent, if the descending device is not already attached to the descent line, attach the descending device to the descent line in accordance with the information supplied by the manufacturer. If the descending device is intended to accept a range of diameters of descent line, use the minimum diameter of descent line as marked on the descending device in accordance with point i) of Clause 6. Attach the descending device by its attachment element to the anchor point of the test apparatus, using an appropriate connector. Restrain the descent line so that it cannot move through the descending device until the test commences. Attach a mass equivalent to the maximum rated load to the down-line end of the descent line (see Figure 16).

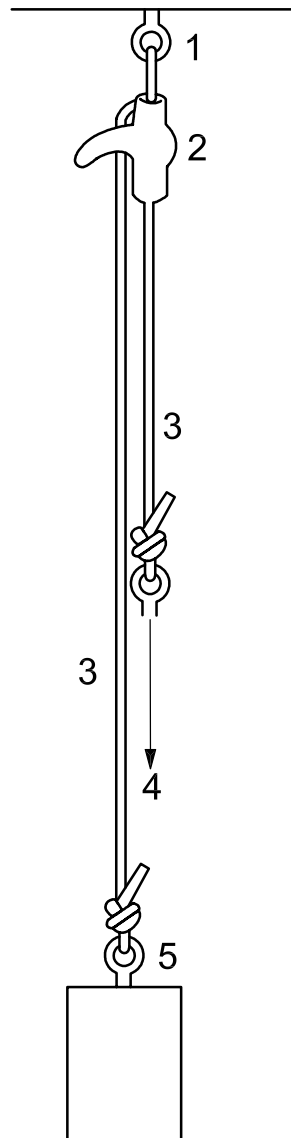

### Key

- 1 anchor point
- 2 descending device
- 3 descent line
- 4 maximum rated load
- 5 mass

NOTE For descending devices controlled by the tail of the descent line, the mass is  $(20 \pm 0,25)$  kg. For descending devices not controlled by the tail of the descent line, the mass is  $(1 \pm 0,25)$  kg (removed after marking of the descent line).

**Figure 16 — Function test for types 2, 3, 4, 5 and 6 descending devices that do not travel with the user**

### 5.8.3.2 Descending devices that are intended to be controlled manually by the tail of the descent line

**5.8.3.2.1** For type 2 descending devices that incorporate a hands-free locking feature and for types 3 and 4 descending devices, allow the descent control element to adopt its hands-free locked position, if it is going to be operated by a person during the test or, if it is not going to be operated by a person during the test, fix the descent control element by any suitable means in its fully open (minimum friction) position. In each case, take into account any specific instructions from the manufacturer relating to the diameter of the descent line.

**5.8.3.2.2** For type 2 descending devices that do not incorporate a hands-free locking feature and for types 5 and 6 descending devices, set the descent line in the descending device to the minimum friction configuration in accordance with the information supplied by the manufacturer, taking into account any specific instructions from the manufacturer relating to the diameter of the descent line.

**5.8.3.2.3** Attach a mass of  $(20 \pm 0,25)$  kg to the up-line end of the descent line at a distance of  $(1\ 500 \pm 100)$  mm from the descending device. Ensure that the test mass attached to the descent line does not interfere with the descending device. Place a mark at any point on the descending device. Mark the up-line descent line at  $(250 \pm 5)$  mm below the mark on the descending device. Place another mark on the descent line  $(500 \pm 5)$  mm below the first mark on the descent line. Ensure that at all times during the test procedure the mass is suspended from the descent line.

**5.8.3.2.4** Within 30 s of marking the descent line, remove any restraint placed earlier to stop movement of the mass representing the maximum rated load. For type 2 descending devices that incorporate a hands-free locking feature and for types 3 and 4 descending devices, if the descent control element is to be operated by a person, operate the control element of the descending device so that the maximum speed is obtained (e.g. with the descent control element in the fully open position). For all types of descending device, do not grip or hold the descent line.

**5.8.3.2.5** Observe any movement of the descent line through the descending device and record the time taken for the distance between the first and second marks on the descent line to pass the mark on the descending device. The distance between the mark on the descending device and the first mark (at 250 mm) on the descent line is used to allow the descending device or operator to settle in and is not part of the test. Confirm that the requirements of 4.13.2.3 are met.

**5.8.3.2.6** Repeat the test with the descending device and descent line conditioned to wet (see 4.15.3). Confirm that the requirements of 4.13.2.3 are met.

**5.8.3.2.7** If the manufacturer claims that the descending device and descent line can be used in the temperature range between  $-4\text{ °C}$  and  $+2\text{ °C}$ , repeat the test with the descending device and descent line conditioned to wet and cold (see 4.15.4). Confirm that the requirements of 4.13.2.3 are met.

### **5.8.3.3 Descending devices that are normally not intended to be controlled manually by the tail of the descent line**

**5.8.3.3.1** For type 2 descending devices that incorporate a hands-free locking feature and for types 3 and 4 descending devices, fix the descent control element by any suitable means in its fully open (minimum friction) position, taking into account any specific instructions from the manufacturer relating to the diameter of the descent line.

**5.8.3.3.2** For type 2 descending devices that do not incorporate a hands-free locking feature and for types 5 and 6 descending devices, set the descent line in the descending device to the minimum friction configuration in accordance with the information supplied by the manufacturer, taking into account any specific instructions from the manufacturer relating to the diameter of the descent line.

**5.8.3.3.3** Attach a mass of  $(1 \pm 0,25)$  kg to the up-line end of the descent line at a distance of  $(4\ 700 \pm 100)$  mm from the descending device. Place a mark at any point on the descending device. Mark the up-line descent line at  $(250 \pm 5)$  mm below the mark on the descending device. Place another mark on the descent line  $(4\ 000 \pm 20)$  mm below the first mark on the descent line. Remove the 1 kg mass from the descent line. Ensure that the test mass attached to the descent line does not interfere with the descending device. Ensure that at all times during the test procedure the mass is suspended from the descent line.

**5.8.3.3.4** Within 2 min of marking the descent line, remove any restraint placed earlier to stop movement of the descent line through the descending device. Do not grip or hold the descent line.

**5.8.3.3.5** Observe any movement of the descent line through the descending device and record the time taken for the distance between the first and second marks on the descent line to pass the mark on the descending device. The distance between the mark on the descending device and the first mark (at 250 mm)

on the descent line is used to allow the descending device to settle in and is not part of the test. Confirm that the requirements of 4.13.2.4 are met.

**5.8.3.3.6** Repeat the test with the descending device and descent line conditioned to wet (see 4.15.3). Confirm that the requirements of 4.13.2.4 are met.

**5.8.3.3.7** If the manufacturer claims that the descending device and descent line can be used in the temperature range between  $-4\text{ }^{\circ}\text{C}$  and  $+2\text{ }^{\circ}\text{C}$ , repeat the test with the descending device and descent line conditioned to wet and cold (see 4.15.4). Confirm that the requirements of 4.13.2.4 are met.

## 5.9 Corrosion resistance

**5.9.1** The apparatus for the corrosion resistance test shall conform to 5.1.5.

**5.9.2** Expose the descending device to the neutral salt spray test in accordance with ISO 9227 for a period of  $(24^{+0,5}_0)$  h. Dry for  $(60^{+5}_0)$  min at  $(20 \pm 2)$  °C. Then repeat the procedure, so that the descending device is subjected in total to 24 h exposure and  $(60^{+5}_0)$  min drying plus another 24 h exposure and  $(60^{+5}_0)$  min drying.

**5.9.3** Examine the specimen. Where necessary to gain visual access to internal components, dismantle the descending device. Confirm that the requirements of 4.14 are met.

## 6 Marking

Descending devices shall be clearly, indelibly and permanently marked by the manufacturer. Descending devices that are permanently or semi-permanently installed may carry the marking on a plate fitted adjacent to the descending device. If text is used for marking, it shall be in the official language(s) of the country of destination. Marking shall be by any suitable method not having harmful effect on the materials so marked and shall include at least the following:

- a) the manufacturer's name or trade mark or other means of identification;
- b) the model/type identification mark;
- c) the number of this International Standard, at least the last two digits of its year of publication and the type of descending device (e.g. "ISO 22159:07/3") and, if the descending device is type 1 or type 2, the class (e.g. "ISO 22159:07/2/B");
- d) the manufacturer's production batch or serial number or other means of traceability;
- e) a pictogram (see Figure 17) to indicate that users shall read the information supplied by the manufacturer (see ISO 7000:2004, symbol 1641);
- f) where applicable, markings showing the attachment element intended for the user to attach him/herself to the descending device or system (for descending devices that do not accompany the user, this could be the end of the descent line);
- g) the minimum and maximum rated load, in kilograms, to be used with the descending device;
- h) for types 1 and 2 descending devices, the maximum height of descent, in metres;
- i) for descending devices that allow or require assembly on to the descent line by any person other than the manufacturer:
  - the type and diameter range of descent line preceded by the symbol  $\emptyset$ ;
  - markings that provide clear information on how the descent line should be fitted to the descending device, which should include at least the correct descent line path and the correct direction of travel;

- j) for class D descending devices, a pictogram as shown in Figure 18 to indicate that the descending device shall only be used once, or not used more than once until verified in writing by the manufacturer or authorized representative that it is safe to do so;
- k) for type 2 class D descending devices, a warning either on or with the product that it is intended for single use emergency egress only, by trained and competent personnel who as part of their training have experienced a descent using this type of descending device.

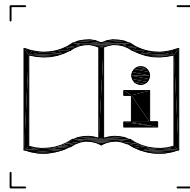

Figure 17 — Pictogram (ISO 7000-1641) to indicate that users shall read the information supplied by the manufacturer

Max = 1 x ↓

Figure 18 — “Use once only” marking for class D descending devices

## 7 Information supplied by the manufacturer

### 7.1 General

**7.1.1** For each descending device, the manufacturer shall supply instructions for use, for maintenance, for periodic detailed inspection and (where appropriate) for repair, including the descent line where the descent line is integrated with the descending device, in the official languages of the country of destination.

**7.1.2** The instructions for use in 7.2.2 a) to 7.2.2 gg) and 7.4 a) are designated as primary instructions for use and shall be provided in a printed format (but may be supplemented in another format). Other information required by this International Standard to be provided by the manufacturer shall be either in a printed format or via a printable electronic format, e.g. CD-ROM or Internet. If this information is available only in a printable electronic format, the primary instructions for use shall contain clear and unambiguous information on how to access and print it. Information provided via a printable electronic format shall be available in a printed format from the manufacturer upon request. The size of text of information provided in a printed format shall be a minimum of 6 pt.

**7.1.3** Information supplied by the manufacturer shall contain a reference number or code to enable traceability back to the descending device, and the descent line if integrated with the descending device.

**NOTE** The instructions for use, for maintenance, for periodic examination and for repair can be supplied in separate documents.

### 7.2 Instructions for use

**7.2.1** The instructions for use shall contain appropriate detail, supplemented by diagrams if necessary, to enable the descending device and descent line to be used correctly and safely.



**7.2.2** The instructions for use shall include:

- a) the name and contact details of the manufacturer or authorized representative as appropriate;
- b) advice that the user (i.e. the operative) should read and understand the instructions for use before using the descending device;
- c) the meaning of any markings on the descending device and also the meaning of any markings on the descent line if it is incorporated in the descending device (i.e. types 1 and 2 descending devices);
- d) the type of the descending device in accordance with this International Standard and, where appropriate, the class;
- e) statements describing the descending device, its intended purpose, application and limitations, including (for types 1 and 2 descending devices) advice that only manufacturer-approved descent lines supplied with the descending device shall be used;
- f) advice on which attachment elements of the descending device are for attachment to the user and/or to the anchor point;
- g) the type and diameter of descent line to be used: special care should be taken to inform the user of the types of descent line for which the descending device is designed, including applicable standards (this requirement is optional for types 1 and 2 descending devices);
- h) if the descent line is not integral to the descending device, how to insert and extract the descent line;
- i) for types 1 and 2 descending devices, the maximum descent distance allowed;
- j) for descending devices using or recommending descent lines made from stainless steel wire or textiles containing aramid fibres, the maximum number of descents allowed in relation to the descent distance (see 4.2.2.4, 4.2.3.3 and 5.5.6), e.g. by means of a table;
- k) for class D descending devices, a warning that the device shall only be used once, or not used more than once until verified in writing by the manufacturer or authorized representative that it is safe to do so;
- l) for type 2 class D descending devices, a warning that the descending device is intended for emergency egress (single use) only, by trained and competent personnel who as part of their training have experienced a descent using this type of descending device;
- m) a warning that the descending device should only be used by a person competent in its use or following clear emergency protocols, and a recommendation that practical training be carried out to establish competency;
- n) for types 4, 5 and 6 descending devices, a warning that when used in work or training applications, care should be taken to protect the user from uncontrolled descent by the use of a safety back-up system, unless a risk assessment has indicated exceptional circumstances (e.g. emergency egress) whereby the use of such a system would increase the danger to the user; and for other types of descending device, advice that consideration should be given to the use of a safety back-up, particularly during training;
- o) a warning that plans should be in place to deal with any emergencies that could arise;
- p) a warning against making any alterations or additions to the descending device without the manufacturer's prior written consent, and that any repair should only be carried out in accordance with the manufacturer's procedures;
- q) a warning that the descending device should not be used outside its limitations or for any purpose other than that for which it is intended;

- r) for any descending device that requires control of the tail of the descent line, a warning that it is vital to keep control of the tail of the descent line to reduce the risk of serious injury or death;
- s) a warning that it is vital to descend slowly and always in control because loss of control may be difficult to recover;
- t) a warning that the descending device may be hot during or after a descent and that long or rapid descents or descents with heavy loads may generate excessive heat, which might damage the descent line or injure the user if parts other than those used to control the descent are touched;
- u) for types 3 to 6 descending devices that exceed the temperatures cited in 4.11, a warning which states at least: "Beware high temperatures on the exterior and interior of the descending device!";
- v) where appropriate, the means or method to allow the descending device to be tied or locked-off manually, to permit hands-free suspension of the user;
- w) sufficient information to ensure the compatibility of items of other equipment when assembled with the descending device in a system, especially connectors, body-holding devices, anchors and descent lines;
- x) a warning about the danger that may arise by the use of combinations of items of equipment in which the safe functioning of any one item is affected by or interferes with the safe functioning of another;
- y) a warning to emphasize that it is essential for safety that the anchor point for the descent line is appropriate for its intended use, particularly with regard to its strength and location, and that it should always be positioned, and the descent carried out, in such a way as to prevent a fall;
- z) advice describing foreseeable hazards which could result from incorrect use of the descending device and descent line, e.g. sharp edges, slack in the descent line, inadvertently descending off the end of the descent line, inadvertent disconnection of the descending device from the connector linking it to the user;
- aa) an instruction and criteria to enable the user to carry out a pre-use check of features essential to the proper functioning of the descending device and other components in the system to ensure that it is in a serviceable condition and operates correctly before it is used;

NOTE A pre-use check by the user of certain parts of equipment for emergency use that have been pre-packed or sealed by a competent person is not necessarily applicable.

- bb) a warning stating that it is essential for safety that the descending device and any other components in the system be withdrawn from use immediately and not used again until confirmed by a competent person in writing that it is acceptable to do so should
  - 1) any doubt arise about their condition for safe use, or
  - 2) they have been used to arrest a fall.
- cc) installation or mounting instructions where appropriate;
- dd) instructions on correct storage and how to protect against damage during transportation (see also Annex A);
- ee) a statement of any known limit to the safe useable life of the product or any part of the product;
- ff) the ambient temperature range in which the descending device may be used;
- gg) advice on where to obtain additional information and updates to these instructions (e.g. website/postal address) and what the additional information covers;
- hh) advice on how to determine when the descending device, including the descent line if integrated with the descending device, is no longer safe to use;

- ii) information on known hazards that may affect the performance of the equipment and corresponding safety precautions that should be observed, e.g. extremes of temperature, trailing or looping of descent lines over sharp edges, chemical reagents, electrical conductivity, cutting, abrasion, climatic exposure, pendulum falls;
- jj) for types 1 and 2 descending devices, advice drawing attention to the record card and the need to carry out a detailed inspection by a competent person when required;
- kk) for descending devices with descent lines made of stainless steel or containing aramid fibres, advice on the maximum number of descents allowed before service and/or line replacement;
- ll) a statement that descending devices installed at a workstation and left in place between inspections should be protected adequately against environmental conditions;
- mm) a warning that it is essential for the safety of the user that if the product is re-sold outside the original country of destination, the reseller should provide instructions for use, for maintenance, for periodic detailed inspection and for repair, in the language of the country in which the product is to be used.

### 7.3 Instructions for maintenance

**7.3.1** The maintenance instructions shall be supplemented by diagrams, if necessary, to enable the descending device, and descent line if integrated with the descending device, to be maintained correctly and safely.

**7.3.2** The maintenance instructions shall include:

- a) cleaning procedures (including disinfection, where applicable) not causing adverse effect to the materials used in the manufacture of the descending device, and descent line if integrated with the descending device, or to the user, and a warning that the procedures are to be strictly adhered to;
- b) where appropriate, a warning that when the descending device, and descent line if integrated with the descending device, becomes wet, either from being in use or due to cleaning, it should be allowed to dry naturally and should be kept away from direct heat;
- c) storage procedures, including all necessary preventative requirements where environmental or other factors could affect the condition of the descending device, and descent line if integrated with the descending device, e.g. damp environment, sharp edges, vibration;
- d) other maintenance procedures as relevant to the descending device, e.g. lubrication.

### 7.4 Instructions for periodic detailed inspections

Instructions for periodic detailed inspections shall include:

- a) a warning to emphasize the need for regular periodic detailed inspections, and the fact that the safety of the user depends upon the continued efficiency and durability of the descending device and descent line;
- b) a recommendation with regard to the frequency of periodic detailed inspections, taking account of such factors as legislation, equipment type, frequency of use, and environmental conditions;

**NOTE** The maximum period recommended between periodic detailed inspections could vary depending on the factors outlined, but it is advisable that this period be a maximum of twelve months, except where alternative arrangements are agreed with the manufacturer for particular equipment in particular circumstances of use.

- c) a warning to emphasize that periodic detailed inspections shall only be conducted by a competent person for periodic detailed inspection and strictly in accordance with the manufacturer's periodic detailed inspection procedures;

- d) where deemed necessary by the manufacturer (e.g. due to the complexity or innovation of the descending device, or where safety-critical knowledge is needed in the dismantling, re-assembly or assessment of it), an instruction specifying that periodic detailed inspections should only be conducted by the manufacturer or by a person or organization authorized by the manufacturer.

### **7.5 Instructions for repair**

Where the manufacturer permits repair, written repair instructions shall be supplied in the official languages of the country in which the item is in service. These instructions shall include a statement to the effect that any repair shall only be conducted by a person competent to carry out repair and who has been authorized by the manufacturer, and that the repair procedure shall be strictly in accordance with the manufacturer's instructions.

### **7.6 Records**

Advice shall be given that a record is kept for each descending device, descent line and other components in the system. The record should contain advice on the need to carry out periodic detailed inspections as required, and that these should only be carried out by a competent person. The record should include headings for and spaces to allow entry of the following details:

- a) the type of the equipment (e.g. descending device) and its trade name;
- b) the name and contact details of the manufacturer;
- c) a means of identification (e.g. the batch or serial number);
- d) the year of manufacture;
- e) the date of purchase;
- f) any other information as necessary (e.g. maintenance and frequency of use);
- g) the date when it is first put into use;
- h) a record of periodic detailed inspections and repairs, to include:
  - 1) the dates and details of each periodic detailed inspection and repair, and the name and signature of the competent person who carried out the periodic detailed inspection or repair;
  - 2) the next due date for periodic detailed inspection;
  - 3) for descending devices types 1 and 2 and for descending devices utilizing or recommending descent lines made from stainless steel wire or textiles containing aramid fibres, the maximum number of descents allowed before service and/or line replacement.

**Annex A**  
(informative)

**Packaging**

Manufacturers should take all reasonable care to ensure that descending devices (and other accompanying components) are packaged to prevent damage and deterioration during transportation.

Where severe environmental conditions exist, or special conditions of supply are specified (e.g. for long-term storage or transportation requirements), arrangements should be specified by the purchaser and agreed by the manufacturer.

## **Annex B** (informative)

### **Functional recommendations for the use of descending devices in the workplace**

#### **B.1 General**

This is a non-exhaustive list of functional recommendations for the use of descending devices used in the workplace.

It is important for potential users to be aware that the test methods in this International Standard do not describe the actual method of use.

Descending devices in combination with descent lines and other equipment are widely used for work positioning and rope access. These techniques require the user to be highly trained and competent, and to be aware of the limitations of such systems. An understanding of the principle of double protection, i.e. a working line plus a safety line, is essential for users. Descending devices used in the workplace should always be used in conjunction with a safety line and back-up device. The function of the safety line is to provide a back-up to the working line. A single line used in tension is not a safety line; it is the working line.

Descending devices are sometimes designed exclusively for rescue, e.g. type 1 descending devices, where it is normal not to have a safety back-up because these descend automatically within a certain speed range.

#### **B.2 Maintaining the descending device within the user's reach**

If the descending device travels with the user, it is important that the user always keeps the descending device within reach. (The same also applies to any back-up device used in the descent system.). Descending devices are normally most efficient when they are attached directly (usually via a connector) to a low attachment point on the harness. (For back-up devices, the length of the lanyard between the back-up device and the harness should be limited to a person's reach, which will vary from user to user.)

#### **B.3 Anticipation of emergency situations**

When using descending systems, it is necessary for users to anticipate and plan for emergency situations. The length of descent lines and types of equipment available at the work site are important considerations, as are hazard identification, risk assessment, risk control and rescue training.

#### **B.4 Care when selecting descent lines**

Where descending devices are not supplied with an integrated descent line, it is very important that care is taken in selecting the correct descent line for the descending device, and that the information supplied by the manufacturer is followed. Different types of descent lines may change the characteristics and safe functioning of descending devices. Important factors when selecting descent lines are:

- the construction of the sheath;
- any surface treatment of the sheath;
- the diameter of the descent line.

It is also important to be aware that the characteristics of the descent line may change in use, especially due to wear, dirt or repeated descents over the same part of the descent line within a short time period.

When selecting metal descent lines, care should be taken to ensure there is no unacceptable reaction with the metals used in the descending device, e.g. a reaction that could cause galvanic corrosion.

## Bibliography

- [1] ISO 7000:2004, *Graphical symbols for use on equipment — Index and synopsis*
- [2] ISO 9001, *Quality management systems — Requirements*
- [3] ISO 10333-5, *Personal fall-arrest systems — Part 5: Connectors with self-closing and self-locking gates*
- [4] AS/NZS 4142.3, *Fibre ropes — Man-made fibre rope for static life rescue lines*
- [5] CI-1801, *Low Stretch/Static Kernmantle Safety Rope*
- [6] CAN/CSA Z259.12, *Connecting Components for Personal Fall Arrest Systems (PFAS)*
- [7] EN 362, *Personal protective equipment against falls from a height — Connectors*
- [8] EN 563:1994, *Safety of machinery — Temperatures of touchable surfaces — Ergonomics data to establish temperature limit values for hot surfaces*
- [9] EN 1891, *Personal protective equipment for the prevention of falls from a height — Low stretch kernmantel ropes*





