

INTERNATIONAL STANDARD

ISO 21849

First edition
2006-12-01

Aircraft and space — Industrial data — Product identification and traceability

*Aéronautique et espace — Données industrielles — Identification des
produits et traçabilité*



Reference number
ISO 21849:2006(E)

© ISO 2006

PDF disclaimer

This PDF file may contain embedded typefaces. In accordance with Adobe's licensing policy, this file may be printed or viewed but shall not be edited unless the typefaces which are embedded are licensed to and installed on the computer performing the editing. In downloading this file, parties accept therein the responsibility of not infringing Adobe's licensing policy. The ISO Central Secretariat accepts no liability in this area.

Adobe is a trademark of Adobe Systems Incorporated.

Details of the software products used to create this PDF file can be found in the General Info relative to the file; the PDF-creation parameters were optimized for printing. Every care has been taken to ensure that the file is suitable for use by ISO member bodies. In the unlikely event that a problem relating to it is found, please inform the Central Secretariat at the address given below.

© ISO 2006

All rights reserved. Unless otherwise specified, no part of this publication may be reproduced or utilized in any form or by any means, electronic or mechanical, including photocopying and microfilm, without permission in writing from either ISO at the address below or ISO's member body in the country of the requester.

ISO copyright office
Case postale 56 • CH-1211 Geneva 20
Tel. + 41 22 749 01 11
Fax + 41 22 749 09 47
E-mail copyright@iso.org
Web www.iso.org

Published in Switzerland

Contents

Page

Foreword.....	iv
Introduction	v
1 Scope	1
2 Normative references	1
3 Terms and definitions.....	2
4 Product/part identification and traceability process.....	3
4.1 General provisions	3
4.2 Product/part identification and traceability decision tree diagram	4
4.3 Conformance classes.....	5
5 Conformance Class 1	5
5.1 Purpose.....	5
5.2 Detailed requirements	6
6 Conformance Class 2	9
6.1 Purpose.....	9
6.2 Detailed requirements	10
6.3 Recommended process	10
7 Data formats	10
7.1 General.....	10
7.2 Text Element Identifiers	11
7.3 EAN.UCC Application Identifiers.....	11
7.4 ASC MH10 Data Identifiers.....	12
8 Product/part marking.....	12
8.1 Direct.....	12
8.2 Label or nameplate	12
8.3 Marking symbology	12
8.4 Marking layout.....	13
8.5 Human translation	14
8.6 Extended data content	15
8.7 Limited marking space procedure	16
8.8 General requirements for permanent product/part identification	17
8.9 Detailed requirements for symbols.....	17
Annex A (normative) Data dictionary: Essential data elements.....	19
Annex B (normative) Data dictionary: Optional/other data elements	28
Annex C (informative) Life cycle traceability.....	46
Annex D (normative) EAN.UCC Application Identifier (AI) equivalencies	48
Annex E (normative) ASC MH10 Data Identifier (DI) (codified in ISO/IEC 15418) equivalencies	49
Annex F (normative) Encoding comparison.....	51
Annex G (informative) Legacy part identification schema.....	52
Annex H (informative) Data exchange.....	53
Annex I (informative) RFID tag	55
Annex J (informative) Quality level, directly marked matrix symbols	57
Bibliography	58

Foreword

ISO (the International Organization for Standardization) is a worldwide federation of national standards bodies (ISO member bodies). The work of preparing International Standards is normally carried out through ISO technical committees. Each member body interested in a subject for which a technical committee has been established has the right to be represented on that committee. International organizations, governmental and non-governmental, in liaison with ISO, also take part in the work. ISO collaborates closely with the International Electrotechnical Commission (IEC) on all matters of electrotechnical standardization.

International Standards are drafted in accordance with the rules given in the ISO/IEC Directives, Part 2.

The main task of technical committees is to prepare International Standards. Draft International Standards adopted by the technical committees are circulated to the member bodies for voting. Publication as an International Standard requires approval by at least 75 % of the member bodies casting a vote.

Attention is drawn to the possibility that some of the elements of this document may be the subject of patent rights. ISO shall not be held responsible for identifying any or all such patent rights.

ISO 21849 was prepared by Technical Committee ISO/TC 20, *Aircraft and space vehicles*.

This first edition of ISO 21849 cancels and replaces ISO/TS 21849:2003, which has been technically revised.

Introduction

The accuracy of data collected and exchanged by trading partners can be improved by using automatic identification technologies in lieu of manual key entry. Automatic identification technologies include matrix symbologies, linear bar code and radio frequency identification (RFID) tags.

Employment of automatic identification technology provides an accurate, timely and efficient method of data entry and facilitates data transfer and storage for computerized information management systems.

This International Standard defines and establishes a repeatable process and data structure for product identification and traceability that supports life cycle management of a product regardless of ownership and configuration changes. Use of the product identification and traceability guidelines described in this International Standard will enable repeatable processes for error free data entry, part tracking, dispatch, inventory, maintenance, import/export, detection of unapproved parts and repairs. Most importantly, a repeatable process and data structure will allow industry partners to share data efficiently. The macro-processes of product data management, asset management, configuration management, reliability and maintenance management, and product performance management will be the direct beneficiaries of the product identification and traceability schema defined in this International Standard.

Establishment of a common set of data and well-defined definitions and formats for product identification and traceability provides the base on which to build specific requirements for the exchange of product life cycle information. The specific requirements that the product identification and traceability schema defined in this International Standard fulfils are as follows:

- to provide a unique, permanent identification for the life of the product;
- to provide a schema which meets engineering, operational, and logistics identification and traceability needs;
- to use machine-readable media to obtain accurate and timely data;
- to provide a schema which is independent of marking, symbology and recording media technology; and
- to provide a structure which allows data to be exchanged without the use of data mappers (cross-reference/translation tables), throughout an enterprise and with trading partners, while taking advantage of the World Wide Web.

The focus of this International Standard is industrial products within the aircraft and space sectors. Industrial products have a life cycle measured in years, normally are repairable, often are upgraded to a new configuration, and change of ownership over their life cycle is commonplace. Normally industrial products are not sold in the retail marketplace.

The decision to use automated identification processes should be a cooperative effort by trading partners within an industry and between industries to achieve more timely data input, data accuracy and the achievement of increased productivity while concurrently decreasing costs.

Aircraft and space — Industrial data — Product identification and traceability

1 Scope

This International Standard specifies the requirements for a product identification and traceability schema for life cycle management of aircraft and space products/parts. It specifies the minimum essential identification information needed for traceability of a product for its life cycle. It also provides the data structures for use with automatic identification technologies that support product/part life cycle data management activities.

This International Standard defines a structure and rules for establishing a unique identifier for product/part identification and traceability. The rules and structure provide sufficient options to support various business practices. They provide the minimum amount of standardization required to support interoperability, improved business processes and efficiency across multiple users and applications of machine-readable media technologies.

This International Standard also defines and establishes repeatable processes to allow efficient exchange of product data for life cycle product/part traceability, configuration, reliability, maintenance, and product performance management purposes.

It specifies the data carriers appropriate for representing the product data in a machine-readable form and associated dimensional and quality parameters.

Industries or trading partners will need to develop specific implementation guidelines to employ the principles defined in this International Standard.

Although primarily intended for aircraft and space products/parts, this International Standard may be used for other products/parts where desired.

2 Normative references

The following referenced documents are indispensable for the application of this document. For dated references, only the edition cited applies. For undated references, the latest edition of the referenced document (including any amendments) applies.

ISO/IEC 646, *Information technology — ISO 7-bit coded character set for information interchange*

ISO 8601, *Data elements and interchange formats — Information interchange — Representation of dates and times*

ISO 10303-239, *Industrial automation systems and integration — Product data representation and exchange — Part 239: Application protocol: Product life cycle support*

ISO/IEC 15415, *Information technology — Automatic identification and data capture techniques — Bar code print quality test specification — Two-dimensional symbols*

ISO/IEC 15416, *Information technology — Automatic identification and data capture techniques — Bar code print quality test specification — Linear symbols*

ISO 21849:2006(E)

ISO/IEC 15417, *Information technology — Automatic identification and data capture techniques — Bar code symbology specification — Code 128*

ISO/IEC 15418, *Information technology — EAN/UCC Application Identifiers and Fact Data Identifiers and Maintenance*

ISO/IEC 15434, *Information technology — Automatic identification and data capture techniques — Syntax for high-capacity ADC media*

ISO/IEC 15459 (all parts), *Information technology — Unique identifiers*

ISO/IEC 16022, *Information technology — Automatic identification and data capture techniques — Data Matrix bar code symbology specification*

ISO/IEC 16388, *Information technology — Automatic identification and data capture techniques — Bar code symbology specifications — Code 39*

ISO/IEC 18004, *Information technology — Automatic identification and data capture techniques — QR Code 2005 bar code symbology specification*

ISO/IEC 19762-1, *Information technology — Automatic identification and data capture (AIDC) techniques — Harmonized vocabulary — Part 1: General terms relating to AIDC*

ISO/IEC 19762-2, *Information technology — Automatic identification and data capture (AIDC) techniques — Harmonized vocabulary — Part 2: Optically readable media (ORM)*

Common Support Data Dictionary (CSDD), Air Transport Association

Extensible Markup Language (XML) 1.0, W3C

General EAN.UCC Specifications, EAN International

SAE AS9132 (EN9132) (SJAC9132), *Data Matrix Quality Requirements for Parts Marking*

3 Terms and definitions

For the purposes of this document, the terms and definitions given in ISO/IEC 19762-1, ISO/IEC 19762-2 and the following apply.

3.1

alphanumeric character set

character set that contains both letters and digits and may contain special characters

[ISO/IEC 2382-4]

3.2

conformance class

category of data representation specified in terms of the variability allowed for the data content

3.3

data delimiter

character or set of characters which separates data elements in a string of data elements

3.4

Enterprise Identifier

code uniquely assigned to an enterprise by an issuing agency that is assigned by the registration authority of ISO/IEC 15459

3.5**forward oblique stroke**

/

special character (character value 47 in ISO 646) used to separate data elements in a data string

3.6**in-service product/part**

product/part for which the original manufacturing process, including application of the identification symbology, has been completed and which is no longer an asset of the manufacturer or portion of the enterprise which owns the manufacturing process

3.7**limited marking space**

space available on the product/part which is insufficient for a machine-readable symbol and associated human translation representing the essential data for the conformance class

3.8**optional data**

data which is not essential to provide a unique identifier for product/part identification or configuration management/control (part number), but provides supplementary information relative to the product/part

NOTE Traceability data are an example of optional data.

3.9**syntax**

set of rules defining the way in which data is put together with appropriate identifiers, delimiters, separator character(s), and other non-data characters to form messages

NOTE Equivalent to grammar in spoken language.

3.10**Text Element Identifier****TEI**

string of four characters (three upper-case alpha characters followed by a space character) that precedes a given data field and defines the data that follow

4 Product/part identification and traceability process**4.1 General provisions**

In order that automated processes can be used to identify and facilitate “cradle to grave” traceability of products/parts, a product identification and traceability schema is defined in this International Standard.

The use of Text Element Identifiers is the preferred semantic for use in this process. EAN.UCC Application Identifiers or ASC MH10 Data Identifiers may be used with trading partner agreement.

The standard data and formats described herein are structured to be compatible/interoperable with most types of machine-readable media and human translation. Standard data formats for the identification of both new and in-service products/parts are provided. The use of two conformance classes allows the product identification schema to be widely employed.

The architecture of unique identification using a single data construct is defined in ISO/IEC 15459.

The applicable character set to be used for data encoding shall be the International Reference Version (IRV) of ISO/IEC 646.

For direct part marking, Data Matrix (in accordance with ISO/IEC 16022) or QR Code (in accordance with ISO/IEC 18004) shall be used. Direct part marking is considered the most permanent of the machine-readable media techniques for providing life cycle identification of products/parts.

NOTE Unless otherwise stated, this document uses the term “matrix symbol” to refer to both Data Matrix and QR Code symbols.

For labelling or nameplates, either a matrix symbol, as above, or linear bar codes, namely Code 128 (in accordance with ISO/IEC 15417) or Code 39 (in accordance with ISO/IEC 16388) shall be used.

This International Standard makes provision for the use of RFID tags for the representation of both static and dynamic data in a tag affixed to the part, to enable additional operational processes to be performed.

This International Standard also provides a legacy product/part identification schema, which is defined in Annex G.

4.2 Product/part identification and traceability decision tree diagram

Figure 1 below is a decision tree diagram which illustrates

- the product/part identification and traceability schema,
- the three essential product/part identification data elements, and
- the difference between a serialized and a non-serialized product/part.

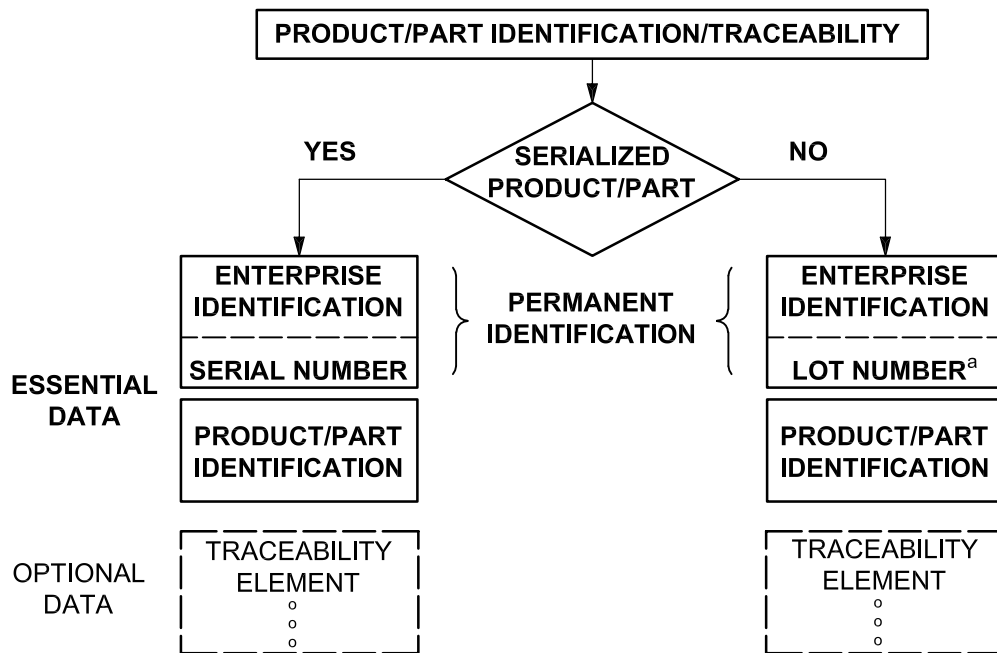

^a Permanent identification which shall be used for a lot of products/parts.

Figure 1 — Product/part identification and traceability decision tree diagram

Permanent identification for the life cycle of the product/part includes both the enterprise identification and the Serial or Lot Number contained in a matrix symbol or on a label. The product/part identification (part number), which is used primarily for configuration management, is in a separate/second matrix symbol or on a separate/second label. This schema allows the Product/Part Identification Number to be updated when the form, fit or function changes without altering the permanent identification matrix symbol or label.

4.3 Conformance classes

Permanent machine-readable media product/part identification has two approaches to the representation of data, known as conformance classes. The conformance classes shall apply to direct part marking, labels, nameplates, RFID tags and other forms of machine-readable media. The data elements associated with the two conformance classes are specified in Tables 1 and 2. Any stream of data complying with a conformance class specified in Table 1 or Table 2 may be input to product life cycle processes and be represented in machine-readable media.

Conformance Class 1 is the approach using only specified TEI data elements. Using specified well-defined data elements will minimize transmission, storage and retrieval times. Trading partners may agree on adding additional traceability data elements. Conformance Class 1 is intended for those products/parts which require life cycle traceability for decades; for example, industrial products like aircraft, ships, turbine engines and conveyance power generation equipment.

Conformance Class 2 provides a more flexible approach which could require more marking space and time to exchange data than Conformance Class 1. Conformance Class 2 provides examples of Product/Part Identifiers to be used in place of the precisely defined standardized data elements in Conformance Class 1. Conformance Class 2 is intended for use by trading partners who have Product/Part Identifiers already in place; for example, aircraft or ship hull number for which a business case cannot be made to change to Conformance Class 1 specific identification requirements. Trading partners shall agree on the Product/Part Identifiers to be used for Conformance Class 2, and may agree on additional data elements.

Trading partners will need to agree which conformance class to employ in order to obtain interoperability between multiple users, but Conformance Class 1 shall be the default if no agreement is in place.

5 Conformance Class 1

5.1 Purpose

Conformance Class 1 is an approach using only specified TEI data elements for product identification. It provides both for the identification of products and parts that are serialized and for the identification of those that are identified by lot.

5.2 Detailed requirements

Table 1 — Conformance Class 1

Essential data		
Data element	TEI	Valid values/size
Enterprise Identifier ^{a, b} CAGE/NCAGE DUNS EAN.UCC	CAG ^c DUN EUC	5 characters, alphanumeric 9 characters, numeric 6 to 13 characters, numeric
Unique Product/Part Serial Number ^{a, d, e} (for serialized products/parts only)	SER	1 to 15 characters, alphanumeric
Enterprise Lot Number ^e (for products/parts identified by lot only)	LTN	1 to 15 characters, alphanumeric
Current Product/Part Identifier ^f	PNR	1 to 15 characters, alphanumeric
Optional data		
Traceability element(s)	To be determined by trading partners	^g
<p>^a Permanent identification is the combination of the Enterprise Identifier and the Unique Product/Part Serial Number within the Enterprise Identifier. When using CAGE/NCAGE as the Enterprise Identifier, space may be saved by using a combined element. For a new product/part, the combined element TEI is USN (Universal Serial Number); for an in-service product/part, the combined element TEI is UST (Universal Serial Tracking Number).</p> <p>^b Selection of the Enterprise Identifier(s) to be used shall be determined by the trading partners.</p> <p>^c Where employed in existing applications, MFR shall be considered equal to CAG. As business conditions permit, MFR should be phased out in favour of CAG.</p> <p>^d Unique Product/Part Serial Number (SER) shall be assigned by the original manufacturer and shall be unique within the Enterprise Identifier of the manufacturer. If the serialization is being accomplished by an organization other than the original manufacturer, the TEI for Unique Component Identification Number (UCN) shall be used.</p> <p>^e SER shall be used for parts which are serialized and LTN for those which are identified by lot number. Only one of these TEIs shall be used.</p> <p>^f The Current Product/Part Identifier (PNR) shall be assigned by the organization responsible for configuration of the product/part. The responsible organization is normally engineering. The Current Product/Part Identifier shall be assigned to one or more like units which have the same form, fit and function. The Current Product/Part Identifier marking should be separate from the permanent identification marking so that it can be updated over the life cycle of the part when the form, fit or function changes. For a non-serialized part defined in an international/national standard, the part number should be assigned by the organization controlling the standard, e.g. AIA, SAE, etc.</p> <p>^g Traceability data element selection sequence precedence shall be as follows.</p> <ul style="list-style-type: none"> — First, as identified and defined in this International Standard. — Second, as identified and defined in the Air Transport Association (ATA) Common Support Data Dictionary (CSDD). <p>For a listing of additional data elements, contact ATA at the following address:</p> <p>Air Transport Association of America SPEC 2000 Program 1301 Pennsylvania Ave. N.W. Washington, D.C. 20004-1707 USA Phone: +1 202 626 4039 Fax: +1 202 626 4081</p>		

5.2.1 New serialized product/part requirements

5.2.1.1 Required data elements

For a new product/part, the following data elements are required.

- a) Permanent unique identification of the product/part throughout its life, in a matrix symbol, or on a data plate/label, or in an RFID tag. This shall consist of
- 1) an Enterprise Identifier for the manufacturer (CAG, DUN or EUC) (see A.1, A.3 and A.4), followed by
 - 2) a Unique Product/Part Serial Number (SER) (see A.7).

NOTE 1 When using CAGE/NCAGE as the Enterprise Identifier, space may be saved by using a combined element. The combined element TEI is USN (see A.8).

- b) Current Product/Part Identifier (PNR) (See A.2). This data element shall be in a second matrix symbol or data plate/label to easily allow for necessary changes over the life of the part (see Figures 2 b) and 3 b) for examples).

The Unique Product/Part Serial Number shall be a unique number within the manufacturer's Enterprise Identifier. The Unique Product/Part Serial Number shall remain constant during the life of the product/part, even if the Current Product/Part Identifier is changed due to a form, fit or function change. Only the original manufacturer shall use the Unique Product/Part Serial Number. All others shall use the Unique Component Identification Number (UCN) (see A.6).

NOTE 2 Annexes D and E identify the equivalent Application Identifiers and Data Identifiers to use in the product/part identification schema defined in this International Standard.

5.2.1.2 Optional traceability data elements

The optional traceability data elements shall be agreed between trading partners. When matrix symbols are being used, the optional traceability data elements shall be contained in a separate matrix symbol (i.e. a third symbol, additional to those provided for by 5.2.1.1 a) and b). For an RFID tag, the traceability data elements shall follow the essential data elements. Refer to Table 1, footnote g for the order of preference when selecting traceability data elements.

5.2.2 In-service serialized product/part requirements

For a serialized product/part that is already in service, the current product/part owner should first contact the original manufacturer to determine if the company will provide a Unique Product/Part Serial Number within their appropriate Enterprise Identifier. If agreement is obtained, the requirements specified in 5.2.1 apply. If agreement cannot be obtained from the original manufacturer, or the original manufacturer is out of business, the data elements listed below shall be applied. Either the combination of the original manufacturer's Enterprise Identifier and Unique Product/Part Serial Number or the current owner's Enterprise Identifier and Unique Component Identification Number shall be the permanent identification for an in-service serialized product/part.

- a) Permanent identification for the product/part, consists of the following.
- 1) The current owner's appropriate Enterprise Identifier (CAG, DUN or EUC) (see A.1, A.3 and A.4).
 - 2) A Unique Component Identification Number (UCN) (see A.6) assigned by the current owner in place of a Unique Product/Part Serial Number. The UCN number shall be unique within the owner's appropriate Enterprise Identifier.

NOTE UCN is used when serialization is accomplished by an organization other than the original manufacturer of the product/part.

- 3) When using CAGE/NCAGE as the Enterprise Identifier, space may be saved by using a combined element. The combined element TEI is UST (see A.9).
- b) For the Current Product/Part Identifier (PNR), the requirements specified in 5.2.1.1 apply.

5.2.3 Examples of serialized product/part marking

Figures 2 and 3 are illustrative only and show examples based on the CAGE/NCAGE Code Enterprise Identifier. They are not necessarily to scale; encoded data may not meet the quality requirements specified in this International Standard.

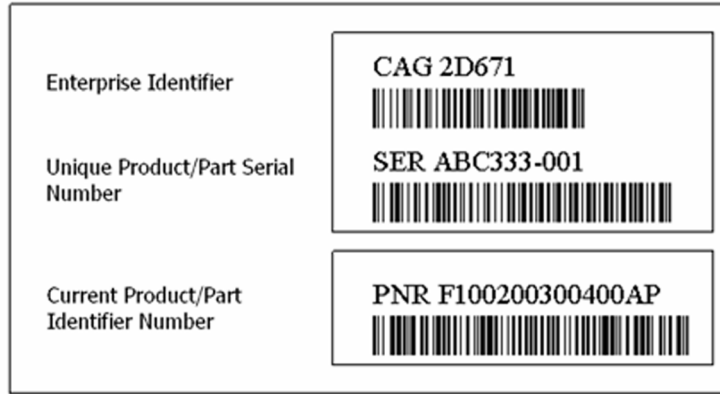

a) Data encoded in Code 128 format

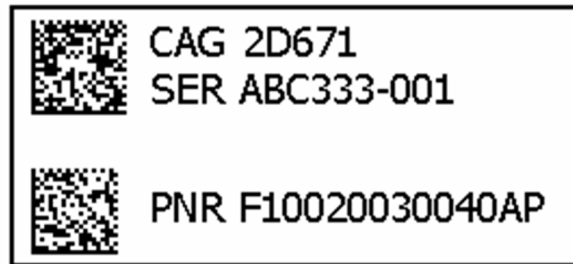

b) Data encoded in Data Matrix format with human translation added

Figure 2 — New product/part

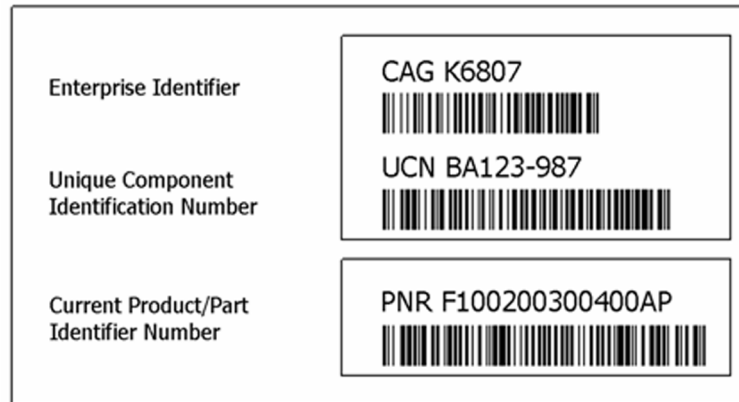

a) Data encoded in Code 128 format

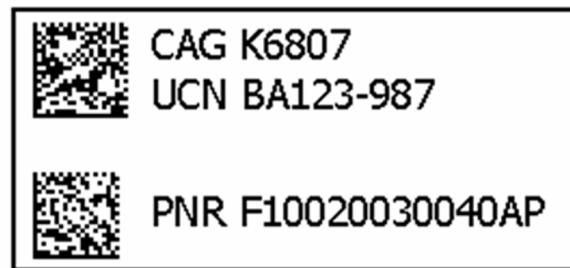

b) Data encoded in Data Matrix format with human translation added

Figure 3 — In-service product/part or where serial number not assigned by the original manufacturer

5.2.4 Requirements for product/parts identified by lot

Subclauses 5.2.1 and 5.2.2 apply, except that Enterprise Lot Number (LTN) (see A.5) shall replace Unique Product/Part Serial Number (SER).

If it is necessary to provide a further breakdown of the lot, the appropriate TEI is Batch Item Identification (BII) (see B.4), which shall only be used as optional data and only in conjunction with the primary lot identification.

6 Conformance Class 2

6.1 Purpose

Conformance Class 2 allows for the use of a more flexible range of Product/Part Identifiers than the precisely defined standardized data elements in Conformance Class 1, and is intended for use by trading partners who have Product/Part Identifiers already in place; for example, aircraft or ship hull number for which a business case cannot be made to change to the specific identification requirements of Conformance Class 1. Trading partners shall agree on the Product/Part Identifiers to be used and may agree on adding additional data elements.

6.2 Detailed requirements

Conformance Class 2 follows similar overall principles to Conformance Class 1 in requiring an Enterprise Identifier and primary and secondary Product/Part Identifiers. Table 2 sets out examples of the data elements that may be represented, but is not an exhaustive list as trading partners shall agree on the data elements to be included.

Table 2 — Conformance Class 2

Essential data		
Data element type	Data element examples	Data qualifier/acceptable values
Enterprise Identifier ^{a, b}	CAGE/NCAGE DUNS EAN/UCC	CAG, 5 characters, alphanumeric DUN, 9 characters, numeric EUC, 6 to 13 characters, numeric
Primary Product/Part Identifier ^{a, b}	Serial Number, Tail Number, Hull Number, Vehicle Identification Number (VIN), Lot Number	^c
Secondary Product/Part Identifier ^b	Part Number, Model Number, Block Number, Batch Number, Registration Number	^c
Optional data		
Traceability element(s)	To be determined by trading partners	^c
^a Permanent identification is the combination of Enterprise Identifier and Primary Product/Part Identifier. ^b Trading partners shall select the data element they desire to use. ^c Data element selection sequence precedence shall be as follows. — First, as identified and defined in this International Standard. — Second, as identified and defined in the Air Transport Association (ATA) Common Support Data Dictionary (CSDD). For a listing of additional data elements, contact ATA at the following address: Air Transport Association of America SPEC 2000 Program 1301 Pennsylvania Ave. N.W. Washington, D.C. 20004-1707 USA Phone: +1 202 626 4039 Fax: +1 202 626 4081		

6.3 Recommended process

When trading partners establish a product/part identification system based on Conformance Class 2, the procedures used with Conformance Class 1, defined in 5.2.1 to 5.2.3, shall be followed.

7 Data formats

7.1 General

Data elements are identified by means of a data qualifier prefixed to the data content. They take the form of a sequence of up to four characters, depending on the data qualifier system used, directly prefixed to the data content in question. The acceptable data qualifiers are defined in 7.2, 7.3, and 7.4.

ISO/IEC 15434 defines the message structure and syntax for compliant messages transferring information from a high-capacity ADC media such as two-dimensional symbols, and defines a number of formats as the structure for representing data using specified qualifier schemes in such media. ISO/IEC 15434 is the recommended data syntax for use with this International Standard when matrix symbols are used, either on the product/part itself, or a label, or on the cover of an RFID tag. Data to be encoded in an RFID tag is formatted according to the XML syntax as defined in the W3C specification *Extensible Markup Language (XML)* and illustrated in 8.6.3.

At the time of preparation of this International Standard, there were two semantic systems listed in ISO/IEC 15434 which were being used for product identification: EAN.UCC Application Identifiers (AI) and FACT Data Identifiers (DI). EAN.UCC AI and ASC MH10 DI are identified in ISO/IEC 15418, and detailed definitions of them are given in the standards referenced in ISO/IEC 15418, namely the *General EAN.UCC Specifications* for AI and ANS MH10.8.2 for DI. For trading partners who desire to use these identification schemes described in ISO/IEC 15434, Annexes D and E specify AI and DI approximate equivalents to the recommended TEIs. See also 7.3 and 7.4.

7.2 Text Element Identifiers

TEIs are the preferred form of data qualifiers and are defined in the *ATA Common Support Data Dictionary (CSDD)*. They are a four-character string, consisting of three upper-case letters followed by a space, which is prefixed to the data content in question. When represented in machine-readable form all four characters shall be encoded, and when shown in human-readable form all four characters shall be shown. Annexes A and B provide details of the TEIs most commonly used in conjunction with this International Standard.

When data is encoded in a matrix symbol, this International Standard recommends the use of ISO/IEC 15434 syntax. If multiple data elements are concatenated into a single data element, there is no explicit data element delimiter.

When data is encoded in a linear bar code, a separate symbol shall be used for each data element.

At the time of preparation of this International Standard, ISO/IEC 15434 was under revision to provide Format Indicator 12 to represent data using TEIs. Until publication of a revised version of ISO/IEC 15434, the U.S. Department of Defense recommends the use of Format Identifier DD with ISO/IEC 15434 syntax when representing this data in matrix symbols. See Annex F for an example.

However, as a transitional provision, the forward oblique stroke, /, is recognized and may be used (without the ISO/IEC 15434 syntax) as a delimiter between elements until five years from the date of publication of this International Standard. If the product/part has been marked with a '/' prior to or during the transitional period, the matrix symbol need not be changed to the ISO/IEC 15434 syntax. After the TEI Format Indicator has been approved in ISO/IEC 15434, users should transfer to the ISO/IEC 15434 syntax as soon as feasible. Annex F gives examples of encoding data using TEIs and following both methods.

7.3 EAN.UCC Application Identifiers

EAN.UCC ¹⁾ Application Identifiers may be used with trading partner agreement. EAN.UCC Application Identifiers are identified in ISO/IEC 15418 and fully defined, with their data element characteristics, in the *General EAN.UCC Specifications*. They take the form of a numeric sequence of two to four digits directly prefixed to the data content in question.

ISO/IEC 15434 defines Format 05 as the structure for representing data using EAN.UCC Application Identifiers in high-capacity media.

When represented in a linear bar code symbol, the data shall be encoded in the UCC/EAN-128 version of Code 128, as specified in the *General EAN.UCC Specifications* and ISO/IEC 15417.

When data is encoded in a matrix symbol, the ISO/IEC 15434 syntax shall be used, and if multiple data elements are concatenated the data element delimiter shall be the G_S character (byte value 29).

1) EAN International changed its name to GS1 in 2005.

When multiple data elements are concatenated in an UCC/EAN-128 bar code symbol, the rules for the sequence of elements and the use of the FNC1 character as a delimiter defined in the *General EAN.UCC Specifications* shall be followed.

NOTE There are some TEIs for which there is no corresponding Application Identifier, and the precise definition of other Application Identifiers may differ from that of the approximately corresponding TEI. Annex D provides approximate equivalencies for certain Application Identifiers.

7.4 ASC MH10 Data Identifiers

ASC MH10 Data Identifiers may be used with trading partner agreement. ASC MH10 Data Identifiers are identified in ISO/IEC 15418 and fully defined in ANS MH10.8.2. They take the form of either a single upper-case alphabetic character, or from one to three digits followed by a single upper-case alphabetic character, directly prefixed to the data content in question.

ISO/IEC 15434 defines Format 06 as the structure for representing Data Identifiers in high-capacity media.

When multiple data elements are concatenated in a matrix symbol, the ISO/IEC 15434 syntax shall be used, and the data element delimiter shall be the G_S character (byte value 29). Multiple data elements shall not be concatenated in a linear symbol, but each data element shall be encoded in a separate symbol.

NOTE 1 It is technically possible to encode multiple data elements of this nature in a UCC/EAN128 symbol, following the EAN.UCC Application Identifier rules referred to in 7.3, by prefixing each ASC MH10 Data Identifier with Application Identifier 90. This usage is not however widely supported and is inefficient in its encoding; it is therefore not recommended.

NOTE 2 There are some TEIs for which there is no corresponding Data Identifier, and the precise definition of other Data Identifiers may differ from that of the approximately corresponding TEI. Annex E provides approximate equivalencies for certain Data Identifiers.

8 Product/part marking

8.1 Direct

For items which are marked directly on the part, matrix symbology shall be used. A matrix symbol can be readily marked on different substrates using various processes: dot peen, laser etch, electro-chemical etching, ink jet, laser bonding, etc. The combination of process methodology and substrate shall not degrade the performance of the product/part and suit its functionality in the environments in which it is required to operate over its life cycle. Subject to technical constraints, the method of direct product/part marking shall be selected to last the life of the product/part. The decision regarding the process to use and location of the symbol(s) shall be made by the responsible design or in-service engineer. ISO/IEC TR 24720 gives guidance on the selection of the direct part marking technique to be used, and SAE AS9132 and ISO/IEC TR 24720 define requirements and recommendations to maximize the quality of the resulting symbol.

8.2 Label or nameplate

Where the identification is carried on a label or nameplate, the symbology used may be any symbol specified in 8.3. The choice of the symbology or symbologies acceptable shall be defined by the trading partners concerned, subject to the constraints on data content of the linear symbologies.

8.3 Marking symbology

8.3.1 Matrix symbol

When Data Matrix is selected as the symbology, ECC200 as specified in ISO/IEC 16022 shall be used. When QR Code is selected as the symbology, Model 2 as specified in ISO/IEC 18004 shall be used. Trading partners should determine if Data Matrix or QR Code will be used. If no agreement is in place, Data Matrix shall be the default.

The preferred/default data element structure is TEIs and their corresponding data content, using either the ISO/IEC 15434 syntax or, transitionally (see 7.2), the ISO/TS 21849 syntax with the '/' separator. EAN.UCC Application Identifiers or ASC MH 10 Data Identifiers may be used with trading partner agreement. When required by agreement with trading partners (see 8.5), human translation text shall be provided adjacent to the symbol.

Annex F gives examples of the encoding of typical data elements.

8.3.2 Linear bar code

The symbology should be Code 128 as specified in ISO/IEC 15417. Trading partners may agree to use Code 39 as specified in ISO/IEC 16388. If no agreement is in place, Code 128 shall be the default.

Individual data elements shall be encoded in separate linear bar codes, each with a data qualifier and its corresponding data content. When required (see 8.5), human translation text shall be provided either above or below the linear bar code symbol. TEIs are the preferred/default semantics system to be used. EAN.UCC Application Identifiers or ASC MH 10 Data Identifiers may be used with trading partner agreement.

When trading partners agree to use the EAN.UCC Application Identifier scheme (see 7.3) in linear bar code symbols, the UCC/EAN-128 version of Code 128 shall be used in accordance with the rules of the *General EAN.UCC Specifications*.

8.4 Marking layout

8.4.1 Permanent identification

To provide permanent product/part identification, the first and second elements listed under 'Essential data' in Tables 1 and 2 shall be encoded in the same matrix symbol (i.e. the Enterprise Identifier together with the Unique Product/Part Serial Number or the Unique Component Identification Number or the Enterprise Lot Number).

In the case of linear bar coding, the first and second elements listed under 'Essential data' in Tables 1 and 2 shall be placed in separate linear bar codes on the same label or nameplate. See Figures 2 a) and 3 a) for examples.

No other data elements shall be included in the permanent identification matrix symbol or on the linear bar code label/nameplate which contains the permanent identification data elements.

8.4.2 Product/Part Identifier

The Product/Part Identifier (part number) shall be on a separate label or nameplate for linear bar coding or shall be contained in a separate matrix symbol for matrix symbol marking.

8.4.3 Matrix symbol spacing

The adjacent edges of matrix symbols shall be a minimum of 0,318 mm apart and should be at least 0,635 mm apart.

8.4.4 Examples

See Figures 2 and 3 for examples of matrix symbol and linear bar code layout.

8.5 Human translation

When an industry or trading partners agree that a human translation is required along with the matrix symbol, the text shall meet the following requirements:

- The text shall be clear enough for an individual to grasp its meaning without the use of interpretative devices or lookup tables.
- The text shall be located adjacent to the matrix symbol, with the content (data qualifier and corresponding data content) for each data element for which human translation is required contained on a separate line.
- Any encoded data delimiter used to separate data elements shall be removed from the human translation text.
- A single space shall be located between the data qualifier and the data content characters to improve human readability. For TEIs the space already forms part of the TEI data qualifier structure, therefore no additional space is added. If AI or DI data qualifiers are used, a space shall be added between the data qualifier and the data content.

NOTE 1 Spaces added to the human translation are not encoded in the machine-readable symbol.

NOTE 2 AIs may alternatively be shown in the human translation with the AI enclosed in parentheses, as specified in the *General EAN.UCC Specifications*.

Figure 4 gives a human translation example.

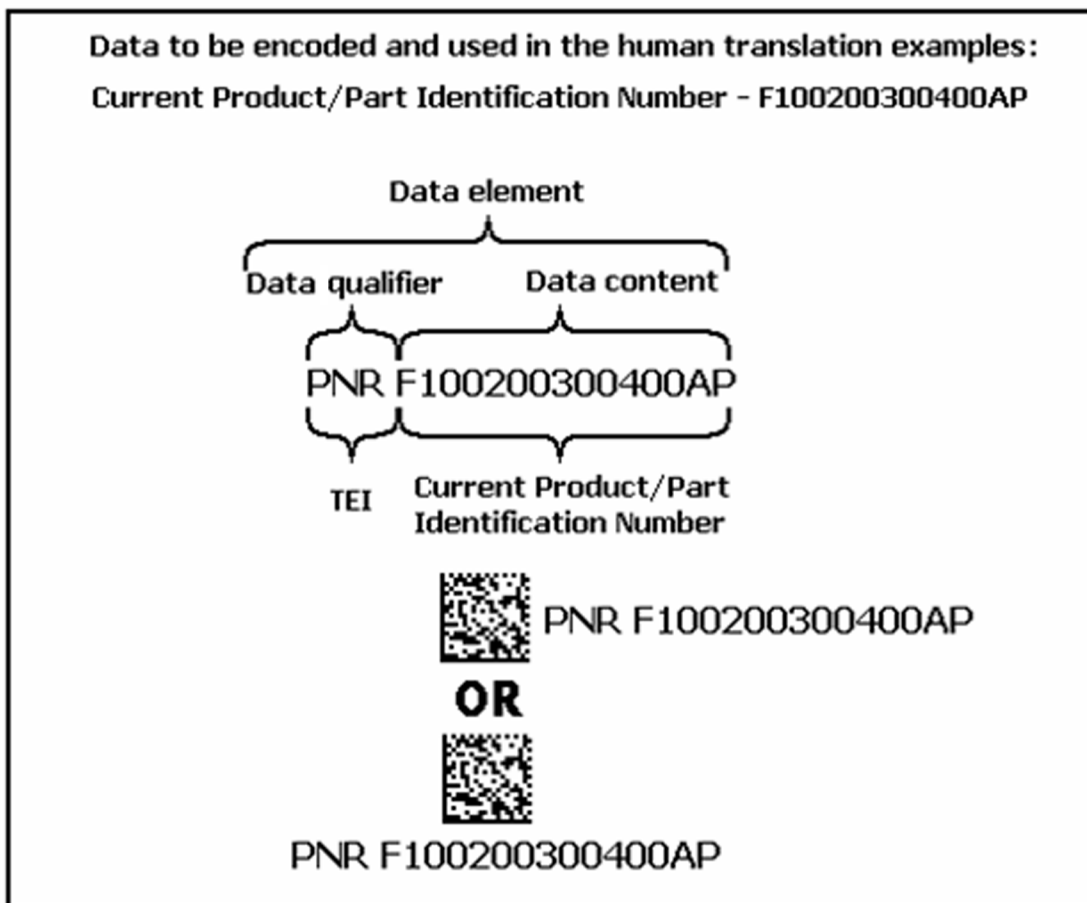

Figure 4 — Human translation example

8.6 Extended data content

8.6.1 General

Emerging technologies, such as RFID, provide features that allow new operational processes to be implemented. Key features of the emerging technologies include the following:

- the quantity of data that can be contained in the device provides an abbreviated data base;
- it is possible to separate the data into static (permanent) and dynamic (updatable) data.

However, the affixing of a new technology does not obviate the necessity to provide an optically readable Data Matrix and visually readable human translation markings (see Figures 2 b), 3 b) and I.7).

The abbreviated data base capability allows product/part traceability data to be stored in addition to essential identification and configuration data. Storing traceability data allows maintenance personnel to install a part without connection to an authoritative source of data. Business processes shall be established to ensure validation of the data with an authoritative source of data before the mechanic is issued the part.

8.6.2 Data content

8.6.2.1 Static data

Static data shall never be changed during the life cycle of the product/part. The static data elements are

- a) Enterprise Identifier (CAG, DUN, EUC);
- b) Unique Product/Part Serial Number (SER);
- c) Original Product/Part Identification Number (PNO);
- d) Manufacture Date (DMF) [Conditional, per trading partner agreement].

See Annexes A and B for detailed specifications of TEIs.

8.6.2.2 Dynamic data

Dynamic data elements may be updated. Updating shall only be accomplished by an authorized source. The dynamic data elements are

- a) Current Product/Part Identification Number (PNR);
- b) Condition Code — Product or Part (CND);
- c) Traceability data elements [Conditional, per trading partner agreement].

8.6.3 Example of a data structure using XML

```
<StaticData>
  <CAG>F9111</CAG>
  <SER>DERXY1234567890</SER>
  <PNO>FF1234567890</PNO>
  <DMF>2004-11-28</DMF>
</StaticData>
<DynamicData>
  <PNR>FF1234567890-01</PNR>
  <CND>SER</CND>
  <WEX>20000 HOUR</WEX>
  <SRI>2500 HOUR</SRI>
</DynamicData>
```

NOTE See Annex A or B for description of the XML Start-Tag and End-Tag Names.

8.7 Limited marking space procedure

Where limited space prevents the full recommended marking being applied to the product/part, the procedure in this subclause ensures that the most critical information can be fitted into the available space. The sequential list below starts with the minimum information needed for product/part identification and traceability. The list is additive from top to bottom. As many of the items, in order of priority, as space permits shall be included.

- a) Minimum information shall be the two permanent identification elements identified in Figure 1 in a single matrix symbol. Before using only the permanent identification matrix symbol, trading partners shall agree that available space can only accommodate one matrix symbol.
- b) Add the Current Product/Part Identifier in a separate matrix symbol.
- c) Add human translation:
 - 1) start with Current Product/Part Identification Number;
 - 2) add Unique Product/Part Serial Number;
 - 3) add Enterprise Identifier.

When available marking space is limited, trading partners shall determine how many human text elements to eliminate.

- d) Add linear bar code(s) in accordance with trading partner agreement:
 - 1) start with Current Product/Part Identification Number;
 - 2) add Unique Product/Part Serial Number;
 - 3) add Enterprise Identifier.

NOTE When a linear bar code is added, the human translation is part of the linear bar code.

8.8 General requirements for permanent product/part identification

To enable the machine-readable data to be properly identified, a data qualifier shall immediately precede the associated data content and be a part of the machine-readable code in both the matrix symbol and linear bar code.

When data is shared between trading partners, a data qualifier shall immediately precede the associated data content.

If the data to be encoded is less than the maximum field length, filler characters shall not be added to bring the field to its maximum length. Only actual data characters shall be encoded.

It is the responsibility of the receiving system to be able to accommodate the maximum field length within the receiving system.

Alpha, numeric and punctuation (special characters) shall be those identified in ISO/IEC 646.

If there is a discrepancy between the data resulting from a machine-readable symbol and its human-readable translation, the human-readable text shall be controlling. The human-readable text is not intended to be machine readable. In order to minimize the risk of discrepancies between machine-readable data and the human translation interpolation, both representations should be derived from a single data input.

In addition to the essential data contained in Tables 1 and 2, a non-permanent identification label or nameplate may contain information such as company logos and free-form text descriptions of the part.

The size of the label, nameplate or matrix symbol depends on available space and technical constraints.

Subject to technical constraints, the durability of the coded data on the label, nameplate or matrix symbol shall be sufficient for the data to be readable for the expected life of the part.

8.9 Detailed requirements for symbols

8.9.1 Dimensional parameters

8.9.1.1 Linear bar code

- Code 128: X dimension shall be between 0,200 mm and 0,510 mm (8 mil and 20 mil approx.)
- Code 39: X dimension shall be between 0,200 mm and 0,510 mm (8 mil and 20 mil approx.) with a minimum wide:narrow ratio of 2,5:1, preferred wide:narrow ratio of 3,0:1

NOTE For improved readability, increase the X dimension of the symbol, space permitting, and/or take other steps to improve symbol quality.

8.9.1.2 Linear bar code symbol height

For Code 128 and Code 39, the height of the bars in the bar code symbol itself should be a minimum of 3,2 mm (0,125 in).

8.9.1.3 Matrix symbol

Cell size shall be no smaller than defined in SAE AS9132.

8.9.1.4 Human translation

For both linear bar code and matrix symbols, the font height shall be a minimum of 3,2 mm (0,125 in).

Linear bar codes shall have the human translation text placed directly above or below the symbol.

Matrix symbols shall have the human translation text placed either adjacent to or below the symbol, with each data element shown on a separate line. See Figures 2 b), 3 b) and 4.

8.9.2 Symbol conformance

8.9.2.1 Durability

Subject to technical constraints, the durability of the symbol and human translation text should be sufficient for them to remain readable for the expected life of the product.

8.9.2.2 Quality level

8.9.2.2.1 Matrix symbol

8.9.2.2.1.1 Direct marked symbols

ISO/IEC 15415 will be updated to include a new clause for measuring the quality of matrix symbols directly marked on a product/part. When available, the new clause should be used to measure the quality of matrix symbols directly marked on a chart.

Annex J outlines an approach which can be used to measure the quality of a matrix symbol directly marked on a part.

8.9.2.2.1.2 Printed symbols

When measured according to ISO/IEC 15415, matrix symbols shall achieve a minimum overall symbol grade of 2,5/04/W/45 when new and 1,5/04/W/45 for the life of the product/part, where

- 2,5 is the mean of the individual grades for five scans of the symbol, rotated through 72° between scans (corresponding to an overall grade of B);
- 1,5 is the mean of the individual grades for five scans of the symbol, rotated through 72° between scans (corresponding to an overall grade of C);
- 04 [i.e. a 0,100 mm (4 mil) aperture] is the aperture reference number appropriate to a module size range from 0,125 mm (5 mil) (the minimum permitted under this International Standard);
- W indicates that a broad-band (white light) light source has been used for measurement (the spectral distribution of which should match that expected to be used for reading the symbols);
- 45 indicates that the angle of incidence of the light is 45°.

8.9.2.2.2 Linear bar code symbols

When measured according to ISO/IEC 15416, Code 39 and Code 128 symbols shall achieve a minimum overall symbol grade of 2,5/06/660 when new and 1,5/06/660 for the life of the product/part, where

- 2,5 is the mean of the individual grades for ten scans of the symbol (corresponding to an overall grade of B);
- 1,5 is the mean of the individual grades for ten scans of the symbol (corresponding to an overall grade of C);
- 06 is the aperture reference number [corresponding to a 0,200 mm (8 mil) symbol element size];
- (660 ± 10) nm is the recommended wavelength for measurement of linear symbol print quality (matching that expected to be used for reading the symbols).

NOTE 660 nm is typical of many laser diode and red LED light sources.

Annex A (normative)

Data dictionary: Essential data elements

Data definitions contained in this annex are the primary TEIs needed to support the product/part identification schema defined in this International Standard.

A.1 CAGE/NCAGE Code

NAME: CAGE/NCAGE Code		
TEI: CAG		
Definition: A unique five-character identification for an enterprise or an identifiable portion of an enterprise.		
Class: AN		
Decimals:		
Min_Length: 5		
Max_Length: 5		
Case sensitive: Yes		
Business rules		
<ol style="list-style-type: none"> 1) Alpha characters shall be upper case. 2) Use the five position alphanumeric codes specified in Cataloging Handbook H4/H8: Sections A and B, Commercial and Government Entity (CAGE) Codes (United States and Canada only) and Sections C and D, NATO Supply Codes for Manufacturers (NSCM) (excluding United States and Canada). 3) CAG is the TEI for the enterprise assigning a Unique Product/Part Serial Number (SER) or a Unique Component Identification Number (UCN). The owner of the CAGE/NCAGE Code assigns the Unique Product/Part Serial Number or Unique Component Identification Number which is unique within the CAGE/NCAGE Code. 4) Unique Product/Part Serial Number (SER) shall only be assigned by the original manufacturer of the product/part. 5) Unique Component Identification Number (UCN) shall be assigned when the organization is any other than the original manufacturer. 		
Remarks		
<ol style="list-style-type: none"> 1) ISO/TS 21849 used MFR to identify the product/part designer/manufacturer. MFR shall be considered equal to CAG. As business conditions permit, MFR should be phased out in favour of CAG for the Enterprise Identifier of the product/part manufacturer. 2) ISO/TS 21849 used SPL to identify the owner of an in-service part when assigning a UCN. SPL shall be considered equal to CAG. As business conditions permit, SPL should be phased out in favour of CAG. 3) US Companies CAGE code information at URL: http://www.ccr.gov or call for assistance at 1-888-227-2423. 4) Non-US companies CAGE code information at URL: http://www.ccr.gov. 		

A.2 Current Product/Part Identification Number

NAME: Current Product/Part Identification Number		
Tag: PNR		
Definition: The design activity or industry standard identity for the subject part, assembly, kit or material item. It is used to identify a given configuration that is interchangeable. The Current Product/Part Identification Number is unique within a business entity.		
Class: AN Decimals: Min_Length: 1 Max_Length: 15 Case sensitive: Yes		
Business rules <ol style="list-style-type: none"> 1) All products/parts of the same configuration (form, fit, and function) shall have the same product/part identification number. 2) Alpha characters shall be upper case. 3) The hyphen (-) is the only special character permitted in the Current Product/Part Identification Number. However, the hyphen (-) is not allowed as the first or last character of a Current Product/Part Identification Number. 4) Current Product/Part Identification Numbers are controlled by the cognizant design authority. Normally this is Engineering. 5) For a part defined in an international/national standard, the part number is assigned by the organization controlling the standard. 		
Remarks For life cycle product/part management, the data base should contain the identity of the company/organization that is the cognizant design activity. See Action Code data definition in B.1 for the method to record designer.		

A.3 D&B D-U-N-S®²⁾ Number

NAME: D&B D-U-N-S® Number		
TEI: DUN		
Definition: A nine-numeric-character identification sequence which provides a unique ID for business entities while linking corporate family structures together.		
Class:	N	
Decimals:		
Min_Length:	9	
Max_Length:	9	
Case sensitive:	No	
Business rules		
<ol style="list-style-type: none"> 1) Data content shall be the nine numeric characters of the D-U-N-S® number. 2) DUN is the TEI for the enterprise assigning Unique Product/Part Serial Number (SER) or a Unique Component Identification Number (UCN). The owner of the D-U-N-S® Code assigns the Unique Product/Part Serial Number or Unique Component Identification Number which is unique within the D-U-N-S® Code. 3) Unique Product/Part Serial Number (SER) shall only be assigned by the original manufacturer of the product/part. 4) Unique Component Identification Number (UCN) shall be assigned when the organization is any other than the original manufacturer. 		
Remarks		
<ol style="list-style-type: none"> 1) The hyphen in the D&B D-U-N-S® number shall be dropped, leaving only the nine numeric characters. 2) For assignment of a number and details on the D&B D-U-N-S® Number, see URL http://www.dnb.com/ 		

2) D-U-N-S is the trade name of a numbering system supplied by Dun and Bradstreet. This information is given for the convenience of users of this International Standard and does not constitute an endorsement by ISO of the product named.

A.4 EAN.UCC Company Identifier

NAME: EAN.UCC Company Identifier			
TEI: EUC			
Definition: A unique numeric identification for an enterprise or an identifiable portion of an enterprise.			
Class: N			
Decimals:			
Min_Length: 6			
Max_Length: 13			
Case sensitive: No			
Business rules			
<ol style="list-style-type: none"> 1) Data content shall be the EAN.UCC assigned 6 to 13 digit company identifier. 2) EUC is the TEI for the enterprise assigning Unique Product/Part Serial Number (SER) or a Unique Component Identification Number (UCN). The owner of the Company Identifier Code assigns the Unique Product/Part Serial Number or Unique Component Identification Number which is unique within the Company Identifier Code. 3) Unique Product/Part Serial Number (SER) shall only be assigned by the original manufacturer of the product/part. 4) Unique Component Identification Number (UCN) shall be assigned when the organization is any other than the original manufacturer. 			
Remarks			
For assignment of a company identifier and details on the data structure, contact EAN International in Brussels, Belgium or the appropriate EAN International national body member.			

A.5 Enterprise Lot Number

NAME: Enterprise Lot Number		
TEI: LTN		
<p>Definition: The original manufacturer's unique identity for a group of units of the same item which are processed, manufactured or assembled by one producer under uniform conditions, and which are expected to function in a uniform manner. Enterprise Lot Number, when linked with the Enterprise Identifier, provides the permanent identification for a given group of like items. The Enterprise Lot Number is unique within the Enterprise Identifier.</p>		
<p>Class: AN</p> <p>Decimals</p> <p>Min_Length: 1</p> <p>Max_Length: 15</p> <p>Case sensitive: Yes</p>		
<p>Business rules</p> <ol style="list-style-type: none"> 1) Alpha characters shall be upper case. 2) The hyphen (-) is the only special character permitted in the Enterprise Lot Number. However, the hyphen (-) is not allowed as the first or last position of a Lot Number. 		
<p>Remarks</p> <ol style="list-style-type: none"> 1) When used as part of the permanent identification, LTN shall be used in lieu of SER. 2) To subdivide a lot, use Batch Item Identifier (BII). 3) Lot is being used as the prime identifier because of common usage. 4) LTN shall only be used in conjunction with the product/part identification scheme defined in Conformance Classes 1 and 2 in Clauses 5 and 6, respectively. It shall not be used in conjunction with the legacy part identification schema described in Annex G. 		

A.6 Unique Component Identification Number

NAME: Unique Component Identification Number		
TEI: UCN		
Definition: Used in lieu of the Unique Product/Part Serial Number (SER) when the serial number assigned to a product/part is accomplished by an organization other than the original manufacturer. The Unique Component Identification Number is unique within the Enterprise Identifier.		
Class: AN		
Decimals:		
Min_Length: 1		
Max_Length: 15		
Case sensitive: Yes		
Business rules		
<ol style="list-style-type: none"> 1) Alpha characters shall be upper case. 2) The hyphen (-) is the only special character permitted in the Unique Component Identification Number field. However, the hyphen (-) is not allowed as the first or last character of the UCN. 		
Remarks		
See the CAGE/NCAGE Code, D&B D-U-N-S Number or EAN.UCC Company Identifier data definitions for the rules on the proper use of this TEI.		

A.7 Unique Product/Part Serial Number

NAME: Unique Product/Part Serial Number		
TEI: SER		
<p>Definition: The original manufacturer's unique identity for an individual part, assembly, kit or materiel item. Unique Product/Part Serial Number, when linked with the appropriate Enterprise Identifier, provides the permanent identification for a given item. The Unique Product/Part Serial Number is unique within the Enterprise Identifier.</p>		
<p>Class: AN</p> <p>Decimals:</p> <p>Min_Length: 1</p> <p>Max_Length: 15</p> <p>Case sensitive: Yes</p>		
<p>Business rules</p> <ol style="list-style-type: none"> 1) Alpha characters shall be upper case. 2) The hyphen (-) is the only special character permitted in the Product/Part Serial Number. However, the hyphen (-) is not allowed as the first or last character of a Product/Part Serial Number. 		
<p>Remarks</p> <ol style="list-style-type: none"> 1) Only the original manufacturer of the product/part shall use SER. 2) See the CAGE/NCAGE Code, D&B D-U-N-S® Number or EAN.UCC Company Identifier data definitions for the rules on the proper use of this TEI. 		

A.8 Universal Serial Number

NAME: Universal Serial Number		
TEI: USN		
Definition: Element which combines the data content of a CAGE/NCAGE Code Enterprise Identifier and Unique Product/Part Serial Number under a single TEI.		
Class: AN		
Decimals:		
Min_Length: 6		
Max_Length: 20		
Case sensitive: Yes		
Business rules		
<ol style="list-style-type: none"> 1) Data format is AN₅AN₁₋₁₅. 2) Data content is CAGE/NCAGE Code, Unique Product/Part Serial Number. 3) The first five characters are the CAGE/NCAGE Code data content characters for the original manufacturer of the product/part. 4) The second set of 1 to 15 characters are the Unique Product/Part Serial Number data content characters assigned by the enterprise owning the CAGE/NCAGE being used. 5) There is no space between the Enterprise Identifier data content characters and the following Unique Product/Part Serial Number data content characters. 6) Alpha characters shall be upper case. 		
Remarks		
<ol style="list-style-type: none"> 1) Only the original manufacturer of the product/part shall use USN. 2) Refer to CAGE/NCAGE Code and Unique Product/Part Serial Number data definitions for structure. 		
Uses		
<ol style="list-style-type: none"> 1) This element shall be used when space does not permit using the CAG and SER data elements separately to permanently identify a product or part. 2) It may also be used by a company to provide a standardized permanent identification for both large and small size parts. 		

A.9 Universal Serial Tracking Number

NAME: Universal Serial Tracking Number		
TEI: UST		
Definition: Element which combines the data content of a CAGE/NCAGE Code Enterprise Identifier and Unique Component Identification Number under a single TEI.		
Class: AN		
Decimals:		
Min_Length: 6		
Max_Length: 20		
Case sensitive: Yes		
Business rules		
<ol style="list-style-type: none"> 1) Data format is AN₅AN₁₋₁₅. 2) Data content is CAGE/NCAGE Code, Unique Component Identification Number. 3) The first five characters are the CAGE/NCAGE Code data content characters for the enterprise assigning the Unique Component Identification Number. 4) The second set of 1 to 15 characters are the Unique Component Identification Number data content characters assigned by the enterprise owning the CAGE/NCAGE being used. 5) There is no space between the Enterprise Identifier data content characters and the following Unique Component Identification Number data content characters. 6) Alpha characters shall be upper case. 		
Remarks		
<ol style="list-style-type: none"> 1) UST shall be used when retroactively identifying an in-service product/part or when the product/part is being identified by an enterprise other than the original manufacture. 2) Refer to CAGE/NCAGE Code and Unique Component Identification Number data definitions for structure. 		
Uses		
This element shall be used when space does not permit using the CAG and UCN data elements separately to permanently identify a product or part.		

Annex B (normative)

Data dictionary: Optional/other data elements

Data definitions contained in this annex are included to support

- in-service parts which were identified in accordance with ISO/TS 21849;
- a legacy part identification schema described in Annex G;
- license plate structure as defined in ISO/IEC 15459;
- product/part traceability;
- ISO 10303-239.

B.1 Action Code

NAME: Action Code																																								
TEI: ACT																																								
Definition: A list of action taken codes to describe at high level what action was taken. These codes report the action taken on a product, part or lot as it moves through its life cycle process.																																								
Class: AN																																								
Decimals:																																								
Min_Length: 5																																								
Max_Length: 34																																								
Case sensitive: No																																								
Business rules																																								
<ol style="list-style-type: none"> 1) Data format is A₃-AN₁ ... AN₃₀. 2) Data content is action taken code, hyphen, action description. 																																								
<table border="0"> <thead> <tr> <th style="text-align: left;"><u>Action taken code</u></th> <th style="text-align: left;"><u>Action description (question to be answered for AN₁ to AN₃₀)</u></th> </tr> </thead> <tbody> <tr> <td>BUY-</td> <td>Bought from</td> </tr> <tr> <td>CDO-</td> <td>Current design activity/organization</td> </tr> <tr> <td>DES-</td> <td>How destroyed</td> </tr> <tr> <td>EXC-</td> <td>Exchanged for/with</td> </tr> <tr> <td>INP-</td> <td>Inspected what, tested what, adjusted what</td> </tr> <tr> <td>INS-</td> <td>Installed on/in (vehicle or assembly)</td> </tr> <tr> <td>MFG-</td> <td>Manufactured by</td> </tr> <tr> <td>MKR-</td> <td>Marked by</td> </tr> <tr> <td>ODO-</td> <td>Original design activity/organization</td> </tr> <tr> <td>OTH-</td> <td>Freelance note</td> </tr> <tr> <td>OVH-</td> <td>How overhauled/remanufactured and/or new limits if applicable (calendar date, hours, cycles, etc.)</td> </tr> <tr> <td>RCD-</td> <td>Received from</td> </tr> <tr> <td>RMV-</td> <td>Removed from (vehicle or assembly)</td> </tr> <tr> <td>RPR-</td> <td>Repaired by</td> </tr> <tr> <td>SHP-</td> <td>Shipped to (inside or outside of a company)</td> </tr> <tr> <td>SLD-</td> <td>Sold to</td> </tr> <tr> <td>UPG-</td> <td>Upgraded, new part number is</td> </tr> <tr> <td>WHR-</td> <td>Warehoused at</td> </tr> </tbody> </table>			<u>Action taken code</u>	<u>Action description (question to be answered for AN₁ to AN₃₀)</u>	BUY-	Bought from	CDO-	Current design activity/organization	DES-	How destroyed	EXC-	Exchanged for/with	INP-	Inspected what, tested what, adjusted what	INS-	Installed on/in (vehicle or assembly)	MFG-	Manufactured by	MKR-	Marked by	ODO-	Original design activity/organization	OTH-	Freelance note	OVH-	How overhauled/remanufactured and/or new limits if applicable (calendar date, hours, cycles, etc.)	RCD-	Received from	RMV-	Removed from (vehicle or assembly)	RPR-	Repaired by	SHP-	Shipped to (inside or outside of a company)	SLD-	Sold to	UPG-	Upgraded, new part number is	WHR-	Warehoused at
<u>Action taken code</u>	<u>Action description (question to be answered for AN₁ to AN₃₀)</u>																																							
BUY-	Bought from																																							
CDO-	Current design activity/organization																																							
DES-	How destroyed																																							
EXC-	Exchanged for/with																																							
INP-	Inspected what, tested what, adjusted what																																							
INS-	Installed on/in (vehicle or assembly)																																							
MFG-	Manufactured by																																							
MKR-	Marked by																																							
ODO-	Original design activity/organization																																							
OTH-	Freelance note																																							
OVH-	How overhauled/remanufactured and/or new limits if applicable (calendar date, hours, cycles, etc.)																																							
RCD-	Received from																																							
RMV-	Removed from (vehicle or assembly)																																							
RPR-	Repaired by																																							
SHP-	Shipped to (inside or outside of a company)																																							
SLD-	Sold to																																							
UPG-	Upgraded, new part number is																																							
WHR-	Warehoused at																																							
Remarks																																								
<ol style="list-style-type: none"> 1) Action taken codes modify ACT and are the initial part of the data content. 2) A hyphen is included immediately after the three-character action taken code. 3) No space is left between the hyphen and start of the free-format text. 4) Action descriptions are free-format text. 5) Free-format text characters shall be in accordance with ISO/IEC 646. 																																								

B.2 Action Company

NAME: Action Company		
TEI: ACO		
Definition: Element used in combination with the appropriate Enterprise Identifier.		
Class: AN		
Decimals:		
Min_Length: 9		
Max_Length: 17		
Case sensitive: Yes		
Business rules		
<ol style="list-style-type: none"> 1) Data format is A₃-AN₅-AN₁₃. 2) Data content is Enterprise Identifier, hyphen, Enterprise Value. 		
Remarks		
<ol style="list-style-type: none"> 1) Allowable Enterprise Identifiers are CAG, DUN and EUC. 2) The three alpha characters of the Enterprise Identifier TEI followed immediately by a hyphen (-) will be entered as the first part of the data content. 		

B.3 Action Date

NAME: Action Date		
TEI: ACD		
Definition: The data element used to record the date on which an action was taken.		
Class: N		
Decimals:		
Min_Length: 10		
Max_Length: 16		
Case sensitive: Yes		
Business rules		
<ol style="list-style-type: none"> 1) Data format is YYYY-MM-DD. 2) Data content is year, hyphen, month, hyphen, day. 3) If hours and minutes are needed in addition to the year, month, and day, the 24-hour clock employing local time shall be used. In this case, <ul style="list-style-type: none"> — the data format is YYYY-MM-DDThh:mm; — the data content is year, hyphen, month, hyphen, day, 'T', hours, colon, minutes. 4) Alpha characters shall be upper case. 		
Remarks		
See "complete representations" in ISO 8601 for details on date structure.		

B.4 Batch Item Identifier

NAME: Batch Item Identifier		
TEI: BII		
<p>Definition: The identification number assigned to a specific quantity of products/parts which were produced during a particular production run. The Batch Item Identifier provides valuable source of traceability information about the origin of a product/part.</p>		
<p>Class: AN</p> <p>Decimals:</p> <p>Min_Length: 1</p> <p>Max_Length: 15</p> <p>Case sensitive: Yes</p>		
<p>Business rules</p> <ol style="list-style-type: none"> 1) Alpha characters shall be upper case. 2) The hyphen (-) is the only special character permitted in the Batch Item Identifier. However, the hyphen (-) is not allowed as the first or last position of a Batch Item Identifier. 		
<p>Remarks</p> <ol style="list-style-type: none"> 1) This TEI shall only be used to subdivide a lot. 2) Batch identification is optional data. Lot number is the primary traceability number in the lot, batch sequence. 		

B.5 Condition Code — Product or Part

NAME: Condition Code — Product or Part														
TEI: CND														
Definition: Element which reports the status of a product, part or lot as it moves through the life cycle process.														
Class: A														
Decimals:														
Min_Length: 3														
Max_Length: 3														
Case sensitive: Yes														
Business rules														
<ol style="list-style-type: none"> 1) Data format is A3. 2) Data content is status code. 3) There are five possible status codes: <table border="0" style="margin-left: 20px;"> <thead> <tr> <th style="text-align: left;">Code</th> <th style="text-align: left;">Meaning</th> </tr> </thead> <tbody> <tr> <td>SRV</td> <td>the part is serviceable.</td> </tr> <tr> <td>UNS</td> <td>the part is unserviceable.</td> </tr> <tr> <td>SCP</td> <td>the part has been declared scrap.</td> </tr> <tr> <td>DES</td> <td>the part has been physically destroyed</td> </tr> <tr> <td>UNK</td> <td>the condition of the part is unknown.</td> </tr> </tbody> </table> 4) The five status codes listed are the only valid data content entries for CND. 5) Codes are upper-case alpha characters. 			Code	Meaning	SRV	the part is serviceable.	UNS	the part is unserviceable.	SCP	the part has been declared scrap.	DES	the part has been physically destroyed	UNK	the condition of the part is unknown.
Code	Meaning													
SRV	the part is serviceable.													
UNS	the part is unserviceable.													
SCP	the part has been declared scrap.													
DES	the part has been physically destroyed													
UNK	the condition of the part is unknown.													
Remarks														
No data follows the status code.														

B.6 End of Useful Life Date

NAME: End of Useful Life Date		
TEI: LIF		
Definition: The calendar date when a component or part requires servicing, inspection or removal.		
Class: AN		
Decimals:		
Min_Length: 10		
Max_Length: 10		
Case sensitive: No		
Business rules		
<ul style="list-style-type: none"> 1) Date format is YYYY-MM-DD. 2) Data content is year, hyphen, month, hyphen, day. 		
Remarks		
See "complete representations" in ISO 8601 for details on date structure.		

B.7 Lot Number

NAME: Lot Number		
TEI: LOT		
<p>Definition: The original manufacturer's unique identity for a group of units of the same item which are processed, manufactured or assembled by one producer under uniform conditions, and which are expected to function in a uniform manner. Lot Number, when linked with the Enterprise Identifier and Original Product/Part Identification Number, provides the permanent identification for a given group of like items. The Lot Number is unique within the Original Product/Part Identification Number.</p>		
<p>Class: AN</p> <p>Decimals:</p> <p>Min_Length: 1</p> <p>Max_Length: 15</p> <p>Case sensitive: Yes</p>		
<p>Business rules</p> <ol style="list-style-type: none"> 1) Alpha characters shall be upper case. 2) The hyphen (-) is the only special character permitted in the Lot Number. However, the hyphen (-) may not occupy the first or last position of a Lot Number. 		
<p>Remarks</p> <ol style="list-style-type: none"> 1) When used as part of the legacy part identification schema (see Annex G) LOT is used in lieu of SEQ. 2) To subdivide a lot, use Batch Item Identifier (BII) 3) Lot is being used as the prime identifier because of common usage. 4) LOT shall not be used in conjunction with the product/part identification scheme defined in Conformance Classes 1 and 2 in Clauses 5 and 6, respectively. 		

B.8 Manufacturer Code

NAME: Manufacturer Code		
TEI: MFR		
Definition: Element which identifies the manufacturer, government agency or other organization controlling the design and the part number of the subject part.		
Class:	AN	
Decimals:		
Min_Length:	5	
Max_Length:	5	
Case sensitive:	Yes	
Business rules		
Use the five-position alphanumeric codes specified in Cataloging Handbook H4/H8: Sections A and B, Commercial and Government Entity (CAGE) Codes (United States and Canada only) and Sections C and D, NATO Supply Codes for Manufacturers (NSCM) (excluding United States and Canada).		
Remarks		
<ol style="list-style-type: none"> 1) ISO/TS 21849 used MFR to identify the product/part designer/manufacturer. As business conditions permit, MFR should be phased out in favour of CAG, the TEI for the CAGE/NCAGE Enterprise Identifier. 2) CAUTION During implementation of ATA Spec 2000 in the aviation industry, MFR has been used to identify the designer and/or the manufacturer. 		

B.9 Manufacture Date

NAME: Manufacture Date		
TEI: DMF		
<p>Definition: The date on which the subject part, assembly, or material item is first certified by the manufacturer as a serviceable item. Where the customer stipulates fitment of its own serviceable unit, the Manufacture Date will be the date of the release note, supplied with the equipment, by the customer.</p>		
<p>Class: N</p> <p>Decimals:</p> <p>Min_Length: 10</p> <p>Max_Length: 10</p> <p>Case sensitive: No</p>		
<p>Business rules</p> <ol style="list-style-type: none"> 1) Data format is YYYY-MM-DD. 2) Data content is year, hyphen, month, hyphen, day. 		
<p>Remarks</p> <p>See "complete representations" in ISO 8601 for details on date structure.</p>		

© ISO 2006. All rights reserved.

B.10 Original Product/Part Identification Number

NAME: Original Product/Part Identification Number		
Tag: PNO		
Definition: The design activity or industry standard identity for the subject part, assembly, kit or material item. It is used to identify a given configuration that is interchangeable. The Original Product/Part Identification Number is unique within a business entity.		
Class: AN Decimals: Min_Length: 1 Max_Length: 15 Case sensitive: Yes		
Business rules <ol style="list-style-type: none"> 1) All products/parts of the same configuration (form, fit and function) shall have the same Original Product/Part Identification Number. 2) Alpha characters shall be upper case. 3) The hyphen (-) is the only special character permitted in the Original Product/Part Identification Number. However, the hyphen (-) may not be the first or last character of a Original Product/Part Identification Number. 4) Original Product/Part Identification Numbers are controlled by the cognizant design authority. Normally this is Engineering. 		
Remarks <ol style="list-style-type: none"> 1) This TEI shall only be used when there is a need to maintain the Original Product/Part Identification Number on the product/part for the life cycle of the product/part. 2) For the legacy part identification schema, it is used in conjunction with the Sequential Product/Part Serial Number (SEQ) or Lot Number (LOT). 		

B.11 Overlength Part Number

NAME: Overlength Part Number		
TEI: OPN		
Definition: Element which identifies the characters for a product/part identification number exceeding 15 characters in length.		
Class: AN		
Decimals:		
Min_Length: 1		
Max_Length: 17		
Case sensitive: Yes		
Business rules		
<ol style="list-style-type: none"> 1) Alpha characters shall be upper case. 2) This data field contains characters 16 to 32 of a product/part identification number which exceeds 15 characters. 		
Remarks		
<ol style="list-style-type: none"> 1) When needed, this data element is used in conjunction with the Current or Original Product/Part Identification Number (PNR or PNO) data element. 2) Refer to Current or Original Product/Part Identification Number (PNR or PNO) for definition and structure. 3) It is the responsibility of the sending and receiving system to separate or combine Current or Original Product/Part Identification Number (PNR or PNO) and Overlength Part Number (OPN) for data encoding, data transmission and human translation text. 		

B.12 Sequential Product/Part Serial Number

NAME: Sequential Product/Part Serial Number		
TEI: SEQ		
Definition: The original manufacturer's identity for an individual part, assembly, kit or materiel item. Sequential Product/Part Serial Number shall be unique within the Original Product/Part Identification Number.		
Class: AN Decimals: Min_Length: 1 Max_Length: 15 Case sensitive: Yes		
Business rules <ol style="list-style-type: none"> 1) Alpha characters shall be upper case. 2) The hyphen (-) is the only special character permitted in the Sequential Product/Part Serial Number. However, the hyphen (-) may not occupy the first or last position of a Sequential Product/Part Serial Number. 		
Remarks This TEI shall only be used in conjunction with the Original Product/Part Identification Number (PNO).		

B.13 Service Required Interval

NAME: Service Required Interval		
TEI: SRI		
Definition: The duration, cycles or distance at which a component or part requires servicing, inspection or removal.		
Class: AN		
Decimals:		
Min_Length: 4		
Max_Length: 10		
Case sensitive: Yes		
Business rules		
<ol style="list-style-type: none"> 1) For years — should be XXXX YEARS, may be XXXXXXXX YR. 2) For months — should be XXX MONTHS, may be XXXXXXXX MH. 3) For days — should be XXXXX DAYS, may be XXXXXXXX DY. 4) For hours — should be XXXXX HOUR, may be XXXXXXXX HR. 5) For cycles — should be XXXX CYCLE, may be XXXXXXXX CZ. 6) For kilometres — shall be XXXXXXXX KM. 7) For statute miles — shall be XXXXXXXX MI. 8) For nautical miles — shall be XXXXXXXX NM. 		
Remarks		
<ol style="list-style-type: none"> 1) Duration, cycle and distance descriptors are upper-case alpha characters. 2) A space is encoded and shown in human-readable form between the numeric quantity and the alpha unit of measure. 		

B.14 Supplier Code

NAME: Supplier Code		
TEI: SPL		
Definition: Element which identifies the organization assigning a Unique Component Identification Number (UCN) to an in-service product/part, where the organization is not the original manufacturer of the product/part.		
Class: AN		
Decimals:		
Min_Length: 5		
Max_Length: 5		
Case sensitive: Yes		
Business rules Use the CAGE or NCAGE code of the organization assigning the Unique Component Identification Number (UCN).		
Remarks <ol style="list-style-type: none"> 1) Used when retroactively identifying an in-service product/part. 2) Refer to Manufacturer Code (MFR) data definition for the CAGE/NCAGE structure. 3) ISO/TS 21849 used SPL to identify the product/part owner when assigning a permanent identification for an in-service product/part. As business conditions permit, SPL should be phased out in favour of CAG, DUN or EUC as appropriate. 		

B.15 Unique Item Identification Number

NAME: Unique Item Identification Number		
TEI: UID		
Definition: Element which provides an item identification number that is unique throughout the world in an open system environment.		
Class: AN		
Decimals:		
Min_Length: 7		
Max_Length: 45		
Case sensitive: Yes		
Business rules		
<p>1) CONSTRUCT 1:</p> <ul style="list-style-type: none"> — data format is C₁.C₂E₅ ... E₁₃N₁ ... N₁₅; — data content is Issuing Agency Code (C) plus Enterprise Identifier (E) data content plus Unique Product/Part Serial Number (N) or Unique Component Identification Number (N) data content. <p>2) CONSTRUCT 2:</p> <ul style="list-style-type: none"> — data format is C₁.C₂E₅ ... E₁₃P₁ ... P₁₅S₁ ... S₁₅; — data content is Issuing Agency Code (C) plus Enterprise Identifier (E) data content plus Original Product/Part Identification Number (P) data content plus Sequential Product/Part Serial Number (S) data content. <p>3) Any hyphen (-) used in the data content of the data elements listed in 1) and 2) will be eliminated when deriving the UID number.</p> <p>4) Once the data content is established for this TEI, it shall not be parsed to determine the data elements used to construct the UID.</p> <p>5) Refer to ISO/IEC 15459-2 for the procedure to obtain the Issuing Agency Code assigned to the Enterprise Identifier being used.</p>		
Remarks		
<p>1) This identification number meets the requirements contained in ISO/IEC 15459 for a unique item identification number.</p> <p>2) The data content of this data element is intended to be used in a data base. It should not be used as a data element on a product/part.</p>		

B.16 Warranty Date

NAME: Warranty Date		
TEI: DTW		
Definition: The calendar date on which the warranty ends for a product, component or part.		
Class: AN		
Decimals:		
Min_Length: 10		
Max_Length: 10		
Case sensitive: No		
Business rules		
<ul style="list-style-type: none"> 1) Data format is YYYY-MM-DD. 2) Data content is year, hyphen, month, hyphen, day. 		
Remarks		
See "complete representations" in ISO 8601 for details on date structure.		

B.17 Warranty Expiration

NAME: Warranty Expiration		
TEI: WEX		
Definition: The duration, cycles or distance when the warranty expires.		
Class: N		
Decimals:		
Min_Length: 4		
Max_Length: 10		
Case sensitive: Yes		
Business rules		
<ol style="list-style-type: none"> 1) For years — should be XXXX YEARS, may be XXXXXXXX YR. 2) For months — should be XXX MONTHS, may be XXXXXXXX MH. 3) For days — should be XXXXX DAYS, may be XXXXXXXX DY. 4) For hours — should be XXXXX HOUR, may be XXXXXXXX HR. 5) For cycles — should be XXXX CYCLE, may be XXXXXXXX CZ. 6) For kilometres — shall be XXXXXXXX KM. 7) For statute miles — shall be XXXXXXXX MI. 8) For nautical miles — shall be XXXXXXXX NM. 		
Remarks		
<ol style="list-style-type: none"> 1) Duration, cycle and distance descriptors are upper-case alpha characters. 2) A space is encoded and shown in human-readable form between the numeric quantity and the alpha unit of measure. 		

Annex C **(informative)**

Life cycle traceability

Life cycle traceability is required to safely maximize the performance of a product or part with the minimum expenditure of resources. This is achieved by using life cycle data to help accomplish activities such as improving reliability and maintainability, and identifying fraudulent and unapproved parts.

Figure C.1 is an example of how a data file may be constructed using the TEIs listed in Annexes A and B.

Figure C.1

Enterprise Identifier (CAG) or (DUN) or (EUC)	Unique Product/Part Serial Number or Enterprise Lot Number (SER) or (LTN)	Current Product/Part Identification Number (PNR)	Condition Code — Product/Part (CND)	Action Date (ACD)	Action Company (ACO)	Action Code (ACT)	Extensibility elements ^a
Permanent identification data elements Essential identification data elements						BUY- Bought from CDO- Current design activity/organization is DES- How destroyed EXC- Exchanged for/with INP- What inspected, or tested, or adjusted INS- Installed on/in ^b MFG- Manufactured by whom MKR- Marked by ODO- Original design activity/organization was OTH- Freelance note OVH- How overhauled/remanufactured and/or new limits, if applicable ^c RCD- Received from RMV- Removed from ^b RPR- Repaired by SHP- Shipped to ^d SLD- Sold to UPG- Upgraded, new part number is WHR- Warehoused at	
		SRV					
			UNS		CAG-		
			SCP		DUN-		
			DES		EUC-		
			UNK				

- ^a Determined by an industry, trading partners or a company.
- ^b Vehicle or assembly.
- ^c Calendar date, hours, cycles, etc.
- ^d Inside or outside a company.

Figure C.1 — Example of a product/part traceability data file

Annex D (normative)

EAN.UCC Application Identifier (AI) equivalencies

D.1 Purpose

This annex describes an approach which allows selected EAN.UCC Application Identifiers (AI) to be used in lieu of Text Element Identifiers (TEI) while employing the product/part identification schema described in this International Standard. Application Identifiers are only used with trading partner agreement. See 7.3.

For detailed information on AI structure and use, see the *General EAN.UCC Specifications*.

D.2 EAN.UCC serial identification

AI 8004 (GIAI) is a combination of the EAN.UCC Company Prefix and the Individual Asset Reference number. Once combined, the number cannot be parsed into the two data elements used to construct the EAN.UCC Serial Identification Number. To breakout the Individual Asset Reference number, a software algorithm will need to be constructed which subtracts the Company Prefix provided in AI 95 from the 8004 number.

Table D.1 — EAN.UCC Application Identifier approach

Essential data		
Element	Application Identifier	Valid values/size (characters)
Enterprise Identifier^a EAN.UCC Company Prefix	95	6 to 13 characters, numeric
Unique Product/Part Serial Number^{a, b} Global Individual Asset Identifier (GIAI)	8004 ^c	1 to 30 characters, alphanumeric
Current Product/Part Identifier Global Trade Item Number (GTIN)	01	14 characters, numeric
Additional Product ^d Identification	240 ^e	1 to 30 characters, alphanumeric
Optional data		
Traceability element	To be determined by trading partners	f

^a Permanent identification is the combination of EAN.UCC Company Prefix and the Global Individual Asset Identifier (GIAI) or Batch/Lot Number within the Enterprise Identifier.

^b Unique Product/Part Serial Number or Batch/Lot Number is assigned by the original manufacturer and is unique within the Company Prefix of the manufacturer.

^c The AI 8004 identification number assigned by the original manufacturer shall stay with the product/part for its entire life cycle. It shall not be changed or removed from the product/part even if the product/part ownership changes.

^d This AI shall always be used in association with AI 01.

^e Current Product/Part Identifier (Number) is assigned by the organization responsible for configuration of the part. The responsible organization is normally Engineering. The Current Product/Part Number is a unique number assigned to one or more like units which have the same form, fit and function. The Current Product/Part Number marking should be separate from the permanent identification marking so that it can be updated over the life cycle of the part when the form, fit or function changes.

^f Traceability data element selection sequence precedence shall be

- first, use Application Identifiers as published in the *General EAN.UCC Specifications*;
- second, trading partner established using AI 90.

Annex E (normative)

ASC MH10 Data Identifier (DI) (codified in ISO/IEC 15418) equivalencies

E.1 Purpose

This annex describes an approach which allows selected ASC MH10 Data Identifiers (DI) to be used in lieu of Text Element Identifiers (TEI) while employing the product/part identification schema defined in this International Standard. DIs are only used with trading partner agreement (see 7.4).

NOTE These DIs were originally referred to as FACT Data Identifiers.

For detailed information on DI structure and use, see ANS MH10.8.2.

E.2 ASC MH10 Data Identifier (DI) serial identification

E.2.1 DI 18S

DI 18S is the “CAGE Code and Serial Number unique within CAGE”. To breakout the serial number, a software algorithm can be constructed which subtracts the CAGE Code from the 18S associated data content.

E.2.2 DI 25S

DI 25S is the “identification of a party to a transaction as identified in 18V, followed by the supplier assigned serial number”. To breakout the serial number, a software algorithm can be constructed to subtract the IAC and associated Enterprise Identifier from the 25S associated data content.

Table E.1 — Data Identifier approach

Essential data		
Element	Data Identifiers	Valid values/size (characters) ^e
Enterprise Identifier^a		
EAN.UCC	3V	6 to 13 characters, numeric
CAGE	17V	5 characters, alphanumeric
DUNS	12V	9 characters, numeric
Unique Product/Part Serial Number^{a, b, c}		
CAGE Code and Serial Number unique within CAGE	18S	5 characters, alphanumeric, plus 1 to 20 characters, alphanumeric
Ull — Item	25S	1 to 20 characters, alphanumeric
Traceability Number (lot, batch, etc.)	1T	Unformatted Data ^e
Current Product/Part Identifier^d		
Item Information First Level (Supplier Assigned)	30P	Unformatted Data ^e
Optional data		
Traceability element	To be determined by trading partners	f
<p>^a Permanent identification is the combination of Enterprise Identifier and the Unique Product/Part Serial Number within the Enterprise Identifier.</p> <p>^b Unique Product/Part Serial Number is assigned by the original manufacturer and is unique within the Enterprise Identifier of the manufacturer.</p> <p>^c The 18S identification number assigned by the original manufacturer shall stay with the product/part for its entire life cycle. It shall not be changed or removed from the product/part even if the product/part ownership changes.</p> <p>^d Current Product/Part Identifier (Number) is assigned by the organization responsible for configuration of the part. The responsible organization is normally Engineering. The Current Product/Part Number is a unique number assigned to one or more like units which have the same form, fit and function. The Current Product/Part Number marking should be separate from the permanent identification marking so that it can be updated over the life cycle of the part when the form, fit or function changes.</p> <p>^e When defining the valid values/size of the data content, one should consider</p> <ul style="list-style-type: none"> — first, the values/size defined in ANS MH10.8.2; — second, if not defined in ANS MH10.8.2, the data content values/size for the corresponding TEI; — third, data content values/size agreed between trading partners. <p>^f For traceability data element selection, use Data Identifiers in accordance with ANS MH10.8.2.</p>		

Annex F (normative)

Encoding comparison

F.1 Purpose

ISO/IEC 15434 defines a syntax which is used in many applications. This annex provides a comparison of the matrix symbol encoding and message syntax prescribed in 7.2 with the ISO/IEC 15434 syntax. The data string described as “Encoding” is the data string that is either received by the symbol encoding software which then converts it to codewords and symbol characters according to the symbology specification — making use of features of the symbology that permit efficient encoding — or output by the symbol decoder which converts the symbol characters back to bytes corresponding to the input.

F.2 Examples

F.2.1 Permanent identification data

Permanent identification data to be encoded and communicated is as follows.

Enterprise Identifier (CAGE/NCAGE): 2D671

Unique Product/Part Serial Number: ABC333-001

F.2.2 ISO 21849 with XML syntax for messages

Encoding in matrix symbol: CAG 2D671/SER ABC333-001

NOTE 1 The forward oblique stroke ‘/’ data separator that appears in the Data Matrix line above is permitted prior to sunset as described in 7.2.

Communication Message (XML): <CAG>2D671</CAG> <SER>ABC333-001</SER>

NOTE 2 The three upper-case alpha TEI characters are used as the well-formed, self-describing **NAME** in an XML Start-Tag and End-Tag.

F.2.3 ISO/IEC 15434 syntax

Encoding in matrix symbol: $[\]>^R_S DD^G_S CAG\ 2D671^G_S SER\ ABC333-001^R_S E_{o_T}$

NOTE The US Department of Defense has designated ‘DD’ as the Format Indicator to use for identifying TEIs until a permanent Format Indicator is assigned by ISO/IEC. Thereafter, the letters ‘DD’ will be substituted by the two-digit combination assigned to TEIs in a revision of ISO/IEC 15434. At the time of preparation of this International Standard, ISO/IEC 15434 was under revision to provide Format Indicator 12 to represent data using TEIs.

Using the proposed Format Indicator 12 for TEIs, the data stream would be as shown below.

Encoding in matrix symbol: $[\]>^R_S 12^G_S CAG\ 2D671^G_S SER\ ABC333-001^R_S E_{o_T}$

Annex G (informative)

Legacy part identification schema

G.1 Purpose

The type of schema employed for part identification is dependent on the method of serialization used for a product/part. The schema used in the body of this International Standard is based on assigning a unique serial number within the Enterprise Identifier.

This annex describes an approach in which a Sequential Serial Number is sequenced within the Original Part Number, and the Original Part Number is unique within the Enterprise Identifier. Millions of in-service parts have been identified with this approach using human-readable characters marked on a data plate.

G.2 Legacy schema

If a group of trading partners or a company desires to use a Sequential Serial Number within the Original Part Number approach to permanently identify a part using automated identification technologies, the schema illustrated in Figure G.1 shall be employed. Appropriate TEIs to use this schema are contained in Annexes A and B.

Data element title	Example
Enterprise Identifier	CAG 1C275
Original Part Number	PNO A765982C567
Sequential Serial Number within the Original Part Number	SEQ XYZ79865

Figure G.1 — Legacy part identification schema and example

If trading partners agree to uniquely identify lot number within the Original Part Number (PNO), use Lot Number (LOT) in lieu of the Sequential Serial Number (SEQ). The TEI for Enterprise Lot Number (LTN) shall not be utilized under this schema.

Annex H (informative)

Data exchange

H.1 Purpose

Organizations receiving products/parts identified by automatic identification techniques will need to be able to receive products with any of three semantic systems employed: EAN.UCC Application Identifiers (AI), ISO/IEC 15418 ASC MH10 Data Identifiers (DI), and ISO 21849 Text Element Identifiers (TEI). Two methods are available to permit data interchange between the three semantic systems: a standardization approach and a technical/interoperability approach.

H.2 Standardization approach

This method uses the ISO/IEC 15434 structure to obtain data interchange between the three commonly employed semantic systems. It cannot be used for data encoded in linear symbols.

NOTE This approach cannot be universally applied until TEIs are included in ISO/IEC 15434. The US Department of Defense has designated 'DD' as the Format Indicator to use for identifying TEIs until a permanent Format Indicator is assigned by ISO/IEC.

Data streams from the decoder are identified by means of

- a) a compliance indicator [four characters, [>] followed by R_S (character value 30)], followed by
- b) the Format Header consisting of a two-digit Format Identifier in the range 01–99 and the remainder of the header.

Format Header 05 G_S indicates data structured according to the EAN.UCC Application Identifier rules and using G_S (character value 29) as the data element delimiter; Format Header 06 G_S indicates data structured according to the ASC MH10 Data Identifier rules and using G_S (character value 29) as the data element delimiter; the non-standard Format Header DD G_S indicates data structured according to the US Department of Defense interim recommendation and using G_S (character value 29) as the data element delimiter. The end of the data string for a particular format is indicated by the Format Trailer character R_S and the end of the complete message by E_{OT} .

Data streams from a linear symbol shall be parsed according to

- a) the symbology identifier prefixed to the decoder output, and
- b) the format of the first 1 to 4 characters.

Symbology identifier]C1 indicates a UCC/EAN-128 symbol with an initial FNC1 character (not transmitted) containing EAN.UCC Application data. The first two data characters are looked up in the AI list; if no match is found, the first three characters are looked up; and if no match is found, the first four characters are looked up. If a match is found, the next data character is interpreted in accordance with the rules for the particular AI. Subsequent data (which may include the FNC1 character as a data element separator) are then analysed in a similar manner until the end of the symbol data string.

Any other symbology identifier present at the beginning of the transmission (the character ']' followed by two more characters) may be interpreted in accordance with ISO/IEC 15424 and/or stripped. If the next character (or, if no symbology identifier is present, the first character) is upper-case alphabetic and followed by numeric data, it is an ASC MH10 Data Identifier and should be interpreted by reference to ANS MH10.8.2. Otherwise,

if the next character (or, if no symbology identifier is present, the first character) is upper-case alphabetic and followed by two more upper-case alphabetic characters and a space, it is assumed to be a TEI. However, if there is no space in the fourth position, it is assumed that the first alpha character is a DI and should be interpreted by reference to ANS MH10.8.2. Validate the data following the assumed TEI or DI by reference to the relevant definitions. Otherwise, if in the next four positions there are one, two or three numeric digits followed by an upper-case alphabetic character, the two, three or four characters are an ASC MH10 Data Identifier.

H.3 Technical/interoperability approach

Figure H.1 provides a top level view of the process used to differentiate between AIs, DIs, and TEIs. This International Standard does not specify any particular method by which the process can be implemented, in order to enable solution providers to utilize an approach best suited to their requirements.

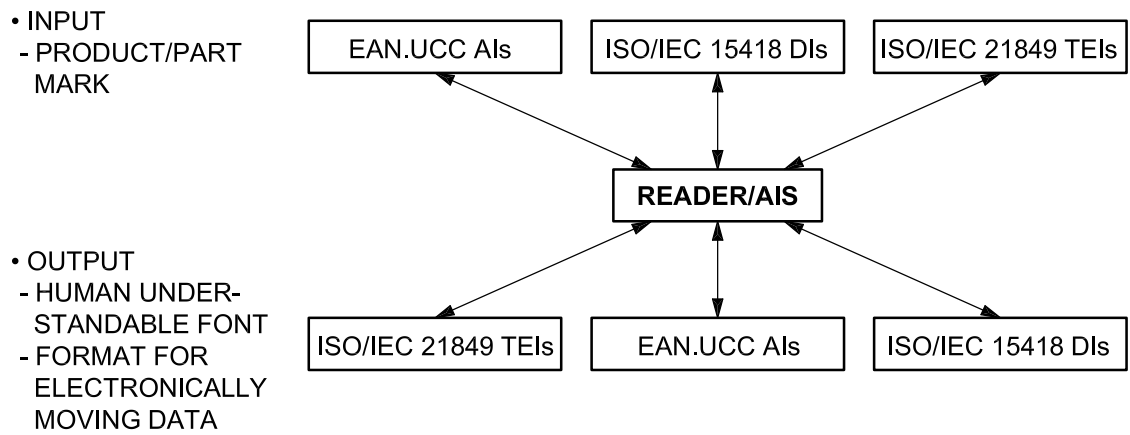

Figure H.1 —Top level technical approach

Annex I (informative)

RFID tag

I.1 General

RFID technology provides features that allow new operational processes to be implemented. Two of the key features are

- encoded data can be updated without physical alteration to the tag or part, and
- the data storage capability of the tag provides an abbreviated data base.

However, the affixing of an RFID tag does not obviate the necessity to provide an optically readable Data Matrix and a visually readable human translation markings (see Figures 2 b), 3 b) and I.7).

The abbreviated data base capability allows product/part traceability data to be stored in the tag in addition to essential identification and configuration data. Traceability data stored in the tag allows maintenance personnel to install a part without connection to an authoritative source of data. Business processes shall be established to ensure validation of the data in the tag with an authoritative source of data before the mechanic is issued the part.

I.2 Tag characteristics

The applied RFID technology shall be passive RFID transponders to prevent uncontrolled emission of electromagnetic waves in the aerospace operating environment.

The air interface and the communications protocol associated with RFID are identified in external documents published by ISO/IEC and EPCglobal.

I.3 Data content

Data content shall be as defined in 8.6.

The data shall be encoded in the tag using XML.

I.4 Data validation

Because the data in the tag can be updated, data validation procedures are required. Data is divided into static (permanent) or dynamic (updatable) data. Static data shall be written in the memory chip during or immediately after manufacturing of the product/part has been completed. Static data shall not be changed again. Dynamic data may be updated during the life of the product/part by an authorized source. To ensure the validity of dynamic data, business processes shall be established to identify who is authorized to update the data in the memory chip and when the data should be updated. An electronic audit trail shall be established at an industry level or by the trading partners to reflect all changes made to the dynamic data.

I.5 Static data

Static data shall be in a locked section in the RFID memory chip. Static data shall be written once and never changed during the life cycle of the product/part.

I.6 Dynamic data

Dynamic data elements shall be in a section in the RFID memory chip that may be updated. Updating shall only be accomplished by an authorized source.

I.7 Optically readable data

The top cover of the tag shall contain the Conformance Class 1 essential data in two matrix symbols and human translation formats. Human-readable data is required so that identification of a product/part can be made in the event that either no reader equipment is available or there is a reader/tag malfunction.

Encoding of the data in the matrix symbol shall be in accordance with ISO/IEC 15434 syntax. The requirements in Clauses 5 and 8 apply.

Annex J (informative)

Quality level, directly marked matrix symbols

Symbols and text produced by dot peening shall meet the requirements defined in SAE AS9132 and the tolerances defined in the appendix titled “Examples of Required Tolerances with Reference to the Nominal Cell Sizes for Dot Peening”.

Symbols and text produced by the industrial ink jet process, which uses round dots to form a cell, should meet the SAE AS9132 dot peening requirements appropriate to this process.

Symbols and text produced by laser and electro-chemical etching shall meet the requirements defined in SAE AS9132 and should achieve a rating of not less than 6 on the “Visual Quality Guidelines”.

Symbols and text produced by the ink stencil process, which creates square cells, should meet the SAE AS9132 laser and electro-chemical etching requirements appropriate to this process.

ISO/IEC TR 24720 and SAE AS9132 give useful guidelines for maximizing the readability of direct marked symbols.

Bibliography

- [1] ISO/IEC Directives, Part 2, *Rules for the structure and drafting of International Standards, fifth edition, 2004*
- [2] ISO 31 (all parts), *Quantities and units*
- [3] ISO 690, *Documentation — Bibliographic references — Content, form and structure*
- [4] ISO 1000, *SI units and recommendations for the use of their multiples and of certain other units*
- [5] ISO/IEC 2382-4, *Information technology — Vocabulary — Part 4: Organization of data*
- [6] ISO 3166-1, *Codes for the representation of names of countries and their subdivisions — Part 1: country codes*
- [7] ISO 10241, *International terminology standards — Preparation and layout*
- [8] ISO/IEC 15424, *Information technology — Automatic identification and data capture techniques — Data Carrier Identifiers (including Symbology Identifiers)*
- [9] ISO/IEC 15961, *Information technology — Radio frequency identification (RFID) for item management — Data protocol: application interface*
- [10] ISO/IEC 15962, *Information technology — Radio frequency identification (RFID) for item management — Data protocol: data encoding rules and logical memory functions*
- [11] ISO/IEC 18000 (all parts), *Information technology — Radio frequency identification for item management*
- [12] ISO/IEC TR 24720, *Information technology — Automatic identification and data capture techniques — Guidelines for Direct Part Marking (DPM)³⁾*
- [13] ANS MH10.8.2, *Data Identifier and Application Identifier Standard*
- [14] IEC 60027 (all parts), *Letter symbols to be used in electrical technology*
- [15] ATA Spec 2000, *E-Business Specification for Materials Management*
- [16] Defense Logistics Agency Cataloging Handbook

3) To be published.

.....

ICS 35.240.60; 49.020

Price based on 58 pages