

---

---

## Gas turbine applications — Safety

*Applications des turbines à gaz — Sécurité*



Reference number  
ISO 21789:2009(E)

© ISO 2009

**PDF disclaimer**

This PDF file may contain embedded typefaces. In accordance with Adobe's licensing policy, this file may be printed or viewed but shall not be edited unless the typefaces which are embedded are licensed to and installed on the computer performing the editing. In downloading this file, parties accept therein the responsibility of not infringing Adobe's licensing policy. The ISO Central Secretariat accepts no liability in this area.

Adobe is a trademark of Adobe Systems Incorporated.

Details of the software products used to create this PDF file can be found in the General Info relative to the file; the PDF-creation parameters were optimized for printing. Every care has been taken to ensure that the file is suitable for use by ISO member bodies. In the unlikely event that a problem relating to it is found, please inform the Central Secretariat at the address given below.



**COPYRIGHT PROTECTED DOCUMENT**

© ISO 2009

All rights reserved. Unless otherwise specified, no part of this publication may be reproduced or utilized in any form or by any means, electronic or mechanical, including photocopying and microfilm, without permission in writing from either ISO at the address below or ISO's member body in the country of the requester.

ISO copyright office  
Case postale 56 • CH-1211 Geneva 20  
Tel. + 41 22 749 01 11  
Fax + 41 22 749 09 47  
E-mail [copyright@iso.org](mailto:copyright@iso.org)  
Web [www.iso.org](http://www.iso.org)

Published in Switzerland

# Contents

Page

Foreword .....	vii
Introduction.....	viii
<b>1</b> <b>Scope</b> .....	<b>1</b>
<b>2</b> <b>Normative references</b> .....	<b>1</b>
<b>3</b> <b>Terms and definitions</b> .....	<b>4</b>
<b>4</b> <b>List of significant hazards</b> .....	<b>5</b>
<b>5</b> <b>Safety requirements</b> .....	<b>6</b>
<b>5.1</b> <b>General</b> .....	<b>6</b>
<b>5.2</b> <b>Risk assessment</b> .....	<b>6</b>
<b>5.3</b> <b>Modifications and replacement parts</b> .....	<b>7</b>
<b>5.4</b> <b>Foreseeable misuse</b> .....	<b>7</b>
<b>5.5</b> <b>Lifetime</b> .....	<b>7</b>
<b>5.6</b> <b>Hazard combinations</b> .....	<b>7</b>
<b>5.7</b> <b>Noise</b> .....	<b>8</b>
<b>5.8</b> <b>Mechanical</b> .....	<b>8</b>
<b>5.8.1</b> <b>Guarding</b> .....	<b>8</b>
<b>5.8.2</b> <b>Accessibility for maintenance</b> .....	<b>8</b>
<b>5.8.3</b> <b>Casing design</b> .....	<b>9</b>
<b>5.8.4</b> <b>Gas turbine compressor surge</b> .....	<b>9</b>
<b>5.8.5</b> <b>Stability and handling</b> .....	<b>9</b>
<b>5.8.6</b> <b>Overload of rotating shafts due to torque</b> .....	<b>9</b>
<b>5.8.7</b> <b>Vibration</b> .....	<b>9</b>
<b>5.8.8</b> <b>Mechanical failure caused by corrosion</b> .....	<b>10</b>
<b>5.8.9</b> <b>Design methods and materials</b> .....	<b>10</b>
<b>5.8.10</b> <b>Gas turbine temperatures</b> .....	<b>10</b>
<b>5.8.11</b> <b>Environmental loads</b> .....	<b>10</b>
<b>5.8.12</b> <b>Assembly features</b> .....	<b>11</b>
<b>5.8.13</b> <b>Couplings</b> .....	<b>11</b>
<b>5.8.14</b> <b>Rotor bearings</b> .....	<b>11</b>
<b>5.8.15</b> <b>Rotating part failure</b> .....	<b>11</b>
<b>5.8.16</b> <b>Foreign object damage (FOD) screen</b> .....	<b>12</b>
<b>5.8.17</b> <b>Gearbox</b> .....	<b>12</b>
<b>5.8.18</b> <b>Starting systems</b> .....	<b>12</b>
<b>5.8.19</b> <b>Low ambient temperature conditions</b> .....	<b>13</b>
<b>5.9</b> <b>Gas turbine compressor air inlet system</b> .....	<b>13</b>
<b>5.9.1</b> <b>General</b> .....	<b>13</b>
<b>5.9.2</b> <b>Inlet air contamination</b> .....	<b>13</b>
<b>5.9.3</b> <b>Icing monitoring and prevention</b> .....	<b>13</b>
<b>5.9.4</b> <b>Implosion protection</b> .....	<b>14</b>
<b>5.9.5</b> <b>Inlet explosion protection</b> .....	<b>14</b>
<b>5.9.6</b> <b>Waste disposal through combustion</b> .....	<b>14</b>
<b>5.9.7</b> <b>Recirculation</b> .....	<b>15</b>
<b>5.9.8</b> <b>Gas turbine compressor air inlet ducting</b> .....	<b>15</b>
<b>5.10</b> <b>Fuel systems</b> .....	<b>15</b>
<b>5.10.1</b> <b>General</b> .....	<b>15</b>
<b>5.10.2</b> <b>Fuel supply quality and supply conditions</b> .....	<b>15</b>
<b>5.10.3</b> <b>Pressure testing</b> .....	<b>16</b>
<b>5.10.4</b> <b>Fuel supply heating</b> .....	<b>16</b>
<b>5.10.5</b> <b>Gas fuel systems</b> .....	<b>16</b>

5.10.6	Liquid fuel systems .....	20
5.10.7	Multi-fuel systems.....	23
5.10.8	Fuel purging .....	23
5.10.9	Fuel drainage.....	24
5.11	Combustion supervision.....	24
5.11.1	General.....	24
5.11.2	Requirements for ignition .....	24
5.11.3	Extinction safety time.....	25
5.12	Exhaust system.....	25
5.12.1	Damper controls .....	25
5.12.2	Flexible joint location .....	25
5.12.3	Exhaust stack.....	25
5.12.4	Explosion protection .....	25
5.13	Enclosures.....	26
5.13.1	General.....	26
5.13.2	Enclosure structure .....	26
5.13.3	Enclosure fire precautions.....	27
5.13.4	Explosion prevention and protection — Area classification — Ventilation .....	27
5.13.5	Gas detection .....	27
5.13.6	Enclosure purging .....	27
5.13.7	Mist detection.....	27
5.13.8	Access and doors .....	28
5.13.9	Entrapment .....	28
5.14	Lighting.....	28
5.15	Fire precautions .....	28
5.15.1	General.....	28
5.15.2	Structural fire risk reduction .....	28
5.15.3	Hydrocarbon fire risk reduction .....	29
5.15.4	Fire protection.....	29
5.15.5	Fire detection .....	30
5.15.6	Fire extinguishing systems.....	30
5.15.7	Water mist extinguishant .....	31
5.15.8	Extinguishing system controls .....	31
5.15.9	Escape.....	33
5.15.10	Uncontrolled release of media and loss of propellant pressure.....	33
5.15.11	Vessel thermal relief (burst disc) .....	33
5.15.12	Vessel and/or pipe failure .....	33
5.15.13	Release of extinguishant into gas turbine halls, control rooms, etc. ....	34
5.16	Hazardous area classification and explosion prevention and protection .....	34
5.16.1	General.....	34
5.16.2	Area classification .....	34
5.16.3	Explosion prevention .....	34
5.16.4	Ignition source control.....	35
5.16.5	Reduction of explosion effects in an enclosed space .....	35
5.17	Ventilation.....	37
5.17.1	General.....	37
5.17.2	Cooling.....	37
5.17.3	Heating .....	37
5.17.4	Hazardous area control .....	38
5.17.5	Hot surfaces .....	38
5.17.6	Ventilation inlet location .....	38
5.17.7	Ventilation inlet filtration.....	38
5.17.8	Ventilation inlet ducting .....	38
5.17.9	Ventilation outlet location .....	39
5.17.10	Flow monitoring — Artificial ventilation.....	39
5.18	Fans.....	39
5.18.1	Fan guards and structural failure.....	39
5.18.2	Air blast oil coolers.....	39
5.19	Flammable gas detection .....	39
5.19.1	General.....	39

5.19.2	Type/selection principles.....	39
5.19.3	Location principles.....	40
5.19.4	Settings.....	40
5.19.5	Enclosures containing hot surfaces — Screening tool.....	40
5.19.6	Maintenance and calibration.....	40
5.20	Control and automatic protection systems.....	41
5.20.1	General.....	41
5.20.2	Environmental suitability.....	41
5.20.3	Ergonomics.....	41
5.20.4	Failure.....	41
5.20.5	Calibration.....	41
5.20.6	Testing.....	41
5.20.7	Speed control.....	42
5.20.8	Gas turbine emergency shut-down system.....	42
5.20.9	Interlocks.....	43
5.21	Electrical.....	43
5.21.1	Design/Installation.....	43
5.21.2	Isolation and stored energy.....	43
5.21.3	Electrostatic energy and bonding.....	44
5.21.4	Water ingress.....	44
5.21.5	Lightning.....	44
5.21.6	Electromagnetic compatibility (EMC).....	44
5.21.7	Battery installations.....	45
5.21.8	Electrical overload.....	45
5.21.9	Electrical power failure.....	45
5.22	Drains, vents and bleeds.....	45
5.22.1	General.....	45
5.22.2	Vents for flammable gases.....	46
5.22.3	Toxic and hazardous emissions.....	46
5.22.4	Gas turbine compressor bleeds.....	46
5.23	Pressure equipment.....	47
5.23.1	General.....	47
5.23.2	Design.....	47
5.23.3	Hazards.....	47
5.23.4	Misuse.....	47
5.23.5	Safe handling and operation.....	47
5.23.6	Isolation, draining and venting.....	48
5.23.7	Fluid injection.....	48
5.23.8	Assemblies.....	48
5.23.9	Safety accessories.....	49
5.23.10	Flexible piping (and metal hoses).....	50
5.23.11	External fire.....	50
5.23.12	Material embrittlement and corrosion.....	50
5.23.13	Ultra-violet (UV) resistant pipework.....	51
5.24	Auxiliary systems.....	51
5.24.1	Lubrication systems.....	51
5.24.2	Water systems.....	51
5.24.3	Hydraulic and pneumatic systems.....	52
5.24.4	Utility supplies.....	52
5.25	Installation in a hazardous area.....	52
5.26	Unenclosed gas turbines in a hall.....	53
5.27	Decommissioning and disposal.....	53
6	Compliance verification.....	53
6.1	Quality assurance.....	53
6.2	Verification of safety requirements.....	54
7	Information for use.....	54
7.1	General.....	54
7.2	Language.....	54
7.3	Packaging.....	54

7.4	Commissioning .....	54
7.5	Operation .....	55
7.5.1	General.....	55
7.5.2	Safety instructions and emergency procedures .....	56
7.6	Enclosure access.....	57
7.6.1	General.....	57
7.6.2	Risk assessment for accessing enclosures .....	57
7.6.3	Limitations under operational conditions .....	58
7.6.4	Limitations under non-operational conditions .....	58
7.6.5	Access during commissioning and re-commissioning .....	58
7.6.6	Installations in a hazardous area .....	58
7.7	Maintenance .....	58
7.7.1	General.....	58
7.7.2	General maintenance hazards .....	59
7.7.3	Accessibility, isolation and energy dissipation.....	59
7.7.4	Pressure equipment .....	59
7.7.5	Fire protection systems .....	60
7.7.6	Gas detectors .....	60
7.7.7	Control systems: maintenance, calibration and testing.....	60
7.7.8	Hazardous materials .....	61
7.8	Warning signs and notices .....	61
7.9	Permit to work (PTW).....	62
7.10	Training .....	62
7.11	Decommissioning and disposal.....	62
Annex A (informative) List of significant hazards.....		63
Annex B (normative) Verification of safety requirements and/or measures.....		71
Bibliography .....		77
Index.....		79

## Foreword

ISO (the International Organization for Standardization) is a worldwide federation of national standards bodies (ISO member bodies). The work of preparing International Standards is normally carried out through ISO technical committees. Each member body interested in a subject for which a technical committee has been established has the right to be represented on that committee. International organizations, governmental and non-governmental, in liaison with ISO, also take part in the work. ISO collaborates closely with the International Electrotechnical Commission (IEC) on all matters of electrotechnical standardization.

International Standards are drafted in accordance with the rules given in the ISO/IEC Directives, Part 2.

The main task of technical committees is to prepare International Standards. Draft International Standards adopted by the technical committees are circulated to the member bodies for voting. Publication as an International Standard requires approval by at least 75 % of the member bodies casting a vote.

Attention is drawn to the possibility that some of the elements of this document may be the subject of patent rights. ISO shall not be held responsible for identifying any or all such patent rights.

ISO 21789 was prepared by Technical Committee ISO/TC 192, *Gas turbines*.

## Introduction

This document is a type C standard as stated in ISO 12100 (all parts). A type C standard is “a standard dealing with the detailed safety requirements for a particular machine or group of machines”.

The machinery concerned and the extent to which hazards, hazardous situations and hazardous events are covered are indicated in the Scope of this International Standard.

When provisions of this type C standard are different from those that are stated in type A or B standards, the provisions of this type C standard take precedence over the provisions of the other standards for machines that have been designed and built according to the provisions of this type C standard.

The extent of the applicability of the references may be limited by the context of the text within ISO 21789. Where a dated standard is specified this does not preclude the use of later versions provided that the requirements continue to meet the safety issues and identified hazards detailed in this standard. Where a reference is made to a specific clause in a standard only the text of that clause and references therein apply.<sup>1)</sup>

In addition to covering the relevant safety requirements, this International Standard has also been produced to assist designers, manufacturers and others by providing methods of compliance with the relevant, essential safety requirements of the following European Legislation for gas turbine applications without prejudicing compliance with this International Standard outside the European Union:

- Machinery Directive (2006/42/EC);
- ATEX (Equipment) Directive (94/9/EC);
- Pressure Equipment Directive (97/23/EC).

Methods are also provided as far as practical and where relevant for compliance with the relevant, essential safety requirements of the following European Legislation:

- ATEX (Workplace) Directive (1999/92/EC);
- Low Voltage Directive (2006/95/EC);
- Electromagnetic Compatibility Directives (91/236/EEC – 92/31/EEC – 93/68/EEC – 2004/108/EC);
- Integrated Pollution Prevention and Control Directive (96/61/EC);
- Environmental Noise Directive (2002/49/EC);
- Chemical Agents Directive (98/24/EC);
- Classification, Packaging, and Labelling of Dangerous Substances Directive (97/69/EC).

---

1) References within Notes are provisions but not normative provisions of this document and are listed in the Bibliography.



# Gas turbine applications — Safety

## 1 Scope

This International Standard covers the safety requirements for gas turbine applications using liquid or gaseous fuels and the safety related control and detection systems and essential auxiliaries for all types of open cycles (simple, combined, regenerative, reheat, etc.) used in onshore and offshore applications including floating production platforms.

This International Standard applies to driven machinery only where it is an integral part of the gas turbine (e.g. a gearbox integral to the gas turbine), or is located within the gas turbine enclosure and forms part of the enclosure hazardous area classification (e.g. a generator within the gas turbine enclosure), or where the driven machinery has a direct effect on the operational safety of the gas turbine.

This International Standard details the anticipated significant hazards associated with gas turbines and specifies the appropriate preventative measures and processes for reduction or elimination of these hazards. This International Standard addresses the risks of injury or death to humans and risks to the environment. Equipment damage without risk to humans or the environment is not covered.

Gas turbine packages are generally specified using International Standards and national standards. Achieving safety is promoted by using additional safety codes and standards, which are shared by gas turbines with other technologies. It is necessary to recognize that local legislation in the country in which the equipment is to be put to use may not be covered by this International Standard.

This International Standard approaches gas turbine safety from an international perspective based on the content of existing, recognized ISO and IEC standards to the greatest extent possible. Where no ISO or IEC standard exists, other codes or standards (such as EN, NFPA, etc.) have been included. Where local or national legislation accepts other established codes or standards, or an alternative international or national standard providing equivalent requirements for achieving the desired tolerable level of risk, the use of these alternative codes or standards in place of the references provided in Clause 2 is permissible.

This International Standard excludes gas turbines used primarily for direct and indirect propulsion, special heat source applications and in research and development programmes. It also excludes gas turbines for closed-cycle and semi-closed cycle applications, and compressed-air energy storage plants. Where appropriate, this International Standard can be used to give general guidance in such applications.

This document is not applicable to machinery or safety components that were manufactured before the date of its publication as an International Standard.

## 2 Normative references

The following referenced documents are indispensable for the application of this document. For dated references, only the edition cited applies. For undated references, the latest edition of the referenced document (including any amendments) applies.

ISO 3977-1:1997, *Gas turbines — Procurement — Part 1: General introduction and definitions*

ISO 3977-3:2004, *Gas turbines — Procurement — Part 3: Design requirements*

ISO 3977-9:1999, *Gas turbines — Procurement — Part 9: Reliability, availability, maintainability and safety*

## ISO 21789:2009(E)

ISO 4413:1998, *Hydraulic fluid power — General rules relating to systems*

ISO 4414:1998, *Pneumatic fluid power — General rules relating to systems*

ISO 4871:1996, *Acoustics — Declaration and verification of noise emission values of machinery and equipment*

ISO 6183:1990, *Fire protection equipment — Carbon dioxide extinguishing systems for use on premises — Design and installation<sup>2)</sup>*

ISO 10441:2007, *Petroleum, petrochemical and natural gas industries — Flexible couplings for mechanical power transmission — Special-purpose applications*

ISO 10494:1993, *Gas turbines and gas turbine sets — Measurement of emitted airborne noise — Engineering/survey method*

ISO 11086:1996, *Gas turbines — Vocabulary*

ISO 12100-1:2003, *Safety of machinery — Basic concepts, general principles for design — Part 1: Basic terminology, methodology*

ISO 12100-2:2003, *Safety of machinery — Basic concepts, general principles for design — Part 2: Technical principles*

ISO 12499:1999, *Industrial fans — Mechanical safety of fans — Guarding*

ISO/TR 13387-7:1999, *Fire safety engineering — Part 7: Detection, activation and suppression*

ISO 14001:2004, *Environmental management systems — Requirements with guidance for use*

ISO 14118:2000, *Safety of machinery — Prevention of unexpected start-up*

ISO 14120:2002, *Safety of machinery — Guards — General requirements for the design and construction of fixed and movable guards*

ISO 14121-1:2007, *Safety of machinery — Risk assessment — Part 1: Principles*

ISO 14123-1:1998, *Safety of machinery — Reduction of risks to health from hazardous substances emitted by machinery — Part 1: Principles and specifications for machinery manufacturers*

ISO 14520-1:2006, *Gaseous fire-extinguishing systems — Physical properties and system design — General requirements*

ISO 14691:1999, *Petroleum and natural gas industries — Flexible couplings for mechanical power transmission — General purpose applications<sup>2)</sup>*

ISO 19353:2005, *Safety of machinery — Fire prevention and protection*

IEC 60079-0:2007, *Explosive atmospheres — Part 0: Equipment — General requirements*

IEC 60079-4:1975, *Electrical apparatus for explosive gas atmospheres — Part 4: Method of test for ignition temperature*, amended by IEC 60079-4-AM:1995

IEC 60079-10, *Electrical apparatus for explosive gas atmospheres — Part 10: Classification of hazardous areas*

---

<sup>2)</sup> Replaced by ISO 14691:2008, *Petroleum, petrochemical and natural gas industries — Flexible couplings for mechanical power transmission — General-purpose applications*.

- IEC 60079-14:2007, *Explosive atmospheres — Part 14: Electrical installations design, selection and erection*
- IEC 60079-17:2007, *Explosive atmospheres — Part 17: Electrical installations inspection and maintenance*
- IEC/TR 60079-20:1996, *Electrical apparatus for explosive gas atmospheres — Part 20: Data for flammable gases and vapours, relating to the use of electrical apparatus*
- IEC 60079-29-1:2007, *Explosive atmospheres — Part 29-1: Gas detectors — Performance requirements of detectors for flammable gases*
- IEC 60079-29-2:2007, *Explosive atmospheres — Part 29-2: Gas detectors — Selection, installation, use and maintenance of detectors for flammable gases and oxygen*
- IEC 60204-1:2005, *Safety of machinery — Electrical equipment of machines — Part 1: General requirements*
- IEC 60204-11:2000, *Safety of machinery — Electrical equipment of machines — Part 11: Requirements for HV equipment for voltages above 1 000 V a.c. or 1 500 V d.c. and not exceeding 36 kV*
- IEC 60529:2001, *Degrees of protection provided by enclosures (IP Code)*
- IEC 60695-1-1:1999, *Fire hazard testing — Part 1-1: Guidance for assessing the fire hazard of electrotechnical products — General guidelines*
- IEC/TR 61000-5-1:1996, *Electromagnetic compatibility (EMC) — Part 5: Installation and mitigation guidelines — Section 1: General considerations — Basic EMC publication*
- IEC/TR 61000-5-2:1997, *Electromagnetic compatibility (EMC) — Part 5: Installation and mitigation guidelines — Section 2: Earthing and cabling*
- IEC 61000-6-2:2005, *Electromagnetic compatibility (EMC) — Part 6: Generic standards — Section 2: Immunity for industrial environments*
- IEC 61000-6-4:2006, *Electromagnetic compatibility (EMC) — Part 6: Generic standards — Section 4: Emission standard for industrial environments*
- IEC 61508-1:1998, *Functional safety of electrical/electronic/programmable electronic safety related systems — Part 1: General requirements*
- IEC 61511-1:2003, *Functional safety — Safety instrumented systems for the process industry sector — Part 1: Framework, definitions, system, hardware and software requirements*
- EN 1127-1:2007, *Explosive atmospheres — Explosion prevention and protection — Part 1: Basic concepts and methodology*
- EN 13463-1:2001, *Non-electrical equipment for potentially explosive atmospheres — Part 1: Basic method and requirements*
- EN 50272-2:2001, *Safety requirements for secondary batteries and battery installations — Stationary batteries*
- NFPA 12:2008, *Standard on Carbon Dioxide Extinguishing Systems*
- NFPA 13:2007, *Installation of Sprinkler Systems*
- NFPA 15:2007, *Water Spray Fixed Systems for Fire Protection*
- NFPA 68:2007, *Standard on Explosion Protection by Deflagration Venting*
- NFPA 750:2006, *Standard on Water Mist Fire Protection Systems*
- NFPA 2001:2008, *Clean Agent Fire Extinguishing systems*

### 3 Terms and definitions

For the purposes of this document, the terms and definitions given in ISO 3977-1:1997, ISO 3977-3:2004, ISO 3977-9:1999, ISO 11086:1996 and ISO 12100-1:2003 and the following apply.

#### 3.1 auto-ignition temperature AIT

lowest temperature in degrees Celsius of a heated surface at which the ignition of a combustible substance in the form of gas or vapour mixture with air can occur

NOTE AIT is also referred to as ignition temperature, minimum ignition temperature or self-ignition temperature in other standards and in the literature (see 5.16.4.4).

#### 3.2 drain valve

valve that is intended to remove liquids from a pipework system, and that normally drains to atmospheric pressure

#### 3.3 extinction safety time

maximum allowable period of time between the direct or indirect detection of loss of combustion and cessation of the fuel supply

#### 3.4 foreseeable lifetime

foreseeable lifetime includes all phases of life of a part or a system, for example, but not limited to, construction, transportation, commissioning, use, operation, cleaning, trouble-shooting, maintenance, decommissioning, dismantling, final disposal, etc.

#### 3.5 ignition safety time

maximum allowable period of time between the opening of the fuel supply valve, which permits fuel to flow, and cessation of the fuel supply, in the absence of confirmation that combustion has commenced (e.g. unsuccessful ignition)

#### 3.6 interlock interlocking device

mechanical, electrical or other type of device, the purpose of which is to prevent the operation of machine elements under specified conditions by an inhibit command from the interlocking device that

- a) directly interrupts the energy supply or directly disconnects parts from the equipment, or
- b) is introduced into the control system so that interruption of the energy or disconnection of parts from the equipment is triggered by the control system

#### 3.7 lower explosive limit LEL

volume concentration of flammable gas or vapour in air, below which the mixture is not explosive

NOTE The terms "explosive limit" and "flammable limit" are equivalent.

#### 3.8 operator

person or organization having responsibility for the operation of the equipment

**3.9****original equipment manufacturer  
OEM**

person or company having design responsibility for the equipment or for parts of it

NOTE This may be the manufacturer/packager of the equipment.

**3.10****packager**

supplier(s) having responsibility for integrating the technical aspects of the equipment and all auxiliary systems included in the scope of the supply

**3.11****purchaser**

person or company having authority to specify and to buy the equipment

NOTE This, in some cases, may designate the operator.

**3.12****relief valve**

safety device used for over-pressure protection and which does not operate under normal running conditions

**3.13****safety device**

all elements that are used to measure, limit or control safety relevant process variables, for processing safety relevant signals or for activation of automatic or manual safety related interventions

**3.14****safety related system**

systems/components whose primary failure is shown by the failure analysis as likely to cause a hazard and can require special measures in order to achieve an acceptably low probability of occurrence

**3.15****spill valve**

control valve that is intended to divert a portion of the liquids during normal running conditions

**3.16****tolerable risk**

risk that is accepted within a given context based on the current values of society

NOTE See IEC 61511-3 and/or ISO/IEC Guide 51.

**3.17****valve pressure proving**

system to check the effective closure of automatic shut-off valves by detecting leakage

**3.18****vent**

opening intended to discharge gases, fumes or mists except the exhaust gas of the gas turbine, the latter being called the exhaust system

**4 List of significant hazards**

Anticipated significant hazards are listed in broad outline in Annex A, which indicates the significant corresponding preventative measures and which should be used in conjunction with Clauses 5, 6, and 7 to reduce or eliminate these hazards.

## 5 Safety requirements

### 5.1 General

The overall objective of the safety requirements is to ensure that equipment is designed and maintained throughout its life to attain an appropriate level of safety for its intended application.

To achieve this, the safety management process shall consist of the following three levels, applied in the order shown:

- design for safety with passive means;
- apply active measures (e.g. automatic protection intervention if preset limit values are exceeded);
- communicate the residual risk to the operator by instructions to reduce the risk to a tolerable level.

For relevant hazards which are not dealt with by this International Standard, the machinery should be assessed in accordance with the principles of ISO 12100-1 and ISO 12100-2.

The content of this International Standard should not prejudice technical advances in the field of gas turbine safety or be used to inhibit innovation that can lead to increased safety.

### 5.2 Risk assessment

Risk assessments shall be performed to determine whether the gas turbine and associated equipment can cause injury to people or pose a threat to people's lives, or to the environment, or can cause significant collateral damage. The results of the assessments shall be documented. Where risk reduction measures are undertaken it is essential to ensure that additional measures do not introduce additional hazards. Risks identified during risk assessment should be eliminated but, where this is not possible, risks shall be reduced to a tolerable level for the associated consequence. Risk assessment is the overriding principal that should, where applicable, be applied to all the requirements of this International Standard.

The content of the risk assessment process should, as a minimum, address the safety issues raised within this International Standard considering reasonably foreseeable activities over the life cycle of the plant.

**NOTE 1** Safety is achieved by reducing risk to a tolerable level. Tolerable risk is determined by the search for an optimal balance between the ideal of absolute safety and the demands to be met by a product, process or service and factors such as benefit to the user, suitability for purpose, cost effectiveness and conventions of the society concerned. It follows that it is necessary to review continually the tolerable level, in particular when developments, both in technology and in knowledge, can lead to economically feasible improvements to attain the minimum risk compatible with the use of the product, process or service.

Where this International Standard states that the risk of a potential hazard shall be reduced to a tolerable level, and that hazard is associated with a safety related control function in conjunction with the associated system components (as mentioned in 5.20.1), a qualitative or quantitative risk assessment method shall be applied for the events to define the corresponding safety requirements and/or safety integrity level (SIL) of the protection system.

**NOTE 2** IEC 61511-3:2004, Annex B, outlines quantitative methods for risk assessment. IEC 61508-5:1998, Annexes D and E, outline qualitative methods for risk assessment for the purposes of determining SIL levels.

Where the reduction of potential hazards to a tolerable level of risk for components and/or equipment not associated with SILs is required, an appropriate quantitative or qualitative risk assessment or a mixture of both methods shall be used, where applicable, to ensure that a tolerable level of risk is achieved.

The general principles used for risk assessment shall comply with ISO 14121-1:2007.

**NOTE 3** In addition to the references in NOTE 2, detailed guidance on the risk assessment process and some of the techniques that can be used are given in IEC 60812:2006, IEC 61025:1990, IEC 61882:2001 and ANSI B11.TR3-2000.

The level of risk obtained shall assume that the requirements of this International Standard are being considered and that the operation and maintenance procedures ensure that the obtained levels of risk are maintained.

For quantitative risk assessments associated with the gas turbine(s) and the associated plant, it is recommended that common practice be followed in setting the maximum tolerable level of individual risk of fatality at  $10^{-3}$  per year for employees and  $10^{-4}$  for the public and the broadly acceptable level of individual risk to  $10^{-6}$  per year. Risks in the tolerable region should be identified as controlled and as low as reasonably practicable (ALARP) considerations applied. To achieve these levels of risk, an allowance should be applied to the risk levels achieved for each separate risk identified in this International Standard that can cause a fatality, such that the above levels are achieved for the gas turbine(s) and the associated plant when other sources of risk are considered by the plant operator.

NOTE 4 IEC 61511-3:2004, Annex A, provides an overview of the concepts of tolerable risk and ALARP. IGE/SR/15, Edition 4, Section 3, provides guidance on exposure to several hazards at one location.

For qualitative risk assessments care should be taken to ensure that the parameters used are clearly defined so that objective judgements can be made, and that the values used for each parameter are appropriately calibrated to ensure that they are valid for the assessment being undertaken.

NOTE 5 IEC 61511-3:2004, D.3, outlines the calibration process in the context of a risk graph and the principles described equally apply to other qualitative methodologies.

NOTE 6 Further guidance on individual levels of risk can be found in IGE/SR/15, Edition 4, Section 3.

Any residual risks shall be communicated to the operator who shall take additional mitigation action as necessary.

If new information that significantly affects a risk assessment becomes available, operators of affected equipment shall be advised.

### 5.3 Modifications and replacement parts

All modifications and updates/upgrades to protection systems and safety relevant components shall be implemented to achieve the required tolerable level of risk. Replacements of components beyond the requirements of normal maintenance as well as modifications and upgrades of equipment to newer technology require that a risk assessment be performed to ensure that the resulting level of risk remains tolerable.

### 5.4 Foreseeable misuse

Equipment and protective systems shall be designed and manufactured after due analysis of possible operating faults to preclude dangerous situations due to the consequences of reasonably foreseeable misuse.

### 5.5 Lifetime

Life predictions for safety related systems/components, including safety protection systems and components, shall be performed to establish that the gas turbine can be operated with a tolerable level of risk throughout its foreseeable lifetime.

Periodic maintenance of protection systems and safety relevant components shall be scheduled to ensure the safety of the plant. The redundancy of protection systems as designed shall be maintained during the lifetime of the plant.

### 5.6 Hazard combinations

Where the potential exists for gases, vapours, mists and liquids to mix and cause a hazardous situation or affect the operation of a safety device, appropriate measures shall be taken to mitigate the risk to a tolerable level.

Where fuel lines are purged or cooled by auxiliary media the risks associated with reverse flow and the discharges of mixtures shall be assessed and appropriate mitigation measures taken to reduce the risk to a tolerable level.

Where additives are used to enhance the properties of a given medium, a check shall be undertaken to ensure an unsafe situation is not created in the gas turbine or any associated equipment.

## **5.7 Noise**

Where the noise levels in work areas exceed 85 dB (A), warning signs shall be displayed at the entry to an area, building or enclosure indicating that personal ear protectors shall be used. Personal access to work areas with foreseeable, unweighted, instantaneous sound levels exceeding 140 dB (200 Pa) shall not be allowed.

Where high pressure/flow vents, bleeds or air/gas motor exhausts are utilized the design shall limit the velocity at the outlet, and silencers shall be fitted or outlets shall be located such that when the outlets discharge the limit to personal noise exposure of a worker specified above shall not be exceeded, or appropriate warning signs shall be located at a safe distance from the noise source.

## **5.8 Mechanical**

### **5.8.1 Guarding**

#### **5.8.1.1 General**

Guards shall be provided in accordance with ISO 14120:2002, against the mechanical hazards described in ISO 12100-1:2003, 4.2.

Where an enclosure with controlled access acts as a guard against moving mechanisms and hot surfaces the entry points shall have signs warning against the potential hazards.

#### **5.8.1.2 Hot and cold surfaces**

Equipment shall be designed so as to minimize the risk of burn injury caused by contact with or proximity to surfaces at high and low temperatures.

This can be achieved when the surface temperatures for incidental contact for a given material/finish do not exceed the burn threshold for a minimum contact period of 1 s. Where the threshold temperature is exceeded on normally accessible surfaces, appropriate guarding, barriers or other suitable measures shall be implemented to remove the potential for burns. On surfaces not normally accessed, warning sign(s) may be posted at a clearly visible location in the vicinity.

Typical 1 s burn threshold levels are 70 °C for uncoated metal, 80 °C for coated metal and 85 °C for glass. ISO 13732-1:2006 and ISO 13732-3:2005 may be used to determine if a potential risk of a burn is present.

For deliberate contact surfaces (e.g. manual valves and door handles), means shall be provided to ensure that the surface temperatures do not exceed the burn threshold for a contact time of 10 s.

Where personal injury can be caused by artificially cold surfaces created as a result of the operation of the equipment, protection measures shall be implemented or signs shall be displayed in the vicinity warning of the hazard.

### **5.8.2 Accessibility for maintenance**

Measures for safe access shall comply with ISO 12100-2:2003, 5.5.6.

Where access provisions are not available for non-operational maintenance, temporary access provisions shall be used.



Positioning of safety equipment and warning signs should be considered in the design phase to reduce the chance of injury during maintenance activities.

Where practicable, structural members or permanently installed equipment should not visually or physically obstruct adjustment, servicing, removal of replaceable equipment or other required maintenance tasks.

### 5.8.3 Casing design

Casings shall be designed to withstand the maximum reasonably foreseeable loads including transient and abnormal operating conditions (e.g. gas turbine compressor surge) without leading to a failure of the casing itself or its flanges. Hot air leakage that can cause damage or potential injuries shall be prevented.

Casings shall be designed or suitable guarding shall be provided to contain a blade-off event and the subsequent consequential damage, but not for a disc burst or overhang failure (see 5.8.15).

Non destructive testing, non destructive examination or pressure testing techniques shall be used to ensure the integrity of the casing under the relevant and reasonably foreseeable operating conditions.

### 5.8.4 Gas turbine compressor surge

In the event of a surge, the forces, deflections and consequences of flame reversal shall be mitigated to a tolerable level of risk during shut-down.

### 5.8.5 Stability and handling

Bearing supports, casings and, if used, base frames shall be mounted in their environment in a manner such that they remain in their intended position during all reasonably foreseeable events.

Where equipment is not suitable for manual handling, lifting arrangements shall be designed to transfer the load of the gas turbines or components smoothly from the normal supports to a resting place in a safe and controlled manner, taking account of dynamic and overturning loadings.

Where machinery is being moved that could, due to its own weight, lack of stability or the conditions under which the operation is being undertaken, create a crushing force causing injury, maintenance equipment shall be supplied that applies restraints to ensure that the potential for crushing is mitigated.

### 5.8.6 Overload of rotating shafts due to torque

Where there is the potential for faults in the driven machinery (e.g. short circuits) that under reasonably foreseeable circumstances can cause an overtorque greater than the specified design limits in the equipment drive shafts or the associated gas turbine rotor, a torque-limiting device or other appropriate measures shall be provided to prevent a dangerous failure.

If torque limiting devices are used for controlling this risk, the activation of such devices shall not change the bearing support condition of the shafts into a situation where overhanging rotors rotate above their critical speed.

### 5.8.7 Vibration

Where vibration levels in the drive shaft line/train can escalate to excessive levels resulting in the potential for dangerous situations, vibration monitoring equipment shall be installed to continuously monitor and detect any escalation and initiate appropriate action (e.g. shut-down) to bring the gas turbine to a safe condition if vibration levels exceed a preset limit.

### 5.8.8 Mechanical failure caused by corrosion

Mechanical properties of stressed or vibrating materials (e.g. rotors and piping) can be significantly affected by corrosion caused by the environment. Possible effects are reduction of the fatigue limit, stress corrosion cracking (SCC) and stress accelerated grain boundary oxidation (SAGBO). The supplier shall make sure that all necessary steps are taken to address hazards caused by these effects.

### 5.8.9 Design methods and materials

Gas turbines shall be designed so that, when correctly operated and maintained, the risks of failures that result in the release of high-energy debris, rupture of pressure casings or the release of hot, flammable or toxic gases are reduced to tolerable levels of risk for the lifetime of the machinery.

The selection and use of materials for the safety related parts of the gas turbine and its related systems shall be based on validated material data and validated design techniques. The selection shall consider the effects of material property deterioration due to manufacturing processes, environmental or operational causes. See also 5.23.13.

Where the use of titanium or magnesium based alloys creates a fire risk, measures to prevent a dangerous situation or extinguish such a fire shall be taken.

Components that are highly stressed (e.g. by aerodynamic or rotational loads and/or high temperature conditions) and that can fail and cause personal injury shall be identified and made traceable for quality control purposes.

The soundness of critical rotating components shall be confirmed by non-destructive testing combined with a fracture mechanics assessment, to indicate that the flaws present no risk at the acceptance limit. Analysis based on material tests shall be used to confirm that a tolerable level of risk is achieved over the range of operating speeds of the parts during their foreseeable lifetime. The analysis should at least take into account the risks of crack growth, elastoplastic deformation, creep, corrosion and fatigue failure.

If the failure of a driven equipment rotor has a direct effect on the safety of the gas turbine, the soundness of rotor materials shall be confirmed.

Materials of construction and methods of use shall be such as not to cause unacceptable effects on human health or the environment over the life cycle of the gas turbine system and its components.

### 5.8.10 Gas turbine temperatures

Protective measures (e.g. direct or indirect temperature monitoring, cooling air flow and calculation) shall be taken to prevent failures due to over temperature where the release of high-energy debris, rupture of pressure casings or the release of hot, flammable or toxic gases is likely to give rise to a hazard. If temperatures exceed the tolerated level, then gas turbine unloading to a safe condition or shut-down shall be initiated automatically.

### 5.8.11 Environmental loads

Machinery, support and enclosure structures, and associated auxiliary piping and ducting, shall be designed to withstand a reasonably foreseeable combination of loads caused by site winds, snow, ice and seismic activity without causing structural collapse or other dangerous situations. Local codes and standards normally govern the design, but where such local codes or standards do not exist, the purchaser shall specify the wind speed, snowfall and ice accumulation rates and seismic accelerations to be used.

For floating production storage and offloading vessels (FPSO) and floating production units (FPU) applications account shall be taken of the pitch and roll angles and acceleration forces generated by the vessel during operation and maintenance.

### 5.8.12 Assembly features

Gas turbine components whose correct assembly is safety related shall be protected from incorrect assembly in the field or during repair. These components shall undergo a review to determine if assembly features should be designed into the components and/or distinctive markings should be used and appropriately documented to minimize the risk of incorrect assembly.

### 5.8.13 Couplings

Flexible couplings external to the gas turbine core used to transmit the gas turbine output power shall use as guidelines the design requirements of ISO 14691:1999 for speeds up to 4 000 r/min and ISO 10441:1999 for speeds exceeding 4 000 r/min. Further, for critical service, ISO 10441:1999 should be used irrespective of speed. If rigid couplings are used, the supplier shall ensure that the coupling can transmit the torque.

### 5.8.14 Rotor bearings

Bearing design shall take into account the resulting effects and risks of the off balance of a spinning rotor due to the reasonably foreseeable loss of gas turbine compressor blades and/or turbine blades to ensure that unsafe conditions (uncontained failure, breached pressure casing, fire) do not result. Protective measures shall be taken to prevent the hazards of lube oil loss, fire, and explosion of lube oil vapour or mist (within and around the bearing compartment). Fire protection should be considered if high temperature surfaces that can ignite the lube oil exist in proximity to the bearing and lubricating oil.

### 5.8.15 Rotating part failure

#### 5.8.15.1 General

All gas turbine compressor and turbine rotating parts that are relevant for safety shall be designed for the conditions and stresses that they encounter during start-up, running, transient, shut-down or trip conditions.

#### 5.8.15.2 Rotor and disc failure

Due to the large amount of energy contained in the rotating components of a gas turbine, rotor or disc failure cannot always be contained. Therefore, the risk shall be assessed and reduced to a tolerable level with passive and active measures.

Passive measures should include a limitation of the speed to values below rotor failure speed by one or a combination of the following measures:

- a) prevention of further rotor acceleration by loss of blades due to centrifugal load, burning out or other effects;
- b) limitation of the speed at highest fuel flow due to aerodynamic effects in the blading of gas turbine compressor and turbine.

Active measures should include overspeed protection and the automatic drain of liquid fuel out of the casing before ignition, according to 5.10.9.

#### 5.8.15.3 Overhanging rotor parts

Overhanging rotor parts should not operate above or within an intolerable margin of their critical speed related to the first bending mode.

If overhanging rotor parts operate above their critical speed related to the first bending mode, calculations and test running on a prototype shall demonstrate that no unsafe vibration levels are reached.

### 5.8.16 Foreign object damage (FOD) screen

If there is a possibility of foreign objects entering the gas turbine and causing loss of containment of rotating parts, an FOD screen should be installed at the machine inlet to reduce the size of objects that can enter to that which is unlikely to cause such a failure. The location of the screen should be sufficiently upstream to avoid the potential for large objects to cause significant localized flow blockage that can induce blade failure.

### 5.8.17 Gearbox

Gear wheels are loaded with a superposition of residual stress, thermal stress and centrifugal stress, which are dependent on size and speed. This creates a risk of brittle fracture especially in the centre of the wheel body, which increases with size. This risk shall be addressed during production with non destructive testing of pinions and wheels combined with a fracture mechanics assessment, which indicates no risk emerging from flaws at the acceptance limit. Pinions or wheels, for which the acceptance limit of flaws cannot be achieved, shall undergo an appropriate overspeed proof test. This test shall be arranged such that the wheel is rotated up to a speed level that causes a tensile stress inside the disc exceeding the maximum operating stress level with the margin required to ensure the safety of any potential undetected internal flaw with respect to sub-critical crack growth and crack stability during the whole design life of the rotor.

Where the type or design of the gearbox is such that other components are loaded in the same manner as above and assessment indicates that an acceptance limit of flaws cannot be achieved, the gear shall be subjected to the same overspeed proof test described for the gear wheels to achieve the equivalent safety criterion. The oil inlet and drain temperatures should be recorded during the overspeed test.

Appropriate service factors should be applied to the gearbox design commensurate with the equipment to be driven and duty range in accordance with a recognized International Standard or national standard.

NOTE 1 See ISO 13691:2002, API 613 or AGMA 6011 for high speed gears.

NOTE 2 For epicyclic gears, reference can be made to the general guidelines in AGMA 6023.

Oil retention in gearbox casings, from gear transmissions with high pitchline velocities can lead to overheating of the oil resulting in oil fires or explosions. The gearcase design shall be such that sufficient free oil volume exists and adequate free drainage facilities are provided to avoid these hazards. Where such hazards cannot be eliminated by design, additional precautions shall be taken.

The oil supply conditions to the gearbox shall be monitored to ensure that the viscosity conditions used as the design basis are achieved to preclude premature wear and failure.

The gearbox design shall prevent failure under the overload conditions described in 5.8.6.

### 5.8.18 Starting systems

The starting system shall be suitable for the acceleration of the gas turbine and, where appropriate, driven equipment and for extended operation during purge and gas turbine compressor cleaning cycles. Where failure to accelerate at the correct rate can lead to hazardous situations not covered by other controls, for example flame or temperature monitoring, the speed shall be monitored and hazardous deviations shall automatically trip the gas turbine.

Starter systems (including gas pressurized or internal combustion engine driven systems) shall be protected by design or by the use of additional controls against overspeed conditions.

Where electric starter motors are intended to operate above their continuous rating, suitable controls shall be provided to ensure that hazardous over-temperatures do not arise.

If a separate, dedicated, starting driver that does not run continually with the driven gas turbine rotor is installed, it shall disengage and shut-down automatically before reaching its maximum tolerable speed. Failure to disengage shall automatically trip the gas turbine.

Starting systems using pressurized flammable gas as the source of power shall be designed to prevent associated fire and explosion hazards. The gas supply shall be isolated effectively when the starter is not in use, to the same level of tolerable risk as a gas fuel supply (see 5.10.5). Means shall be provided to enable gas to be purged from the starter system for maintenance purposes. Where the gas starter is not vented separately to atmosphere, precautions shall be implemented to prevent over pressure and reverse flow to the starter motor (see 5.22.2).

For safety and environmental reasons, the use of pressurized flammable gas starting systems is not recommended.

A filter/strainer shall be fitted in the supply to gas driven starter systems. It shall prevent any contaminants that can cause damage to the motor, leading to premature failure with the potential for loss of containment and/or ignition, from entering the motor or system components. The dew point of any gas supply shall be such that the formation of liquid hydrocarbons which can cause a motor malfunction or a hazardous situation at the vent discharge are eliminated.

In the event of a starter motor rotor failure, the starter motor casing should be capable of containing the release of high-energy debris. If this capability does not exist, then other safeguards shall be provided to protect personnel from injury (e.g. enclosure access prevented during starter operation).

For starting systems having common starting capabilities for multiple units, proper electrical and mechanical interlocks shall be provided and tested prior to commissioning in order to avoid starting the wrong gas turbine.

#### **5.8.19 Low ambient temperature conditions**

Where low ambient temperatures can exist during storage, transportation, handling, start-up and/or running conditions, which have the potential for causing premature failure of equipment and/or brittle fracture of structures, appropriate materials shall be used or protective measures shall be taken to prevent a hazardous situation.

Precautions shall be taken to prevent premature failure of the gas turbine compressor components that can be subject to malfunction caused by low inlet air temperature conditions.

### **5.9 Gas turbine compressor air inlet system**

#### **5.9.1 General**

The gas turbine air inlet system conditions and directs the air into the gas turbine compressor.

#### **5.9.2 Inlet air contamination**

Air inlet filtration shall be provided that minimizes the entry of atmospheric contaminants, airborne contaminants from adjacent plant and saliferous atmospheres, where necessary, that can lead to premature failure of gas turbine components, creating a hazardous situation.

The air inlet filtration system shall be capable of experiencing pressure changes due to credible turbine compressor surge events to ensure that a tolerable level of risk is maintained.

#### **5.9.3 Icing monitoring and prevention**

Where site conditions of temperature and humidity can be reasonably foreseen to cause icing at the gas turbine compressor inlet system, which can cause a dangerous situation, appropriate measures shall be taken to prevent the accumulation of hazardous quantities of ice, or controls utilized that initiate a trip before a hazardous situation is created. Where the measures for preventing inlet icing become inoperable and the gas turbine system is operating in the range of temperature and humidity where ice in the compressor inlet can form, the gas turbine should be shut-down when a hazardous situation is reasonably foreseeable.

Where compressor bleed anti-icing systems distribute hot air over the inlet openings or in the inlet duct, access shall be restricted in the vicinity of the hot air outlets during operation of the system.

Monitoring instrumentation shall be installed in such a manner that icing conditions shall not adversely affect the accuracy of the monitoring method. Instrumentation piping shall be routed so that inclusion of atmospheric condensates is prevented.

Where an evaporative cooling system or a direct water mist system is used at the gas turbine compressor inlet, the water supply shall be shut-off when air temperature monitoring at the gas turbine compressor inlet indicates that conditions exist for ice formation, which can lead to gas turbine compressor damage, resulting in a hazardous condition.

Where either on or offline water wash is installed, appropriate precautions shall be taken to prevent the formation of ice. Such precautions may include the use of a suitable anti-freeze agent (see 7.5.2 and 5.24.2).

#### 5.9.4 Implosion protection

Where an implosion flap door is provided in the inlet system to open at a specific pressure drop to prevent implosion of the inlet ducting with the potential for the ingestion of dangerous foreign objects if an upstream blockage occurs, suitable measures shall be taken to prevent foreign object ingress at the bypass door, which, due to the size of the object, could cause a dangerous situation. Measures shall be installed to ensure that the implosion flap door, where provided, cannot become frozen shut where its failure to operate can cause a dangerous situation.

#### 5.9.5 Inlet explosion protection

The combustion air intake shall not be located in a zone 0 or zone 1 area (see 5.16.2). Location in a zone 2 area shall be considered acceptable only where an assessment indicates that the largest credible leak from a secondary source would be diluted to such an extent by the combustion air that a hazardous situation would not arise.

Gas detector(s) to initiate a gas turbine trip shall be located at the gas turbine compressor air inlet where a zone 2 area exists from a credible leak, as described above, or where there is still the potential for flammable gases or vapours to enter the gas turbine compressor air inlet from either:

- a) adjacent plant, should there be an uncontrolled event or major incident, or
- b) the atmosphere, due to excessive venting or similar uncontrolled conditions [e.g. in natural gas or liquefied petroleum gas (LPG) plants], or
- c) ingestion of unburnt flue gas.

Where such risks exist gas detector(s) and any other equipment located in the combustion air stream shall be suitably certified for use in the zoned area.

Gas detectors and associated alarm systems shall comply with 5.19 and be selected taking into account the speed of escalation of any reasonably foreseeable leak source, the response rate of the detector(s), the system time constants and any other relevant factors.

#### 5.9.6 Waste disposal through combustion

In some applications the combustion inlet air may be deliberately mixed with waste flammable gases, vapours or aerosols to eliminate such substances from the environment. The supply of the waste products shall be controlled and shut-off during the gas turbine start-up cycle and prior to shut-down. The allowable flow rate and concentration of the waste flammable gases, vapours or aerosols prior to mixing with the combustion air flow, and the temperature and pressure of combustion shall be monitored and controlled within limits verified as tolerable by detailed analysis and tests. If the flow rate or concentration exceed the defined levels, the supply shall be terminated.

Where this disposal process is adopted suitable gas detector(s) shall be installed at the gas turbine compressor air inlet as an additional precaution to trip the gas turbine in the event of an excess waste flow. Gas detector(s) shall comply with 5.19 and be selected taking into account the speed of escalation of the flammable content of the waste stream, the detector response rate, the system time constants and any other relevant factors.

### 5.9.7 Recirculation

If ventilation outlet air from the gas turbine enclosure is used for anti-icing at the gas turbine compressor air inlet there is the risk that a potentially explosive mixture of fuel and air can be ingested into the gas turbine if there is a fuel leak within the gas turbine enclosure.

Where this risk exists, the following safety precautions shall be taken or the air shall be heated by other means (e.g. indirectly):

- a) Gas detector(s) shall be located in the gas turbine compressor air inlet plenum and in the gas turbine enclosure ventilation-air outlet; and
- b) All equipment within the ventilation air and combustion inlet air flows shall comply with 5.16 for use in zone 2; and
- c) All surface temperatures within the ventilation and combustion inlet air flows shall not exceed the AIT of any flammable substances that may be present (see 5.16.4.4); and
- d) The gas detector(s) and associated safety systems response times shall prevent a potentially dangerous explosive mixture from reaching the anti-icing outlet within the gas turbine compressor air-inlet plenum based on a sudden fuel leak within the enclosure at the minimum ventilation flow rate.

Where gas turbine compressor delivery air is piped to the gas turbine compressor inlet system to control exhaust emissions during operation under partial load, the take-off point, controls and piping design shall prevent excess flow occurring, the accumulation of unburnt hydrocarbons and the potential for burnt/unburnt products of combustion entering the inlet and causing a hazardous situation on flameout or gas turbine compressor surge.

### 5.9.8 Gas turbine compressor air inlet ducting

The gas turbine compressor air inlet ducting shall normally be routed to avoid hazardous areas. Where this is not possible, the ducting integrity shall prevent unacceptable leakage paths.

The air inlet ducting system shall be capable of experiencing pressure changes due to credible turbine compressor surge events to ensure a tolerable level of risk is not exceeded.

## 5.10 Fuel systems

### 5.10.1 General

The fuel system shall be considered to include all components from the manually operable shut-off valve up to and including the burners. The most common fuels used by gas turbine applications within the scope of this International Standard are natural gas and liquid fuels. However, a wide range of alternative fuels can be used and others are under consideration or trial. Risk assessment shall take the relevant properties of the fuel into account.

### 5.10.2 Fuel supply quality and supply conditions

Manufacturers shall provide detailed fuel specifications (including dew point margins for gaseous fuels and potential for wax formation) and condition ranges required for safe, reliable operation of their machines to the operator and to the designer of the fuel supply system. When the fuel does not comply with the detailed fuel specification the operator shall provide a fuel analysis (including up to C12 for gas fuels) so that the manufacturer can specify the specific fuel treatment necessary to mitigate any associated risks to a tolerable level. Treatment may include varying degrees of pressure and flow control, filtration, condensate removal or heating of the fuel supply. The operator has the responsibility to ensure that the supplied fuel composition remains within the range of the agreed fuel specification throughout the lifetime of the plant, unless a deviation is formally agreed with the manufacturer.

Particular attention shall be given to the dew points and release of liquid hydrocarbons or water for gas fuels, and to wax formation at low temperatures for liquid fuels.

Attention should also be given to any trace element content likely to lead to an unacceptable reduction of metallurgical properties.

### **5.10.3 Pressure testing**

Where it is not practical to conduct a final assembly pneumatic or hydrostatic pressure test on the piping connected to the combustion system, a safe commissioning procedure shall be adopted to check for leaks on the running gas turbine. The procedure adopted shall be shown to achieve a tolerable level of risk and shall be appropriately documented.

### **5.10.4 Fuel supply heating**

Electrically powered heaters or any alternative means shall be assessed for safety for use with the proposed fuel specification. Overheat protection shall be provided to ensure that excessive heat input to the fuel cannot occur.

Where heat exchangers use fluid media as the heat input, and fuel leakage followed by entrainment into the media can cause a dangerous situation, protective measures shall be taken. The potential for such leakage shall be minimized by detailed design.

Flame fired direct heating shall not be used. Where trace heating or comparable means are used, the design shall self-limit the temperature, or control thermostats shall be used.

### **5.10.5 Gas fuel systems**

#### **5.10.5.1 General**

As a minimum, each gas fuel supply shall include the following functions:

- a) manual isolation (see 5.10.5.2); and
- b) leak tight shut-off (see 5.10.5.4); and
- c) automatic fast acting shut-off (see 5.10.5.4); and
- d) flow control (see 5.10.5.3); and
- e) venting for depressurization between leak tight and automatic fast acting shut-off valves (see 5.10.5.4); and
- f) venting for pipework depressurization (see 5.10.5.4 or 5.10.5.5).

Additional equipment shall be provided where a system risk assessment of all reasonably foreseeable conditions and the reliability of the equipment used indicates that additional control is required.

Where the gas fuel supply system comprises more than one supply or a single supply is divided for multiple use, equipment in each supply shall be duplicated such that the individual supplies comply with 5.10.5.

A strainer shall be fitted in accordance with 5.10.5.6 where necessary for safe operation.

Figure 1 a) shows the minimum arrangement and indicates the operation of the valves. Figure 1 b) and c) show typical alternative arrangements.

**NOTE** National regulations may require certification of safety shut-off valves and vent valves.



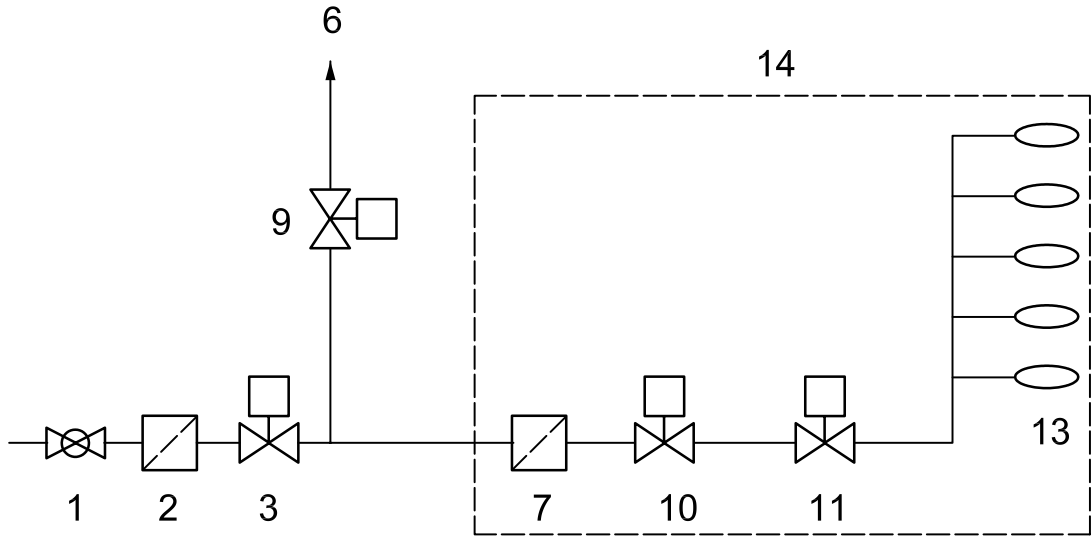

1 a) Minimum arrangement

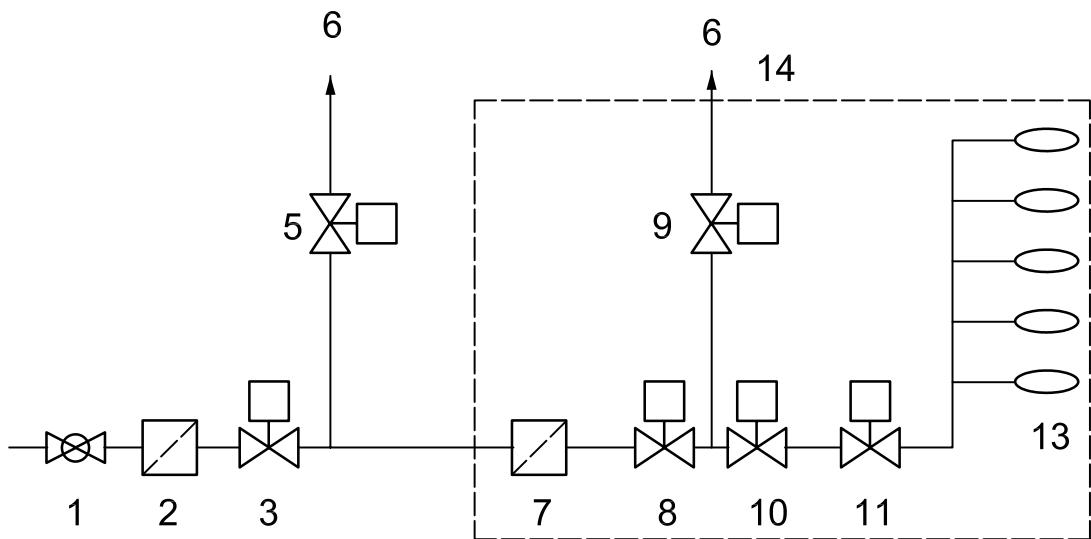

1 b) Typical alternative arrangement

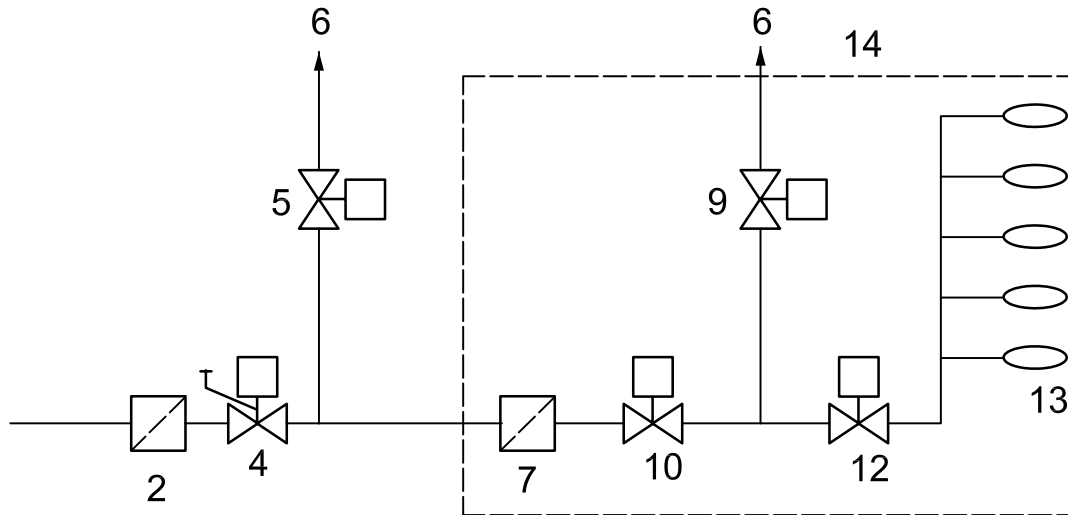

1 c) Typical alternative arrangement

**Key — Type of equipment**

- |   |   |    |   |
|---|---|----|---|
| 1 | manual isolation valve                    | 8  | shut-off valve <sup>a</sup>                       |
| 2 | strainer, optional                        | 9  | vent valve <sup>b</sup>                           |
| 3 | shut-off valve                            | 10 | automatic fast acting shut-off valve <sup>a</sup> |
| 4 | shut-off valve and manual isolation valve | 11 | flow control valve                                |
| 5 | vent valve                                | 12 | flow control and shut-off valve <sup>a</sup>      |
| 6 | vent                                      | 13 | combustion system                                 |
| 7 | strainer, optional position               | 14 | typical gas turbine enclosure or building limits  |
- <sup>a</sup> Close on every shut-down.  
<sup>b</sup> Vent on every shut-down.

**Figure 1 a), b) and c) — Gas fuel system**

Leak tight and automatic fast acting shut-off valves shall fail closed by permanent available energy, e.g. spring force. The fail-safe status of vent valves shall minimize any risks. All valves should be specified such that a tolerable level of risk and reliable operation will be achieved under all reasonably foreseeable operating conditions.

Normally, automatic shut-off valves should not be energized to open until the associated downstream vent valve has been proved closed.

Vent valves and associated pipework shall be sized to ensure that the depressurized pipe remains at atmospheric pressure taking into account the potential for leakage in upstream valves.

Integral valve combinations may be used providing the necessary functional safety is achieved without introducing additional risk.

See 5.11.2 relating to fuel control during ignition.

**5.10.5.2 Isolation**

For operation during maintenance activity or by fire service personnel, a valve, which can be manually operated, shall be fitted to the inlet of each gas turbine installation upstream of the automatic valves. This valve shall be clearly marked, located in an accessible position and should be capable of being operated by an acceptable level of physical force.

NOTE Guidance on the physical strength for the hand-operation of equipment is given in EN 614-1:2006.

### 5.10.5.3 Flow control valve

The fuel flow control valve shall be specified and positioned to control the fuel flow to the gas turbine under all reasonably foreseeable operating conditions.

Where failure of fuel flow control equipment can lead to excess fuel flow or other dangerous conditions, an additional independent device or devices shall ensure tolerable fuel flow to the gas turbine. Alternatively, the position of the control valve shall be monitored and if an “out of position to demand” is detected, a shut-down shall be initiated.

### 5.10.5.4 Shut-off valves and associated vent valve

Shut-off of the gas fuel supply shall be performed by two independently operated automatic shut-off valves; the piping between the valves shall be vented. At least one of the two shut-off valves shall be an automatic fast acting shut-off valve and one shall be a leak tight valve, both of which shall be specified and positioned so that the fuel supply to the gas turbine will be shut-off in the event of a dangerous situation at a rate that will prevent dangerous failure of the gas turbine. One of the two shut-off valves may serve as a flow control valve. This shall not be the automatic fast acting shut-off valve, which shall be provided as an independent function.

Upon shut-down, both shut-off valves — Figure 1 a), key items 3 and 10; Figure 1 b): key items 8 and 10, and Figure 1 c): key items 10 and 12 — shall be closed and the automatic vent valve opened — Figure 1 a), b) and c): key item 9 — to create atmospheric pressure in the supply line to eliminate the possibility of fuel entering the gas turbine in its shut-down condition.

Where the design of the fuel system is such that the flow of fuel to the gas turbine requires further reduction, due to the stored energy in the piping system downstream of the automatic fast acting shut-off valve, an appropriately sized and positioned fast acting vent valve or alternative equipment shall be used to safely dissipate the stored energy.

### 5.10.5.5 Shut-off valve — Outside the gas turbine package

A shut-off valve shall be located outside the gas turbine enclosure or building limits, or in a separately enclosed gas fuel package at the interface of the enclosure or building, to automatically isolate the fuel supply to the gas turbine in the event of a dangerous situation. The associated vent valve can be located either inside or outside the gas turbine or gas fuel package to vent the section of the pipe between the shut-off valve and the automatic fast acting shut-off valve.

Where risk assessment indicates that there is the potential for loss of containment from high speed rotating equipment which can cause damage to the valves or rupture of the fuel supply pipe to the gas turbine, the shut-off valve(s) outside the gas turbine package and the supply pipe to the valves shall be located outside the zone where hazardous projectiles can occur from a potential failure of rotating equipment to ensure fuel shut-off can be achieved. Where the gas turbine package is located in a building, the risk assessment shall consider whether the valves shall be located outside the building to provide additional isolation.

The fuel shut-off and the vent valve(s) shall be operated automatically on a gas turbine trip if

- a) a fire has been detected within the gas turbine fire protection area, or
- b) where risk assessment indicates that the cause of the trip can cause damage to or failure of the pipe between the valves and the gas turbine package, or damage to the equipment on the gas turbine package, either leading to the uncontrolled leakage of fuel.

### 5.10.5.6 Strainer

A strainer shall be installed upstream of any automatic fast acting shut-off valve at a suitable location to prevent valve malfunction due to debris entering the valve.

### 5.10.5.7 Valve proving and position monitoring

At start-up the position of valves necessary for shut-down shall be confirmed.

At shut-down the correct functioning of the automatic fast acting shut-off valve, the automatic leak tight shut-off valve and the automatic vent valve shall be automatically monitored to ensure that correct operation of the valves has been achieved.

The method used to monitor the correct function of the valves shall be determined by risk assessment. Where valve pressure proving is used additional equipment as appropriate may be installed to facilitate pressurization and pressure monitoring. Any additional valves shall be pressure proved as part of the proving sequence.

The requirement to monitor the closed position of the vent valve shall be determined by risk assessment taking into account the location of the vent outlet and the hazardous area created should the vent valve fail to close.

### 5.10.5.8 Venting — Not to atmosphere

Where, due to the toxicity of the gas, or where adequate dispersion cannot be assured, or where environmental considerations prohibit venting to atmosphere, the gas vents may be piped to a low pressure [ $< 50$  kPa (0,5 bar)] flare stack, and additional precautions to prevent gas from entering the gas turbine shall be implemented. As a minimum this shall consist of a double block and vent in the supply line prior to the gas turbine, the valves of which shall be proved and monitored for leak tightness. The vent valve shall be closed after venting to form a double block between the vent line and the gas turbine and the pressure in the vented section of the line monitored for any pressure increase. If an increase in pressure is detected this shall be annunciated at the control system to enable rectification action to be taken.

## 5.10.6 Liquid fuel systems

### 5.10.6.1 Fuel control

As a minimum, each liquid fuel supply shall include the following functions:

- a) manual isolation (see 5.10.6.2); and
- b) flow control (see 5.10.6.3); and
- c) automatic fast acting shut-off (see 5.10.6.4); and
- d) leak tight shut-off (see 5.10.6.5); and
- e) spill and/or drain (see 5.10.6.4 and 5.10.6.6); and
- f) fuel pump (see 5.23.8.7).

Additional equipment shall be provided where a system risk assessment of all reasonably foreseeable conditions, and the reliability of the equipment used, indicates that additional control is required.

Different arrangements and combinations of devices may be utilized to fulfil the above functions provided the concepts described in 5.10.6 are achieved and the fuel can be shut-off at a rate that prevents dangerous failure of the gas turbine, and the possibility of fuel entering the gas turbine in its shut-down condition is eliminated.

Figure 2 shows a typical arrangement. Other arrangements or configurations are permitted.

Shut-off valves shall fail closed by permanent available energy, e.g. spring force. The fail-safe status of drain valves shall minimize any risks. All valves should be specified such that a tolerable level of risk and reliable operation are achieved under all reasonably foreseeable operating conditions.

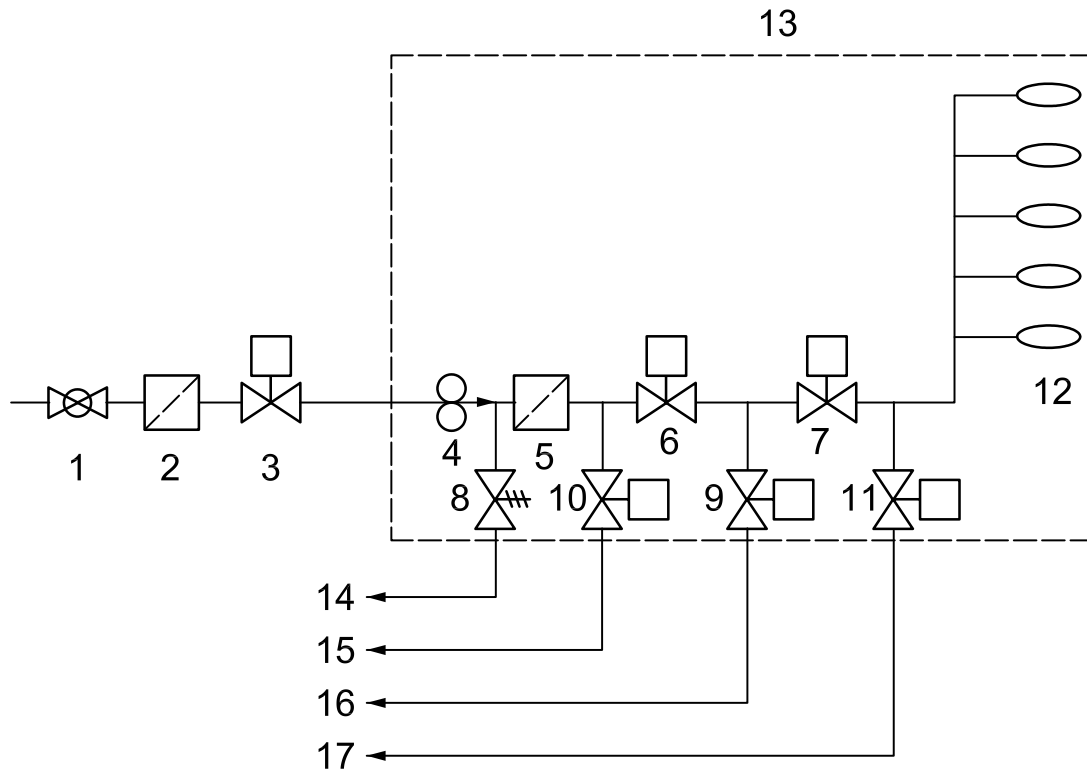

#### Key — Type of equipment

- |   |   |    |  |
|---|---|----|--|
| 1 | manual isolation valve                                  | 10 | spill valve — alternative location               |
| 2 | filter or strainer, optional position                   | 11 | drain valve <sup>b</sup>                         |
| 3 | leak-tight shut-off valve                               | 12 | combustion system                                |
| 4 | fuel pump, may be located outside gas turbine enclosure | 13 | typical gas turbine enclosure or building limits |
| 5 | filter or strainer, optional position                   | 14 | relief   |
| 6 | flow control device                                     | 15 | return to supply — alternative location with 10  |
| 7 | automatic fast acting shut-off valve <sup>a</sup>       | 16 | return to supply                                 |
| 8 | relief valve (See 5.23.8.7)                             | 17 | drain  |
| 9 | spill valve   |    |  |
- <sup>a</sup> Close on every shut-down,  
<sup>b</sup> Controlled operation on shut-down.

**Figure 2 — Typical liquid fuel system arrangement**

#### 5.10.6.2 Isolation

For operation during maintenance activity or by fire service personnel, a valve, that is capable of manual operation, shall be fitted to the inlet of each gas turbine installation upstream of the automatic valves. This valve shall be clearly marked, located in an accessible position and should be capable of being operated by an acceptable level of physical force.

NOTE Guidance on the physical strength for the hand-operation of equipment is given in EN 614-1:2006.

#### 5.10.6.3 Flow control device

The fuel flow control device shall be specified, located and governed to control the fuel flow to the gas turbine under all reasonably foreseeable operating conditions.

Where failure of fuel flow control equipment can lead to excess fuel flow or other dangerous conditions, an additional independent device or devices shall ensure tolerable fuel flow to the gas turbine. Alternatively, the position of the control valve shall be monitored and if an “out of position to demand” is detected, a shut-down shall be initiated.

#### 5.10.6.4 Automatic fast acting shut-off valve and spill valve

Shut-off of the liquid fuel supply shall be performed by two independently operated automatic shut-off devices. At least one valve shall be an automatic fast acting shut-off valve.

After operation of the shut-off devices and after any fuel purging, a valve shall drain a section of the supply line to eliminate the possibility of fuel entering the gas turbine in its shut-down condition. This valve shall be sized to ensure the drained pipe volume remains near atmospheric pressure taking into account the potential for leakage in upstream valves. Where a spill valve does not spill to atmospheric pressure a drain valve shall be supplied in accordance with 5.10.6.6. Operational requirements may require the liquid fuel system to remain pressurized when liquid fuel is not being furnished to the engine in order to minimize either starting time or fuel transfer. In these situations, any necessary design steps and risk assessment shall validate that this results in a tolerable level of risk.

Where spill flow is returned to the pump suction sufficient cooling and/or make-up flow shall exist to prevent overheating and the potential for vapour lock, or the fuel supply temperature before the pump suction should be monitored and a shut-down initiated if overheating occurs.

#### 5.10.6.5 Leak tight shut-off valve — Outside the gas turbine package

An automatic shut-off valve shall be located outside the gas turbine package to automatically isolate the fuel supply to the gas turbine in the event of a dangerous situation (see Figure 2, key item 3).

Where risk assessment indicates that there is the potential for loss of containment from high speed rotating equipment that can cause damage to the valves or rupture of the fuel supply pipe to the gas turbine, the shut-off valve(s) outside the gas turbine package and the supply pipe to the valves shall be located outside the zone where hazardous projectiles can occur from a potential failure of rotating equipment, to ensure that fuel shut-off can be achieved. Where the gas turbine package is located in a building the risk assessment shall consider whether the valve shall be located outside the building to provide additional isolation.

The valve shall be operated automatically on a gas turbine trip if

- a) a fire has been detected within the gas turbine fire protection area, or
- b) where risk assessment indicates that the cause of the trip can cause damage to or failure of the pipe between the valves and the gas turbine package, or damage to the equipment on the gas turbine package, with either leading to the uncontrolled leakage of fuel.

#### 5.10.6.6 Drain valve

Where required to achieve a tolerable level of risk during shut-down and where the spill valve does not spill to atmospheric pressure, an automatic drain valve shall be installed to drain fuel downstream of the automatic fast acting shut-off valve which shall operate on every shut-down to drain liquid. The valve may be closed during periods of shut-down where other risks are mitigated.

Where a drain valve is used to drain a part of the system which on shut-down is subject to the reverse flow of high pressure and temperature gas turbine compressor delivery air capable of causing the ignition of any hydrocarbons in the drain or purge lines, the drain sequence shall be controlled to prevent this condition. Alternatively cooling and/or a flame arrester shall be used to prevent any ignition escalating outside the gas turbine package or a separator mechanism shall be used to vent any hot gases to atmosphere whilst draining fluids to a waste liquids tank.

If there is the potential for reverse flow from the tank, appropriate devices and/or instrumentation shall be installed to provide protection against reverse flow into the gas turbine under all reasonably foreseeable conditions.

#### 5.10.6.7 Filter/Strainer

A filter/strainer shall be fitted upstream of the fuel flow control device and automatic fast acting shut-off valve at a suitable location to prevent device or valve malfunction due to debris entering the device or valve.

#### 5.10.6.8 Valve proving and position monitoring

At start-up the position of the valves necessary for shut-down shall be confirmed.

At shut-down the correct function of the automatic fast acting shut-off valve, the automatic leak tight shut-off valve and the automatic drain valve shall be monitored to ensure that correct operation of the valves has been achieved.

The method used to monitor the correct functioning of the valves shall be the subject of risk assessment. The requirement to monitor the position of the drain valve, where supplied, shall be the subject of risk assessment, taking into account the location of the drain outlet and the hazard that can be created should the valve malfunction.

#### 5.10.6.9 Thermal relief

Where the potential exists for a liquid to be trapped between closed leak tight valves a suitably located thermal relief shall be provided in accordance with 5.23.9.3.

#### 5.10.7 Multi-fuel systems

It shall not be possible under any condition for the reverse flow of fuel into any other system to occur, where this can lead to danger. Appropriate precautions shall be taken to ensure that liquid fuels cannot enter the gas-fuel system where gas fuel is used to purge the liquid fuel burners.

Where only a single fuel can be fired at any one time, interlocks shall be provided to ensure that the standby fuel system cannot operate or is isolated.

Where more than one fuel can be fired at any one time, it shall be assured that excess energy input due to over-fuelling cannot occur in the gas turbine.

#### 5.10.8 Fuel purging

Where forward and reverse purge/drain sequences are used during start-up, operation, or shut-down, risk assessment shall be carried out taking into account all reasonably foreseeable risks including but not limited to the following:

- a) failure of reverse purge sequence during shut-down, which can leave low auto-ignition temperature fuels in the feed lines with the potential for uncontrolled ignition on a restart;
- b) inadequate draining of liquid fuel after a false start, which can leave liquid fuel in the drain lines with the potential for uncontrolled ignition on restart;
- c) uncontrolled shut-down whilst running on low auto-ignition temperature fuel, causing purge sequences to fail;
- d) potential for ignition of vapours in the purge drain lines/vent tank(s) due to the temperature of the reverse-purge combustion air;

- e) contamination of liquid fuel storage with alternative low auto-ignition fuels if a purge/drain sequence fails, with the potential for uncontrolled ignition on restart due to contamination of the fuel used for starting;
- f) potential for vapour lock (change of state resulting in increased volume and pressure);
- g) uncontrolled supply, venting or draining of dangerous media;
- h) presence of condensates at low points.

Risk mitigation measures such as the use of appropriate instrumentation, double block and vent valves, valve position monitoring, prevention of reverse flow, separation of media, flame arresters, etc., shall be considered.

### 5.10.9 Fuel drainage

Where liquid fuel is used suitable drain points shall be incorporated to drain off unburnt fuel from the pressure section of the casing and/or exhaust system (e.g. in the event of a flame failure on start-up). The drain points shall have valves, preferably automatically operated, that open on shut-down and close as part of the start sequence. If manual valves are used clear instructions shall be given on their operation. The start cycle shall provide a sufficient period to allow draining of this unburnt fuel prior to initiating a restart by the use of automatic drain valves. Automatic or manual operation of the valves as well as their operating schedule, their fail-safe position, the monitoring of the effectiveness of the drain or of the valve position and the requirement of a pre-start purge shall be determined on the basis of risk assessment, taking into account the risk of uncontrollable overspeed caused by burning undrained fuel during start-up, hot gas entering the drain system during operation and unburnt gaseous fuel and air mixtures entering the drain system.

## 5.11 Combustion supervision

### 5.11.1 General

Monitoring functions shall be provided for the purposes of detecting that combustion is established at start-up and that a failure of combustion is detected during operation. Both direct and indirect flame sensing systems shall ensure that flame is not sensed prior to the burner ignition sequences.

Where indirect flame monitoring is used, derived from the gas turbine temperature, pressure, speed parameters or reverse load, these values shall be verified by testing to correctly detect both combustion and loss of combustion under all reasonably foreseeable operating conditions.

Both direct and indirect flame monitoring systems shall either have the ability to be periodically tested, e.g. at start-up and shut-down, or to be self diagnosing or proven automatically during operation.

If air and gas fuel is mixed upstream of the combustor, the risk of unintended ignition in the system causing a dangerous failure shall be assessed and reduced to a tolerable level.

### 5.11.2 Requirements for ignition

Gas turbine combustors, except reheat combustors based on auto-ignition, shall have at least one igniter and one main burner. The igniter may consist of a simple electrical (spark) igniter or of an igniter and ignition system (ignition flame), or of an ignition system with cross-fire tubes. The main burner may contain a pilot burner (pilot flame) as part of the main burner (main flame).

The energy released during the ignition safety time shall be limited and the maximum pressure rise from a delayed ignition shall not cause unacceptable damage to the plant. The ignition safety time shall be determined by risk assessment. Failed starts with liquid fuels shall be followed by a drain cycle. Failed starts with gaseous fuels where not followed by a re-start attempt require an exhaust purge unless it is indicated as unnecessary by risk assessment. See also 5.12.4.



The requirements for enclosure purging in 5.13.6 and gas turbine and exhaust purging in 5.12.4 shall be satisfied prior to ignition (characterized by the occurrence of the first ignition spark). Igniters shall be energized prior to fuel being admitted to the combustion system.

Overfueling during ignition shall be prevented (e.g. by control valve position, pressure or exhaust temperature monitoring or fuel flow monitoring).

### 5.11.3 Extinction safety time

On loss of flame, the flame detection and fuel shut-down system shall have a combined maximum response time less than the extinction safety time to limit the release of unburned fuel to an amount that prevents dangerous consequences.

## 5.12 Exhaust system

### 5.12.1 Damper controls

If exhaust dampers are fitted, controls shall be provided to detect uncontrolled damper closure and to shut-down the gas turbine before an overpressure condition can arise. Where rapid closing of dampers can create excessive exhaust pressures leading to a hazardous situation, the closing speed of the dampers shall be limited unless other suitable methods are applied that achieve a tolerable level of risk.

### 5.12.2 Flexible joint location

Where possible, flexible exhaust joints shall not be situated close to walkways or to any electrical or instrument cable or hydrocarbon pipework where leakage or radiation or the potential temperature increase can lead to a hazardous situation. Where the above is not possible, the flexible joints shall be shielded.

### 5.12.3 Exhaust stack

The height of exhaust outlets shall be sufficient to provide adequate dispersion of all emissions and the design shall take into account the potential, under reasonably foreseeable operating conditions, for large amounts of oxygen depleted air, carbon monoxide or other hazardous air pollutants being emitted that can cause the asphyxiation of personnel in the area of an inadequately dispersed exhaust. The emissions shall not cause a nuisance or danger to nearby persons or property.

NOTE National or local regulations can govern stack heights.

The exhaust design and location shall take into account wind, seismic hazards, hazardous areas, vent outlets and other site environmental criteria, and shall accommodate the location of adjacent equipment or structures that can be adversely affected by high exhaust gas temperatures. The design should consider internal pressure levels that can occur as a result of improper engine operation.

In areas where personnel can be in proximity to the exhaust ducting/stack, thermal protection shall be provided, either as an integral part of the design or through remedial application.

Safe access shall be provided so that regular checks for leaks can be undertaken on exhaust ducting and exhaust flexibles where these are routed through a building where leakage, due to the above, can lead to asphyxiation or poisoning of personnel in or passing through the building. (See 7.5.2.)

### 5.12.4 Explosion protection

Where the potential exists for the exhaust system to contain an explosive atmosphere, or gases or vapours that can create an explosive atmosphere, the exhaust system shall be purged before gas turbine start-up. The purge flow rate should be sufficient to minimize unpurged voids. At least three complete volume changes of the gas turbine and downstream exhaust system equipment shall be undertaken. The volume is measured up to the base of any main chimney or to that point where, under all load conditions, the exhaust gas temperature of any flammable gases or vapours that can be present is below 80 % of the AIT, measured in degrees Celsius (see 5.16.4.4). Attention shall be given to the potential for entrainment/re-entry/collection of heavier-than-air gases.

Exhaust purging should be achieved by rotating the gas turbine compressor, by the use of separate, suitably controlled fans or by a combination of both to achieve the required volume changes in the total system that may be subject to exhaust gas temperature above the AIT (see 5.16.4.4) of any flammable gases or vapours that can be present. The gas turbine exhaust gases can be used for purging provided that they are proven and controlled to be less than 80 % of the AIT measured in degrees Celsius of any flammable gases or vapours that can be present. Additional requirements can be necessary for purging the downstream plant and any associated firing equipment.

The required air purge volume shall be proven by the use of appropriate instrumentation interlocked to the start-up sequence. Where the gas turbine air compressor itself is used to provide the purge flow, proof of adequate gas turbine compressor rotation speed and proof of correct variable guide vane and/or compressor bleed valve positions shall be used to verify the flow rate.

In the case of a normal controlled shut-down where a shut-off valve operating check has been undertaken and a subsequent start-up takes place, start-up without a full purge may be undertaken, subject to risk assessment to ensure that no fuel can enter the gas turbine or exhaust system.

The fuel used for start-up shall be such that auto-ignition on hot internal surfaces does not lead to dangerous overpressure conditions or uncontained component failure. This typically applies to fuels such as naphtha where significant potential exists for the formation of large potentially explosive vapour clouds.

Where more than one gas turbine supplies a heat recovery system, precautions should be taken to ensure that reverse exhaust gas flows cannot pass back into another gas turbine under any purge, start-up or other flow condition.

## **5.13 Enclosures**

### **5.13.1 General**

Outdoor enclosures shall be constructed so that the level of weather protection achieved ensures that the correct operation of safety equipment is not impaired by environmental conditions or influences. See 5.25 for installation of enclosures in hazardous areas.

Where the enclosure is protected by a gaseous fire extinguishant the seals at retained panels, doors and other closure points shall withstand any increase in pressure caused during the release of the extinguishant and maintain the concentration of the extinguishant in accordance with the fire extinguishing code or standard that has been adopted (see 5.15.6).

Non-metallic materials used for flexible connections and seals shall be selected to withstand the loading and environmental conditions to which they are subjected, without impairing the effectiveness of gaseous extinguishant and cooling or dilution ventilation.

Where there is the potential for leakage from driven machinery, of gases of subgroup IIC of IEC/TR 60079-20:1996 (e.g. hydrogen cooled generators) or vapours or mists where the AIT (see 5.16.4.4) is less than the gas turbine surface temperature, the machinery shall not be installed in the same enclosure as the gas turbine unless a gas tight dividing wall or an air gap between two dividing walls is provided, or other equally effective means shall be provided to prevent such gas or vapours from entering the gas turbine enclosure.

### **5.13.2 Enclosure structure**

The structure of enclosures, attached panels, doors and their latches shall be designed to withstand the following:

- a) reasonably foreseeable environmental loading associated with the location;
- b) pressure loads caused by the operation of the ventilation system, gaseous extinguishant systems and machinery vents/bleed valves and blockage of ventilation outlets;

- c) overpressures caused by any reasonably foreseeable rupture or leaks from pressure casings and pressurized ducting;
- d) overpressure prior to pressure relief where the requirements of 5.16.5.2 are being implemented or overpressure up to 1 000 Pa (10 mbar), unless extrapolated to 1 500 Pa (15 mbar), where the overpressure is being limited in accordance with 5.16.5.3.

The enclosure structure should include attachments and integrated tools necessary to allow maintenance activities to be carried out safely in conjunction with the supply of any special maintenance tools.

### 5.13.3 Enclosure fire precautions

#### 5.13.3.1 General

The risk of fire shall be assessed in all enclosures and, where necessary, fire precautions shall be implemented in accordance with 5.15.

#### 5.13.3.2 Gas turbine enclosure

An integrated fire protection system, including fire detection and suppression equipment, together with the necessary controls and instrumentation shall be provided in the gas turbine enclosure in accordance with 5.15. The system shall be able to detect fire automatically, directly or indirectly, and extinguish it reliably.

### 5.13.4 Explosion prevention and protection — Area classification — Ventilation

Hazardous areas within the enclosure shall be classified and explosion prevention and protection measures shall be implemented in accordance with 5.16. Where flammable gases, vapours or mists that have an AIT below the temperature of any exposed hot surface can be present or where risk assessment indicates a residual risk of ignition, the additional measures described in 5.16.5.2 (explosion relief) and/or 5.16.5.3 (pressure resistant design) and/or 5.16.5.4 (suppression) shall be implemented.

#### 5.13.5 Gas detection

Where an enclosure contains hazardous zones due to flammable gas or vapour, gas detection shall be implemented in accordance with 5.19.

#### 5.13.6 Enclosure purging

Where an enclosure contains equipment that can release gases and liquids capable of producing flammable vapours and mists, the enclosure and associated upstream and downstream ducting volume shall be subject to a purge cycle prior to start-up unless the ventilation has run continually since previous operation of the gas turbine.

The purge cycle shall be sufficient to displace three times the volume of the ventilated system.

To shorten the duration of fire or explosion risk in comparison to a natural cooling cycle, the ventilation system shall normally continue to operate at shut-down to reduce the surface temperature of any surface to less than 80 % of the AIT, measured in degrees Celsius (see 5.16.4.4), of any combustible fluids and gases. A margin shall be made, where applicable, for the effects of heat soak from hot masses internal to the surfaces.

In the case of loss of ventilation during the cool down cycle the actions related to the loss of ventilation shall occur. See 5.16.2 and 5.21.9.

#### 5.13.7 Mist detection

Flammable mist can be formed from pressurized fluid leakage at a temperature below the flash point of the fluid (see 5.16.2.). If risk assessment indicates that the conditions exist for an explosion in an enclosure from the ignition of an explosive mist/air mixture, such that additional risk reduction measures are necessary, a liquid mist detection system may be installed. Detectors should be located taking into account their suitability for operation under local conditions of temperature and air velocity. Alarm settings shall be set as low as possible, commensurate with the avoidance of spurious detection.

### 5.13.8 Access and doors

To prevent operator entrapment, if it is physically possible for operators to gain entry, each access door shall be fitted with an internal release mechanism that overrides any locking mechanism and is capable of being opened against negative pressure ventilation forces. See 7.6 for information to be supplied in relation to access.

NOTE Similar considerations may apply to hatches.

Enclosure doors shall be fitted with devices when required to prevent unexpected movement due to wind or other actions that can lead to impact or crushing hazards. Where high positive or negative pressure exists in artificially ventilated enclosures which can lead to uncontrolled movement the manual instructions shall contain procedures for safe opening and closing (see 7.6.1).

For fire extinguishant isolation refer to 7.6.1 for isolation details prior to personnel entry.

### 5.13.9 Entrapment

The arrangement of equipment within enclosures shall be such that access for reasonably foreseeable purposes is available without the risk of entrapment.

Account shall be taken of the need for emergency escape routes inside the enclosure to avoid trapping personnel in the event of a hazard.

## 5.14 Lighting

An appropriate level of local lighting shall be provided in areas where visibility is required for safe execution of operational activities. Emergency lighting shall be provided where illumination is required for safe operation (stand-by lighting) and escape (escape route lighting).

NOTE Guidance on emergency lighting can be found in EN 1838:1999 and NFPA 101:2003.

## 5.15 Fire precautions

### 5.15.1 General

A risk based approach to the requirement for fire risk reduction, protection, detection and suppression measures shall be taken based on the requirements of ISO 19353:2005, or an equivalent national standard providing equivalent requirements, taking into account the existence of a fire hazard, the probability of its occurrence and the degree of possible harm. The fire protection system shall be based on an integrated set of standards and the guidance described in 5.15.2 to 5.15.13 inclusive.

### 5.15.2 Structural fire risk reduction

The materials of construction of enclosed spaces where a fire risk exists, their associated structural members and any acoustic and thermal insulation shall be of non-combustible fire resisting materials to reduce fire loads and inhibit the spread of a fire. The use of small parts that are not connected, such as gaskets made out of combustible materials, is acceptable.

Materials used within evaporative inlet air coolers should be non-combustible.

Fire hazards of electrotechnical products shall be assessed in accordance with IEC 60695-1-1: 1999.

Where risk assessment indicates that a fire extinguishant system shall be provided, the enclosed space shall be designed with the objectives of containing the fire for the maximum period before detection can be assured, overcoming extinguishant delays and achieving a concentration of extinguishant to extinguish the fire.

### 5.15.3 Hydrocarbon fire risk reduction

#### 5.15.3.1 General

Tanks containing hydrocarbons shall be equipped with level monitoring equipment for leak detection and, where applicable, detection of over filling.

When defining the fire protection measures for gas fuel areas and other areas containing pressurized hydrocarbons, the actuation of the extinguishing measures (manual or automatic) shall initiate the automatic shut-off of the fuel supply (see also 5.13.3.2). Where manual actuation of the emergency release is required at the extinguishant containers, the operation manual shall advise that the emergency stop button shall be activated to cut off the fuel supply.

Pressurized equipment containing gas fuel, liquid fuel or other flammable hydrocarbons with the potential for forming flammable mists due to high pressure leaks, shall, in addition to the requirements of 5.23, be designed with the minimum number of connections required for correct assembly and maintenance. Where a leak can impinge on electrical equipment which can be a source of ignition, or a hot surface with a temperature above the AIT (see 5.16.4.4) of the potential leak source, additional precautions should be taken to mitigate the potential for leakage and guard against impingement.

So far as possible, joints should be positioned so that leaks do not drip or spray onto electrical equipment or hot surfaces.

Where appropriate insulation materials shall be protected against the penetration of hydrocarbons.

The flammability properties of any fluids should be taken into account during risk assessment. For liquid fuels of low AIT, such as naphtha, segregation of risk areas and the use of explosion relief or other effective measures such as coalescers, spray retainers, etc. should be considered during risk assessment where additional mitigation is required due to the presence of hot surfaces.

#### 5.15.3.2 Lubrication and hydraulic systems

Where risk reduction measures against flammable oil mists in the presence of hot surfaces do not provide an adequate level of safety further mitigation shall be undertaken, e.g. by the use of fire resistant or non-flammable fluids. Oil system vents where oil mist can appear shall be fitted with a mist eliminator and routed away from hot surfaces. If vent line outlets are located near a potential ignition source they shall be provided with flame arresters.

#### 5.15.3.3 Post-shut-down lubrication

Where it is necessary to protect the gas turbine from damage after a fire shut-down, emergency lubricating oil systems may remain in operation to those areas requiring protection provided risk assessment indicates a tolerable level of risk.

### 5.15.4 Fire protection

Where indicated by 5.13.3 or 5.2, an automatic integrated fire protection system shall be provided, together with the necessary controls and instrumentation.

The design shall ensure the integrity and functionality of the fire protection system in the context of fast and reliable detection of fire, fast and reliable discharge after detection, fast and reliable extinguishing and suppression of fire with regard to personnel safety.

### 5.15.5 Fire detection

To ensure that fires are detected at an early stage, areas at risk shall be monitored with automatic fire detectors. Detectors shall be selected from the following types:

- a) smoke detectors;
- b) flame detectors;
- c) heat detectors.

Heat detectors shall always be present, in the event that flame detectors are blinded by smoke or mist, and used in combination with other detectors where risk assessment indicates that an additional level of detection is required.

The fire detection principles described in ISO/TR 13387-7:1999 or a national standard providing equivalent guidance shall be applied.

Manual push-button fire alarms shall be installed near the main escape routes from any enclosed spaces and at exits from buildings within which a fire protection system is installed. The alarm function may be integrated with the extinguishant release manual push-button at the enclosure.

The definition of areas that are equipped with fire detection or a fire detection and extinguishing system shall be based on risk assessment. At least the minimum number of detectors required for the area being protected shall be installed to provide a fire alarm signal and minimize false alarms to an acceptable level.

Where the location of a fire detector is such that the accuracy of detection could be affected by contamination of the sensing components, due to pollutants or substances in the local air stream or atmosphere, the detector type selected shall produce a fault signal if contamination is detected.

### 5.15.6 Fire extinguishing systems

Fire extinguishing systems shall be designed, installed and tested to the relevant standard as follows:

- a) ISO 6183:1990 or NFPA 12:2005 for CO<sub>2</sub> systems;
- b) ISO 14520-1:2000 or NFPA 2001:2000 for other gaseous systems;
- c) NFPA 750:2006 for water mist systems;
- d) NFPA 13:2002 for sprinkler systems and NFPA 15:2001 for water spray systems.

The extinguishing media shall be selected so as not to cause any damage to the safety related equipment within the enclosed space.

Risk of exposure of personnel to asphyxiants and other extinguishants that are potentially hazardous shall be minimized.

A suitable alarm should be incorporated into the fire protection control system to provide sufficient warning to people within an enclosed space to make their escape before the discharge of a hazardous extinguishant. The pre-discharge alarms shall provide a time delay of sufficient duration to allow for evacuation under "worst case" conditions.

Where the extinguishant has not been isolated prior to entry, attempted entry into an enclosed space protected by a potentially hazardous extinguishant shall sound an alarm locally and at the control panel.

Extinguishing systems capable of asphyxiation shall not be installed in or used to protect normally occupied spaces.

Means for mechanical isolation of extinguishing systems shall be provided. The isolation device shall be fitted with position monitoring interfaced to the turbine control system. Isolation shall be repeatedly annunciated at the control system.

Electrical isolation of the extinguishment release may be permitted for short-term entry in large spaces with easy means of egress. Isolation shall be repeatedly annunciated at the turbine control system.

Any air exhausts or air inlet openings into the enclosure should normally be fitted with an automatic closing damper. If openings are kept open during extinguishant release, this shall be taken into account in the extinguishant quantity calculation. When calculating the quantities of extinguishant for discharge, due consideration should be given to unavoidable leakage from the enclosed space. Where dampers are utilized the closing force shall be such to ensure closure of the damper under all reasonably foreseeable environmental and operating conditions. Where required to achieve a tolerable level of risk, damper position shall be monitored.

The extinguishant concentration shall persist effectively to prevent re-ignition by hot surfaces until other safety measures are available (e.g. local fire service). Where re-ignition or lack of site replenishment of extinguishant is a high risk, consideration shall be given to a multi-shot system or providing reserve extinguishant capability.

There shall be two independent discharge release methods:

- a) one automatic, after a signal from the detection system; and
- b) one manual, by push button(s) at predefined points near to the enclosed space. Manual release may use electrical assistance to initiate the discharge.

NOTE 1 Some national standards require additional methods for manual release.

Each different design of enclosure shall be subjected to a one-time full extinguishant discharge release type test, or a door fan retention test in conjunction with a functional test on the extinguishment system to ensure the applicable integrity/sealing is achieved.

Proper functioning of all related systems and the sealing of the enclosed space shall be checked on each installation. See also 5.23.13 in relation to the suitability of pipework.

NOTE 2 For an example of door fan retention test procedures, see ISO 9972.

### 5.15.7 Water mist extinguishant

Where a water mist extinguishant system is used and where a continual discharge system can cause damage to the gas turbine leading to premature failure, a pulsed release system that has been proven not to cause such damage may be used. The interval of pulsing shall be such as to extinguish the maximum credible fire and maintain continual protection against re-ignition.

The numbers and positions of the water mist nozzles shall be selected to provide an adequate effect of the extinguishing spray taking into account the actual geometry and access of the parts.

Suitable measures shall be taken to prevent icing of the system.

The water mist system shall be suitably type tested and validated.

Water mist nozzles shall be fitted with a suitable filter/strainer such that any reasonably foreseeable blockage of the discharge orifices by particulates is prevented. System materials shall be chosen to reduce the potential for blockage of orifices by corrosion deposits. Water quality shall comply with the manufacturer's recommendations.

### 5.15.8 Extinguishing system controls

Each fire protection and extinguishing system shall be equipped with a fire protection control system. This may be a local panel, may be integrated with the gas turbine control system or may be installed in the main control panel area.

The system shall be capable of the functions specified in Table 1.

**Table 1 — System functions**

Function	Implementation
Manual push-button release	Installed at predefined points outside an enclosed space. Use of this release shall not override the required pre-discharge alarm sequences.
Automatic release	Automatic release on fire detection.
Selector switch	The extinguishing system shall be able to be inhibited.  The use of electrical selector switches to isolate extinguishant release can give rise to a false sense of security when the manual release is still available and should not be used as an alternative to mechanical isolation.
Acoustic alarm	At enclosed spaces by horn or alarm sirens.
Visual alarm	At enclosed spaces with a high noise level (e.g. gas turbine enclosure) by red flashing lights.
Interface to turbine controls	Suitable contacts and associated logic.

In the event of a loss of the primary electrical power supply to the fire protection system, it shall be protected by an independent back-up/emergency system capable of maintaining the electrical supply for a period sufficient to achieve a tolerable level of risk.

The fire protection system shall, where specified, transmit a specific alarm signal to any associated Central Control Panel to provide comprehensive information for operational personnel.

Activation of a single fire detector shall initiate an alarm signal.

Activation of a second detector or second detector type shall initiate appropriate actions that may include but are not limited to the following:

- a) transfer a signal to the gas turbine control system for initiating gas turbine trip;
- b) close the applicable fuel safety shut-off valve(s) (see 5.10.5.5 and 5.10.6.5);
- c) actuate related warning devices;
- d) trip the ventilation system of the enclosure;
- e) close ventilation inlet and exhaust dampers;

NOTE In some cases, this may be achieved by the extinguishant action.

- f) actuate the automatic fire extinguishing system, after the time delay necessary for personnel protection, where applicable.

Activation of a single fire detector, where applicable, may be used to initiate the appropriate actions above.

The sound level of an acoustic alarm shall be audible above the noise level of the building/area in normal operation, except that red (or another nationally required colour) flashing lights shall be provided in areas with an average sound level greater than 105 dB(A) at 1 m in addition to the acoustic alarm.

Where a serious fault alarm signal is received from the fire protection system an alarm, which can only be manually reset, shall be initiated. Equipment start-up shall be interlocked or the operation manual shall indicate that start-up is not permitted before the failure is identified and solved. Equipment shall be monitored for open and short circuit conditions or other appropriate measures shall be implemented to achieve a tolerable level of risk.



NOTE 2 A serious fault alarm is an alarmed fault that, if not rectified, affects the ability of the system to operate correctly.

### 5.15.9 Escape

Suitable safeguards shall be provided to allow prompt evacuation, to restrict entry to dangerous areas and to provide means for prompt rescue of any trapped personnel.

There shall be adequate escape routes from the structures to the outdoors. Exit doors shall open in the direction of exit. Where appropriate escape routes shall be marked and provided with emergency escape-route lighting.

### 5.15.10 Uncontrolled release of media and loss of propellant pressure

A method of monitoring and/or weighing the fire extinguishant vessels' contents that does not require disconnection of the vessel shall be provided so that, if the vessel contents escape or leak, appropriate action can be taken. Where manual checks are used they shall be conducted at intervals that ensure that unacceptable leakage is detected.

Where a nitrogen gas supply is used to actuate the extinguishant release mechanism or as a propellant to eject water in a water mist system, the pressure in the nitrogen vessel(s) shall be monitored so that, if the vessel(s) contents escape or leak, an appropriate alarm shall be provided.

Where low temperature conditions can cause a drop in the pressure of propellant gas vessels suitable heating shall be provided to maintain the vessel(s) at a temperature such that an acceptable pressure is achieved.

Where the potential exists for external influences to activate fire detection equipment appropriate precautions shall be taken, e.g. covers at enclosure windows to prevent activation of detectors by local radiation, such as welding arcs.

### 5.15.11 Vessel thermal relief (burst disc)

Protection shall be provided against overheating when fire extinguishant or nitrogen propellant vessel(s) are located in areas subject to strong sunlight or other heating effects that can cause an uncontrolled pressure increase and operation of the vessel valve burst disc. Propellant or extinguishant vessels shall not be installed inside a gas turbine enclosure.

Methods of protection may include but are not limited to

- a) vessels mounted in a suitably ventilated cabinet,
- b) vessels located in natural shade,
- c) provision of canopies or similar protection against surface heating.

The vessel valve burst disc shall be orientated or otherwise guarded so that if the burst disc operates personnel in the immediate area cannot be harmed.

### 5.15.12 Vessel and/or pipe failure

Fire extinguishant and nitrogen propellant vessels shall be suitably mounted and protected from damage.

Where potentially damaging exposure or unauthorized interference is likely, suitable enclosures or guards shall be provided.

Piping shall be routed so that the potential for damage due to mechanical or other causes is minimized.

### 5.15.13 Release of extinguishant into gas turbine halls, control rooms, etc.

If vessels and the associated pipework for fire extinguishant systems are located in gas turbine halls, control rooms or similar areas where personnel access is required and there is the potential for asphyxiation due to the extinguishant used and the potential concentrations that could be achieved on release, the precautions in 5.15 and 5.13.9 shall be applied where relevant.

## 5.16 Hazardous area classification and explosion prevention and protection

### 5.16.1 General

Where the potential exists for flammable gases, vapours or mists to arise, the areas shall be classified and appropriate precautions shall be taken against explosions in accordance with ISO 14121-1:2007; IEC 60079-0:1998, IEC 60079-10, IEC 60079-14:2008, EN 1127-1:1997 and EN 13463-1:2001.

Where local legislation recognizes other established standards, such as NFPA 70:2005 and NFPA 497:1997, that achieve an equivalent level of safety and certification of equipment, these documents may be used as alternatives.

### 5.16.2 Area classification

Hazardous area classification shall be carried out for all plant items where flammable gas, vapour or mist risks can arise. Areas shall be classified into zones (as defined in IEC 60079-10) and the extent of the zone determined in accordance with IEC 60079-10. The extent of the zone adjacent to any ventilation inlet shall take account the increased airflow in the area and the potential for flammable gases, vapours or mists to be drawn into the inlets.

**NOTE** Flammable mist can be formed from pressurized fluid leakage at a temperature below the flash point of the fluid. IEC 60079-10 excludes areas where the presence of flammable mist can give rise to an unpredictable risk, which require special consideration, but advises that mists can form or be present at the same time as flammable vapours which can affect the way the flammable material disperses and the extent of any hazardous areas. The strict application of area classification for gases and vapours might not be appropriate because the flammability characteristics of mists are not always predictable. Whilst it can be difficult to decide upon the type and extent of zones, the criteria applicable to gases and vapours will, in most cases, give a safe result. However, special consideration should always be given to the danger of ignition of flammable mists in the presence of hot surfaces. See 5.13.7.

Where equipment is located in an enclosure and ventilation is used to control the hazardous areas, the area classification shall take into account the conditions when the ventilation is not present. De-energizing the electrical supplies or isolation and venting/de-pressurization of fuel and high pressure hydrocarbon systems or a higher level of equipment classification or other appropriate actions may be required based on risk assessment.

The category defining the extent of protective measures to be taken shall be as defined in EN 1127-1:2007, 6.4.1.

EN 1127-1:2007, Annex B, describes the relationships between categories and zones.

Hazardous area classification drawings shall be prepared in accordance with IEC 60079-10, 6.2.

### 5.16.3 Explosion prevention

The methods described in EN 1127-1:2007 shall be used for the identification and assessment of the hazardous situations and the concepts and methodology for explosion prevention therein shall be applied. Remaining risks shall be assessed in accordance with ISO 14121-1:2007, taking into account EN 1127-1:2007, Clause 5, and the methods described in EN 1127-1:2007, Clause 6, to eliminate or minimize risks.

Where there is the potential for any significant quantity of hot gas or air to leak from the equipment casings and cause damage to ancillaries, controls, certified equipment or safety devices, means shall be provided to prevent such an occurrence leading to a hazard.

## 5.16.4 Ignition source control

### 5.16.4.1 General

All equipment shall be designed and constructed so far as possible to prevent ignition sources that can occur during normal operation and reasonably foreseeable machinery fault conditions.

### 5.16.4.2 Electrical ignition sources

Electrical apparatus for explosive gas atmospheres, for the identified zone and category, shall comply with IEC 60079-0:2004 and IEC 60079-14:2002.

### 5.16.4.3 Non-electrical ignition sources

#### 5.16.4.3.1 General

Non-electrical equipment used in potentially explosive atmospheres shall comply with the requirements of EN 13463-1:2001 or shall be located in an area that meets the dilution ventilation requirements in 5.16.5.3.

#### 5.16.4.3.2 Hot surface temperatures

Where the surface temperature exceeds the AIT (see 5.16.4.4) of any flammable gas, vapour or mist leak that can impinge on the surface, additional measures shall be taken to prevent such leaks, not readily dispersible by any dilution ventilation airflow (see 5.17.5), from contact with the surface.

### 5.16.4.4 Auto-ignition temperature data

Values of AIT from IEC/TR 60079-20:1996, or otherwise from a verified source, shall be used. For mixtures, unless test data are available, the AIT of the component having the lowest AIT and present at a concentration of over 3 % (by volume) shall be used. If no relevant data are available, the AIT of relevant substances shall be measured in accordance with IEC 60079-4:1975 as amended by IEC 60079-4-AM:1995, or by another equivalent method.

An appropriate safety margin shall be applied to the value of the AIT for use where indicated as necessary by risk assessment.

**NOTE** The capability of a heated surface to cause ignition of a potentially explosive atmosphere depends on the type and concentration of the particular substance in the mixture with air. This capability becomes greater with increasing temperature and increasing surface area. The temperature that triggers ignition depends on the size and shape of the heated body, on the concentration gradient in the vicinity of the surface, the contact time of the explosive atmosphere with the heated body and, to a certain extent, also on the surface material and the potential for catalytic reactions. Thus, for example, an explosive atmosphere can be ignited by surface temperatures lower than the AIT measured in accordance with IEC 60079-4:1975 as amended by IEC 60079-4-AM:1995, or by other equivalent methods. On the other hand, in the case of heated bodies with convex rather than concave surfaces, a higher surface temperature is necessary for ignition; the minimum ignition temperature increases, for example, with spheres or pipes as the diameter decreases. Likewise when an explosive atmosphere flows past heated surfaces, a higher surface temperature is normally necessary for ignition owing to the brief contact time.

## 5.16.5 Reduction of explosion effects in an enclosed space

### 5.16.5.1 General

If the measures described in 5.16.1 and 5.16.2 (area classification), 5.16.3 (explosion prevention), 5.16.4 (ignition source control) and 5.13.4 (ventilation) do not provide a sufficient level of safety for enclosed spaces, the additional measures described in 5.16.5.2 (explosion relief) and/or 5.16.5.3 (pressure resistant design) and/or 5.16.5.4 (suppression) shall be implemented.

### 5.16.5.2 Explosion relief

Where necessary in accordance with 5.16.5.1 explosion relief in accordance with EN 1127-1:2007, 6.5.3, shall be implemented for an enclosed space. Relief panels shall be sized in accordance with NFPA 68.

The set point for the operation of relief panels shall be less than the internal overpressure that can cause any personnel access doors or maintenance panels to be forced open. Relief panels (if fitted) shall be retained by hinges or other mechanical means to prevent them from becoming loose missiles and so as to prevent injury to personnel during opening.

In the event of relief panel operation appropriate action shall be initiated. A gas turbine trip shall occur when the relief panel is associated with the gas turbine enclosure.

### 5.16.5.3 Explosion pressure resistant design

#### 5.16.5.3.1 General

Where necessary in accordance with 5.16.5.1, an explosion pressure resistant design in accordance with EN 1127-1:2007, 6.5.2.2, shall be implemented for enclosed spaces based on the use of dilution ventilation and its validation in accordance with 5.16.5.3.2 and 5.16.5.3.3 to limit the overpressure from an explosion event such that the pressure is reduced to a level that is unlikely to cause personnel injury and is contained within the enclosed space.

#### 5.16.5.3.2 Dilution ventilation

Dilution ventilation shall be applied to ensure that areas of stagnant or inadequate ventilation are minimized so that, in the event of a leak, the potentially explosive cloud is diluted by jet mixing with the surrounding air and the mixture is immediately and effectively removed by the ventilation. Explosive concentrations are therefore restricted to the mixing zone and its immediate vicinity, and shall be sufficiently small, as given in 5.16.5.3.3, relative to the size of the enclosure space that, in the event of ignition, the maximum overpressure from an explosion event is limited such that the pressure rise consequences are insignificant and safely contained. Thus the effective distribution of ventilation is more important than its quantity, since high ventilation rates can preclude the detection of small leaks by detectors in the outlet ducts and can result in larger explosive clouds with significant consequences in the event of ignition. Dilution ventilation shall always be associated with the use of gas detectors since it is designed to dilute reasonably foreseeable leaks within a defined range.

Where necessary to achieve effective dilution ventilation, a combination of additional inlet positions, distribution ducts and distribution baffles may be used to direct the ventilation air flow to points of stagnation and re-circulation. Account shall be taken of the flow patterns at cold start-up and running when different thermal conditions exist.

#### 5.16.5.3.3 Ventilation validation

Computational fluid dynamics (CFD) modelling or other quantifiable techniques shall be used to validate dilution ventilation in accordance with 5.16.5.3.2 to ensure adequate dilution of a leak is achieved. The modelling shall show that the leak cloud volume at the 100 % LEL contour arising from the leak that can cause a gas turbine trip based on gas detection trip settings in the ventilation outlet ducts, converted to an equivalent volume at stoichiometric concentration, shall be no larger than 0,1 % of the net volume of the enclosure. Since there is no specific numerical safety factor included within the criterion, a safety factor should be applied based on risk assessment taking the circumstances of the plant and any mitigation into account. In all cases, the gas leak rate for the purposes of CFD should be based on a hole size no smaller than 0,25 mm<sup>2</sup> and no larger than 25 mm<sup>2</sup> and the equivalent volume at stoichiometric concentration should not exceed 1 m<sup>3</sup>. This criterion has been validated to show that, in the event of ignition, the overpressure created will not exceed 1 000 Pa (10 mbar). If the enclosure strength can be assessed to withstand an overpressure of up to 1 500 Pa (15 mbar), the criterion may be extrapolated to an envelope not exceeding 0,15 % of net volume and an overpressure of 1 500 Pa (15 mbar).

Prior to the completion of commissioning of each initial design, ventilation validation *in-situ* measurements shall be undertaken to ensure that areas of stagnant or inadequate ventilation are minimized.

Where analysis shows that unacceptable gas clouds or concentrations that cannot be removed by other means can occur, additional appropriately located gas detectors shall be installed.

Measurements shall verify that the CFD model provides an acceptable representation of the air velocities and heat balance. Where necessary the CFD geometry and parameters shall be adjusted to obtain an acceptable match between the measurements taken and the CFD model output.

NOTE Additional guidance is given in HSL ECO/03/06, HSL CM/04/09, and HSL CM/03/12.

#### 5.16.5.4 Explosion suppression

Explosion suppression systems prevent an explosion from attaining its maximum explosion pressure by rapidly injecting extinguishing agents into the equipment in the event of an explosion. Where necessary in accordance with 5.16.5.1, explosion suppression in accordance with EN 1127-1:2007, 6.5.4, shall be implemented for an enclosed space. In the event of activation, appropriate action including a gas turbine trip shall be initiated.

### 5.17 Ventilation

#### 5.17.1 General

Ventilation of enclosed spaces shall be provided to

- a) provide temperature control to ensure the intended operation of equipment is achieved,
- b) control hazardous zones and promote the dilution of flammable gas, vapour and mist leaks.

#### 5.17.2 Cooling

Where the functionality of safety relevant equipment is dependant upon its use within its designed temperature range and alternative systems that are capable of keeping the equipment temperatures within the range, under all reasonably foreseeable operating conditions, are not installed, ventilation shall be used to provide an appropriate level of cooling or heating. See 5.17.3.

The effectiveness of the chosen solution to provide temperature control of equipment within its designed temperature range, under any reasonably foreseeable operating or fault condition, shall be validated.

#### 5.17.3 Heating

Where ventilation air is heated to prevent icing conditions or heated where the functionality of safety relevant equipment is designed only for a specific temperature range and alternative systems that are capable of keeping the equipment temperatures above its minimum operating limit are not installed, the heating shall be by

- a) an electrical heater, appropriately certified as necessary, e.g. for use in a hazardous area, or
- b) an indirect heat source, the design of which ensures that flammable gases and vapour or any other substance that can create a hazardous situation do not enter the air stream.

Gas turbine compressor delivery air may be used directly to provide heating when stable running conditions are achieved. The take-off point, controls and piping design shall prevent the occurrence of excess flow and the accumulation of unburnt hydrocarbons and shall reduce the potential for burnt/unburnt products of combustion to enter the inlet and cause a hazardous situation on flameout or gas turbine compressor surge.

#### 5.17.4 Hazardous area control

Where a hazardous area exists in an enclosed space, a partially enclosed space or an enclosure, ventilation shall be used to dilute potential leaks of flammable gases and vapours by dispersion into the air until their concentration is below the lower explosive limit. The degree (high, medium, low) and availability (good, fair, poor) of ventilation shall be assessed in accordance with IEC 60079-10 for the purpose of area classification. See also 5.16.2.

Areas of stagnant or poor ventilation, where recirculation and re-entrainment can arise, shall be minimized by ensuring that the ventilation is effectively distributed.

Where heavier-than-air flammable gases or vapours can be present in enclosures, artificial ventilation shall be used to ensure that any gas or vapour concentrations are effectively dispersed from low levels. Where there is the potential for vapours to migrate and accumulate in adjacent low level areas and trenches, precautions shall be taken (e.g. filling or sealing of trenches, additional gas detectors). The permit to work system shall include testing of the atmosphere prior to accessing any trench or low-level area.

#### 5.17.5 Hot surfaces

Where hot surfaces exist or can exist under any reasonably foreseeable normal operating conditions in the hazardous zone that are above the AIT (see 5.16.4.4) of a flammable gas, vapour or mist that can be present due to a leak, or where risk assessment indicates a residual risk of ignition, additional measures in accordance with 5.16.5 shall be implemented. The potential for hazardous leaks in enclosures containing hot surfaces shall be limited to secondary grades of release as defined in IEC 60079-10.

Where practical, the ventilation airflow direction shall be arranged so that any flammable leaks are directed away from hot surfaces.

#### 5.17.6 Ventilation inlet location

The ventilation air should preferably be drawn from a non-hazardous area taking into account the suction effects on the surrounding area. Location in a zone 2 area shall be considered acceptable only where a risk assessment indicates that the largest credible leak is capable of being diluted to such an extent by the ventilation air stream that a hazardous situation cannot arise. Risk assessment shall also take account of the risks of reverse flow when the ventilation system is not operating.

Where a zone 2 area exists, as described above, or the potential still exists for a potentially explosive atmosphere to enter the ventilation air inlet as described in 5.9.5 for the gas turbine compressor air inlet, the actions described therein shall be taken for the ventilation inlet.

#### 5.17.7 Ventilation inlet filtration

Where the potential exists for dusts or other forms of contaminant to enter the ventilation air inlet that can build up to form combustible deposits, especially on hot surfaces, or prevent the correct operation of safety equipment, suitable filtration shall be installed to prevent this build-up.

Where, due to the type of filtration used or environmental conditions, the potential exists for icing, suitable precautions shall be taken.

Where atmospheric pollution or environmental conditions exist (e.g. build-up of salt spray) that can affect the operation of safety devices within enclosures, appropriate filtration shall be supplied.

#### 5.17.8 Ventilation inlet ducting

The ventilation inlet ducting shall normally be routed to avoid hazardous areas. Where this is not possible, the ducting integrity shall prevent unacceptable leaks.

### 5.17.9 Ventilation outlet location

The ventilation air outlet shall not be located in a zone 0 or 1 area. Location in a zone 2 area shall be considered acceptable only where risk assessment indicates that the largest credible outdoor leak is capable of being diluted to such an extent by natural ventilation that the risk from reverse flow when the ventilation system is not operating is mitigated.

Account shall be taken of any hazardous area created by the ventilation outlet.

### 5.17.10 Flow monitoring — Artificial ventilation

Ventilation flow shall be monitored and interlocked to the start sequences of equipment so that the start-up is inhibited without sufficient ventilation and enclosure purging.

Means shall be provided to prevent a start-up with defective ventilation monitoring equipment.

During operation, if inadequate ventilation is detected, a shut-down shall be initiated within a safe period of time unless the supply is automatically restored from alternative fans or any alternative power supply. The shut-down period shall be as short as practicable and determined after a risk assessment has been performed.

Where the concept of 5.16.5.3 has been applied, flow monitoring shall detect inadequate and excessive flow rates if excessive flow rates are possible due to design or installed equipment.

If a gas leak that leads to a dangerous concentration is detected during the period before adequate levels of ventilation are reinstated, the gas turbine shall be shut-down and the pressurized parts of the gas system within the enclosure vented.

Where a method is implemented to inhibit the ventilation flow monitoring to allow the opening of enclosure doors (e.g. for inspection) a suitable warning shall be repeated at the gas turbine control panel until the monitoring has been restored.

## 5.18 Fans

### 5.18.1 Fan guards and structural failure

Guarding for fans shall be provided to eliminate the risk of entrapment or contact with moving parts. Guards shall comply with ISO 12499:1999 and retain the fan blades in the event of failure. The design of the fan housing shall contain any failure of fan components.

NOTE Guidance is given in prEN 14461:2002.

### 5.18.2 Air blast oil coolers

The impact hazard of the fan blades being released and causing damage to the cooler with the potential for process fluid leakage and possible fire shall be part of risk assessment. The design of the fan plenum shall contain any failure of fan components.

The location of the air blast cooler assembly shall be such that if leakage of the matrix occurs due to fan debris or other foreign matter, the potential for ignition is minimized.

## 5.19 Flammable gas detection

### 5.19.1 General

Detectors shall comply with IEC 60079-29-1:2007.

### 5.19.2 Type/selection principles

Gas detector measuring principles and selection shall be based on the relevant requirements of IEC 60079-29-2:2007, taking into account the potential for malfunction of the detector(s) due to pollutants/substances in the air stream.

### 5.19.3 Location principles

The location of fixed gas detectors shall be based on the criteria in IEC 60079-29-2:2007, Clause 8. Enclosed ventilated spaces containing gas fuel or liquid fuel with a flash point less than 55 °C shall be equipped with at least one gas detector located in the ventilation outlet. The location of the detector(s) in the outlet should take account of the mixture concentration contours within the air stream to ensure detection is achieved.

NOTE The *Institute of Petroleum Model Code of Safe Practice*, Part 15, Annex A, provides further guidance on vapours produced by liquid fuels at flash point temperatures.

When heavier-than-air gases are used as the main or alternative fuel, extra gas detectors shall be fitted at a low level in the enclosed space to detect any gas or fuel vapours that can have accumulated.

### 5.19.4 Settings

The lowest practical level shall be used for the gas detector settings for both alarm and trip, taking into account the need to avoid spurious signals. Adjustments shall be carried out in accordance with the manufacturer's manual. Settings shall be chosen in conjunction with the ability of the ventilation system to dilute potentially flammable gas and vapour leaks and shall be the subject of risk assessment.

The gas detector(s) in ventilation outlets shall be set to alarm at not more than 10 % LEL and trip at not more than 25 % LEL. Where gas is detected at the trip setting, the control system shall give an appropriate audible and visual warning and initiate a gas turbine shut-down, and potential sources of leaks shall be isolated and vented. Gas detectors may also be installed at other locations; their alarm and trip settings shall be subject to risk assessment.

### 5.19.5 Enclosures containing hot surfaces — Screening tool

Where hot surfaces exist in an enclosure, as described in 5.17.5, a one dimensional jet model may be used as a preliminary screening tool to determine if the % LEL setting of a gas detector at an enclosure vent outlet, in conjunction with dilution ventilation, is likely to control the size of the explosive cloud arising from a detectable leak, the size of the leak cloud being compared with the enclosure size, such that in the event of ignition, the consequences of the pressure rise are insignificant and safely contained.

The screening calculation should be undertaken by comparing the volume of the cloud at the envelope defined by the 100 % LEL contour, and converted to an equivalent volume at stoichiometric concentration, with 0,1 % of the enclosure volume. Where the defined cloud volume is less than this proportion of the enclosure volume, well distributed dilution ventilation is likely to ensure that the gas detector setting and design ventilation rate may allow the cloud volume to be controlled. However, such a method cannot take account of turbulence, ventilation direction, recirculation or the effect of obstacles, and should be used with caution. Jet leak impingement on a flat surface adjacent to the leak source might not be adequately diluted by normal ventilation velocities, whilst ventilation direction can reduce the cloud size by a large factor.

The effects of the dilution ventilation air flow on the size of the jet leak cloud shall always be validated in accordance with 5.16.5.3.3.

### 5.19.6 Maintenance and calibration

Maintenance and calibration procedures shall comply with 7.7.6 of this International Standard. The recommended test gas used for calibration shall comply with the general requirements of IEC 60079-29-1:2007, 5.3.

The LEL levels shown in IEC/TR 60079-20:1996 shall be used as datum values except where the major constituent is less than 90 % by volume, in which case specialist advice shall be obtained from the detector manufacturer with respect to an appropriate LEL value.



## 5.20 Control and automatic protection systems

### 5.20.1 General

Safety related control functions and the associated sensors, control logic and actuated devices (e.g. those for fuel isolation, fire detection, fire suppression, combustion supervision, gas detection, ventilation detection, overspeed detection and emergency stop) shall be identified and designed, tested, installed, commissioned and validated. It is recommended to apply relevant standards such as IEC 61508-1:2001 and/or IEC 61511-1:2003 and the appropriate normative references therein.

### 5.20.2 Environmental suitability

Protective systems shall be designed, selected and constructed such that they are capable of performing their intended function under all reasonably foreseeable environmental/operating conditions (e.g. voltages, humidity, vibration, contamination, UV exposure, pollution, climatic and other external effects), taking into account the operating-condition limits specified by component/equipment manufacturers.

Equipment parts used shall be appropriate to the intended mechanical and thermal stresses and capable of withstanding attack by existing or reasonably foreseeable aggressive substances.

Special consideration shall be given to the temperature capabilities of control devices, taking into account the effects of thermal radiation, which may involve the completion of temperature surveys.

Where a heating or air conditioning system is required to control the environment for the gas turbine control module to ensure that the required level of functional safety is achieved, if power is lost to this system, automatic actions shall be taken to safeguard the gas turbine control module.

### 5.20.3 Ergonomics

Ergonomic principles shall comply with ISO 12100-2:2003, 4.8.

### 5.20.4 Failure

The probability of failure of safety functions shall be minimized in accordance with the requirements of ISO 12100-2:2003, 4.12.

When the control signal is removed from a valve or control device that is essential for shut-down or continued operation with tolerable risk, the valve or device shall automatically move to its fail-safe position.

Where indicated by risk assessment, component redundancy or the fail-safe principle for electrical circuits shall be used to perform a safety function and provide the necessary SIL. See 5.2.

### 5.20.5 Calibration

Control systems shall be designed to allow calibration of safety related functions where applicable. If calibration is required to be performed while the engine is running it should not lead to an interruption of operation or compromise the safety of the machine. See also 7.7.7.

### 5.20.6 Testing

As far as practicable control systems shall be designed to allow testing of safety functions with the engine stopped, and fuel isolated.

Where necessary to achieve the required level of integrity, the control system shall allow the in-service testing of functions during gas turbine operation without allowing unprotected operation.

The safety functions shall be listed in the operation manual and the procedures for such testing shall be suitably described unless fully automated by the control system. See 7.7.7.

Safety related control systems shall be self-monitoring and self-diagnostic, where necessary, to achieve an acceptable level of reliability. Errors discovered shall be annunciated to the operator. Where operator action is required, it shall be clearly indicated on the control panel, and the action required should be similarly indicated or described in the operation manual.

Functional tests shall be made during commissioning, after any intrusive maintenance or automatically before starting. The manufacturer shall recommend the frequency and extent. See 7.7.7.

### **5.20.7 Speed control**

To provide protection against failure of the speed measurement or of the speed controller, an independent or fail-safe overspeed protection system shall be provided to limit the overspeed of each shaft by immediately tripping the fuel supply to the gas turbine. The measurement range of the speed sensors shall be selected such that the measurement at the trip limit is still reliable and accurate.

Overspeed settings shall be determined following risk assessment by the gas turbine and driven-unit suppliers. The setting shall exceed the speed resulting from sudden loss of maximum potential power with a margin that avoids spurious trips but does not result in overstressing of the rotating parts.

The overspeed protection system shall have in-built testing functionality, or provisions shall be made for the testing of all overspeed protection devices at intervals recommended by the gas turbine manufacturer.

Gas turbines with separate power turbines or with heat exchangers can require additional protection against overspeed because of the stored heat, or large stored volumes of high pressure, or both. Adequate protection measures shall be the subject of risk assessment.

For multiple rotor shaft engines, if it can be shown that it is not possible for a rotor to overspeed due to aerodynamic forces, an overspeed protection system is not required on that rotor.

### **5.20.8 Gas turbine emergency shut-down system**

An emergency shut-down system shall be provided. It shall be separate from the main control system and capable of manual operation. It shall also be operated automatically by safety related gas turbine protection devices and any safety related process plant protection devices that affect the safe operation of the gas turbine.

The control system shall be designed so that the emergency shut-down system including the emergency stop buttons, trip not only the gas turbine by acting on the fuel shut-off valves to immediately cut off the fuel supply but also all associated equipment upstream and/or downstream if its continued operation can produce a hazard.

The gas turbine package or enclosure, as applicable, and the control panel shall be equipped with emergency stop buttons, appropriately located, clearly marked and directly accessible, which shall be active during normal and maintenance operations.

These buttons shall

- a) have clearly identifiable, clearly visible and quickly accessible controls and require manual reset after operation;
- b) stop the gas turbine and any associated equipment at risk as quickly as possible, without creating additional hazards;
- c) not be part of a human-machine interface (HMI) (e.g. touch screen) display.

The action of the emergency stop shall set the driven equipment to a safety state commensurate with shut-down of the gas turbine and should override any other functions of the driven equipment.

If other standards require local stop buttons for each drive or subsystem, this can create additional risks for the complete gas turbine system, which shall be taken into account.

An audible warning shall be set off by any emergency stop. If an HMI is used, a message shall be displayed to indicate that the emergency stop has occurred.

Risk assessment shall determine the functions to be maintained in each case of emergency stop to minimize the consequences (e.g. in case of gas leakage detection, the ventilation system is maintained in action to purge the enclosure, but in the event of fire the ventilation should be shut-down and the fire dampers should close to enable the fire to be extinguished).

An automatic re-start shall not be possible after an emergency stop without a manual intervention. Prior to a re-start a check by operating personnel shall be undertaken to ensure that the fault that initiated the shut-down has been resolved such that operation with a tolerable risk can proceed.

### 5.20.9 Interlocks

The control system shall provide interlocks that prevent engine start or ignition if this can result in unsafe conditions based on the current status of the systems. Interlocks shall be reset only after correction of the cause. The control system shall indicate which system has initiated the operation of an interlock.

## 5.21 Electrical

### 5.21.1 Design/Installation

Electrical equipment of drives, control systems, measuring and control devices, lighting and heating shall, where relevant, comply with IEC 60204-1:2005, IEC 60204-11:2000 and IEC 60079-14:2002.

### 5.21.2 Isolation and stored energy

#### 5.21.2.1 General

For maintenance and inspection purposes and in an emergency, means for energy isolation for electrical supplies  $\leq 1$  kV shall comply with IEC 60204-1:2005, 5.3. Isolating devices for supplies  $> 1$  kV shall provide all-pole load disconnection and contact clearances shall be appropriate to ensure isolation.

Devices for the prevention of unexpected start-up shall comply with ISO 14118:2000. Where necessary, local stop buttons shall be provided in accordance with IEC 60204-1:2005, 5.4. Where a hazardous situation cannot be created and where necessary, local stop buttons shall be provided in accordance with IEC 60204-1:2005.

Where electrical isolation by a plug/socket combination under the immediate supervision of the person present in the danger zone is not possible, the isolation devices shall be capable of being locked or otherwise secured in the "isolated" position.

#### 5.21.2.2 Isolation of electrical equipment in potentially hazardous areas

Isolation of other than intrinsically safe circuits shall comply with IEC 60079-17:2007, 4.8.1. Isolation of intrinsically safe circuits shall comply with IEC 60079-17:2007, 4.8.2.

#### 5.21.2.3 Stored energy

Dissipation of stored energy for maintenance and inspection for supplies  $\leq 1$  kV shall comply with IEC 60204-1:2005, 6.2.4. Supplies greater than 1 kV shall have suitable earthing, bleed resistors or short circuit arrangements. Large capacitors for variable speed drives or other similar equipment shall have warning labels detailing instructions/times for safe discharge.

### 5.21.3 Electrostatic energy and bonding

#### 5.21.3.1 Non-conducting parts

Non-conductive mechanical equipment parts exposed to the explosive atmosphere and susceptible to electrostatic charging shall comply with EN 13463-1:2001, 7.4.

#### 5.21.3.2 Conducting parts

Equipment shall be arranged so that dangerous electrical potential differences cannot exist. Bonding shall comply with the requirements in IEC 60204-1:2005.

If there is a possibility of isolated metal parts becoming charged and acting as an ignition source or a risk to persons, then bonded terminals shall be provided and used to continuously dissipate the charge.

Where conductive parts are used for the conveyance of non-conductive fluids and gases and the continuity of conductivity is broken by the use of non-conducting flexible connection or by other means, terminals shall be provided at each side of the break and the parts bonded together, unless there is a valid need for the insulating section, such as to prevent circulating currents in generator bearings.

Shielded cables shall be used where necessary to prevent interference and signal degradation. Continuity of shields shall be ensured. At least one end of each shield shall be earthed.

NOTE For hazards associated with lube oil conductivity, see 5.24.1.

#### 5.21.3.3 Stray electric currents

Activities (e.g. local arc welding) within the proximity of the equipment that can induce stray electrical currents leading to the potential for electrical discharge shall be restricted during operation. Where it is necessary to carry out essential arc welding work close to any zoned area, appropriate safeguards shall be taken (e.g. local earthing to ground).

### 5.21.4 Water ingress

Electrical enclosures shall be rated in accordance with IEC 60529:2001 and be suitable for the environmental conditions in which they are operated. Ingress protection IP 54 is recommended as a minimum for outdoor conditions. In cases where water jets or compressed air are used for cleaning, a suitable higher category should be used. The means of introduction of a cable with its glands, bushings, etc., into an enclosure shall ensure that the degree of protection of the enclosure is not reduced. Cable connectors/glands, flexible conduits and fittings shall offer at least the same level of protection as defined for associated enclosures in accordance with IEC 60204-1:2005 and IEC 60204-11: 2000.

### 5.21.5 Lightning

If risks due to lightning have been identified, risks shall be minimized in accordance with EN 1127-1:2007, 6.4.8. Over voltage protection shall comply with IEC 60204-1:2005, 7.9, and IEC 60204-11:2000, 7.4, if danger to electrical equipment caused by over voltage can be foreseen.

NOTE Further information on the design, installation, inspection and maintenance of lightning protection systems (LPS) can be found in IEC 62305-1:2006. The effects of lightning can be particularly hazardous to computer systems, regulation or control systems and power supplies and can lead to explosions, fire or injury to persons.

### 5.21.6 Electromagnetic compatibility (EMC)

The equipment shall not generate electromagnetic disturbances above levels that are appropriate for its intended place of use. In addition, the equipment shall have an adequate level of immunity to electromagnetic disturbances so that it can operate correctly in its intended environment.

Electromagnetic emissions and immunity shall comply with IEC 61000-6-4:2006 and IEC 61000-6-2:2005 respectively.

Cables shall be installed with sufficient separation to avoid electromagnetic interference. This is normally provided by routing signal cables separately from power cables, and terminating them in separate junction boxes, where applicable.

Installations and earthing and cabling shall comply with the general guidelines in IEC/TR 61000-5-1:1996 and IEC/TR 61000-5-2:1997 respectively.

General disturbances can be limited by applying the measures in IEC 60204-1:2005, 4.4.2.

### **5.21.7 Battery installations**

Battery installations shall comply with EN 50272-2:2001.

### **5.21.8 Electrical overload**

Dangerous overloading of electrical equipment shall be prevented at the design stage by means of integrated measurement, regulation and control devices, such as over-current cut-off switches, temperature limiters, time-lag relays, overspeed monitors and/or similar monitoring devices.

Where, under reasonably foreseeable circumstances, there is the potential for circuit overloads in the equipment greater than the design limits, appropriate protection devices shall be installed in accordance with IEC 60204-1:2005, Clause 7.

### **5.21.9 Electrical power failure**

#### **5.21.9.1 System failures**

Risk assessment shall be carried out to determine the consequences of power failure to the control system and safety devices and to identify the need for the provision of alternative power supplies such as independent feeds, standby generators or batteries.

If no alternative supply is provided, or if the alternative fails to become available, shut-down shall be achieved with a tolerable level of risk.

If a limited alternative supply is provided, the systems that it is to feed shall be identified so as to minimize the risks and avoid hazardous situations.

In the case of battery back-up systems, a shut-down shall be initiated before the remaining battery power becomes insufficient for a safe shut-down of the equipment.

#### **5.21.9.2 Electrical power restoration**

Following power failure, those systems that are automatically restored to operation shall be identified, and shall be designed so as to avoid hazardous situations.

## **5.22 Drains, vents and bleeds**

### **5.22.1 General**

The hazards associated with drains and vents shall be determined and shall be specified for each interface point, together with the details of the type(s) of media, the mode of operation and the flow rate and temperature. The details of any hazards shall include, but are not limited to, heavy metals, recycling, corrosion, fire and explosion risks, contact and/or inhalation of harmful fluids, gases, mists, fumes and dust.

The base plate or foundation shall be designed to ease the collection of liquid and to retain the quantity of leaked liquids collected before the detection of the leak. The location of the drain point of the baseplate shall minimize the quantity of liquid retained after the drain operation.

All manual drain valves shall be easily accessible.

Gas turbine package drains and vents shall terminate in safe locations.

The noise generated from vents shall be considered (see 5.7).

### **5.22.2 Vents for flammable gases**

Breathers from regulators or relief valves and vents from vent valves shall be terminated to atmosphere in an area without an ignition source. Protection against lightning shall be in accordance with 5.21.5. Special attention shall be given to ensuring that during running or shut-down gas cannot re-circulate into the gas turbine compressor air inlet, the gas turbine enclosure ventilation air inlet or outlet and at exhaust locations.

The hazardous area at the outlet point shall be suitably zoned in accordance with IEC 60079-10.

The design of the outlet shall be such that debris and any other potential foreign matter are prevented from entering the vent and arranged to achieve good dispersion taking into account the properties of the gas and anticipating any possible problems when venting from high pressures. The location of vent outlets shall not lead to hazardous areas impinging on other properties, i.e. those belonging to the public or a third party.

Vents shall be independently installed unless it can be shown that there is no potential for unsafe interaction between connected vents.

Where practical, the requirement for venting should be minimized.

Manual valves are not recommended on vent lines. Welded pipes are recommended to avoid additional hazardous area classification around mechanical joints on vent lines.

### **5.22.3 Toxic and hazardous emissions**

Means shall be provided to prevent the emission of hazardous substances from the machine in accordance with ISO 14123-1:1998. Where the measures described in ISO 14123-1:1998 cannot reduce the risk of toxic and hazardous emissions from vents or drains, additional precautions shall be taken to ensure that such emissions cannot reach a toxic or hazardous level that can cause unacceptable exposure levels.

Such measures may include, but are not limited to:

- a) increasing the height of vent outlets to provide dispersion to a tolerable level of risk;
- b) locating vent outlets in suitable areas where personnel access is normally prohibited;
- c) continually monitoring for toxic emissions at outlets in conjunction with the associated shut-downs and evacuation acoustic alarm and associated procedures;
- d) the use of coalescers for the removal of mist from vents.

### **5.22.4 Gas turbine compressor bleeds**

If local discharge of the bleeds can create a potentially hazardous situation they shall be piped/ducted to discharge to a safe location.

## 5.23 Pressure equipment

### 5.23.1 General

Pressure equipment (e.g. piping, vessels, associated assemblies and incorporated safety and pressure accessories) shall be designed and manufactured to comply with the applicable requirements in this International Standard and shall be tested and inspected to remain leak tight and withstand the pressure and vibration that can be reasonably expected during its foreseeable lifetime

NOTE Where temperature, temperature differences, thermal loads, containment, structural strength, stiffness or dynamic loads are the overriding design issues, gas turbine equipment under pressure, such as casings, are excluded from the scope of the European Directive 97/23/EC, the Pressure Equipment Directive.

### 5.23.2 Design

The pressure equipment shall be designed taking into account all relevant factors to ensure that the equipment is safe throughout its intended life and shall incorporate appropriate safety factors to ensure that an adequate safety margin exists to guard against all relevant failure modes in a consistent manner.

Account shall be taken of the full range of reasonably foreseeable loadings, internal and/or external pressure, ambient and operating temperatures, mass of piping/vessel and contents, climate loads, dynamic effects of the fluid, potential movements of structures, vibrations, earthquakes, transportation, handling, fatigue, reaction forces and applicable combinations of these loadings occurring simultaneously. The material, wall thickness, tensile strength, ductility, forming, joining and test methods shall be suitable for the specific media and withstand the reasonably foreseeable loadings that can occur. Where necessary, adequate allowance or protection against wear, erosion, corrosion, chemical attack and decomposition of unstable fluids should be provided, taking due account of the intended and reasonably foreseeable use.

Adequate provisions shall be provided for inspection and testing, where appropriate.

### 5.23.3 Hazards

The pressure equipment selected shall

- a) eliminate or reduce hazards as far as is reasonably practical, or
- b) apply appropriate protective measures to mitigate hazards that cannot be eliminated.

### 5.23.4 Misuse

Consideration should be given to the potential misuse of the pressure equipment (e.g. use as a means of access, climbing on it, standing on it or for storage).

### 5.23.5 Safe handling and operation

Reasonably foreseeable risks associated with handling and operation shall be analysed and provision for appropriate precautions shall be made (e.g. fitting padlocks at manual valves that, if incorrectly operated, can cause a hazard, fitting blanking plugs or flanges at manual valves opened to vent or drain and monitoring the pressure and/or the temperature in the equipment prior to disassembly).

Devices containing loaded springs that can cause injury if accidentally released shall be designed such that the spring load can be reduced to below 110 N before the spring is disassembled. Otherwise they shall be suitably guarded.

### 5.23.6 Isolation, draining and venting

Where applicable adequate means shall be provided for draining and venting of the pressure equipment to permit cleaning, inspection and maintenance with tolerable risk.

To avoid potential harmful effects (e.g. water hammer and vacuum collapse) all stages of operation and testing should be considered.

Where required for safe maintenance and inspection purposes, devices shall be provided for isolation and the dissipation of fluid pressure.

### 5.23.7 Fluid injection

The hazard of fluid injection into the human body shall be minimized by

- a) ensuring that all high pressure piping in a position where it is likely to be damaged is protected, robust and sufficiently supported,
- b) providing shielding (e.g. screens) to flexible piping installed adjacent to an operator's assigned working position to reduce the risk resulting from a failure in the flexible piping system where failure could cause harm to persons.

### 5.23.8 Assemblies

#### 5.23.8.1 General

Assemblies shall be so designed that the components to be assembled together are suitable and reliable for their duty and are properly integrated and assembled in an appropriate manner.

Assemblies shall be designed to prevent velocity and pressure fluctuations causing harmful oscillations in the system (e.g. by pressure regulation, correct pipe sizing, firm supporting and/or flexible couplings).

Piping, valves, pumps, etc. shall be arranged to minimize the number of vent connections required to prevent the formation of air or gas pockets in liquids that can cause unsafe operating conditions.

All piping, pipe fittings, passages, surge or storage tanks and cored or drilled holes shall be free from burrs or foreign matter that can cause damage to a system or lead to a dangerous situation.

Control valves and other control components requiring inspection or maintenance shall be mounted in positions that provide accessibility and avoid damage.

Where proprietary tube fittings are used, component parts from different manufacturers shall not be intermixed within a single fitting. Counter rotating (left hand and right hand) threads shall not be used on the same assembly where there is the potential for uncontrolled pressure release.

It is recommended that tube fittings from a single manufacturer be used throughout the plant.

#### 5.23.8.2 Pressure control and overpressure protection

Where there is the potential for exceeding the allowable pressure limits the equipment shall be protected by instrumentation, control or relief valves.

Adjustment of over-pressure protection devices shall be possible only with the use of an appropriate tool.

Safety devices shall be monitored as necessary and safe shut-down shall occur where abnormal deviations are detected.



### 5.23.8.3 Particulate contamination

The ingress of particles that can be detrimental to the safety of the equipment shall be prevented (e.g. by the incorporation of a suitable filter or strainer).

Filters and strainers should be positioned in such a way that periodic servicing remains easy.

Transparent bowls for filters or strainers (e.g. glass, plastic) shall be protected to prevent injury from flying particles if failure occurs.

### 5.23.8.4 Filling and drainage

A safe means of filling or draining systems or parts of systems during commissioning, maintenance and de-commissioning shall be provided.

### 5.23.8.5 Accumulators

The release of stored energy shall not lead to dangerous situations. Preferably, accumulators should be automatically and completely discharged when the respective system is shut-down. Where this is not possible or practical, a tolerable level of risk shall be achieved by other means.

### 5.23.8.6 Quick release connections

Where quick release connectors are used they shall be of the self-sealing type to prevent leakage and ingress of foreign particles and shall be of the type that prevents opening whilst under pressure. Consideration shall be given to the risk of incorrect reconnection if flexible lines are used; quick connects should not be the same on different services.

### 5.23.8.7 Pumps

The system downstream of a positive displacement pump shall be equipped with a relief device if the system can be blocked or closed. The relief fluid shall be piped to a suitable location where the backpressure does not allow the system design pressure to be exceeded under reasonably foreseeable conditions.

Where centrifugal pumps are used as a pressure source, relief devices need not be supplied provided the design of the associated piping and flanges is based on the maximum supply pressure and providing that excessive overheating cannot occur.

If there is the potential for leakage at a pump drive shaft seal that can cause contamination of other media and lead to a hazardous situation, the pump shall be fitted with double seals with the space between the seals suitably drained or vented or be fitted with other suitable measures.

Where relief or spill valve flow is returned to the pump suction the design shall be such that the credible flow shall not be capable of causing overheating with the potential for cavitation and vapour lock.

The relief device shall be adjusted in accordance with the supplier's instructions to prevent bursting of the pump casing or downstream piping if a malfunction occurs that prevents pump flow.

## 5.23.9 Safety accessories

### 5.23.9.1 General

Safety accessories are devices designed to protect pressure equipment against exceeding the allowable limits. Safety accessories shall

- a) be designed and constructed so as to be reliable and suitable for their intended duty and take into account the maintenance and testing requirements of the devices, where applicable;
- b) be independent of other functions, unless their safety function cannot be affected by such other functions;
- c) comply with appropriate design principles to obtain suitable and reliable protection and shall be designed so that, in the case of failure, a tolerable risk level is maintained until shut-down is achieved.

### 5.23.9.2 Pressure limiting devices

Pressurized systems, if the risk of over-pressure exists, shall be fitted with pressure limiting devices designed to provide pressure release or to otherwise limit pressure if the system's design maximum working pressure is exceeded. A momentary pressure surge is allowed if this does not result in a dangerous condition.

### 5.23.9.3 Thermal safety

Where hazardous excess pressure can occur in the pipework system due to thermal expansion of the liquid, means of pressure relief shall be provided.

Where thermal pressure relief valves are used on pressure equipment the outlet from the thermal relief valve shall be piped to a suitable drain where the backpressure does not allow the system design pressure to be exceeded under reasonably foreseeable conditions.

Where a high or low temperature of the liquid can occur and cause a hazard, the temperature shall be monitored and, if the design limits are exceeded, the gas turbine shall be shut-down with a tolerable level of risk.

### 5.23.10 Flexible piping (and metal hoses)

Flexible piping shall

- a) be as short as practicable consistent with proper bend radii and routing and without being distorted to a deformed shape or stretched in a manner that causes inappropriate permanent tension;
- b) be mounted in such a way as to avoid distortion, uncontrolled movement and damage during pressurization;
- c) withstand the maximum vibration levels that can be imposed by the equipment;
- d) have integral end fittings that allow replacement or maintenance and that enable the connections to be held in position and tightened without the risk of torsional stress being applied to the flexible section;
- e) be routed and retained so that it is unlikely that they can be used as handholds or footsteps

Where there is a possibility of unacceptable hazards arising from leakage onto hot surfaces from flexible pipes additional precautions shall be taken (e.g. by appropriate higher specification, guarding or routing the pipe away from the hot surface).

Flexible pipes for gas systems shall be of corrugated stainless steel or be of a non-metallic construction having a fire-resistant surface.

Corrugated stainless steel hoses shall not be used where there is the potential for the entrapment of liquids and contaminants, e.g. within the corrugations or within any inner liner, if unacceptable risk exists.

### 5.23.11 External fire

Where the potential exists for pressure equipment to be subjected to external fire, appropriate protective measures shall be taken to minimize risks in the event of leakage.

### 5.23.12 Material embrittlement and corrosion

Where, under reasonably foreseeable circumstances, equipment can contain gas or other media under pressure that can be contaminated, with the potential for causing embrittlement of the pressure containing parts, materials that provide a tolerable level of resistance to cracking shall be selected.

Attention shall be given to the potential for accelerated embrittlement where contaminants can interact to accelerate the corrosion process (e.g. the presence of hydrogen sulfide with trace contaminants of mercury).

NOTE ISO 15156-1:2001 provides guidance on the selection of materials resistant to stress corrosion cracking in the presence of hydrogen sulfide at different levels of contamination, pressures and temperatures.

Measures shall be taken to monitor temperatures and pressures to ensure that they are within the ranges that were used for the selection of a given material.

Consideration shall be given to drying and heating gases to reduce the potential for the presence of liquids with the potential to cause corrosion and thereby mitigate the potential for material failure.

### 5.23.13 Ultra-violet (UV) resistant pipework

Non-metallic hoses and pipework shall not be used where strong concentrations of UV light can occur, with the potential for premature degradation of the material.

## 5.24 Auxiliary systems

### 5.24.1 Lubrication systems

The lubrication oil system shall fulfil the requirements for oil flow, pressure and temperature required by the gas turbine. Loss of pressure and temperature control functions that can lead to a dangerous situation shall be detected so that shut-down with a tolerable risk can be achieved.

If an external seal air supply is necessary, on gas turbine shut-down, to prevent the internal leakage of oil from the gas turbine bearings to areas of high temperature within the gas turbine core which could create a fire risk, the specification of the seal air supply shall be such that the supply is maintained under all reasonably foreseeable circumstances for a period that allows the internal gas turbine surfaces likely to be in contact with the oil to cool below a temperature at which ignition can take place.

Where a fan assisted coalescer is used for mist removal, and a hazardous situation can arise from an increase in back pressure, a bypass or other measures shall be taken to reduce the back pressure to the design limit.

Electrostatic charging and the formation of sparks in the lube oil system, which can lead to a dangerous condition, shall be prevented by sufficient electrical conductivity of the oil or by appropriate system parts, in particular, in relation to isolated conductors and non-conductive parts, such as filter elements.

### 5.24.2 Water systems

Where water systems (e.g. wash, injection, evaporative cooling, air inlet direct water mist spray and fire protection) are located where there is the risk of freezing, measures shall be taken to avoid equipment failure. Such measures may include

- a) the use of an appropriate anti-freeze additive;
- b) trace heating of exposed equipment and pipe work with associated thermal insulation;
- c) the use of suitable methods to prevent freezing of fluids in drain tanks where the lack of drainage can induce a hazard.

Solvents used to enhance the properties of the wash fluid during on-line gas turbine compressor cleaning and anti-freeze additives shall be selected so that a mixture capable of ignition or of producing a rapid increase in gas turbine combustion temperatures is not used. Off-line gas turbine compressor washing utilizing solvents and anti-freeze shall be followed by a flushing, drying and purging cycle to ensure that no harmful or combustible deposits remain.

The quality of water used for gas turbine compressor air inlet evaporation cooling or direct water mist injection, gas turbine compressor water wash, primary or secondary water injection and the source for steam injection shall be controlled such that the total contaminants entering the gas turbine shall not impair the life of components, leading to premature failure and a potentially hazardous situation.

### **5.24.3 Hydraulic and pneumatic systems**

Hydraulic and pneumatic systems shall comply with the safety requirements of ISO 4413:1998, 4.3, and ISO 4414:1998, 4.3, respectively.

### **5.24.4 Utility supplies**

Utility supplies shall be filtered and have any undesirable condensate removed to avoid causing malfunction of the supplied equipment.

Instrument utility supply pressure shall be monitored at a point close to the service. The effects of changes in the condition of the utility supply to equipment shall be subject to risk assessment. On the loss of a utility supply, safety equipment shall either permit continued safe operation or shall fail to a safe condition.

Undesirable changes in the pressure of a utility supply shall cause an alarm condition. If the pressure change can cause a potential hazard, the safety devices shall cause shut-down of the equipment. Where it is necessary to maintain pressure to achieve shut-down with a tolerable risk accumulators shall be included in the system.

## **5.25 Installation in a hazardous area**

Hazardous areas shall be classified in zones in accordance with 5.16.2.

Gas turbine installations in zones 0 and 1 areas shall be prohibited. Where the gas turbine is arranged in a ventilated enclosure within a zone 2 area, risk assessment shall take into account the reasonably foreseeable risks.

Installations in zone 2 areas shall comply with the following:

- a) Hazardous area equipment within the zone shall comply with 5.16.4. The equipment shall comply with the requirements of the more hazardous substance inside or outside the enclosure.

NOTE Guidance is given in IEC 60079-10, 4.3, Note 2.

- b) The requirements of IEC 60079-10, 4.4, with respect to extent of zone shall be taken into account.
- c) If within the zone 2 area, the gas turbine compressor air inlet shall comply with 5.9.5 and the ventilation air inlet shall comply with 5.17.6.
- d) Access within the gas turbine enclosure shall be in accordance with the requirements of 7.6.6.
- e) The measures for the prevention of the ignition of flammable gas, vapour or mist on hot surfaces external to the gas turbine enclosure within the zone 2 area, as well as in the enclosure, shall comply with 5.16.4.3.2.
- f) Where the gas turbine exhaust temperature exceeds 80 % of the AIT, in degrees Celsius, of any flammable gas, vapour or mist that can be present, it shall discharge to a safe area taking wind effects into account.

NOTE Based on a site risk assessment, gas detectors may be required at the perimeter of external zoned areas to initiate a gas turbine shut-down if an unacceptable detection level occurs. This might not be part of the packagers supply.

## 5.26 Unenclosed gas turbines in a hall

Hazardous area classification shall be in accordance with 5.16. Zone 0 areas and continuous grades of release in accordance with IEC 60079-10 shall not be permitted in the gas turbine hall.

Any surface temperatures exceeding the AIT of the hazardous gas, vapour or mist that can be present in a zoned area shall be reviewed by risk assessment and suitable mitigation shall be applied. Risk assessment shall take into account the size of the hall and the areas of occupancy with respect to the potential for the ignition of a flammable mixture from a leak source and the possible harm to personnel in the vicinity of the explosion. Where appropriate the techniques described in 5.16.5.3.2 and 5.16.5.3.3 shall be employed in conjunction with appropriate access restrictions.

Any zone 1 areas in the hall shall be limited to the extent arising from reasonably foreseeable release rates that will be diluted by the ventilation to a defined zone that shall not encroach on any equipment not suitably certified or on any surface temperatures that exceed 80 % of the AIT, in degrees Celsius, of any flammable gas, vapour or mist that can be present in the zoned area.

The gas turbine hall shall be fitted with

- a) a fire detection and extinguishant system in accordance with 5.15;
- b) a non-asphyxiant based extinguishant system, or entry to the hall shall be interlocked with isolation of the extinguishant, where personnel access to the hall is required during operation;
- c) a ventilation system assessed in accordance with IEC 60079-10.

Where the potential for an explosive atmosphere exists due to a leak of a flammable gas or vapour, the hall shall be fitted with a gas detection system in accordance with 5.19, but taking into account the need to locate detectors in the vicinity of potential leak sources, credible leak sizes and the effect of ventilation, and the different conditions when starting cold and running hot. Open path detectors should be considered for this application.

NOTE See HSL report CM/99/12 for further information.

## 5.27 Decommissioning and disposal

Gas turbine installations being decommissioned shall be rendered unable to start by at least two methods, such as, for example, removal of starter motive power, removal of control circuit fuses, blinding fuel supply, removal of fuel control valve or disabling the control program.

All systems shall be isolated, tagged and logged. Preservation methods consistent with the future expected use of the engine and systems should be implemented. Noxious or toxic fluids and materials shall be disposed of in a manner approved by the local authority.

# 6 Compliance verification

## 6.1 Quality assurance

Quality assurance shall be achieved by the manufacturer using a recognised quality standard (e.g. ISO 9001:2000).

Design and construction data (e.g. design calculations, engineering drawings), test data, quality control records and records of hazard and operability studies (HAZOPS) and risk assessments shall be kept by the OEM for the equipment life, where there is a legal duty, or otherwise for at least 10 years from the date of supply.

## 6.2 Verification of safety requirements

Compliance with safety requirements shall be verified in accordance with Annex B.

## 7 Information for use

### 7.1 General

Final suppliers shall be responsible for the assembly of safety documentation within their scope of supply, including manuals, drawings and diagrams, that shall be passed to the user before responsibility for their respective installations is passed to the user. Suppliers shall supply the information and recommendations for the transportation, storage, installation, maintenance, operation and training necessary to reduce the health and safety risks and the environmental risks in accordance with ISO 14001 or equivalent to a tolerable level.

Manuals and documentation may be provided in whole or part in electronic format.

### 7.2 Language

Safety related documentation shall be drawn up in the base language selected by the OEM from which any translations are developed.

Safety related documentation shall be issued in the language agreed with the purchaser and/or other languages demanded by local legislation. By way of derogation from this requirement, the maintenance manuals and commissioning documentation for use by specialist personnel need only be available in a single language understood by those personnel.

### 7.3 Packaging

Where the gas turbine core is being packaged and installed by a third party, or other combinations are adopted for the supply of the finished installation, the appropriate safety related documentation and manuals shall be supplied along the supply chain to ensure that a tolerable level of safety is achieved. This shall be achieved by the supply of technical documentation and manuals that define the interfaces, their functions and the actions being taken with respect to safety for all the equipment as design, assembly, installation and commissioning progresses through the supply train. Where applicable documentation shall also include information relating to residual risks necessary for risk assessments undertaken in the supply chain or by the operator.

### 7.4 Commissioning

Commissioning documentation, which supplements other manuals where additional information is necessary for the commissioning of safety devices and their associated functions, shall be available. The documentation shall include details of checks that shall be undertaken on the equipment, safety devices and associated control system functions prior to first gas turbine start-up, including checks that the control-system parameters applicable to safety functions are correctly adjusted/set. Changes made during commissioning shall be within criteria that have been validated to allow non-hazardous operation.

Loop checks, including resistance to earth and continuity, shall be carried out for each applicable safety device including, where applicable, calibration of the device. Where a device is still within its calibration period this may be carried out by simulation of the device output. Where use is made of distributed networked controls and the loops have been validated at the manufacturer's works for both the devices and the controls and the equipment is within calibration, the loop check may be replaced by a communications check. Power supplies for safety devices, including those supplied and installed by the operator, shall be checked to ensure that the voltage and current supplied and protection and isolation of the circuit are in accordance with the documentation.

The documentation shall include details of bonding, earthing and shielding checks that shall be undertaken with respect to safety devices and associated wiring where the devices are susceptible to static electricity or electrical interference. The documentation shall include details of bonding and earthing checks that shall be undertaken on mechanical equipment with flowing media or that is otherwise subject to the build up of static electricity that can affect the operation of safety devices, lead to ignition in a hazardous area or cause static shocks to personnel.

The documentation shall designate the piping connections to all safety related supply, vent and drain lines and tanks and shall state that during the commissioning process, these shall be checked for proper function and, where necessary, that the associated flow rates, pressures and temperatures are within limits and that associated safety devices, pressure equipment assemblies and locking devices are correctly installed and calibrated and function correctly. Checks shall include verification that each gas vent has the opening required by the design (this may include a restriction orifice), that it has been correctly connected to the relief system or atmosphere and has been terminated in a safe location with respect to any hazardous zones.

The documentation shall state that hazardous areas shall be reviewed by the operator to ensure that, where applicable, equipment is correctly certified for the zone and that zones are not compromised by such hazards as gas vents, other sources of potentially explosive leakage or hot surfaces.

The documentation shall include the necessary checks to verify that site installed fire protection equipment has been assembled and located correctly. This shall include checks that pressurized extinguishant and propellant bottles are located such that overheating will not occur and burst disc debris and discharges are directed to a safe location. Where an extinguishant discharge test is required after installation, the documentation shall include the procedure to be adopted and the safety precautions to be taken, including those where the test is undertaken from running conditions and any post-test inspections that may be required.

Pre-start checks (cold commissioning) shall include exercising of valves and other devices that are part of a safety function and checking that the equipment is correctly mounted and aligned. Where applicable, running tests shall be undertaken to verify that safety devices are operating correctly.

Where x-rays or gamma rays are used for inspection, diagnostics, or calibration, the documentation shall include precautions to be taken to protect personnel and sensitive equipment from harm.

The documentation shall state that for starting systems having common starting capabilities for multiple units, proper electrical and mechanical interlocks shall be tested prior to commissioning in order to avoid starting the wrong gas turbine.

## 7.5 Operation

### 7.5.1 General

A manual shall be provided to enable the equipment to be operated with tolerable risk. This shall identify any conditions that impose limitations on the usage of the equipment and any procedures required before and after defined periods of shut-down.

The manual shall contain a description of each section of the equipment, its function and safe operating criteria, the associated safety devices and interlocks and safety check procedures and any limitations on use. The description shall include, where applicable, the operating sequences of equipment during start-up, changes in operation and shut-down, the locations of emergency stop devices and methods for tracing and eliminating minor faults.

The manual shall contain instructions for the checking of safety related devices and inspections and setting checks that should be undertaken whilst the equipment is in use.

The manual shall identify any site specific reasonably foreseeable environmental conditions that can effect the safe operation of the equipment and the associated corrective actions.

The control system section of the manual shall describe the function of the control system, the equipment operating concept and modes, and how the annunciation of start, operation and shut-down sequences, the machine status and fault conditions are arranged and displayed. The manual shall include a description of any start-up warning devices, hold-to-run devices and how the machine will react after the actuation of safety devices. Where a message requires operator intervention the actions required shall be clearly indicated or described in the manual. The manual shall describe any actions that should be taken before accepting an alarm condition and before resetting after a trip.

Where manual intervention is required for testing of the safety functions and devices during normal operation the periodicity and the actions required shall be described in the manual.

### **7.5.2 Safety instructions and emergency procedures**

The manual shall contain safety instructions required to ensure that the machinery is operated safely under reasonably foreseeable operating conditions and actions to be taken in the event of a reasonably foreseeable emergency and warning against any potential misuse of the equipment.

Where required by local legislation a declaration should be provided detailing the airborne noise emission based upon measurements made using the method defined in ISO 10494:1993. The declaration shall comply with ISO 4871:1996.

The manual shall contain warnings and refer to material safety data sheets (MSDS) for all hazardous substances/additives approved for normal use during operation of the machine and shall clearly specify any particular working practices and personal protective equipment (PPE) that are necessary to ensure their safe use, including details of acceptable cleaning solutions and of safe working practices during their handling and use. Additionally the manual shall contain information detailing the correct use of the machine to prevent exposure of the operator to harmful substances and any biological hazards. The manual shall provide limitations on the use of flammable anti-freeze agents during gas turbine compressor washing.

NOTE The operator is responsible for keeping the MSDS updated.

The manual shall instruct that regular checks for leaks are undertaken on exhaust ducting and exhaust flexibles where these are routed through a building where leakage can lead to asphyxiation of personnel in or passing through the building (see 5.12.3). A description of the characteristics of any vents, exhausts or drains for hazardous and noxious substances shall be included. Where the potential exists for contact with or inhalation of toxic gases, the manual shall contain information on the use of portable gas detectors in conjunction with site procedures to cope with any leakage.

The manual shall include instructions on the actions taken by the operators in the event of a gas or mist detector alarm where fitted. Where automatic or manual processes exist to change the ventilation rate on the detection of a leak, the process shall be described in the manual together with details of the effects of its use on the gas or mist detection equipment. If more than one detector is provided, the manual shall include instructions on the interpretation of each detector reading. The manual should also include the actions and precautions to be taken to locate and eliminate the source of a leak, including details of the equipment to be used, and limitations on access when a leak is known to be present. Where the incorrect operation of manual drain or vent valves can cause a hazardous situation, the manual shall contain clear instructions on their operation.

Hot surfaces in hazardous areas should be maintained free of contaminants that can ignite or contaminants that can affect the ignition characteristics of the surface.

The manual shall include instructions on the action taken by the operators in the event of fire detection, for both fire detected automatically and fire detected by the operators, and details of any additional actions associated with manual release of the fire extinguishant at the extinguishant containers. Where manual actuation of the emergency release is required at the extinguishant containers, the operating manual shall advise that the emergency stop button shall be activated to cut off the fuel supply. The manual shall also take account of the risks in the opening of enclosure doors after extinguishant discharge, including those associated with the inrush of air and the potential for re-ignition or explosion.



The manual shall include details of all actions required for system replenishment after extinguishant release, including any inspection and maintenance procedures that shall be followed to ensure that subsequent operation is achieved successfully.

The manual shall contain warnings and precautions that should be taken where there is the potential for discharge of extinguishant from inadvertent operation of UV or other similar detectors from external interference.

The manual shall include instructions on how to confirm the integrity of the equipment for subsequent operation with tolerable risk after any emergency shut-down.

The manual shall include instructions covering any necessary inspection, stabilization and re-setting actions that should be taken prior to a gas turbine restart in the event that a turbine compressor surge event has occurred.

## **7.6 Enclosure access**

### **7.6.1 General**

The manual shall provide instructions covering access to the gas turbine and all other enclosures during operation, maintenance and commissioning based on the requirements shown in 7.6.2, 7.6.3, 7.6.4 and 7.6.5, including that prior to entry to any enclosure protected by a fire suppressant system capable of asphyxiation or other hazards, the release of the suppressant shall be mechanically isolated and locked off. Electrical isolation may be permitted for short term entry in large spaces with easy means of egress where this cannot be overridden by manual release. In confined spaces, mechanical isolation shall be applied.

The manual shall contain instructions for the safe opening of machinery enclosure doors ventilated by positive pressure to prevent impact hazards and the safe closure of negatively ventilated machinery enclosure doors to prevent crushing hazards, and shall state that enclosure doors shall be correctly closed after maintenance, or any other opening of the doors, to obtain the correct integrity of any enclosure protected by an extinguishant gas.

The manual shall contain instructions on the conditions required for access, taking into account the internal conditions such as noise levels, presence of any hazardous gas, internal temperature levels and temperature distribution.

The manual shall include guidance, where appropriate, on the use of an additional person who should be present external to the enclosure to monitor activities and take any emergency action if a hazardous situation arises. Where the enclosure door is closed the additional person should monitor activities from a position local to the door with line of sight to the activity being undertaken. The additional person shall have mechanisms and means to monitor personnel within the enclosure. Where line of sight cannot be achieved other methods shall be used to enable an alarm to be raised if an incident occurs.

### **7.6.2 Risk assessment for accessing enclosures**

Opening of the enclosure doors and any subsequent entry should be under the control of a written PTW (permit to work) system which shall also detail PPE suitable for the given task. This should include a risk assessment that takes into account at least: changes in the ventilation airflow, the presence of flammable leaks, the risk of ignition, entrapment, slips, trips and falls, thermal and noise hazards, egress restriction in the surrounding area, potential for doors to freeze closed during access, and lighting. An additional person shall be present during access in accordance with 7.9.

Where access in the enclosure is being undertaken no egress restrictions shall be in place in the surrounding areas. Where emergency lighting is not provided entry should not be undertaken unless natural ambient lighting provides adequate visibility for exit or uninterruptible temporary lighting is installed.

### 7.6.3 Limitations under operational conditions

Access to the gas turbine enclosure followed by door closure shall be prohibited under running conditions, unless access routes are provided for routine maintenance activities and adequate methods of escape exist, with provision for opening enclosure doors against ventilation loads. Access shall be permitted only when steady state running conditions have been established and no alarm condition exists that can escalate into a hazardous situation or where other reasonably foreseeable or planned changes in operation can occur. The small variations that occur during normal running are not considered to increase risk.

### 7.6.4 Limitations under non-operational conditions

A section of the manual shall address conditions for access to the gas turbine enclosure under non-operational conditions. The gas turbine and other machinery appropriate to the task to be undertaken shall be interlocked from starting. Pressurized systems applicable to work to be undertaken shall be depressurized/vented and appropriately isolated.

Where access under non-operational conditions is necessary followed by closure of the enclosure doors the availability of lighting within the enclosure shall be assured through the availability of permanent or temporary emergency lighting. Where such access is undertaken with the ventilation system operational and with ventilation loads on enclosure doors, additional precautions shall be taken (e.g. ventilation control from within the enclosure, radio communication) to prevent entrapment of personnel.

### 7.6.5 Access during commissioning and re-commissioning

Where special access is necessary during initial commissioning or re-commissioning after overhaul or modification, such access shall be undertaken only by appropriately qualified and experienced personnel and shall be detailed in the associated commissioning documentation supported by a written PTW in accordance with 7.9.

### 7.6.6 Installations in a hazardous area

See 5.25. In addition to the requirements of 7.6.1 to 7.6.5 access to gas turbine enclosures within hazardous areas shall be prevented during turbine operation and after shut-down unless at least one of the following conditions is fulfilled:

- a) hot surfaces have cooled to below 80 % of the AIT, in degrees Celsius, of any potentially explosive atmosphere;
- b) gas detectors are in use for checking presence of hazardous atmospheres at the point of entry and procedures are in place should a hazardous atmosphere occur during access.

## 7.7 Maintenance

### 7.7.1 General

The manual shall include all of the instructions necessary for maintaining the reliable operation of safety equipment for its intended life. It shall include the replacement of parts whose life is limited by operating hours/cycles. Due consideration should be taken with regards to the fragility, reliability and the importance of the device. See also 5.3 regarding modifications and replacement parts.

Where applicable to ensure reliable and safe operation the manual shall contain instructions detailing the sampling of fluids and information on the need for replacement. Lubricating and hydraulic oil analysis shall be undertaken at defined periods to ensure that deterioration in their properties, which could lead to a hazardous situation, has not taken place.

The manual shall identify the appropriate safeguards that should be taken to enable maintenance activities to be carried out safely including the use of special tooling and fixtures. Safeguards shall cover, where applicable, the hazards arising from gas turbine rotating components (e.g. rotor windmilling), variable geometry and similar mechanisms during maintenance, adjustment and inspection. The use of any devices or lifting equipment to prevent unexpected movement and instability shall be included with recommendations on PTW, isolation and tagging procedures and the posting of warning signs. Where applicable guidance on the use of method statements should be given where the potential for crushing, entrapment or other hazards exist whilst moving equipment.

The manual shall specify all special tools required for the adjustment of safety devices.

### 7.7.2 General maintenance hazards

The manual shall include the precautions required where there is the potential for spark generation in a hazardous area while maintenance work is being carried out, including the shut-off and venting of supplies and checks for the presence of gases prior to and during any work. The provisions to prevent spark generation in the manual shall comply with EN 13463-1:2001.

Where necessary to avoid specific hazards, the manual shall include instructions for the removal and replacement of any guards without damage to components and the necessary isolation procedures to prevent unexpected movement of the guarded equipment, including instructions that guards shall be replaced and, where applicable, correctly sealed before the machine is re-started.

The manual shall detail the acceptable methods for cleaning equipment and shall clearly state if water jets and/or compressed air can be used for cleaning and detail any applicable safeguards.

Additionally, clear instructions should be provided in the maintenance manuals to ensure adequate understanding of the criticality of the parts, and the correct installation methods.

### 7.7.3 Accessibility, isolation and energy dissipation

The manual should include guidance on safe access including the requirement for temporary access platforms required to ensure that the maintenance activity can be executed with tolerable risk. Where the activity is at an elevated level the guidance should include the precautions to be taken against falling objects.

The manual shall describe the safe means provided for the isolation of non-electrical supplies, for the release or depressurization of any stored energy and warning of the risks associated with work on non-purged equipment and the additional safeguards that should be employed (also see 7.8). Diagrams shall be provided showing all valves and other equipment provided specifically for the purpose of the isolation of fluids.

The manual shall describe the means provided for electrical supply isolation, earthing and short-circuit protection, the method of testing, and their proper use for maintenance and repair. Diagrams shall be provided showing all the devices provided specifically for the isolation of electrical supplies. Where maintenance is necessary on energized devices the manual shall include guidance on the methods to be used and supervision, and shall state that before action on the ignition system, variable speed drive controls, or other controls that store dangerous levels of electrical energy, there shall be a wait period to allow the discharge resistances to reduce the energy stored to a non-hazardous level.

The manual shall describe the devices to prevent unexpected start-up or movement, those for the isolation and dissipation of stored energy and their use during gas turbine maintenance and repair as shown in 5.21.2.

Inspection of the lightning protection system shall be undertaken after a known lightning strike.

### 7.7.4 Pressure equipment

The manual shall contain instructions for the inspection and maintenance of pressure equipment to maintain integrity including checking/testing the operation of pressure control and relief devices and the periodicity at which the activities should be undertaken. The instructions shall include checks for wear, erosion, abrasion, corrosion or material degradation where required for continued use with tolerable risk. The manual shall include inspection procedures and change-out periods for flexible pipes, diaphragms and other parts subject to deterioration from continued movement where failure can create a hazardous situation.

The manual shall contain instructions to allow the non-hazardous dismantling of pressure equipment and pipework, including but not limited to the venting/drainage of any residual pressure, any purging required to create an inert atmosphere and associated isolation and blanking. It shall also contain instructions on how to verify the leak tightness of equipment including pressure testing after re-assembly and the precautions taken during testing, including the use of PPE and the risks of asphyxiation from leakage of oxygen-depleting gases used for test purposes. Instructions, where necessary, shall be included for safe filling after assembly and verification of leak tightness.

Where pressure testing is not practical (e.g. between the last fuel shut-off valve and the combustion burners) the manual shall contain alternative procedures to verify that all connects are leak tight. Where indicated as necessary by risk assessment this shall include pressure testing with dummy fittings prior to making final connections.

#### **7.7.5 Fire protection systems**

The manual shall include inspection programmes and maintenance instructions for the total system and its components. The programme shall include the inspection intervals for the different parts of the system such that faults are detected at an early stage to allow rectification before the system may have to operate. Where the system includes fire dampers and their associated controls these shall be included in the inspection programme. The programme should include periodic functional checks that the equipment operates correctly. Non-standard tools required for the maintenance of the fire protection system shall be identified and should be offered as an option.

#### **7.7.6 Gas detectors**

The manual shall include guidance on the maintenance and calibration details for gas detectors in accordance with IEC 60079-29-2:2007, Clause 11, including normal calibration intervals based on the type of detector and its location/usage. The instructions shall include guidance on the test and neutral gases to be used and, where applicable, the required flow rate, the LEL settings used and their relevance to the associated hazard.

The manual shall give guidance on remedial actions taken where calibration checks show changes in reading accuracy that can allow an unacceptable gas concentration to arise. Such action may include shortening of the calibration interval or replacement of the sensor or sensing element. The maintenance procedures shall include verification that the signal from the gas detector gives the correct measurement at the control equipment and that the correct actions are initiated at the set alarm and trip levels.

The use of aerosols, and especially the use of silicone oil mists, shall not be permitted within, and in the vicinity of, the enclosures as they lead to an undetected poisoning of the catalysts such that the safety function of the detection system is ruined without the operators being aware. Maintenance instructions shall include this prohibition.

#### **7.7.7 Control systems: maintenance, calibration and testing**

The manual shall include details of the safety related controls and associated equipment that require functional checks, maintenance, calibration or testing at specified intervals so that the safety integrity level of the safety functions are assured, including those functions that may be calibrated or tested when the engine is running, together with details of any precautions necessary to avoid any hazard arising from the operation of the controls during maintenance. Where applicable the checks shall include a functional test of the safety systems, including safety devices and sensors, that verifies that the control system reacts correctly to the input signals. Calibration shall be completed during commissioning, after any relevant intrusive maintenance and at regular specified intervals. The frequency of the regular calibration shall be as recommended by the manufacturer based on experience and risk assessment.

The manual shall instruct that overspeed protection device(s) shall be subjected to a manual or automatically simulated test, that may or may not interrupt the normal operation, at an interval that validates its functional safety.

Where trend monitoring techniques are utilized to alleviate the need for maintenance activities these shall be subject to risk assessment to ensure that safety is not compromised. The criteria for the safe use of the trend data shall be included in the manual.

### 7.7.8 Hazardous materials

The manual shall contain warnings and details by referring to material safety data sheets (MSDS) for all hazardous substances approved for use during maintenance of the machine and identify any hazardous materials, biological hazards or hazards generated by materials and substances (and their constituents) used or exhausted by the machinery that can be encountered during maintenance and shall clearly specify any particular working practices and PPE that are necessary during all maintenance operations.

Where toxic fuels are used which can leave harmful residues after purging or drainage the manual shall contain instructions for the non-hazardous handling and maintenance of equipment that can become contaminated. The manual shall identify any devices or instruments that need to be provided by the operator, which are considered necessary to detect any hazardous substances or environmental conditions.

## 7.8 Warning signs and notices

Machines shall be provided with markings in accordance with ISO 12100-2:2003, 6.4. Visual danger signs, nameplates, markings and identification plates shall be of sufficient durability to withstand the physical environment involved.

Where access is required to a space when there is the potential for entrapment or where other hazards can exist a warning sign supplemented, if necessary, with text and/or an information sign shall be placed at the point of entry or, if not enclosed, shall be appropriately marked with colour or with fences. Where the space is protected by a fire extinguishant gas that can cause asphyxiation if released the warning sign, supplemented with advisory text, shall be placed in a prominent position covering each point of entry. The text shall advise of the risk of automatic extinguishant release, the need for isolation prior to entry and any safety instructions following a fire shut-down where an inrush of air can create the conditions for re-ignition of an extinguished fire. A warning sign shall be placed at each point of manual release indicating that extinguishant release will occur on activation.

Where additional risk mitigation is required with respect to the opening doors in enclosures with positive or negative pressure artificial ventilation, warning signs shall be positioned at the point of entry.

A warning sign shall be placed at the entry to all areas containing potentially explosive atmospheres. This may be in the form of a hazard warning sign with the letters "Ex" in the triangle or a standard hazard warning sign supplemented by the appropriate text. The solution chosen shall comply with local legislation in the country where the product is put to use.

Where parts or assemblies have to be handled with the aid of lifting equipment during operation and maintenance, the mass shall be marked on the part or assembly to be lifted or referenced on documents included in/with the manuals.

Where appropriate, warning signs used as protection against hot surfaces should include a warning against high temperature and the emission of radiated heat by combining the pictograms for temperature and for the emission of heat by radiation.

Where the considerations in 5.7 or any other requirements show a need for personal ear protection a mandatory warning sign shall be posted at the entries to the area.

Where detailed documentation is not included in the manuals to allow the identification of piping or a piping section and the associated system to which it belongs, the piping as installed shall be marked by painting, lettering, tagging, etc. From the markings, it shall be possible to identify the system to which the piping belongs.

Warning signs shall be placed at points where toxic emissions can occur.

The location of warning/safety signs and notices shall be documented.

## 7.9 Permit to work (PTW)

The operation and/or maintenance manual shall contain guidance on the use of a written PTW system and recommend that such a system is used for activities carried out in hazardous areas, confined spaces, on pressurized equipment, and where supply isolation is required to allow safe working. The manual shall state that it is the responsibility of the operator to issue a written PTW system and should recommend that such work be undertaken by competent and trained persons who fully understand the risks involved and, where necessary, the requirement for a second person to be present who shall maintain close communication during the operation concerned.

## 7.10 Training

Details of the training necessary for personnel involved in the operation, maintenance and commissioning of safety equipment covered by this International Standard shall be available. This should include the functioning of safety devices, their interaction with the controls, the actions that follow an alarm and trip level being activated and any subsequent actions that shall be taken.

IEC 60079-17:2007 and IEC 60079-19:1993 should be used for guidance on the inspection, maintenance and repair requirements for equipment in hazardous areas.

## 7.11 Decommissioning and disposal

Where required by the end operator documentation should include guidance to render the equipment inoperative and guidance on safe decommissioning and disposal of hazardous substances based on the instructions contained in ISO 14123-1:1998.

## Annex A (informative)

### List of significant hazards

Table A.1 lists significant, anticipated hazards together with the significant corresponding preventative measures to reduce or eliminate these hazards. See also Clauses 5, 6, and 7.

**Table A.1 — List of significant hazards**

Hazard	Hazardous situation	Preventative measures	Reference
Lack of safety studies	Devices might not function correctly under all reasonably foreseeable situations	Risk assessment	5.2
Crushing Shearing Cutting or severing Entanglement	Moving parts Uncontrolled movement Fingers trapped during maintenance activity Operator trapped in valves/actuators Clothing trapped in rotating parts	Safe access Guards Isolation/Emergency stop Permit to work Safe distances Warning signs Maintenance	5.8.2, 7.6, 7.8 5.8.1, 7.7.1, 7.7.2 5.21.2, 5.20.8 7.9 5.8.1.1 7.8 7.7
Trapping	Person trapped within an enclosed space and unable to escape Operator trapped in enclosure dampers, potential for severing	Access control Release mechanism Lighting Warning signs Isolation/Emergency stop Permit to work Person in attendance	5.13.9, 7.6, 7.8 5.13.8 5.14 7.8 5.21.2, 5.20.8 7.6.2, 7.9 7.6.1
Impact	Foreign matter in the gas turbine Mechanical disassembly Blade failure	Vibration detection Design for containment Remote safety shut-off valve Traceable materials, testing FOD screen	5.8.7 5.8.15 5.10.5.5, 5.10.6.5 5.8.9 5.8.16
	Foreign matter in the ventilation system followed by violent disassembly of enclosure ventilation fan blades	Guard Design for containment	5.18
	Violent disassembly of air-blast oil-cooler fan, damage to cooler matrix creating potential for fire	Fan location Guard Design for containment	5.18
	High positive/negative enclosure pressure causing uncontrolled door movement/straining forces Entry hazards	Door stays, access control Warning signs	5.13.8, 7.6 7.8
	Icing at gas turbine compressor air inlet causing gas turbine compressor surge	Monitoring, prevention, implosion protection	5.9.3, 5.9.4
	Starter-motor rotor failure	Containment Access control	5.8.18
	Cutting, severing	Sharp edges/corners	Removal/protection of sharp edges, guards
Falling or ejection of objects	Maintenance tools causing sparks in a hazardous zone	Maintenance, atmospheric checks	7.7.2, 5.24.1
	Operator injured by falling objects during periods of maintenance	Training Use of PPE	7.10

Table A.1 (continued)

Hazard	Hazardous situation	Preventative measures	Reference
Break-up: Loss of containment	Fault in driven unit causing violent disassembly	Design Testing	5.8.6 5.8.17
	Failure of high speed rotating components	Design, containment Testing Vibration monitoring	5.8.15, 5.8.17, 5.8.7 5.8.8
High pressure-fluid injection or ejection	Over-pressure in high pressure hydraulic water wash systems, low-pressure gas turbine lubricating oil systems, fuel systems, instrument air supply, and steam-injection supply Over-pressure in fluid lines where fluid is trapped	High-integrity pipework and connectors Monitoring Regulation and relief Inspection Maintenance	5.23, 5.24, 5.10.6.9, 5.23 5.23 7.7.4 7.7.4
Fuel vapour lock	Rupture of pressure equipment containing dangerous media	Design Pressure relief Monitoring	5.10.6.4 5.10.8, 5.23.8.7
Over-pressure ejection	Failure of gas turbine pressure casing containment	Design Thermodynamic design	5.8.3 5.8.15
	Over-pressure in enclosures due to extinguishant discharge Over-pressure in the gas turbine enclosure due to breach of gas turbine pressure casing	Integrity of structure Tests Maintenance Design, test	5.13.2 5.15.6 7.7.4 5.8.3, 5.8.15
	Surge causing over-pressure in the combustion inlet, inlet filter/ducting/flexible fracture and structural failure	Surge margin, control	5.8.4 5.9.2
	Exhaust over-pressure due to uncontrolled exhaust damper closure Pulse in exhaust on shut-down due to engine surge	Monitoring, closing speed control Shielding of flexibles	5.12.1 5.12.2
	Unsafe discharge at gas turbine compressor bleed valve	Routing to a safe location	5.22.4
	Positive pressure in lube oil tank when opening filler, release of carcinogenic oil vapours into the atmosphere	Instructions Warning signs	7.7.8 7.8
	Excess pressure in the fire extinguisher/propellant bottles causing burst disc to blow	High-integrity piping and components Safe location, maintenance	5.23 5.15.11, 7.7.5
Excess pressure from interface to exhaust heat-recovery system	Lack of adequate control with the potential for incorrect operation	Design	5.12.1
Loss of stability of machine or machine parts	Collapsing of parts or equipment	Design	5.8.5
Slip, trip and fall hazards	Falling from a height due to poor access Slippery surfaces, walkway surfaces	Design, maintenance provisions Lighting	5.8.2 5.14
Contact of persons with live parts	Inability to isolate/guard a supply, electrocution	Design, guards Isolation provisions Permit to work Maintenance instructions	5.21.1 5.21.2 7.6.2, 7.9 7.7.3
	Electric shock from stored energy in capacitors	Design Training Warning signs Maintenance instructions	5.21.2.3 7.10 7.8 7.7.3



Table A.1 (continued)

Hazard	Hazardous situation	Preventative measures	Reference
Electrostatic phenomena External influences	Cross interference from wiring Electrical, static and electromagnetic interference causing loss of control Lightning strikes causing short circuit/ malfunction of equipment and loss of control	Design Screening, bonding/ earthing EMC measures Commissioning	5.21.3, 5.21.3.2, 5.21.5  5.21.6, 7.4
Thermal radiation	Thermal radiation from hot casings affecting the safe operation of instrumentation	Design Surveys	5.20.2
Effects from short circuits, overloads, etc.	Generator short-circuit or faulty synchronization causing over-torque	Design, over-torque limiting devices	5.8.6, 5.8.17
Environmental influences on electrical equipment	Water ingress causing short circuit/ malfunction of equipment leading to loss of control, electrocution In ocean coastal areas, build-up of salt from spray	Design Filter, specification	5.21.4 5.17.7, 5.20.2 5.13.1
Damage to equipment from environment contamination	Premature failure of turbine components	Preventative measures Inlet air filtration	5.9.2
Burns, other injuries from contact with temperature	Contact with cold surfaces due to pressure reducing valves or extinguishant/ propellant release Cold surfaces due to expansion of liquid to vapour	Warning signs	5.8.1.2, 7.8
Hot/cold surfaces	Contact with hot/cold surfaces	Guards Warning signs	5.8.1.2 7.8
Damage to health by hot or cold working environment	Chill factors generated by air flow/ ventilation. Overheating due to inadequately insulated hot surfaces and/or poor location of hot air outlets. Prolonged entry in enclosure producing heat stroke	Warning signs Use of Personal Protective Equipment (PPE) Access control	7.8 7.6.2  7.6
Damage to equipment from cold environment	Equipment failure Brittle fracture	Materials Preventative measures	5.8.19
Noise	High noise level from bleed valves, vents and motor exhausts	Location, limit velocity, silencer	5.7
	Noise emission within the environment due to fluid flow	Warning signs Use of PPE	7.8 7.5.2
	Noise levels impairing communications	Silencing, attenuation	5.7
	Noise in the environment due to pulsing of pulse clean inlet system	Pulse timing	5.7
	Interference with speech Less effective communication due to noise levels Hearing loss, due to higher than predicted noise levels	Noise measurements, training Use of PPE	5.7, 7.10 7.5.2
Vibration	Vibration on high speed equipment leading to failure Critical speed encountered in rotating equipment	Design and analysis, monitoring.	5.8.7, 5.8.17
	Vibration of unsupported pipe work, structures, etc. leading to failure	Design	5.23.1, 5.23.2
	Higher-than-permitted velocity of gas through the flexible pipes Potential for rupture	Sizing of flexible pipes	5.23.10
Low-cycle fatigue failure	Premature failure	Design, materials, validation	5.8.8, 5.8.9

Table A.1 (continued)

Hazard	Hazardous situation	Preventative measures	Reference
Low-frequency, radio-frequency radiation, micro-waves	Uncontrolled operation of electrical/electronic equipment due to external interference	Screening, bonding/earthing EMC measures Commissioning	5.21.3 5.21.6 7.4
Infrared, visible and ultraviolet light	Failure of non-metal high pressure hose on extinguishant piping caused by UV degradation	Materials	5.23.13
X- and gamma-rays	Damage to health	Commissioning	7.4
Radiation	Arc or other type of flash causing inadvertent operation of fire detectors causing release of extinguishant	Protection Permit to work Warning signs	5.15.10 7.6.2, 7.9 7.8
Substances	Exposure to high levels of H <sub>2</sub> S from gas fuel. Dangerous substances encountered during operation	Materials of construction Gas detector selection Site procedures Instructions Use of PPE	5.8.9 5.19 5.22.3, 7.8 7.6.2 7.5.2
	Materials subjected to H <sub>2</sub> S contamination failing due to corrosion	Material selection	5.8.9, 5.23.12 5.8.8
Poor identification of piping contents	Inability to identify piping containing dangerous media	Identification of contents	7.8
Contamination	Reverse flow of fluids into service lines causing contamination Fuel contamination of oil	Design, preventative measures	5.10.2, 5.10.7 5.10.8 5.10.4
	Liquid hydrocarbon contamination of gas fuel	Supply Heating	5.6 5.10.2 5.10.4
Asphyxiation	Uncontrolled release of extinguishant inside enclosures/gas turbine hall Smoke within enclosure due to presence of a fire	Isolation, means of escape Access restrictions Use of PPE Discharge warning and signs Instructions	5.15.13, 5.15.6, 5.15.9 7.6 7.8
	Asphyxiation and poisoning due to oxygen depletion by leaks from exhaust with high carbon monoxide content on partial load operation	Exhaust stack height Maintenance	5.12.3 7.7.8
	Asphyxiation by oxygen-depleted atmospheres due to gas leaks during operation or pressure testing	Gas detection Maintenance	5.19 7.7.4
	Asphyxiation due to inadequate venting of battery room	Adequate ventilation	5.21.7
Fire or explosion hazard	Gas leak in enclosures/gas turbine hall	High-integrity pipework and connectors, pressure testing Area classification Ventilation Isolation of supply Minimize sources of ignition Gas detection Fire detection and suppression	5.10.3, 5.23 5.13.4, 5.16, 5.25, 5.26 5.16.5, 5.10.5.2, 5.10.5.5, 5.15.3 5.16.4, 5.17 5.19, 5.13.5 5.15, 5.13.3

Table A.1 (continued)

Hazard	Hazardous situation	Preventative measures	Reference
	Gases or vapours in the gas turbine enclosure prior to start-up Potential for fire and explosion	Purging	5.13.6
	Recirculation of gas turbine ventilation air for anti-icing producing a hazard due to an enclosure fuel leak	Gas detection	5.9.7
	Leak/spray of liquid fuel, hydraulic fluid, lubrication oil onto hot surfaces	High-integrity pipework and connectors Fire detection and suppression Detection of loss for large leaks Isolation	5.23 5.13.7, 5.15 5.15.3 5.10.6.5, 5.15.3.3 5.23.8.5, 5.10.6.2 5.15.3.1, 5.15.2
	Ingestion of explosive gas/hydrocarbon vapours into gas turbine compressor air inlet, enclosure ventilation inlet, generator cooling air inlet Leak of gases into the environment in potentially unsafe areas	Location of inlets and vents Gas detection Area classification Vent location Inlet ducting integrity	5.9.5, 5.17.6 5.16, 5.25 5.22.2 5.17.9 5.9.8
	Deliberate ingestion of excess waste substances	Controls	5.9.6
	Pre-ignition of fuel when in contact with hot internal surfaces at start-up	Fuel used at start-up	5.12.4
	Failure of reverse purge during shut-down from low auto-ignition temperature fuel Explosion/fire on re-start	Purge sequence Fuel used at start-up	5.10.8 5.12.4
	Loss of AC whilst running on low auto-ignition temperature fuel causing purge failure. Explosion/Fire on re-start.	Purge sequence Fuel used at start-up	5.10.8 5.12.4
	Battery gas ignites in battery room	Adequate ventilation	5.21.7
	Over fuelling of gas turbine on light-up	Preventative measures	5.11.2
	Excess fuel leading to danger	Preventative measures	5.10.5.3, 5.10.6.3
	Fuel shut-off valve failure	Strainer Proving/position monitoring	5.10.5.6, 5.10.6.7, 5.10.5.7, 5.10.6.8
	Unignited gases/liquids and vapours internal to the gas turbine/exhaust system/waste-heat boiler	Isolation Purging and draining Safe shut-down	5.10.5.4, 5.10.5.7, 5.10.6.4, 5.12.4 5.11.3
	Failure to detect flame-out while gas turbine is running	Monitoring functions	5.11
	Gas/liquid fuel flowing into a shut-down gas turbine	Safety shut-off valves Venting/draining	5.10.5.1, 5.10.6.1
	In-rush of oxygen into the acoustic enclosure following a fire	Warning signs, instructions	7.8
	Electrical insulation failure	Design Inspection	5.21.1 7.4
	Fire due to incorrect use of solvent wash or other cleaning fluids	Solvent specification	5.24.2, 7.7.8
	Internal oil leak within gas turbine following loss of seal air	Seal air supply specification	5.24.1
	Loss of fire extinguishant leaving no protection	Monitoring	5.15.10
	Leaking acoustic enclosure depleting extinguishant concentration	Integrity test Maintenance	5.15.6, 5.13.1 7.7.5
	Rupture of off-package fuel pipework due to a gas turbine structural failure	Location of shut-off valve	5.10.5.5 5.10.6.5

Table A.1 (continued)

Hazard	Hazardous situation	Preventative measures	Reference
	Potential for fire in lubrication system breather ducting due to close proximity of exhaust ducting	Routing/safe distance Flame arrestor	5.15.3.2
	Loss of ventilation due to icing or other blockage at ventilation inlet	Monitoring	5.17.3, 5.17.7, 5.17.10
	Incorrect use of materials, titanium and magnesium alloys	Design	5.8.9
	Leakage due to incorrect treatment of drains	Design Commissioning, inspection	5.22 7.4
	Detector not sensitive to gas or vapour being detected Gas detection out of calibration	Detector selection, reliability Setting Calibration	5.9.5, 5.19, 7.7.6
	Insufficient water mist by design to extinguish the fire Water mist extinguishant not distributed to all areas of the gas turbine enclosure	Type test	5.15.7
	Freezing of water prevents water mist extinguishant discharge	Anti-freeze, heating	5.15.7
	Blockage of water mist nozzle or system components by rust particles or refill water Blockage of water mist nozzles after discharge	Materials, nozzles filter Water quality	5.15.7
	Manually operated extinguishant isolation valve not open	Position monitoring, annunciation	5.15.6
	Unburnt liquid fuel in exhaust can escalate to an explosion of any fuel vapours	Drains Purging	5.10.9, 5.12.4
	Enclosure ventilation fan failure not detected	Location of monitoring device	5.17.10
	Enclosure dampers fail to close Inert atmosphere within enclosure depleted, potential re-ignition of any fire	Design, position monitoring Maintenance	5.15.6 7.7.5
	Failure to disperse heavier-than-air fuel vapours Potential for vapours to settle in low-level areas/trenches and to migrate to safe areas	Low-level extraction Filling of trenches, gas detection	5.17.4
	Auto-ignition of fuel when in contact with hot internal surfaces during start-up	Fuel for start-up	5.12.4
	Potential explosion of vapours in the drain/vent tanks due to temperature of purge discharge in piping Explosive mixtures in purge lines	Control sequence Purge sequence Flame arrestor	5.10.8 5.10.8 5.10.8
	High breather backpressure due to failed fan in breather coalescer	Bypass arrangement	5.24.1
	No signal to fire extinguishant system, no release	Manual backup release	5.15.6, 5.15.8
	Incorrect treatment of vents and drains causing a dangerous situation	Design Maintenance	5.22 7.7.8
	Incorrect identification of hazardous zones	Area classification	5.16
	Over-temperature in gas starter motor due to supply contamination causing mechanical failure, potential for failure of casing or seals Gas can leak and ignite	Control of supply Strainer	5.8.18

Table A.1 (continued)

Hazard	Hazardous situation	Preventative measures	Reference
	Reverse flow through gas starter motor causing failure	Exhaust outlet design	5.8.18
	Reverse flow from heat recovery to turbine	Preventative measures	5.12.4
	Uncontrolled release from H <sub>2</sub> cooled generators	Enclosure separation	5.13.1
Mechanically generated sparks/hot surfaces	Potential for explosion Sparking of fan blades	Design	5.16.4.3 5.18
Smoke	Poisoning of gas detectors and blinding of fire detectors due to vapours from oil on hot gas turbine surfaces, gaskets and other joints burning in	Gas detector selection Self-checking fire detectors Calibration	5.19.2, 5.15.5, 5.19.6, 7.7.6
	Smoke from cabling due to electrical insulation fault Smoke from fire within acoustic enclosure	Heat detector fitted as a backup to flame detectors	5.21.1 5.15.5
Pollution	General pollution hazard	Materials of construction and methods of use	5.8.9
	Oil mist at breather outlet, potential for carcinogenic exposure, environmental pollution and risk of fire	Oil mist eliminator, flame trap Outlet location	5.15.3.2 5.22
	Pollution due to incorrect treatment of drains Pollution due to incorrect treatment/control of vents	Collection, containment Safe disposal	5.22
	Disposal of product and components at the end of their useful life	Instructions	7.11
	Operation of gas vents	Limited release	5.10.5.5
	Tank overflow	Level monitoring	5.15.3.1
Unhealthy postures or excessive effort	Hard-to-handle components and inadequate lifting provision	Adequate lifting provisions Maintenance instructions	5.8.5, 7.7.1
Neglected use of personal protective equipment (PPE)	Injury	Training Instructions	7.10, 7.6.2, 7.7.8
Inadequate local lighting	Inadequate lighting preventing escape	Lighting	5.14
Mental overload and stress	Inadequate instructions and maintenance	Training, instructions Maintenance	7.10, 7.5, 7.7
Errors made by the operator	Absence or incorrect fitting causing injury or death Human factors leading to incorrect assembly of critical parts Human factors leading to guards missing	Design, features for assembly Training/competence Risk assessment Permit to work Instructions Maintenance	5.8.12 7.10 5.2 7.6.2, 7.9 7.5 7.7
Inadequate design, location or identification of manual controls or visual display units	Incorrect operation	Ergonomics	5.20.3
Combination of hazards	Hazard combinations prevent correct operation of safety devices	Design Analysis	5.6
	Water in the gas, solids in gas, potential for starter motor damage and failure	Supply conditions	5.10.2
	Liquid hydrocarbon condensates in starter motor exhaust when gas supply is near dewpoint	Supply conditions Heating	5.10.2, 5.8.18

Table A.1 (continued)

Hazard	Hazardous situation	Preventative measures	Reference
	Contamination of liquid fuel storage with low auto-ignition fuel. Potential for vapour lock/explosion at fuel burner nozzles, lack of control	Prevention of reverse flow Separate drainage	5.10.8
	Lack of effective hazardous-fuel purging, potential for illness from contaminants	Purging Training Use of PPE Permit to work	5.10.8 7.10 7.6.2, 7.9
	Wax formation in liquid fuel at low temperature, blockage, loss of control	Preventative measures	5.10.2, 5.10.4
Malfunction of control system, software errors	Unexpected operating condition	Design, simulation, testing Functional safety	5.20.1, 5.20.4, 5.20.6
Failure of safety related devices	Fire, explosion, injury to personnel, poisoning, suffocation, etc. due to lack of maintenance	Maintenance	7.7.7
Disorder of controls Unexpected start-up	Machine starts when undergoing maintenance Starting of peripheral equipment while maintenance is being carried out	Start-up control Stop buttons Permit to work EMC measures Isolation	5.21.2.1, 5.20.8, 5.21.2, 7.6.2, 7.9 5.21.6 5.21.2, 5.21.2.1, 5.20.8
Uncontrolled device operation	Injury from inadequate means of prevention	Permit to work	7.6.2, 7.9
Failure/disorder of the control system	Loss of internal temperature control in the gas turbine leading to premature fatigue	Redundancy Measures	5.20.4 5.8.10
	Loss of speed control with the potential for overspeed Loss of effective governing with the potential for over-fuelling	Design for containment Functional safety	5.8.9, 5.8.15, 5.8.17 5.20.7 5.8.18
	Loss of control Uncontrolled operation	Identification of safety related controls Manual intervention	5.20.1, 5.20.8
Valves out of position	Uncontrolled supply, venting or draining of dangerous media	Position monitoring	5.10.8
Lubrication oil supply control	Inadequate lubricating oil supply leading to machinery failure	Control and monitoring	5.24.1
Loss of utility supply	Uncontrolled operation of safety devices	Monitoring Fail-safe design	5.24.4
Failure of energy supplies	Loss of oil supply leading to unsafe shut-down	Backup supplies, fail-safe design	5.21.9, 5.24.1
	Loss of adequate ventilation Failure of detection devices Uncontrolled operation of safety device	Monitoring Battery supply, fail-safe design Functional design	5.17.10, 5.20.1, 5.21.9
	Loss of HVAC to control cabinet	Monitoring of conditions	5.20.2
Restoration of energy supply	Gas accumulation on ventilation failure	Vent Inhibit starts	5.17.10, 5.20.8
Failure of energy supply disconnecting devices	Absence or incorrect fitting can cause injury or death to the operator or bystanders	Design Stored energy	5.21.2 5.21.2.3
External influences, gravity, wind, seismic loads	Structural collapse	Design Integrity of structure	5.1, 5.8.9, 5.8.11 5.12.3, 5.13.2
External influences, winds	Uncontrolled rotation of rotors	Safeguards Maintenance	5.21.2.1 7.7.1

## Annex B (normative)

### Verification of safety requirements and/or measures

In Table B.1, the column heading descriptions are as follows:

- a) **Design verification:** consists of verifying by review of the procedures, technical documentation, test data and any other validation documentation for the applicable equipment or feature that the design complies with the stated requirement;
- b) **Inspection:** consists of visually checking that the machine has the relevant equipment or feature to provide compliance with the stated requirement and/or by the inspection of documentation and certificates to ensure that the appropriate inspection / test procedure has been undertaken;
- c) **Function test:** consists of verifying by functional tests undertaken on each machine or item of equipment that compliance with the stated requirement is achieved;
- d) **Measurement:** consists of verifying that a specific machine parameter or equipment position is monitored within defined limits during operation to achieve compliance with the stated requirement.

“x” signifies that at least one of the verification methods marked “x” or a partial combination of all the identified methods shall be undertaken to provide compliance with the stated safety requirements and/or preventive measures in each paragraph of the clause;

“xx” signifies that the verification method marked “xx” is mandatory to achieve compliance with the stated requirement of the applicable clause where the clause applies to the design of the equipment.

Each clause or subclause of this International Standard shall be reviewed to determine which of the above verification methods as indicated in Table B.1. is applicable to the specific equipment used.

Where there are subclauses to the clauses identified the verification methods defined for the parent clause shall be used.

Table B.1 — Verification requirements

Clause/ subclause	Safety requirements	Design verification	Inspection	Function test	Measurement
5.1	General	x	—	—	—
5.2	Risk assessment	x	—	—	—
5.3	Modifications and replacement parts	x	—	—	—
5.4	Foreseeable misuse	x	x	—	—
5.5	Lifetime	x	—	—	x
5.6	Hazard combinations	x	—	—	—
5.7	Noise	x	—	—	x
5.8	Mechanical				
5.8.1	Guarding	x	x	—	—
5.8.2	Accessibility for maintenance	x	x	—	—
5.8.3	Casing design	x	x	—	x
5.8.4	Gas turbine compressor surge	x	—	—	—
5.8.5	Stability and handling	x	x	—	—
5.8.6	Overload of rotating shafts due to torque	x	x	—	—
5.8.7	Vibration	x	—	x	x
5.8.8	Mechanical failure caused by corrosion	x	x	—	—
5.8.9	Design methods and materials	xx	x	—	—
5.8.10	Gas turbine temperature	x	—	x	x
5.8.11	Environmental load	x	—	—	—
5.8.12	Assembly features	x	x	—	—
5.8.13	Coupling	x	x	—	—
5.8.14	Rotor bearings	x	x	—	—
5.8.15	Rotating part failure	xx	—	x	x
5.8.16	Foreign object damage (FOD) screen	x	x	—	—
5.8.17	Gearbox	x	x	x	x
5.8.18	Starting systems	x	—	x	x
5.8.19	Low ambient temperature conditions	x	x	—	x
5.9	Gas turbine compressor air inlet system				
5.9.2	Inlet air contamination	x	x	—	—
5.9.3	Icing monitoring and prevention	x	x	x	xx
5.9.4	Implosion protection	x	x	x	—
5.9.5	Inlet explosion protection	x	x	—	xx
5.9.6	Waste disposal through combustion	x	x	—	xx
5.9.7	Recirculation	x	x	x	xx
5.9.8	Gas turbine compressor air inlet ducting	x	x	—	—



Table B.1 (continued)

Clause/ subclause	Safety requirements	Design verification	Inspection	Function test	Measurement
5.10	Fuel systems				
5.10.2	Fuel supply quality and supply conditions	x	—	—	x
5.10.3	Pressure testing	x	x	x	—
5.10.4	Fuel supply heating	x	x	—	x
5.10.5	Gas fuel systems	x	x	xx	x
5.10.6	Liquid fuel systems	x	x	xx	x
5.10.7	Multi-fuel systems	x	x	xx	x
5.10.8	Fuel purging	x	x	—	xx
5.10.9	Fuel drainage	x	x	—	xx
5.11	Combustion supervision				
5.11.1	General	x	x	xx	—
5.11.2	Requirements for ignition	x	x	—	x
5.11.3	Extinction safety time	x	x	—	—
5.12	Exhaust system				
5.12.1	Damper controls	x	x	x	x
5.12.2	Flexible joint location	x	x	—	—
5.12.3	Exhaust stack	x	x	—	x
5.12.4	Explosion protection	x	x	—	x
5.13	Enclosures				
5.13.1	General	x	x	—	—
5.13.2	Enclosure structure	x	x	—	—
5.13.3	Enclosure fire precautions	x	x	—	—
5.13.4	Explosion prevention and protection — Area classification — Ventilation	x	x	—	—
5.13.5	Gas detection	x	x	—	xx
5.13.6	Enclosure purging	x	x	x	—
5.13.7	Mist detection	x	x	xx	x
5.13.8	Access and doors	x	x	x	—
5.13.9	Entrapment	x	x	—	—
5.14	Lighting	x	x	x	—
5.15	Fire precautions				
5.15.1	General	x	—	—	—
5.15.2	Structural fire risk reduction	x	x	—	—
5.15.3	Hydrocarbon fire risk reduction	x	x	—	x
5.15.4	Fire protection	x	x	—	—
5.15.5	Fire detection	x	x	x	xx
5.15.6	Fire extinguishing systems	x	x	xx	x
5.15.7	Water mist extinguishant	x	x	x	x
5.15.8	Extinguishing system controls	x	x	xx	x
5.15.9	Escape	x	x	—	—

Table B.1 (continued)

Clause/ subclause	Safety requirements	Design verification	Inspection	Function test	Measurement
5.15.10	Uncontrolled release of media and loss of propellant pressure	x	x	—	xx
5.15.11	Vessel thermal relief (burst disc)	x	x	—	—
5.15.12	Vessel and/or pipe failure	x	x	—	—
5.15.13	Release of extinguishant into gas turbine halls, control rooms, etc.	x	x	—	—
5.16	Hazardous area classification and explosion prevention and protection				
5.16.1	General	x	—	—	—
5.16.2	Area classification	x	—	—	—
5.16.3	Explosion prevention	x	—	—	—
5.16.4	Ignition source control	x	x	—	x
5.16.5	Reduction of explosion effects in an enclosed space	x	x	—	—
5.17	Ventilation				
5.17.1	General	x	—	—	—
5.17.2	Cooling	x	—	—	—
5.17.3	Heating	x	x	—	—
5.17.4	Hazardous area control	x	x	—	—
5.17.5	Hot surfaces	x	x	—	x
5.17.6	Ventilation inlet location	x	x	—	—
5.17.7	Ventilation inlet filtration	x	x	—	x
5.17.8	Ventilation inlet ducting	x	x	—	—
5.17.9	Ventilation outlet location	x	x	—	—
5.17.10	Flow monitoring — Artificial ventilation	x	x	xx	x
5.18	Fans				
5.18.1	Fan guards and structural failure	x	x	—	—
5.18.2	Air blast oil coolers	x	x	—	—
5.19	Flammable gas detection				
5.19.1	General	x	—	—	—
5.19.2	Type/selection principles	x	x	—	—
5.19.3	Location principles	x	x	—	—
5.19.4	Settings	x	x	—	xx
5.19.5	Enclosures containing hot surfaces — Screening tool	x	—	—	—
5.19.6	Maintenance and calibration	x	x	xx	x
5.20	Control and automatic protection systems				
5.20.1	General	x	x	xx	—
5.20.2	Environmental suitability	x	x	—	—
5.20.3	Ergonomics	x	x	—	—
5.20.4	Failure	x	x	x	—

Table B.1 (continued)

Clause/ subclause	Safety requirements	Design verification	Inspection	Function test	Measurement
5.20.5	Calibration	—	x	x	x
5.20.6	Testing	—	x	x	—
5.20.7	Speed control	x	x	x	x
5.20.8	Gas turbine emergency shut-down system	x	x	xx	—
5.20.9	Interlocks	x	—	xx	—
5.21	Electrical				
5.21.1	Design/Installation	x	x	—	—
5.21.2	Isolation and stored energy	x	x	x	—
5.21.3	Electrostatic energy and bonding	x	x	x	—
5.21.4	Water ingress	x	x	—	—
5.21.5	Lightning	x	x	—	—
5.21.6	Electromagnetic compatibility (EMC)	x	x	x	x
5.21.7	Battery	x	x	—	—
5.21.8	Electrical overload	x	x	—	—
5.21.9	Electrical power failure	x	x	x	—
5.22	Drains, vents and bleeds				
5.22.1	General	x	x	—	—
5.22.2	Vents for flammable gases	x	x	x	—
5.22.3	Toxic and hazardous emissions	x	x	x	x
5.22.4	Gas turbine compressor bleeds	x	x	—	—
5.23	Pressure equipment				
5.23.1	General	x	x	x	—
5.23.2	Design	x	—	—	—
5.23.3	Hazards	x	—	—	—
5.23.4	Misuse	x	x	—	—
5.23.5	Safe handling and operation	x	x	—	—
5.23.6	Isolation, draining and venting	x	x	—	—
5.23.7	Fluid injection	x	x	—	—
5.23.8	Assemblies	x	x	x	x
5.23.9	Safety accessories	x	x	x	x
5.23.10	Flexible piping (and metal hoses)	x	x	—	—
5.23.11	External fire	x	x	—	—
5.23.12	Material embrittlement and corrosion	x	x	—	—
5.23.13	Ultra-violet (UV) resistant pipework	x	x	—	—
5.24	Auxiliary systems				
5.24.1	Lubrication systems	x	x	xx	x
5.24.2	Water systems	x	x	xx	x
5.24.3	Hydraulic and pneumatic systems	x	x	xx	x
5.24.4	Utility supplies	x	x	xx	x

Table B.1 (continued)

Clause/ subclause	Safety requirements	Design verification	Inspection	Function test	Measurement
5.25	Installation in a hazardous area	x	x	—	—
5.26	Unenclosed gas turbines in a hall	x	x	—	—
5.27	Decommissioning and disposal	x	x	—	—
6.1	Quality assurance	x	x	—	—
7	Information for use	x	x	x	—

## Bibliography

- [1] AGMA 6011, *Specification for High Speed Helical Gear Units* <sup>3)</sup>
- [2] AGMA 6023, *Design Manual for Enclosed Epicyclic Gear Drives*
- [3] ANSI B11.TR3-2000, *Risk Assessment And Risk Reduction — A Guide To Estimate, Evaluate And Reduce Risks Associated with Machine Tools*
- [4] API 613:2003, *Special Purpose Gear Units for Petrochemical, Chemical and Gas Industry Services* <sup>4)</sup>
- [5] EN 614-1:2006, *Safety of machinery — Ergonomic design principles — Part 1: Terminology and general principles*
- [6] EN 14461:2002, *Industrial fans — Safety requirements*
- [7] EN 1838:1999, *Lighting applications — Emergency lighting*
- [8] HSL report CM/03/12, *Outstanding safety questions concerning the analysis of ventilation and gas dispersion in gas turbine enclosures: Best Practice Guidelines for CFD* <sup>5)</sup>
- [9] HSL report ECO/03/06, *Outstanding safety questions concerning the analysis of ventilation and gas dispersion in gas turbine enclosures: Best Practice Guidelines on in-situ testing* <sup>3)</sup>
- [10] HSL report CM/04/09, *Outstanding safety questions concerning the use of gas turbines for power generation — Summary report* <sup>3)</sup>
- [11] HSL report CM/99/12, *A study of the consequences of leaks from gas turbine power plant sited in a turbine hall* <sup>3)</sup>
- [12] IEC 60079-19:2006, *Explosive atmospheres — Part 19: Equipment repair, overhaul and reclamation*
- [13] IEC 60812:2006, *Analysis techniques for system reliability — Procedure for Failure Mode and Effects Analysis (FMEA)*
- [14] IEC 62305-1:2006, *Protection against lightning — Part 1: General principles*
- [15] IEC 61025:2006, *Fault tree analysis (FTA)*
- [16] IEC 61511-3:2004, *Functional safety — Safety instrumented systems for the process industry sector — Part 3: Guidance for the determination of the required safety integrity levels*
- [17] IEC 61882:2001, *Hazard and operability studies (HAZOP studies) — Application guide*
- [18] IEC 61508-5:1998, *Functional safety of electrical/electronic/programmable electrical safety integrity levels*

---

3) American Gear Manufacturers Association.

4) American Petroleum Institute.

5) Health and Safety Laboratory, Buxton, UK. HSL reports are available as free downloads from the HSL website <http://www.hsl.gov.uk>.

- [19] IGE/SR/15, *Integrity of safety related applications in the gas industry*, Edition 4, 2005 <sup>6)</sup>
- [20] IP-MCSP-P15, *Model code of safe practice — Part 15: Area classification code for installations handling flammable fluids* <sup>7)</sup>
- [21] ISO/IEC Guide 51:1999, *Safety aspects — Guidelines for their inclusion in standards*
- [22] ISO 9001, *Quality management systems — Requirements*
- [23] ISO 9972:2006, *Thermal performance of buildings — Determination of air permeability of buildings — Fan pressurization method*
- [24] ISO 13691:2001, *Petroleum and natural gas industries — High speed special-purpose gear units*
- [25] ISO 13732-1:2006, *Ergonomics of the thermal environment — Methods for the assessment of human responses to contact with surfaces — Part 1: Hot surfaces*
- [26] ISO 13732-3:2005, *Ergonomics of the thermal environment — Methods for the assessment of human responses to contact with surfaces — Part 3: Cold surfaces*
- [27] ISO 15156-1:2001, *Petroleum and natural gas industries — Materials for use in H<sub>2</sub>S-containing environments in oil and gas production — Part 1: General principles for selection of cracking-resistant materials*
- [28] NFPA 70:2007, *National Electrical Code*
- [29] NFPA 101:2005, *Life Safety Code*
- [30] NFPA 497:2004, *Classification of Flammable Liquids, Gases or Vapors and of Hazardous (Classified) Locations for Electrical Installations in Chemical Process Areas*

---

6) Institution of Gas Engineers and Managers.

7) Energy Institute, UK.

Index

<b>A</b>	<b>B</b>	<b>C</b>	<b>D</b>	<b>E</b>
Access	Base frames..... 9	Casing	Control systems..... 41	Electrical..... 43
commissioning .....58	Batteries .....45	air or gas leakage ..... 34	calibration ..... 41	batteries..... 45
compressor bleeds.....13	Bearing supports..... 9	blade failure ..... 9	design and installation ..... 43	design ..... 43
control as a guard .....8	Blade failure..... 9, 12	design ..... 9	environmental suitability ..... 41	electromagnetic compatibility
emergency stop.....42	Bleeds.....45	gearbox.....12	equipment casing leakage ..... 34	(EMC)..... 44
enclosures .....28	compressor ..... 13, 46	Pressure Equipment Directive	ergonomics ..... 41	electrostatic ..... 44
entrapment.....28	burn threshold temperatures ..... 8	exclusion ..... 47	failure.....41	installation ..... 43
explosion relief .....36		rupture ..... 10, 11	interlocks ..... 43	isolation ..... 43
for leak detection .....56		stability..... 9	maintenance ..... 60	lightning ..... 44
hot surfaces.....8		starter motor ..... 13	speed control ..... 42	overload..... 45
information for use .....57		temperature ..... 10	testing ..... 41	
installation in a hazardous area..52, 58		testing ..... 9	Cooling	
maintenance.....8		Chemical Agents Directive..... viii	compressor inlet ..... 14	
manual drain valves .....46		Classification, Packaging, and	gas turbine..... 10	
noise.....8		Labelling of Dangerous Substances	ventilation ..... 37	
permit to work.....57		Directive..... viii	Corrosion	
pressure equipment misuse .....47		Closed cycle ..... See Scope	design allowance ..... 47	
starter .....13		Cold surfaces..... 8	fatigue limit ..... 10	
toxic emissions .....46		Combustion supervision ..... 24, 41	pressure equipment..... 50	
turbine hall.....53		extinction safety time ..... 25	stress accelerated grain boundary	
warning signs .....61		ignition safety time ..... 24	oxidation (SAGBO)..... 10	
water-mist nozzles .....31		Commissioning	stress corrosion cracking ..... 10	
Accessibility		access..... 57, 58	Couplings ..... 11	
controls.....48		control systems calibration..... 60		
fuel isolation ..... 18, 21		control systems testing ..... 42		
maintenance.....8, 59		information for use ..... 54		
Accumulators .....49, 52		pressure testing on running gas		
Air-blast coolers .....39		turbine ..... 16		
AIT		starting systems..... 13		
definition.....4		ventilation validation..... 37		
ALARP .....7		ventilation validation..... 37		
Area classification .....34		Compressor air inlet..... 13		
enclosures.....27, 35		contamination ..... 13		
installation in a hazardous area..52		ducting ..... 15		
turbine hall.....53		explosion protection ..... 14		
vent line joints .....46		gas detection ..... 14, 15		
ventilation .....38		icing ..... 13		
warning signs .....61		implosion protection ..... 14		
Assembly features..... 11		installation in a hazardous area ..52		
air-blast coolers .....39		location ..... 38, 46		
pressure equipment .....29, 60		recirculation ..... 15		
pressure testing.....16		waste disposal ..... 14		
ATEX (Equipment) Directive ..... viii		Compressor bleeds..... 13, 46		
ATEX (Workplace) Directive..... viii		Compressor surge ..... 9, 15, 37		
Auto-ignition temperature		Computational fluid dynamics (CFD)		
data .....35		..... 36		
definition.....4				
driven machinery .....26				
enclosure purging.....27				
explosion prevention .....27				
explosion protection .....25				
inlet-air flows .....15				
leak impingement .....29				
low values .....29				

power failure ..... 32, 45  
power restoration ..... 45  
sources of ignition ..... 35  
stored energy ..... 43  
stray current ..... 44  
water ingress ..... 44  
Electromagnetic compatibility (EMC)  
..... 44  
Electromagnetic Compatibility  
Directive ..... viii  
Electrostatic ..... 44  
Embrittlement  
pressure equipment ..... 50  
Emergency procedures  
information provision ..... 56  
Emergency shutdown  
information provision ..... 57  
Emergency stop ..... 29, 42, 43, 55  
Enclosures  
access ..... 28, 58  
access, information for use ..... 57  
area classification ..... 27  
doors ..... 28  
electrical ..... 44  
entrapment ..... 28  
explosion protection ..... 35  
fire precautions ..... 27  
gas detection ..... 27, 40  
lighting ..... 28  
mist detection ..... 27  
outdoor ..... 26  
purging ..... 27  
structure ..... 26  
ventilation ..... 37  
Energy storage plants ..... See Scope  
Engine temperatures ..... 10  
Environment ..... 1, 6  
disposal ..... 53  
low ambient temperatures ..... 13  
toxic emissions ..... 46  
Environmental loads  
ice ..... 10  
snow ..... 10  
wind ..... 10  
Environmental Noise Directive ..... viii  
Environmental suitability ..... 41  
Exhaust system ..... 25  
damper controls ..... 25  
explosion protection ..... 25  
flexible joint location ..... 25  
location ..... 55  
purging ..... 25  
Explosion prevention ..... 34  
hot surfaces ..... 35  
ignition source control ..... 35  
Explosion protection ..... 34  
compressor air inlet ..... 14  
dilution ventilation ..... 36  
enclosures ..... 35  
exhaust system ..... 25  
explosion relief ..... 36  
suppression ..... 37

Explosion relief ..... 36  
Explosion suppression ..... 37  
Extinction safety time ..... 25  
definition ..... 4

**F**

Fans  
Air-blast coolers ..... 39  
guarding ..... 39  
Fire detection ..... 30  
Fire precautions ..... 28  
enclosures ..... 27  
escape ..... 33  
extinguishing system controls ..... 31  
extinguishing systems ..... 30  
hydrocarbon risk reduction ..... 29  
lubrication and hydraulic systems ..... 29  
structural ..... 28  
uncontrolled release ..... 33  
Fire protection ..... 29  
detection ..... 30  
maintenance ..... 60  
pressure equipment ..... 50  
rotor bearings ..... 11  
turbine hall ..... 53  
Fire-extinguishing systems ..... 30  
carbon dioxide ..... 30  
gases ..... 30  
release into occupied areas ..... 34  
thermal relief ..... 33  
vessel or pipe failure ..... 33  
water mist ..... 30  
water sprinkler and spray ..... 30  
Flammable gas detection ..... See Gas  
detection  
Flexible metal hose ..... 50  
Flexible pipe ..... 50  
maintenance ..... 59  
Floating production platforms ..... See  
Scope  
Floating production units ..... 10  
Floating production, storage and  
offloading vessels ..... 10  
Fluid injection  
to the human body ..... 48  
Foreign object damage ..... 12  
implosion protection ..... 14  
FPSO ..... 10  
FPU ..... 10  
Fuel systems ..... 15  
combustion supervision ..... 24  
heating ..... 16  
multi-fuel systems ..... 23  
pressure testing ..... 16  
purging ..... 23  
supply quality and conditions ..... 15

**G**

Gas detection ..... 39  
compressor inlet ..... 14

enclosures ..... 27  
installation in a hazardous area ..... 52  
location ..... 40  
screening tool ..... 40  
selection ..... 39  
turbine hall ..... 53  
ventilation validation ..... 36

Gas detectors  
maintenance ..... 60  
settings ..... 40  
Gas fuel  
flow control ..... 19  
isolation ..... 18, 21  
isolation outside the package ..... 19  
shut-off ..... 19  
strainer ..... 19  
valve proving ..... 20  
Gearbox ..... 1, 12  
casing ..... 12  
overload ..... 12  
Guarding ..... 8  
blade failure ..... 9  
cold surfaces ..... 8  
fans ..... 39  
hot surfaces ..... 8, 50

**H**

Hazardous materials  
information for use ..... 61  
Heating  
ventilation ..... 37  
Hot surfaces ..... 8, 35  
additional measures ..... 38  
fluids with low AIT ..... 29  
guarding ..... 8  
in a hazardous area ..... 52, 55, 58  
inlet filtration ..... 38  
leaks ..... 29  
lubrication and hydraulic oils ..... 29  
re-ignition ..... 31  
screening tool ..... 40  
warning signs ..... 61  
Hydraulic systems  
fire precautions ..... 29  
maintenance ..... 58  
pressure equipment ..... 52

**I**

Ice ..... 10  
Ignition safety time ..... 24  
definition ..... 4  
Ignition source control ..... 35  
electrical sources ..... 35  
non-electrical sources ..... 35  
Information for use ..... 54  
commissioning ..... 54  
decommissioning and disposal ..... 62  
emergency procedures ..... 56  
hazardous materials ..... 61  
language ..... 54  
operation ..... 55



packaging ..... 54  
 permit to work ..... 57  
 safety instructions ..... 56  
 training ..... 62  
 warning signs and notices ..... 61  
 Installation in a hazardous area ..... 52  
   access ..... 58  
 Integrated Pollution Prevention and  
 Control Directive ..... viii  
 Interlocks ..... 43  
   definition ..... 4

**L**

Language  
   information for use ..... 54  
 LEL  
   definition ..... 4  
 Lifetime ..... 7  
   definition ..... 4  
 Lifting ..... 9  
 Lighting  
   design ..... 43  
   escape ..... 33  
 Lightning protection ..... 44  
 Liquid fuel  
   drain valve ..... 22  
   drainage ..... 24  
   shut-off ..... 22  
   strainer ..... 23  
   thermal relief ..... 23  
   valve proving ..... 23  
 Low Voltage Directive ..... viii  
 Lower explosive limit  
   definition ..... 4  
 Lubrication systems  
   fire precautions ..... 29  
   pressure equipment ..... 55  
   shutdown ..... 29

**M**

Machinery Directive ..... viii  
 Magnesium ..... 10  
 Maintenance ..... 8, 60  
   accessibility ..... 62  
   control systems ..... 60  
   fire protection ..... 60  
   gas detectors ..... 60  
   hazards ..... 59  
   pressure equipment ..... 59  
 Material safety data sheets ..... 56, 61  
 Mist detection ..... 27  
 Misuse ..... 7  
   information provision ..... 56  
   pressure equipment ..... 47  
 Modifications ..... 7  
 MSDS ..... 56, 61

**N**

Noise ..... 8

**O**

OEM  
   definition ..... 5  
 Offshore applications ..... See Scope  
 Operation manual ..... 55  
 Operator  
   definition ..... 4  
 Original equipment manufacturer  
   definition ..... 5  
 Over speed  
   starting system ..... 12  
 Overload  
   electrical ..... 45  
 Overload of rotating shafts due to  
   torque ..... 9  
 Over-speed  
   detection ..... 41  
   protection ..... 42

**P**

Packager  
   definition ..... 5  
 Packaging  
   information for use ..... 54  
 Permit to work  
   information for use ..... 57, 62  
 Personal protective equipment 56, 57,  
   60, 61  
 Pneumatic systems  
   pressure equipment ..... 52  
   pressure testing ..... 16  
 Power failure  
   electrical ..... 45  
 Power restoration  
   electrical ..... 45  
 Pressure equipment ..... 47  
   accumulators ..... 49  
   assembly features ..... 29, 60  
   assemblies ..... 48  
   corrosion ..... 50  
   design ..... 47  
   drainage ..... 49  
   draining ..... 48  
   embrittlement ..... 50  
   external fire ..... 50  
   filling ..... 49  
   flexible pipe ..... 50  
   fluid injection ..... 48  
   handling ..... 47  
   hydraulic systems ..... 52  
   isolation ..... 48  
   lubrication systems ..... 51  
   maintenance ..... 59  
   misuse ..... 47  
   operation ..... 47  
   particulate contamination ..... 49  
   pneumatic systems ..... 52  
   pressure testing ..... 16  
   pressure-limiting devices ..... 50  
   pumps ..... 49  
   quick release ..... 49

safety accessories ..... 49  
 thermal safety ..... 50  
 ultra-violet resistance ..... 51  
 utility supplies ..... 52  
 venting ..... 48  
 water systems ..... 51  
 Pressure Equipment Directive ..... viii  
 Pressure testing  
   casing ..... 9  
   fuel systems ..... 16  
   information provision ..... 60  
 Propulsion ..... See Scope  
 Pumps ..... 49  
   liquid fuel ..... 22  
 Purchaser  
   definition ..... 5

**Q**

Quality assurance ..... 53  
 Quick-release connections ..... 49

**R**

Relief valve  
   definition ..... 5  
 Replacement parts ..... 7  
   maintenance ..... 58  
 Re-start ..... 24, 43, 59  
 Risk assessment ..... 6  
   air-blast cooler ..... 39  
   AIT safety margin ..... 35  
   alternative fuels ..... 15  
   area classification ..... 34  
   compressor inlet explosion ..... 14  
   control component calibration ..... 60  
   control system failure ..... 41  
   dilution ventilation criterion ..... 36  
   electrical power failure  
     consequences ..... 45  
   emergency stop functions ..... 43  
   enclosure in zone 2 ..... 52  
   fire  
     detection ..... 30  
     detector selection ..... 30  
     extinguishing ..... 29  
   fuel pipe location ..... 19, 22  
   fuel pipe testing ..... 16, 60  
   fuel purging ..... 23  
   gas detector settings ..... 40  
   gas fuel  
     additional control ..... 16  
     failed start ..... 24  
     shut-off at trip ..... 19, 22  
     shut-off location ..... 19  
     valve proving ..... 20  
     vent valve monitoring ..... 20  
   ignition safety time ..... 24  
   liquid fuel  
     additional control ..... 20  
     drain valve position monitoring ..... 23  
     drain valves ..... 24

pressurization .....	22
shut-off location .....	22
valve proving .....	23
mist detection.....	27
modifications.....	7
over-speed protection.....	42
over-speed settings .....	42
permit to work .....	57
post-shutdown lubrication .....	29
replacement parts .....	7
residual ignition risk .....	27, 38
residual risks.....	54
retention of records.....	53
rotor and disc failure .....	11
start-up without purge .....	26
tolerable level of risk.....	7
trend monitoring.....	61
turbine hall, hot surfaces in zoned area .....	53
utility supplies .....	52
ventilation inlet location.....	38
ventilation outlet location .....	39
ventilation reverse flow .....	38
ventilation shutdown period .....	39
Rotating parts	
speed control .....	42
testing .....	10
Rotating parts failure	
overhanging rotor parts.....	11
rotor and disc failure .....	11
Rotor bearings .....	11
Rotor failure .....	11

**S**

Safety device	
definition .....	5
Safety instructions	
information for use .....	56
Safety related system	
control function .....	6
definition .....	5
Safety-related system	
control function .....	41
SAGBO .....	10
Scope .....	1
Semi-closed cycle.....	See Scope
Significant hazards	
list .....	See Annex A
Snow.....	10
Special heat source applications ..	See Scope
Speed control .....	42
Spill valve .....	22, 49
definition .....	5
Stability and handling.....	9
Starting systems .....	12
commissioning .....	13
motor casing .....	13
Stored energy	
access .....	59
accumulators .....	49

electrical .....	43
gas fuel system .....	19
Stray electrical current.....	44
Stress accelerated grain boundary	
oxidation .....	10
Stress corrosion cracking .....	10
Surge.....	9, 13, 15, 37, 57

**T**

Thermal relief	
fire extinguishant .....	33
pressure equipment.....	50
Titanium .....	10
Tolerable risk	
definition .....	5
Toxic emissions.....	46
Training .....	62
Turbine hall .....	53
access .....	53
area classification.....	53
fire extinguishant .....	34
fire protection.....	53
gas detection .....	53
ventilation .....	53

**U**

Ultra-violet resistance	
non-metallic pipework.....	51
Utility supplies	
pressure equipment.....	52

**V**

Vent	
definition .....	5
Ventilation .....	37
area classification.....	38
cooling .....	37
flow monitoring .....	39
heating .....	37
hot surfaces.....	38
inlet ducting .....	38
inlet filtration .....	38
inlet location .....	38, 52
screening tool .....	40
turbine hall.....	53
Vents .....	45
flammable gases .....	46
toxic emissions .....	46
Vibration .....	9
rotor parts .....	11

**W**

Warning signs and notices .....	61
Waste disposal	
compressor air inlet .....	15
Water systems	
pressure equipment.....	51
Water-mist fire extinguisher.....	30, 31
Wind .....	10

Copyright International Organization for Standardization  
Provided by IHS under license with ISO  
No reproduction or networking permitted without license from IHS

---

---

**ICS 27.040**

Price based on 82 pages