**Corrosion of metals and alloys — Test
method for isothermal-exposure oxidation
testing under high-temperature corrosion
conditions for metallic materials**

*Corrosion des métaux et alliages — Méthode d'essai pour les essais
d'oxydation en exposition isotherme des matériaux métalliques dans
des environnements corrosifs à haute température*





COPYRIGHT PROTECTED DOCUMENT

© ISO 2012

All rights reserved. Unless otherwise specified, no part of this publication may be reproduced or utilized in any form or by any means, electronic or mechanical, including photocopying and microfilm, without permission in writing from either ISO at the address below or ISO's member body in the country of the requester.

ISO copyright office
Case postale 56 • CH-1211 Geneva 20
Tel. + 41 22 749 01 11
Fax + 41 22 749 09 47
E-mail copyright@iso.org
Web www.iso.org

Published in Switzerland

Contents

Page

Foreword	iv
1 Scope	1
2 Normative references	1
3 Terms and definitions	2
4 Test method	2
4.1 Principle	2
4.2 Reagents and materials	2
4.3 Test apparatus	4
4.4 Procedure	5
4.5 Determination of mass change	8
4.6 Analysis of mass change	11
4.7 Post-test evaluation of test pieces	12
5 Report	12
5.1 Matters to be described	12
5.2 Supplementary note	13
Bibliography	14

Foreword

ISO (the International Organization for Standardization) is a worldwide federation of national standards bodies (ISO member bodies). The work of preparing International Standards is normally carried out through ISO technical committees. Each member body interested in a subject for which a technical committee has been established has the right to be represented on that committee. International organizations, governmental and non-governmental, in liaison with ISO, also take part in the work. ISO collaborates closely with the International Electrotechnical Commission (IEC) on all matters of electrotechnical standardization.

International Standards are drafted in accordance with the rules given in the ISO/IEC Directives, Part 2.

The main task of technical committees is to prepare International Standards. Draft International Standards adopted by the technical committees are circulated to the member bodies for voting. Publication as an International Standard requires approval by at least 75 % of the member bodies casting a vote.

Attention is drawn to the possibility that some of the elements of this document may be the subject of patent rights. ISO shall not be held responsible for identifying any or all such patent rights.

ISO 21608 was prepared by Technical Committee ISO/TC 156, *Corrosion of metals and alloys*.

Corrosion of metals and alloys — Test method for isothermal-exposure oxidation testing under high-temperature corrosion conditions for metallic materials

1 Scope

This International Standard specifies the method for continuous (single post-exposure mass measurement on each of a series of specimens without intermediate cooling) and discontinuous (series of mass measurements on a single specimen with intermediate cooling at predetermined times not necessarily regular, and relatively few in number) isothermal-exposure testing under high-temperature corrosion conditions of metallic materials in gaseous environments. In contrast, thermal-cycling oxidation testing (series of mass measurements on a single specimen with frequent regular cooling in order to accelerate high-temperature corrosion) is not included in this International Standard.

2 Normative references

The following referenced documents are indispensable for the application of this document. For dated references, only the edition cited applies. For undated references, the latest edition of the referenced document (including any amendments) applies.

ISO 3611, *Geometrical product specifications (GPS) — Dimensional measuring equipment: Micrometers for external measurements — Design and metrological characteristics*

ISO 6344-3:1998, *Coated abrasives — Grain size analysis — Part 3: Determination of grain size distribution of microgrits P240 to P2500*

ISO 13385-1, *Geometrical product specifications (GPS) — Dimensional measuring equipment — Part 1: Callipers; Design and metrological characteristics*

ISO 26146, *Corrosion of metals and alloys — Method for metallographic examination of samples after exposure to high-temperature corrosive environments*

ANSI B74.12-09, *Specifications for the Size of Abrasive Grain — Grinding Wheels, Polishing and General Industrial Uses*

ASTM E3-11, *Standard Guide for Preparation of Metallographic Specimens*

ASTM E220-07a, *Standard Test Method for Calibration of Thermocouples By Comparison Techniques*

ASTM E230/E230M-11e1, *Standard Specification and Temperature-Electromotive Force (emf) Tables for Standardized Thermocouples*

ASTM E407-07e1, *Standard Practice for Microetching Metals and Alloys*

ASTM E633-00, *Standard Guide for Use of Thermocouples in Creep and Stress-Rupture Testing to 1 800°F (1 000 °C) in Air*

ASTM E1350-07, *Standard Guide for Testing Sheathed Thermocouples, Thermocouples Assemblies, and Connecting Wires Prior to, and After Installation or Service*

FEPA 43-1984 R:1993, *Grit Sizes for Coated Abrasives*

JIS R6001-98, *Bonded abrasive grain sizes*

3 Terms and definitions

For the purposes of this document, the following terms and definitions apply.

3.1 scale
surface film and corrosion products produced on the surface of the test piece by high-temperature corrosion

3.2 adherent scale
scale adhering to the test piece after cooling

3.3 spalled scale
scale flaked from the test piece

3.4 gross mass change
mass change of test piece after cooling including collected spall

3.5 net mass change
mass change of test piece after cooling without spall

3.6 high-temperature corrosion
corrosion occurring when the temperature is higher than the dew-point of aqueous phases of the environment but at least 100 °C

3.7 breakaway
rapid increase in corrosion rate following a change from protective to non-protective scale growth

4 Test method

4.1 Principle

Several test pieces exposed for different times are necessary to define oxidation kinetics of the material. It is recommended that duplicate test pieces are used for each time. Data should be measured after at least four times with time intervals that increase progressively (e.g. 10 h, 30 h, 100 h, 300 h, 1 000 h).

4.2 Reagents and materials

4.2.1 Test pieces

The test pieces shall have the form of a rectangular plate, a disc or a cylinder with a minimum surface area of 300 mm² and a minimum thickness of 1,5 mm.

If the test pieces cannot be made according to these specifications, the shape and dimensions of the test piece shall be in accordance with the agreement between the parties involved.

The test pieces shall be finished by machining so that the strata affected by cutting do not remain.

The final finishing of the surface of the test pieces shall be performed with abrasives with a mean particle diameter of approximately 15 µm. This can be achieved by the use of abrasives according to Table 1.

If another surface finish is required by the parties involved, the surface finish condition shall be described.

Table 1 — Designation and mean diameter of particles of coated abrasives according to regional standards

Standard	Designation	Mean diameter μm	Region
FEPA ^a 43-1984 R:1993 ISO 6344-3:1998	P1200	15,3 ± 1,0	Europe
JIS R6001-87	#1000	15,5 ± 1,0	Japan
ANSI B74.12-01	600	16,0	America
^a Federation of European Producers of Abrasives.			

Sharp edges of test pieces may give anomalous behaviour. These shall be slightly rounded during the final stages of test piece preparation.

The surface of the test pieces shall not be deformed by marking, stamping or notching. Identification of the test pieces shall be solely on the basis of recording the relative position within the test chamber, however holes for test piece support (Figure 4) and or reference marking are permissible.

Where holes are used for test piece support, they shall be drilled prior to final finishing or application of coatings. These have to be taken into account when calculating the surface area.

The dimensions of the test pieces shall be measured prior to exposure at a minimum of three positions for each dimension with a precision of $\pm 0,02$ mm by means of the measuring instruments specified in ISO 3611 and ISO 13385-1.

The test pieces shall be dried after degreasing by ultrasonic cleaning using iso-propanol or ethanol.

If it is suspected that specimens may adsorb significant amounts of atmospheric contaminants such as water, it is recommended that the cleaned test pieces be stored in a desiccator prior to weighing and exposure.

The mass of the test pieces shall be determined prior to exposure. At least two measurements shall be made for each test piece. The difference between the measurements shall not exceed 0,05 mg.

It is recommended that duplicate test pieces be used for each time.

4.2.2 Gas supply

The gas supply system shall be capable of supplying the test gases at a constant rate to the test piece chamber.

When a humidifying regulator is used, it shall be capable of adjusting to the desired humidity. Deionized water of a conductivity less than $1 \mu\text{S cm}^{-1}$ shall be used, unless otherwise specified.

The space between the humidifying regulator and the test piece chamber shall be kept above the dew-point in order to avoid condensation.

The gas flow shall be monitored by a gas flow meter. The flow meter shall be located as close as practicable to the inlet of the test piece chamber, except where a humidifying regulator is used, in which case it shall be located upstream of the humidifier.

For testing in air, a specific humidity (mass fraction of water in air) of ~ 20 g/kg is recommended. This corresponds to a relative humidity of 100 % at 25 °C (dew-point) and is easy to obtain by bubbling through a water bath at 25 °C.

If any other humidity is employed, it shall be agreed between the parties concerned.

In the case that the gas is humidified, the water vapour content shall be measured. This can be achieved by, for example, the use of a hygrometer before the test piece chamber or by measuring the amount of water after condensation of the exhaust gases or by measuring the water consumption of the humidifier over the course of the experiment.

4.3 Test apparatus

4.3.1 Design of apparatus

The apparatus shall be composed, as a whole, of the temperature-regulating device for heating the test piece uniformly at a constant temperature. Ideally, the heating device should be equipped with a test portion capable of separating the test piece from outside air (this assembly is referred to as a closed system) unless this is impracticable for the tests planned. When applicable, a humidifying regulator should be used to continuously supply the gas kept at a constant humidity which should be monitored with a hygrometer. The gas supply shall be controlled by a gas flow meter.

An example of a basic design of a closed, horizontal, apparatus is shown in Figure 1. Other designs may use a vertical orientation.

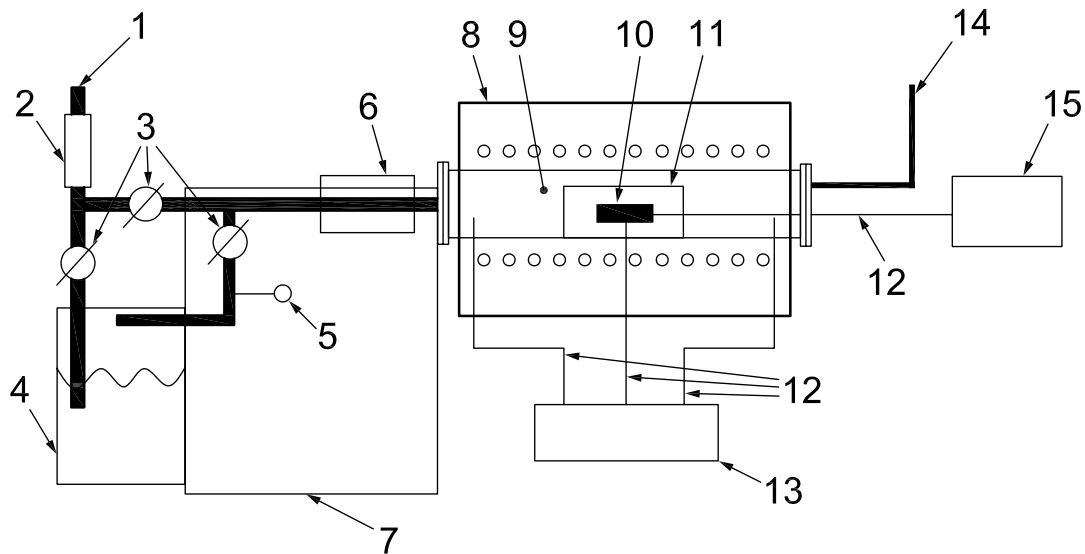

Key

- 1 gas supply
- 2 gas flow meter
- 3 valves
- 4 humidifying regulator
- 5 hygrometer
- 6 heating device containing catalyst for non-equilibrium gas mixtures
- 7 heating zone with ribbon heater
- 8 heating device
- 9 test piece chamber
- 10 test piece
- 11 test piece support
- 12 thermocouples
- 13 power/temperature control device
- 14 gas exhaust
- 15 measuring instrument

Figure 1 — Basic design of a closed apparatus

The heating device shall be constructed such that the test piece chamber is isolated from the external environment. It shall be ensured that a continuous gas flow within the prescribed range passes over the test pieces.

The test piece chamber shall not be composed of a material that reacts with the test atmosphere during the test to a degree that it changes the composition of the atmosphere.

If a closed system with a test piece chamber cannot be used, then the tests may be performed in an open system with laboratory air. In this case, the humidity of the air shall be recorded and the laboratories should be kept free from temperature changes and influences from weather conditions as far as possible. Ideally, however, closed systems should be used.

The furnace shall be characterized at the exposure temperature prior to the testing to determine the length of the isothermal zone inside the furnace. A common method is by the use of an independent moveable thermocouple.

The temperature-regulating device shall be capable of guaranteeing that the temperature of the test piece is kept within the permissible range given in Table 2.

The heating-device thermocouples for temperature control shall be as follows: The material for the thermocouple shall fully withstand the test temperature. Moreover, the diameter of wire is recommended to be as small as possible, within the limit where the thermoelectric power does not change in service.

4.3.2 Temperature monitoring

The temperature shall be measured by a suitable device, which is separate from the thermocouple used for control (see heating-device thermocouple described in 4.3.1), according to ASTM E633-00. Thermocouples of type K (Ni/Cr - NiAl) up to 800 °C, type S (10 %Rh/Pt - Pt) and type R (Pt/13 %Rh - Pt) up to 1 100 °C or type B (Pt/30 %Rh - Pt/6 %Rh) above 1 100 °C are preferred. A thermocouple should be positioned close to the test piece surface and must be calibrated according to the following paragraph. If however the environment does not allow the use of such thermocouples in this way, the test piece temperature has to be deduced from the furnace calibration using dummy test pieces and appropriate thermometry in an inert environment.

The calibration of thermocouples shall be performed in accordance with ASTM E220-07a, ASTM E230/E230M-11e1, or ASTM E1350-07. A representative thermocouple taken from the batch of wire may be calibrated.

It is recommended that thermocouples be recalibrated annually or at the beginning and the end of each experiment if there is uncertainty about thermocouple stability.

The thermocouple shall be capable of confirming the temperature of the test piece to be within the range given in Table 2. It has to be on a defined, fixed place as close to the test pieces as possible.

Thermocouple sheaths shall be used to protect the thermocouple wires. The thermocouple sheaths shall fully withstand the test temperature and environment.

Table 2 — Permissible tolerance of temperature of test pieces

Temperature range, °C	≤300	300 to 600	600 to 800	800 to 1000	1000 to 1200	>1200
Temperature tolerance, °C	±2	±3	±4	±5	±7	By agreement

4.4 Procedure

4.4.1 Support of test pieces

The test pieces shall be supported according to the following principles.

The test piece shall be supported by a material that does not react at the test temperature. Contact between the test piece and support shall be minimized.

The support of the test piece to be used shall be designed to be able to collect the scale even if it flakes during testing or during cooling after finishing the test.

When testing multiple test pieces simultaneously, each test piece shall be inserted into an individual test piece support in order to enable the collection of all scale, including the scale spalled from each test piece.

The support design shall ensure that no major faces of the test pieces are shielded from the test atmosphere.

Examples of suitable test piece supports and the basic layout of test piece arrangement are shown in Figures 2 to 4.

Where possible depletion of active species in the test atmosphere is a concern, exchange of test atmosphere can be improved by the use of holes or slots in the bottom area of the side walls of the test piece support.

When only net mass-change data are required, multiple test pieces may be inserted in a single test piece support.

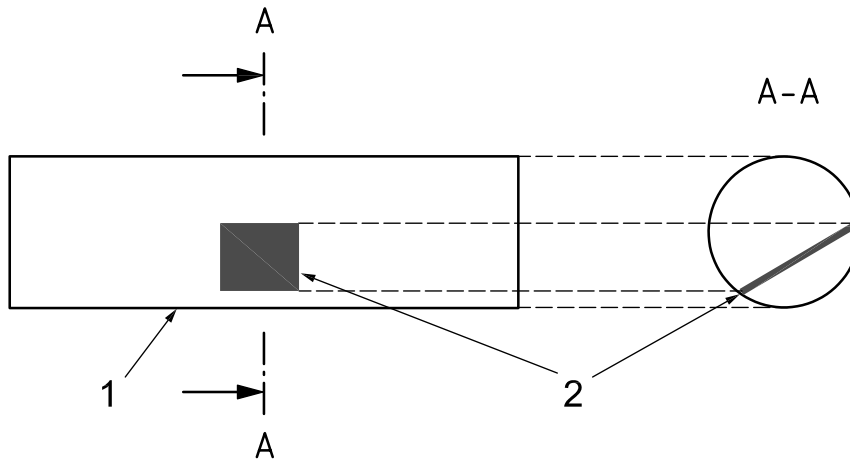

Key

- 1 high-purity alumina tube for supporting test piece
- 2 test piece

**Figure 2 — Test piece support and basic layout of test piece arrangement — Tube design
(this type of support is not suitable for rapid heating and cooling)**

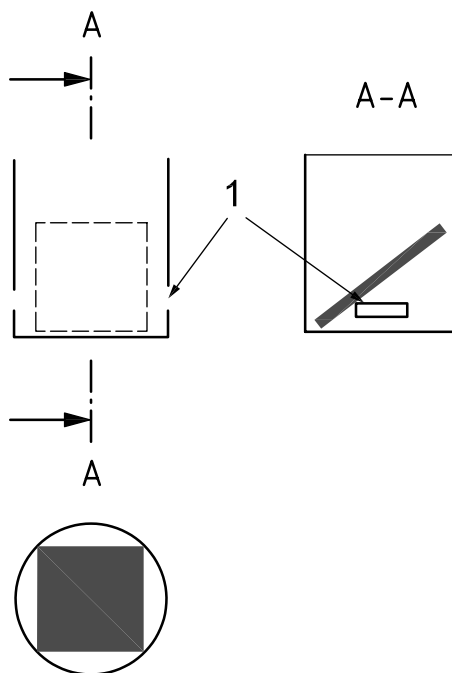

Key

- 1 holes

Figure 3 — Test piece support and basic layout of test piece arrangement — Round crucible

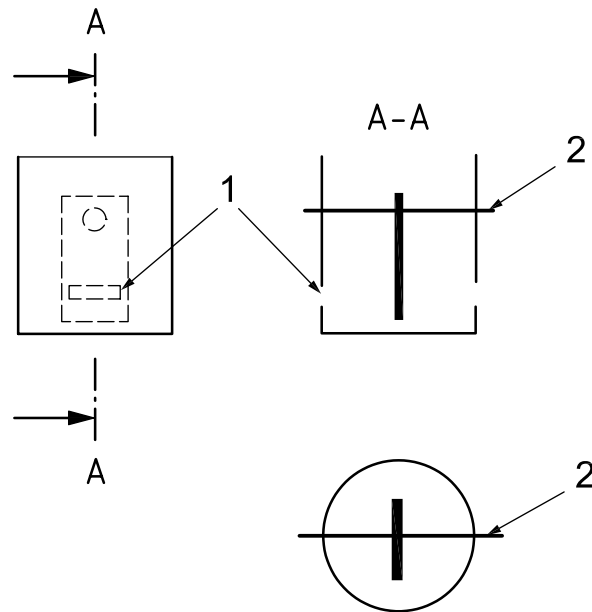

Key

- 1 holes
- 2 alumina rod

Figure 4 — Test piece support and basic layout of test piece arrangement — Rod-supported design

4.4.2 Test environment

The gas flow shall be high enough to ensure that no significant depletion of reaction species will occur. At the same time, the gas flow shall be slow enough to allow the gas mixture to preheat and in some applications to reach equilibrium. The flow rate of the test gas shall be sufficient to ensure complete replacement of the test gas within the test chamber at least three times an hour.

For testing in air in closed systems, the humidity should be controlled as specified in 4.2.2.

For testing in air in open systems, it should be noted that the humidity of laboratory air varies significantly depending on the location of the laboratory and local weather conditions. It must be recognized that these variations may affect test results significantly. In this case, the humidity of the laboratory air shall be recorded during the test.

For testing in other environments, the humidity should be specified and measured.

4.4.3 Heating method

The heating method shall be as follows.

The test piece on its support shall be placed in the furnace either at room temperature or at the test temperature, by agreement between the parties. In the former case, the time to reach the test temperature shall be recorded.

Where test pieces are loaded into a cold furnace, heating shall be carried out in the test gas. In the case of humidified atmospheres, the humidification shall not be started until the temperature in the coldest part of the test chamber exceeds 100 °C.

Where test pieces are loaded into a hot furnace, a flow of inert gas may be used during the loading procedure.

The heating shall be carried out in a manner such that the temperature of test pieces does not exceed the upper limit of the permissible range listed in Table 2.

For discontinuous exposure, the same heating method shall be applied each time the test pieces are reloaded for continued exposure.

4.4.4 Test duration

The test is defined to commence when the test piece temperature exceeds 97 % of the desired test temperature T_{dwell} (measured in kelvins).

The test ends when the temperature of the test piece falls below 97 % of the desired test temperature T_{dwell} (measured in kelvins).

The test duration shall be relevant to the intended application and agreed between the parties concerned. The materials' behaviour observed in short-term exposures may not continue at long durations; therefore, for testing of relevance to long-term service conditions, the longest exposure time is recommended to be at least 300 h.

4.4.5 Cooling of test pieces

The test piece on its support shall be removed from the furnace either at the test temperature or after cooling to below 100 °C, by agreement between the parties. In the latter case, the time to cool to 100 °C shall be recorded.

Where test pieces are cooled inside the furnace, cooling shall be carried out in the test gas. In the case of humidified atmospheres, the humidification shall be stopped before the temperature in the coldest part of the test chamber falls below 200 °C.

Where test pieces are removed from the hot furnace, a flow of inert gas may be used during the unloading procedure.

4.5 Determination of mass change

4.5.1 Principle

In order to define oxidation kinetics, determination of the mass change has to be performed. It is recommended to use duplicate test pieces for each material. When handling specimens, the use of tweezers is recommended. Test pieces shall never be touched with the hands to eliminate any contamination (grease, salts). Care has to be taken when using gloves, as contamination with the separating agent of the gloves leads to falsification in mass determination. If repeated measurements are not consistent, the temperature and humidity of the weighing environment has to be controlled.

4.5.2 Measurements prior to testing

New test piece supports shall be baked in air to remove volatile compounds from production. The recommended baking conditions are at least 24 h at a temperature of 1 000 °C. If water adsorption is suspected to have occurred, used test piece supports shall be dried at significantly above 100 °C.

The mass of the test pieces shall be determined prior to exposure [$m_{\text{T}}(t_0)$, Figure 5]. At least two individual measurements shall be made for each test piece with a precision of 0,02 mg. The maximum difference between the measurements shall not exceed $\pm 0,05$ mg.

The mass of the test piece supports shall be determined prior to exposure [$m_{\text{S}}(t_0)$; Figure 5]. At least two individual measurements shall be made for each test piece support. Where the test piece support has a mass of less than 20 g, the precision shall be 0,02 mg. The maximum difference between the measurements shall not exceed $\pm 0,05$ mg. For test piece supports of higher mass the precision shall be 0,1 mg. The maximum difference between the measurements shall not exceed $\pm 0,3$ mg in this case.

When only net mass-change data are required, mass determination of the test piece support is not required.

4.5.3 Intermediate mass-change determination (only for discontinuous isothermal testing) and final mass-change determination

After removing it from the furnace, the test piece support containing the test pieces shall be settled in the weighing room for 15 min to allow them to acclimatize. The test pieces shall not be descaled. However, loosely adherent oxide scale shall be removed by gently tapping the test piece on the inside of the test piece support to ensure that the spalled scale is collected. All spalled scale shall be retained in the test piece support upon re-insertion into the furnace for continued exposure.

In the case that hygroscopic corrosion products have been formed, test pieces should be weighed as soon as possible or shall be stored in a desiccator after removal from the furnace until immediately before weighing.

If significant formation of volatile species occurs, this will interfere with mass determination. An indication for formation of volatile species is deposition of liquid or solid products at the cooler parts of the furnace.

For each mass-change determination at intermediate stages and the final stage, the mass of the test piece support containing one test piece and spalled scale, the test piece support including spalled scale and the mass of the test piece including adherent scale shall be determined as shown in Figure 7. Three individual measurements shall be made for each test piece support containing one test piece, each test piece support and each test piece with a precision of 0,02 mg for each measurement. The standard deviation for each set of measurements shall not exceed 0,05 mg.

Care must be taken during mass measurements to avoid spallation of oxide scale caused by mechanical contacts with tweezers, etc. A test piece support with a rod support design as shown in Figure 4 circumvents the problem and allows the determination of mass changes without direct contact of the tweezers with the test piece as shown in Figures 6 and 7.

Gross mass change Δm_g as defined in 3.4 is determined according to Equation (1).

$$\Delta m_g(t_n) = m_{ST}(t_n) - m_{ST}(t_0) \quad (1)$$

where

$\Delta m_g(t_n)$ is the gross mass change at time t_n (mg);

$m_{ST}(t_n)$ is the mass of test piece support and test piece at time t_n (mg);

$m_{ST}(t_0)$ is the mass of test piece support and test piece prior to the test (mg).

The mass of spalled oxide Δm_{sm} is determined according to Equation (2).

$$\Delta m_{sm}(t_n) = m_S(t_n) - m_S(t_0) \quad (2)$$

where

$\Delta m_{sm}(t_n)$ is the mass change of spalled material at time t_n (mg);

$m_S(t_n)$ is the mass of test piece support at time t_n (mg);

$m_S(t_0)$ is the mass of test piece support prior to the test (mg).

Net mass change Δm_n as defined in 3.5 is determined according to Equation (3):

$$\Delta m_n(t_n) = m_T(t_n) - m_T(t_0) \quad (3)$$

where

$\Delta m_n(t_n)$ is the net mass change at time t_n (mg);

$m_T(t_n)$ is the mass of test piece at time t_n (mg);

$m_T(t_0)$ is the mass of test piece prior to the test (mg).

or when a rod-supported design as shown in Figure 6 is used, by Equation (4):

$$\Delta m_n(t_n) = \Delta m_g(t_n) - \Delta m_{sm}(t_n) \quad (4)$$

where

$\Delta m_n(t_n)$ is the net mass change at time t_n (mg);

$\Delta m_g(t_n)$ is the gross mass change at time t_n (mg);

$\Delta m_{sm}(t_n)$ is the mass change of spalled material at time t_n (mg).

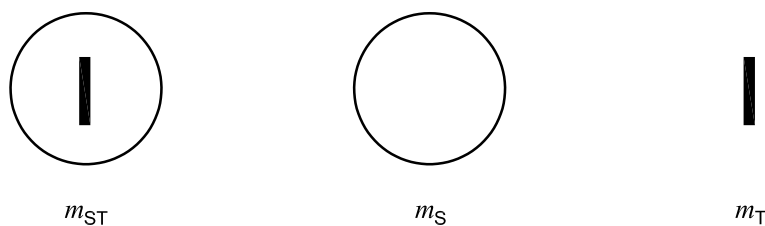

Key

m_{ST} mass of test piece support with test piece

m_S mass of test piece support

m_T mass of test piece

Figure 5 — Mass determination — Variant I

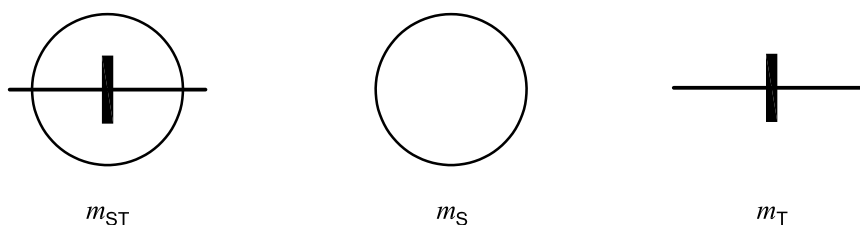

Key

m_{ST} mass of test piece support with test piece held by alumina rod

m_S mass of test piece support

m_T mass of test piece with rod

NOTE The test piece can be removed by holding the rod with tweezers.

Figure 6 — Mass determination — Variant II

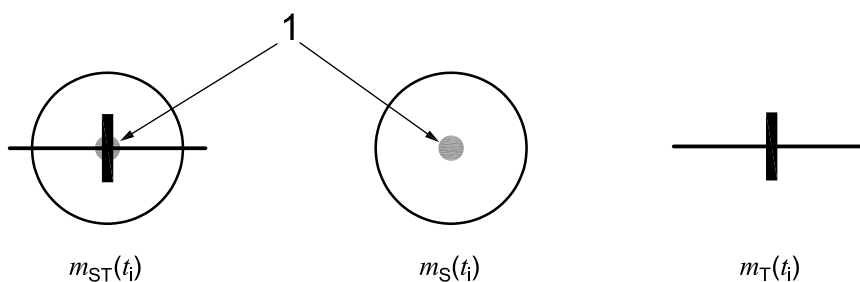

Key

1 spalled oxide

$m_{ST}(t_i)$ mass of test piece support with test piece held by e.g. alumina rod at t_i

$m_S(t_i)$ mass of test piece support including spall at t_i

$m_T(t_i)$ mass of test piece with rod at t_i

**Figure 7 — Mass determination variant II
(in which spallation has occurred)**

4.5.4 Frequency of mass-change determination (only applicable to discontinuous isothermal testing)

Data should be measured after at least four times with time intervals that increase progressively, e.g. (10 h, 30 h, 100 h, 300 h, 1 000 h...).

It is recommended to record images of the macroscopic appearance of the test piece after each time interval.

4.6 Analysis of mass change

Gross and net mass change shall be plotted versus time on a linear axes. For a more detailed analysis of mass change, it is recommended to follow the instructions given in the following paragraphs.

Net mass change of test pieces shall be plotted versus time on a double logarithmic plot as shown in Figure 8. According to common use in high-temperature oxidation testing, the mass change is usually described mathematically by Equation (3) or Equation (4). The values for the oxidation rate k and the exponent of the growth law n shall be reported. Any deviation from protective behaviour shall be noted.

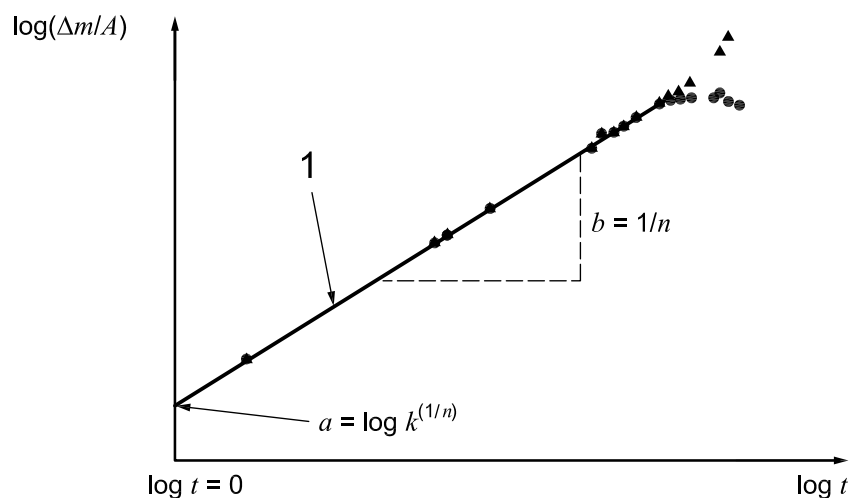

Figure 8 — Double logarithmic plot of net mass change vs. time

The double logarithmic plot (log net mass change vs. log time) may reveal a change in the mechanism of oxidation behaviour (spallation, break-away oxidation) by a change of the slope. As long as protective oxide growth takes place, it can be described mathematically by Equation (5).

$$\left(\frac{\Delta m_n}{A}\right)^n = kt \rightarrow \frac{\Delta m_n}{A} = k^{\frac{1}{n}} t^{\frac{1}{n}} \rightarrow \log\left(\frac{\Delta m_n}{A}\right) = \log\left(k^{\frac{1}{n}} t^{\frac{1}{n}}\right) = \log k^{\frac{1}{n}} + \frac{1}{n} \log t \quad (5)$$

A change in the mechanism (spallation, break-away oxidation) becomes apparent by a change of the slope in the double logarithmic plot. The point at which this occurs can normally be identified by visual inspection and determines the end of the linear part of the curve.

The parameter n can be calculated from the slope $b = 1/n$ of the linear part of the curve.

From the y-axis intercept a (at $\log t = 0$), the oxidation rate constant k for the linear region shall be calculated as given in Equation (6).

$$a = \log k^{\frac{1}{n}} \rightarrow a = \frac{1}{n} \log k \rightarrow k = 10^{a \cdot n} \quad (6)$$

k shall usually be expressed in units of $\left[\frac{\text{mg}}{\text{cm}^2}\right]^n \cdot \text{h}^{-1}$. The special case $n = 2$ corresponds to the commonly used designation of a parabolic growth law.

The parameters k and n are both essential descriptors and shall always be quoted together. Ranking in terms of only one of these parameters is not appropriate. Both parameters must be used to evaluate, interpolate or extrapolate mass-change data. If used for extrapolation, it is essential to ensure that no change in mechanism will occur during the extrapolated time period.

4.7 Post-test evaluation of test pieces

4.7.1 Macroscopic evaluation

The macroscopic appearance of the test piece surface shall be photographed.

4.7.2 Observation of surface and cross-section of test pieces

Metallographic examination should be made on the surface and cross-section. A detailed procedure for quantitative analysis is given in ISO 26146.

5 Report

5.1 Matters to be described

The following data, where known, shall be included in the report on the test results.

5.1.1 Test material

- a) Manufacturer.
- b) Name of material (Manufacturer's designation; ASTM, DIN, etc.).
- c) Grade or symbol.
- d) Heat number/Batch number.
- e) Chemical composition (analysis technique).
- f) Processing condition.
- g) Heat-treatment condition.
- h) Microstructure of the material determined according to ASTM E3-11 and etching according to ASTM E407-07e1.

5.1.2 Test piece

- a) Designation of test piece.
- b) Sampling conditions of the test piece from raw material (crystallographic orientation, rolling direction, etc.).
- c) Dimensions and surface area of test piece.
- d) Surface-finish condition of test piece.
- e) Degreasing method of test piece.
- f) Method of test piece support.
- g) Initial mass.

5.1.3 Testing environments

- a) Test temperature.

- b) Test duration.
- c) Chemical environment including humidity.
- d) Volume of test chamber.
- e) Volume flow rate of test gas.
- f) Open or closed system according to 4.3.1.
- g) If open systems are used, the humidity of the laboratory air.

5.1.4 Test results

- a) Plot of gross and net mass change per area in mg cm^{-2} vs. time, according to 4.6.
- b) Plot of the amount of spalled scale in mg cm^{-2} vs. time.
- c) In the case of a more detailed analysis, the values of the parameters k and n describing scale growth kinetics including the time range over which analysis was performed.
- d) Image of appearance after testing.
- e) Image of cross-section including the surface layer of the metallographic section of the test piece after testing. The chosen magnifications must clearly show the extent of the total attack in a single micrograph.
- f) Results of any metallographic investigations performed according to 4.7.

5.2 Supplementary note

It is additionally desirable to describe the following matters in the report on the test results.

- a) Mechanical properties of the initial material.
- b) Microstructure of the initial material and sampling conditions.
- c) Details of the test apparatus.

Bibliography

- [1] ISO 8044, *Corrosion of metals and alloys — Terms and basic definitions*
- [2] ASTM G54-84, *Standard Practice for Simple Static Oxidation Testing* (withdrawn in 2002, no replacement)
- [3] JIS Z 2281:1993, *Test method for continuous oxidation test at elevated temperatures for metallic materials*

ICS 77.060

Price based on 14 pages