**Vacuum technology — Standard
methods for measuring vacuum-pump
performance —**

**Part 1:
General description**

*Technique du vide — Méthodes normalisées pour mesurer les
performances des pompes à vide —*

Partie 1: Description générale





COPYRIGHT PROTECTED DOCUMENT

© ISO 2012

All rights reserved. Unless otherwise specified, no part of this publication may be reproduced or utilized in any form or by any means, electronic or mechanical, including photocopying and microfilm, without permission in writing from either ISO at the address below or ISO's member body in the country of the requester.

ISO copyright office
Case postale 56 • CH-1211 Geneva 20
Tel. + 41 22 749 01 11
Fax + 41 22 749 09 47
E-mail copyright@iso.org
Web www.iso.org

Published in Switzerland

Contents

Page

Foreword	iv
Introduction	v
1 Scope	1
2 Normative references	1
3 Terms and definitions	1
4 Symbols and abbreviated terms	3
5 Test methods	4
5.1 Volume flow rate (pumping speed) measurement by the throughput method	4
5.2 Volume flow rate (pumping speed) measurement by the orifice method	8
5.3 Volume flow rate (pumping speed) measurement by the pump-down method	13
5.4 Measurement of the base pressure	17
5.5 Measurement of the compression ratio and the critical backing pressure	18
Annex A (informative) Mean free path of some important gases	22
Annex B (informative) Measuring uncertainties	23
Bibliography	26

Foreword

ISO (the International Organization for Standardization) is a worldwide federation of national standards bodies (ISO member bodies). The work of preparing International Standards is normally carried out through ISO technical committees. Each member body interested in a subject for which a technical committee has been established has the right to be represented on that committee. International organizations, governmental and non-governmental, in liaison with ISO, also take part in the work. ISO collaborates closely with the International Electrotechnical Commission (IEC) on all matters of electrotechnical standardization.

International Standards are drafted in accordance with the rules given in the ISO/IEC Directives, Part 2.

The main task of technical committees is to prepare International Standards. Draft International Standards adopted by the technical committees are circulated to the member bodies for voting. Publication as an International Standard requires approval by at least 75 % of the member bodies casting a vote.

Attention is drawn to the possibility that some of the elements of this document may be the subject of patent rights. ISO shall not be held responsible for identifying any or all such patent rights.

ISO 21360-1 was prepared by Technical Committee ISO/TC 112, *Vacuum technology*.

This first edition of ISO 21360-1 cancels and replaces ISO 21360:2007, of which it constitutes a minor revision.

ISO 21360 consists of the following parts, under the general title *Vacuum technology — Standard methods for measuring vacuum-pump performance*:

- *Part 1: General description*
- *Part 2: Positive displacement vacuum pumps*

.....

Introduction

This part of ISO 21360 is a basic standard for measuring the performance data of vacuum pumps. The methods specified here are well known from existing national and International Standards. In developing this part of ISO 21360, the aim has been to provide a single document containing the measurements of performance data of vacuum pumps and to simplify the future development of specific vacuum pump standards.

Specific vacuum pump standards will contain a suitable selection of measurement methods from this part of ISO 21360 in order to determine the performance data, limiting values and specific operational conditions on the basis of the specific properties of the particular kind of pump. Whenever a discrepancy exists between this part of ISO 21360 and the specific standard, it is the specific standard which is valid.

.....

Vacuum technology — Standard methods for measuring vacuum-pump performance —

Part 1: General description

1 Scope

This part of ISO 21360 specifies three methods for measuring the volume flow rate and one method each for measuring the base pressure, the compression ratio, and the critical backing pressure of a vacuum pump.

The first method for measuring the volume flow rate (the throughput method) is the basic concept, in which a steady gas flow is injected into the pump while the inlet pressure is measured. In practice, the measurement of gas throughput may be complicated or inexact. For this reason, two other methods are specified which avoid the direct measurement of throughput.

The second method for measuring the volume flow rate (the orifice method) is used when there is very small throughput at very small inlet pressures (under a high or ultra-high vacuum). It is based on measuring the ratio of pressures in a two-chamber test dome in which the two chambers are separated by a wall with a circular orifice.

The third method for measuring the volume flow rate (the pump-down method) is well suited for automated measurement. It is based on the evacuation of a large vessel. The volume flow rate is calculated from two pressures, before and after a pumping interval, and from the volume of the test dome. Different effects, such as leak and desorption rates, gas cooling by nearly isentropic expansion during the pumping interval, and increasing flow resistance in the connection line between test dome and pump caused by molecular flow at low pressures, influence the results of the pressure measurement and the resulting volume flow rate.

The choice of the required measurement methods depends on the properties of the specific kinds of vacuum pump, e.g. the measurement of the critical backing pressure is only necessary for vacuum pumps which need a backing pump. All data that are measured on a vacuum pump, but not specified in this part of ISO 21360 (e.g. measurement of power consumption), are defined in the specific pump standard.

2 Normative references

The following referenced documents are indispensable for the application of this document. For dated references, only the edition cited applies. For undated references, the latest edition of the referenced document (including any amendments) applies.

ISO 3529-2, *Vacuum technology — Vocabulary — Part 2: Vacuum pumps and related terms*

3 Terms and definitions

For the purposes of this document, the terms and definitions given in ISO 3529-2 and the following apply.

3.1 volume flow rate

$$q_V = \frac{dV}{dt}$$

where

V is volume;

t is time

[ISO 80000-4:2006^[4], 4-30]

EXAMPLE In the context of this part of ISO 21360, the volume flow rate is the volume of gas which, under ideal conditions, flows from the test dome through the pump inlet per time.

NOTE 1 For practical reasons, the volume flow rate of a given pump and for a given gas is conventionally considered to be equal to the quotient of the throughput of this gas and of the equilibrium pressure at a given location. The volume flow rate is expressed in cubic metres per hour or litres per second.

NOTE 2 The term “pumping speed” and symbol “ S ” are often used instead of “volume flow rate”.

3.2 inlet pressure

p_1, p_d, p_e
pressure at the inlet of the pump, measured at a defined location in the test dome

3.3 base pressure

p_b
pressure obtained in the test dome after conditioning the vacuum pump and the test dome

See 5.4.

NOTE The base pressure is the value which the pressure in the test dome approaches asymptotically. It is the lowest pressure obtainable with the pump, but there is no practical method of measurement or specification.

3.4 maximum working pressure

p_{1max}
highest pressure on the inlet side that the vacuum pump and the driving device can withstand for a prolonged period of operation time without being damaged

3.5 backing pressure

p_3
pressure at the outlet of a vacuum pump

3.6 critical backing pressure

p_c
maximum backing pressure for which the conditions are defined in the instruction manual or in a specific standard for the particular vacuum pump

3.7 compression ratio

K_0
ratio of the backing pressure, p_3 , to the inlet pressure, p_1 , of the vacuum pump without throughput, expressed by the equation:

$$K_0 = \frac{p_3}{p_1}$$

3.8**test dome**

special vacuum vessel with precisely defined size, diameter and connection flanges on specified locations, used for standard performance data measurements on vacuum pumps

3.9**throughput** Q

amount of gas flowing through a duct, expressed by the equation:

$$Q = \frac{p_1 V}{t} = p_1 q_V$$

where

p_1 is the (high) vacuum pressure on the inlet;

q_V is the volume flow rate of the test pump;

t is time;

V is the volume of the test dome

3.10**standard gas flow rate** q_{Vstd}

volume flow rate at standard reference conditions, i.e. 0 °C and 101 325 Pa

NOTE Standard reference conditions are defined in ISO 3529-1:1981^[1], 1.0.2.

4 Symbols and abbreviated terms

Symbol	Designation	Unit
a	inner diameter of the connection pipe between test pump and quick-acting valve (items 3 and 5 in Figure 6)	m
A	cross-section of the connection pipe between test pump and quick-acting valve (items 3 and 5 in Figure 6)	m ²
C	conductance	m ³ /s (= 10 ³ l/s)
d	diameter of orifice	m
D	inner diameter of test dome	m
D_N	nominal diameter of test dome	m
K_0	compression ratio of vacuum pump with zero throughput	—
l	length of the connection pipe between test pump and quick-acting valve (items 3 and 5 in Figure 6)	m
\bar{l}	mean free path	m
M	molar mass of gas	kg/mol
p_0	standard atmospheric pressure — 101 325 Pa (defined in ISO 3529-1:1981 ^[1] , 1.0.2)	Pa
p_1	(high) vacuum pressure on inlet	Pa (or mbar)

ISO 21360-1:2012(E)

p_{1max}	maximum working pressure on inlet	Pa (or mbar)
p_3	vacuum pressure in backing line	Pa (or mbar)
$p_{t_1}, p_{t_2}, p_{t_3}$	pressures in the test dome for the pump-down method, measured before and after time intervals $\Delta t_1, \Delta t_2, \Delta t_3$	Pa (or mbar)
p_{b1}, p_{b2}, p_{b3}	base pressures	Pa (or mbar)
p_c	critical backing pressure	Pa (or mbar)
p_d, p_e	pressures in the test dome for the orifice method	Pa (or mbar)
Q	gas throughput of vacuum pump	Pa•l/s (or mbar•l/s)
Q_r	test gas load	Pa•l/s (or mbar•l/s)
q_V	volume flow rate of test pump	l/s (or m ³ /h)
q_{VBP}	volume flow rate of backing pump	l/s (or m ³ /h)
q_{Vscm}	volume flow rate at standard reference conditions for gases, i.e. 0 °C and 101 325 Pa	sccm (or cm ³ /min)
q_{Vstd}	volume flow rate at standard reference conditions for gases, i.e. 0 °C and 101 325 Pa	l/s (or m ³ /h)
Q_{max}	maximum gas throughput of vacuum pump which the pump can withstand without damage	Pa•l/s (or mbar•l/s)
R	ideal gas constant	8,314 J/(mol•K)
T	thermodynamic temperature	K
T_0	273,15 K (defined as 0 °C in ISO 3529-1:1981 ^[1] , 1.0.2)	K
T_D	temperature of the test dome	K
T_f	temperature of the flow meter	K
u	measurement uncertainty	—
V	volume of the test dome	l, m ³
V_i	volume of connection pipe between test pump and quick-acting valve (items 3 and 5 in Figure 6)	l, m ³
δ	thickness of the orifice wall at the orifice diameter	m

5 Test methods

5.1 Volume flow rate (pumping speed) measurement by the throughput method

5.1.1 General

The throughput method is the one most used for vacuum pumps and is applicable to all pressure ranges and pump sizes where flow meters for gas throughput measurements are available with sufficient accuracy. The gas flow measuring ranges shall be chosen by multiplying the expected volume flow rate by the maximum and minimum working pressure of the test pump.

All measuring devices shall be calibrated either:

- a) in a traceable way to a vacuum primary or to a national standard, or
- b) by means of instruments of absolute measure which are traceable to the SI units and to which measurement uncertainties can be attributed.

In the case of calibrated measuring instruments, there should exist a calibration certificate in accordance with ISO/IEC 17025^[3].

5.1.2 Test dome for the throughput method

For these measurements, use a test dome as shown in Figure 1 with the same nominal diameter, D_N , as that of the pump inlet. The face of the dome opposite the inlet flange may be flat, conical or slightly curved, with the same average height above the flange as the flat face. Three flanges are preferable for pressure measurement at a height of $D/2$ above the bottom flange if more than one pressure gauge is used. The diameter of these flanges should be greater than or equal to the flanges of the gauges used, and their mounting dimensions shall be noted. No measuring port shall be located in the angle range $\pm 45^\circ$ next to a gas inlet port. The connection pipes between flange and dome shall not protrude beyond the dome wall on the inside, with the exception of the gas inlet pipe.

If necessary for the test pump, the test dome shall be fitted with a device for bake-out that ensures uniform heating of the dome to achieve the base pressure.

The volume of the test dome may depend on the pump type. Refer to the specific pump standard for details.

For pumps with an inlet flange diameter of less than $D_N = 100$ mm, the diameter of the dome shall correspond to $D_N = 100$ mm. The transition to the pump inlet flange shall be made through a 45° conical adaptor, as shown in Figure 1.

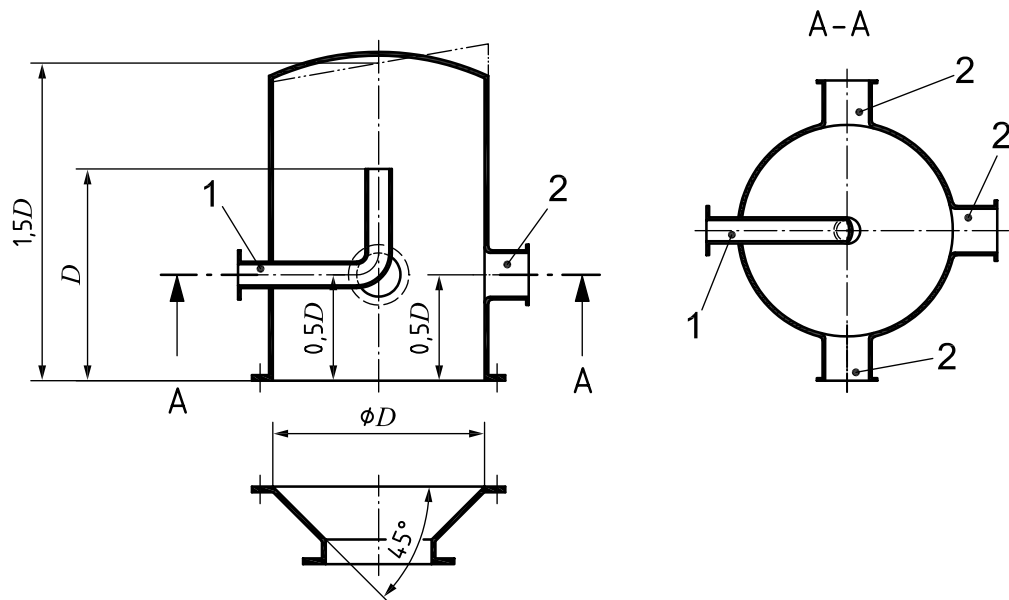

Key

- 1 gas inlet pipe and temperature measuring point for T_D
- 2 vacuum gauge and mass spectrometer connections
- D inner diameter of test dome, in metres

Figure 1 — Test dome for the throughput method

5.1.3 Experimental setup

See Figure 2.

The test dome shall be clean and dry. The cleanness of the pump, seals and other components shall be appropriate for the expected base pressure. All components are mounted together under clean conditions in accordance with Figure 2. Because of the narrow measuring range, flow meters with different ranges may be switched in series. If flow is restricted by a small flow meter, they may be used in parallel with a manifold, adding a valve between every flow meter and the manifold. Instead of the flow meter and the gas inlet valve, mass flow controllers with programmable throughputs may be used. They shall be combined in parallel on a manifold.

The leak-tightness of large mass flow controllers is not sufficient in many cases. In such cases, it is advisable that valves be used between the flow controller and the manifold.

Ionization gauges and mass spectrometers shall be installed in such a way that there is no direct geometrical path between them.

CAUTION — Observe the safety instructions of the vacuum pump manufacturer.

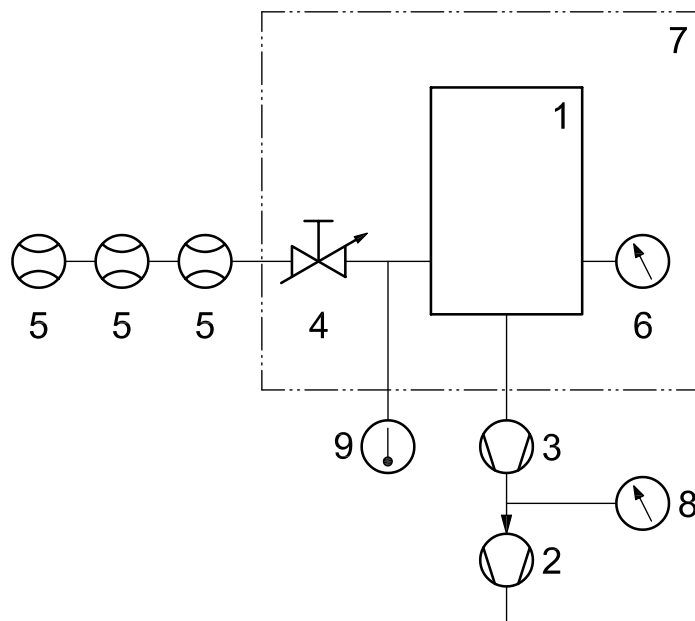

Key					
1	test dome	4	gas inlet valve	7	heating jacket (optional)
2	backing pump	5	flow meters to measure Q	8	vacuum gauge to measure p_3
3	test pump	6	vacuum gauge to measure p_1	9	temperature measuring point for T_D

NOTE Items 2 and 8 are only used in connection with high-vacuum test pumps.

Figure 2 — Arrangement for measuring volume flow rate (pumping speed) with throughput method

5.1.4 Determination of the volume flow rate

The method adopted for the measurement of the volume flow rate, q_V , is the throughput method for which the gas throughput, Q , is measured outside the dome. If the pressure, p_1 , in the test dome, measured by a vacuum

gauge at the specified height above the bottom flange (see Figure 1), is held constant, the volume flow rate, q_V , is obtained by the relationship

$$q_V = \frac{Q}{p_1 - p_b} \quad (1)$$

where p_b is the base pressure in the test dome (see 5.4).

An analogue equation is valid for the volume flow rate of the backing pump, q_{VBP} .

$$q_{VBP} = \frac{Q}{p_3 - p_{b3}} \quad (2)$$

The gas throughput can be measured volumetrically (gas burettes, gas counters) by means of viscous flow effects (rotameter, capillaries) or, in most cases, by means of thermoelectric mass flow meters (see Reference [6], pp. 109–113).

Because of the dependence of the temperature on the gas volume, for all volumetric measurements, corrections by a factor of T_D/T_f are necessary if the temperature, T_f , of the flow meter and T_D of the test dome are different.

NOTE Thermoelectric mass flow meters do not measure the throughput, but the volume flow rate, q_{Vstd} , at standard reference conditions for gases (i.e. $p_0 = 101\,325$ Pa and $T_0 = 273,15$ K, see ISO 3529-1:1981^[1], 1.0.2). To obtain the throughput, q_V is multiplied by the factor $T_D p_0 / T_0$. Consequently, q_V is given by:

$$q_V = \frac{q_{Vstd} p_0 T_D}{T_0 (p_1 - p_b)} \quad (3)$$

The unit “sccm” (standard cubic centimetre per minute) is frequently used for q_{Vstd} . If so, one obtains q_V , in litres per second, by inserting [$q_{Vstd} = (q_{Vsccm}/\text{sccm}) \times 10^{-3}$ l/60 s], [$p_0 = 101\,325$ Pa] and [$T_0 = 273,15$ K] in Equation (3), as follows:

$$q_V = \frac{(q_{Vsccm} / \text{cm}^3 \text{ min}^{-1}) \times 10^{-3} \text{ l} \times 101\,325 \text{ Pa} \times T_D}{60 \text{ s} \times 273,15 \text{ K} \times (p_1 - p_b)} \text{ l/s} \quad (4)$$

5.1.5 Measuring procedure

The arrangement of the measuring equipment with the test dome from Figure 1 is given in Figure 2. At the start, when the gas inlet valve is closed, the base pressure shall prevail in the test dome (see 5.4). Then gas is admitted to the test dome through the adjustable valve. Measurements are made with increasing pressure from a threshold value, allowing the correct use of the flow meter. During this period of time, the ambient temperature shall be constant within ± 2 °C.

When the required pressure, p_1 , is obtained, within a variation of 3 %/min, measure the pressures, p_1 and p_3 , the ambient temperature and the test dome temperature, T_D , as well as the admitted throughput, Q . If the throughput remains steady to within ± 3 %, the measurement at this point may be regarded as valid. If the throughput is unsteady due to a transient condition, wait until it stabilizes. If the throughput measurement lasts for more than 60 s, the pressure, p_1 , in the dome shall be noted at least every minute. In this case, the pressure is the average of the measured values. If during a measurement, the pressure or the throughput varies by more than ± 3 %, the measurement shall be repeated until the readings are stable.

Measurements shall be made at a minimum of three points per pressure decade of p_1 . If the throughput is increased to the maximum allowed value, Q_{max} , the maximum inlet pressure is obtained whose values may be limited by the manufacturer.

NOTE Volume flow rate measurements can be made with different gases. When the gas is changed, all pipes connected to the gas inlet valve are purged with the new gas before the beginning of the new measurement.

5.1.6 Measuring uncertainties

The gas flow should be measured with a standard uncertainty of $\pm 2,5\%$ and the pressure with a standard uncertainty of less than $\pm 3\%$. For the exact calculation, see Annex B. The total uncertainty of the volume flow rate shall be $< 10\%$.

5.1.7 Evaluation of the measurement

Plot on a semi-logarithmic graph (similar to Figure 5) the volume flow rate, q_V , of the test pump, calculated by means of Equation (1), with respect to the inlet pressure, and plot on the same graph the volume flow rate, q_{VBP} , of the backing pump (if used), calculated from Q_{std} and p_3 , with respect to p_3 , so as to show the size of the backing pump. The range of abscissa shall cover the whole range of pressures p_1 and p_3 . The base pressures of the vacuum pump, p_{b1} , and of the backing pump, p_{b3} , shall be indicated.

The test report shall include as a minimum:

- a) type, serial number, measuring uncertainty and operational conditions of all vacuum gauges and flow meters used;
- b) type and serial number of the test pump;
- c) rotational frequency ("speed") and/or other operating conditions of the test pump;
- d) fluids and their vapour pressures at 20 °C used in the test pump;
- e) D_N (nominal diameter of the test dome and flange type);
- f) type and volume flow rate of the backing pump (if used);
- g) type of seals used upstream from the inlet flange of the test pump;
- h) type of baffles and traps employed during the test, as well as their temperatures;
- i) cooling water temperatures and water flow rate;
- j) ambient and test dome temperatures;
- k) baking time and temperatures.

5.2 Volume flow rate (pumping speed) measurement by the orifice method

5.2.1 General

The orifice method is applicable to high-vacuum pumps. Molecular flow conditions shall be present in the test dome. This method is recommended for low gas throughputs where no suitable gas flow meters are available. The orifice diameter in the test dome shall be adapted to the expected volume flow rate of the test pump in order to avoid excessively high pressures which would result in laminar flow conditions through the orifice.

5.2.2 Test dome for the orifice method

The test dome shall be cylindrical and of the shape shown in Figure 3. A wall with a (changeable) circular orifice divides the dome into two chambers. A device for bake-out that ensures uniform heating of the dome is needed.

The diameter of the thin-wall orifice plate ($\delta/d < 0,1$) shall be chosen according to the expected flow rate and shall be such that the ratio of the pressures p_d and p_e is between 3 and 30. Care shall be taken to ensure that in the orifice the mean free path, $\bar{\lambda}$, of the gas particles is not smaller than twice the orifice diameter, $2d$.

For specific values of $\bar{\lambda}$, see Annex A.

For pumps with an inlet flange diameter greater than or equal to $D_N = 100$ mm, the nominal diameter, D_N , of the dome shall be equal to the actual diameter of the inlet flange.

For pumps with an inlet flange diameter of less than $D_N = 100$ mm, the diameter of the dome shall correspond to $D_N = 100$ mm. In this case, the transition to the pump inlet flange shall be made through a 45° taper fitting in accordance with Figure 1.

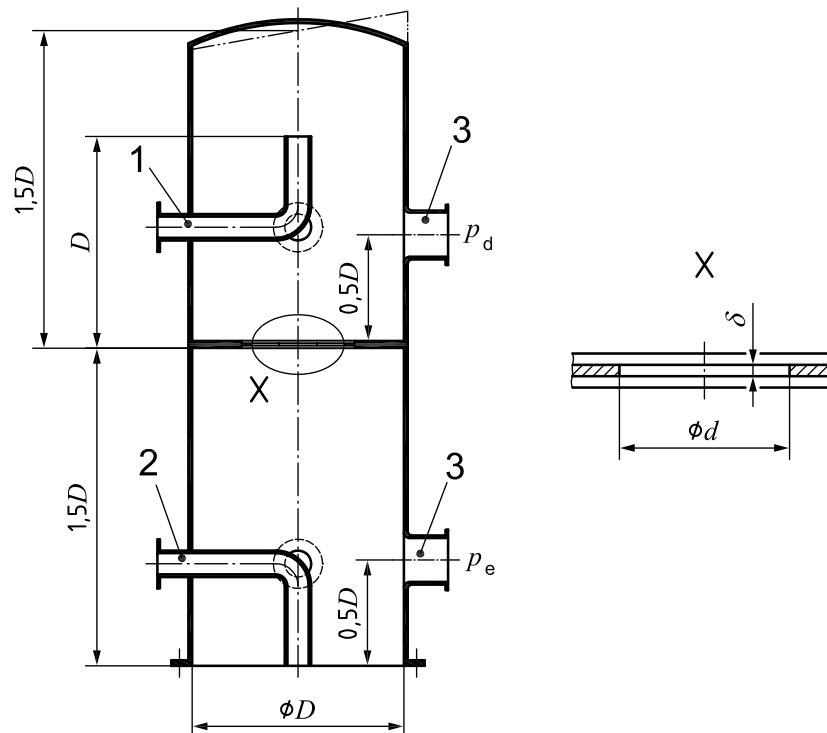

Key

- 1 gas inlet
- 2 gas inlet and temperature measuring point for T_D
- 3 vacuum gauge and mass spectrometer connections
- D inner diameter of test dome, in metres
- δ thickness of the orifice wall at the orifice diameter, in metres
- p_d, p_e pressures in the test dome for the orifice method, in pascals (or millibars)

Figure 3 — Test dome for the orifice method

5.2.3 Experimental setup

See Figure 4.

The test dome shall be clean and dry. For all connections on the high-vacuum side, bakeable knife-edge flanges are recommended.

CAUTION — Do not touch inner surfaces with your hands. Use gloves during mounting.

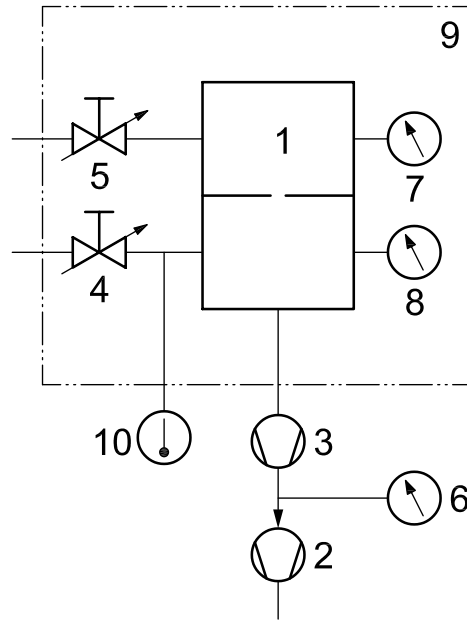

Key	
1	test dome
2	backing pump
3	test pump
4	gas inlet valve
5	gas inlet valve
6	vacuum gauge to measure p_3
7	vacuum gauge to measure p_d
8	vacuum gauge to measure p_e
9	heating jacket
10	temperature measuring point for T_D

Figure 4 — Arrangement for measuring volume flow rate (pumping speed) with orifice method

5.2.4 Determination of the volume flow rate

A thin circular orifice plate divides the test dome into two volumes (see Figure 3). The volume flow rate is given by

$$q_V = C \left(\frac{p_d - p_{bd}}{p_e - p_{be}} - 1 \right) \tag{5}$$

where C is the calculated conductance, taking into account the orifice size and the gas properties.

The base pressures, p_{bd} and p_{be} , in the upper and lower chamber of the test dome are measured after baking (see 5.4) and before admission of the gas. The conductance of the orifice with diameter, d , and thickness, δ , can be calculated using Equation (6):

$$C = \sqrt{\frac{\pi R T_D}{32 M}} \left[\frac{1}{1 + (\delta / d)} \right] d^2 \tag{6}$$

The term $1/[1 + (\delta/d)]$ is a correction factor (only valid for $\delta \ll d$) that can be defined as the average transition probability through the orifice.

Take care that the equation is used with consistent units. Inserting the values

$$R = 8,314 \text{ J/(mol}\cdot\text{K)}$$

$$M_{\text{air}} = 28,97 \times 10^{-3} \text{ kg/mol}$$

$$T_D = 293 \text{ K (20 °C)}$$

gives, in cubic metres per second,

$$C_{\text{air}} = \frac{91d^2}{1+(\delta/d)} \quad (7)$$

or, in litres per second,

$$C_{\text{air}} = \frac{91\,000d^2}{1+(\delta/d)} \quad (8)$$

where δ and d are measured in metres.

5.2.5 Measuring procedure for the orifice method

The arrangement of the measuring equipment is given in Figure 4. At the start, after baking with all inlet valves closed, the base pressures, p_{bd} and p_{be} , shall prevail in the test dome (see 5.4).

5.2.6 Adjustment of the pressure-measuring gauges

After reaching and recording the base pressures, p_{bd} and p_{be} , in the test dome, the test gas is admitted to valve (Figure 4, label 4) to check the sensitivity of the gauges (Figure 4, label 7) and (Figure 4, label 8).

Because the gas flows directly to the pump inlet, the actual pressures, $p_d - p_{bd}$ and $p_e - p_{be}$, are equal at a constant gas flow through the valve.

CAUTION — Use only dry gases (99,9 % by mass) for the measurements in order to avoid adsorption and desorption processes.

Take at least three measurements per decade of p_e with increasing pressures, beginning from a threshold value of twice that of the base pressure, p_{be} .

Calculate the ratio $(p_d - p_{bd})/(p_e - p_{be})$ for every couple of pressure values which should be equal to 1. If there are deviations from 1, the sensitivity of one gauge shall be corrected by the mean deviation factor for each decade.

After this adjustment, the test dome is pumped down to almost the base pressure and the measurement of the volume flow rate can start.

5.2.7 Measurement of the volume flow rate

The gas is admitted to the test dome through the adjustable valve (Figure 4, label 5). Take measurements with increasing pressures, starting from a threshold value of twice that of the base pressure, p_{be} . When the required pressure, p_{be} , is obtained and remains stable for the following minute to within $\pm 3\%$, this point may be regarded as valid. If pressure is unsteady due to a transient condition, wait until it stabilizes.

Take measurements at a minimum of three points per pressure decade up to $p_e = 1 \times 10^{-3}$ Pa or to a pressure at which the mean free path (see Reference [7], p. 43) of the gas molecules in the upper part of the test dome becomes less than $2d$, where d is the diameter of the orifice (see Annex A). The pressures p_d , p_e and p_3 are recorded at each measurement.

Calculate the volume flow rate, q_V , with Equation (5).

NOTE Volume flow rate measurements can be made with different gases. When the gas is changed, all pipes connected to the gas inlet valve are purged with the new gas before the beginning of the new measurement.

5.2.8 Measuring uncertainties

The pressure ratios should be measured with an uncertainty of $\leq 3\%$ and the orifice diameter with an uncertainty of $0,5\%$. If the pressure in the upper chamber rises to a value where the mean free path approaches double the

orifice diameter, the conductance grows by 3 % of the molecular flow value (see Reference [7], pp. 147–150). For the exact calculation, see Annex B. The total uncertainty of the volume flow rate shall be <10 %.

5.2.9 Evaluation of the measurement

Plot on a semi-logarithmic graph (see Figure 5) the volume flow rate, q_V , of the test pump, calculated by means of Equation (5), with respect to the inlet pressure, and plot on the same graph the volume flow rate, q_{VBP} , of the backing pump (if used), calculated from $Q = p_e q_V = C(p_d - p_e)$ and p_3 , with respect to p_3 , so as to show the size of the backing pump. The range of abscissa shall cover the whole range of pressures p_e and p_3 . The base pressures of the vacuum pump, p_{be} , and of the backing pump, p_{b3} , shall be indicated.

The test report shall include as a minimum:

- a) type, serial number, measuring uncertainty and operational conditions of all gauges used;
- b) type and serial number of the test pump;
- c) rotational frequency (“speed”) and/or other operating conditions of the test pump;
- d) fluids and their vapour pressures at 20 °C used in the test pump;
- e) D_N (nominal diameter of the test dome and flange type);
- f) type and volume flow rate of the backing pump (if used);
- g) type of seals used upstream from the inlet flange of the test pump;
- h) type of baffles and traps employed during the test, as well as their temperatures;
- i) cooling water temperatures and water flow rate;
- j) ambient and test dome temperatures;
- k) baking time and temperatures.

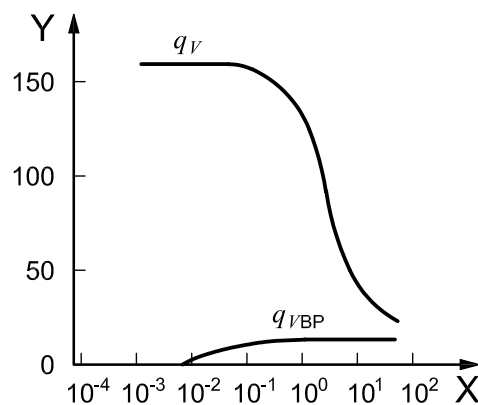

Key	
X	inlet pressure, in pascals
Y	volume flow rate, in litres per second
q_V	volume flow rate of test pump
q_{VBP}	volume flow rate of backing pump

Figure 5 — Example of volume flow rate (pumping speed) curve

5.3 Volume flow rate (pumping speed) measurement by the pump-down method

5.3.1 General

The pump-down method should be used for small pumps. The pumping speed is obtained by evacuating a test dome with the test pump. This method requires a measurement of pressure versus time as well as a knowledge of the volume of the test dome. The advantages of the method are that no gas flow needs to be measured and that automation of the procedure is easy.

However, continuous evacuation has certain disadvantages, such as those cited in the following.

- The pressure measurement can be disturbed by the response times of pressure gauges and of the data accumulation system.
- Evacuation of a vessel corresponds to an expansion of the gas out of the vessel, resulting in a cooling of the gas. As a result, the observed pressure drop originates from both the removal of gas by the pump and the cooling of the gas in the vessel. The cooling effect changes in the course of pumping down since the speed of heat transfer between gas and vessel walls depends on pressure. At atmospheric pressure, the gas expansion is close to isentropic (resulting in substantial cooling), but in the fine vacuum regime, it is close to isothermal (resulting in a quick warming up to the ambient temperature of the cooled gas).

These problems are avoided by intermittent pumping, such that the vessel is evacuated in repeated pump cycles, Δt_1 , with intermediate waiting times, Δt_2 . At the beginning of a cycle, the vessel is valved off and the pressure is recorded as initial pressure. The vessel is pumped for a certain time interval, Δt_1 , until the pressure has decreased by several per cent. The pumping process is then interrupted and the second pressure value recorded after the time interval, Δt_2 , which allows for thermal equalization. The equalization is achieved when the pressure assumes a stationary value. The pump cycle is then repeated in the same way.

Using this method for pumps with high back-streaming from the exhaust to the inlet side can increase the volume flow rate of these pumps for light gases by a purge gas effect. During the waiting time for thermal equalization, the pump reaches the base pressure with a residual gas composition similar to air at the exhaust of the pump. At the beginning of the new pump interval, this residual gas accelerates the pumping of a light gas like hydrogen. Consequently, the pump-down method cannot be recommended in such cases.

All measuring devices shall be calibrated either:

- a) in a traceable way to a vacuum primary or to a national standard; or
- b) by means of instruments of absolute measure which are traceable to the SI units and to which measurement uncertainties can be attributed.

In the case of calibrated measuring instruments, there should exist a calibration certificate in accordance with ISO/IEC 17025^[3].

5.3.2 Test dome for the pump-down method

For the measurement of the volume flow rate with the pump-down method, a test dome with a volume not smaller than the expected volume flow rate multiplied by 120 s shall be used. The dimensions of the dome in the three directions in space shall not differ by more than a factor of 10. All internal surfaces of the test dome and the connection line to the pump shall be clean and dry. The test dome shall have one suction port with a nominal diameter greater than or equal to the inlet flange of the test pump, additional ports for a gas inlet valve and one or more ports for vacuum gauges. The ports for the vacuum gauges shall not be close to the pumping port (see Figure 6).

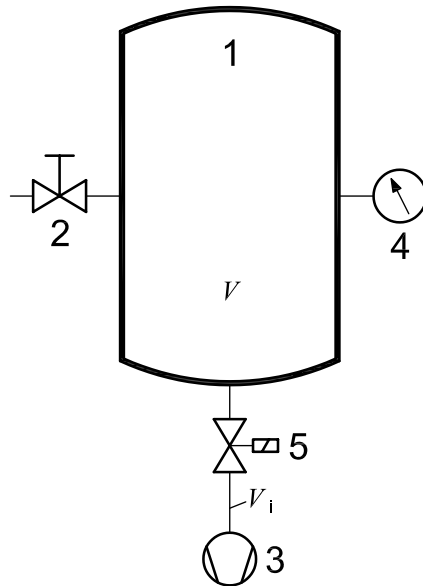

Key

- 1 test dome
- 2 gas inlet valve
- 3 test pump
- 4 vacuum gauge to measure p_{t1}, p_{t2}, p_{t3}
- 5 quick-acting valve
- V volume of test dome
- V_i volume of connection pipe between test pump and quick-acting valve

Figure 6 — Arrangement for measuring volume flow rate (pumping speed) with pump-down method

5.3.3 Quick-acting valve

The quick-acting valve should have an opening or closing time of $<0,5$ s. The measurement interval, Δt_1 , shall be large compared to this time (i.e. $\Delta t_1 > 8$ s) in order to minimize its contribution to the measurement uncertainty of the pumping speed. For an exact measurement of Δt_1 , the actual opening time of the quick-acting valve shall be measured with sufficient accuracy and included in the calculation. This opening time may deviate from the valve drive time depending on the type of valve.

Because the conductance of the valve reduces the measured volume flow rate of the test pump, a straight valve with a high cross-section should be chosen.

5.3.4 Experimental setup

The cleanness of the vacuum pump, seals and other components shall be appropriate for the expected base pressure. All components are mounted together under clean conditions in accordance with Figure 6. The vacuum pump shall be connected via the quick-acting valve to the test dome using a short connection pipe with sufficient cross-section (see 5.3.7). The valve shall be mounted closely to the pump inlet flange in order to minimize the volume, V_i , of that part of the connection line. The pipe between the valve and the test dome can be expanded to a large cross-section. The nominal diameter of the connecting elements should be greater than or equal to the inlet port of the pump. The volume, V_i , of the connection pipe between the quick-acting valve and the entry of the pumping system of the vacuum pump shall be smaller than 1 % of the volume, V , of the test vacuum vessel, i.e. $V_i < 0,01V$.

The pressure measurement shall be performed with an absolute pressure vacuum gauge. The connection pipe from the test dome to the vacuum gauge shall not exceed a length of 1 m. The nominal diameter of the pipe shall be larger than 16 mm.

5.3.5 Determination of the volume flow rate

The volume flow rate, q_V , of the vacuum pump during the pump interval, Δt_1 , between pressures p_{t_1} and p_{t_2} (assuming isothermal expansion) is given by Equation (9):

$$q_V = \frac{V}{\Delta t_1} \ln \frac{p_{t_1}}{p_{t_2}} \tag{9}$$

The uncertainty of the volume, V , of the test dome should be <0,5 %. To determine the pressures p_{t_1} and p_{t_2} as well as Δt_1 , the quick-acting valve (Figure 6, label 5) between the vacuum pump and the test dome is opened for a fixed time interval, Δt_1 .

The pressure difference, $\Delta p = p_{t_1} - p_{t_2}$, shall be chosen such that $\Delta p / p_{t_1} < 0,1$.

Equation (9) is only valid for isothermal gas expansion. After closing the quick-acting valve, the pressure p_{t_2} is falsified by the cooling effect of the nearly isentropic gas expansion during pumping. Therefore, p_{t_2} shall be measured after a waiting-time interval, Δt_2 , for temperature equalization.

The method of calculating the volume flow rate by Equation (9) contains two systematic sources of error which can be corrected.

The first source of error results from the volume, V_i , between the pump and the plate of the quick-acting valve (see Figure 6). This volume is inevitably evacuated (almost) to the base pressure of the pump, p_{b1} , at the beginning of the measurement time interval, Δt_1 . When the valve opens at the beginning of the pump interval, the evacuated volume, V_i , causes an abrupt rapid expansion of volume of the gas, V , inside the vessel into the volume V_i , and thus reduces the actual start pressure, p_{t_1} , at the pump interval to $p_{t_{1w}}$. Equation (10) corrects the pressure drop of p_{t_1} caused by this expansion:

$$p_{t_{1w}} = \frac{p_{t_1}V + p_{b1}V_i}{V + V_i} \tag{10}$$

The second source of error is a possible leakage and gas desorption of the test dome, causing an additional gas load during the waiting time for thermal equalization. To determine the influence of this effect, the pressure rise, $p_{t_3} - p_{t_2}$, in a third time interval, Δt_3 , following the thermal equalization shall be measured at a pressure <100 Pa. In this case, the influence of the leak and desorption rate on the volume flow rate can be corrected by replacing p_{t_2} in Equation (9) by the virtual pressure, $p_{t_{2w}}$.

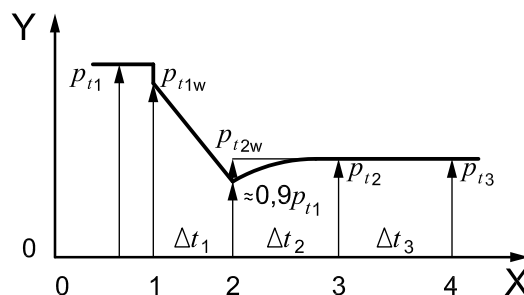

Key

X time

Y inlet pressure

$p_{t_1}, p_{t_2}, p_{t_3}$ pressures in test dome for pump-down method, measured before and after time intervals $\Delta t_1, \Delta t_2, \Delta t_3$

Figure 7 — Pressure versus time curve of pumping cycle for a volume flow rate measurement by the pump-down method

Figure 7 shows a pressure-versus-time curve of a pumping cycle for a volume flow rate measurement. At the beginning of the pump cycle (1), the initial pressure, p_{t_1} , drops quickly to p_{t_1w} by opening the quick-acting valve. The pressure is then lowered to $0,9p_{t_1}$ (2) by pumping during the time interval, Δt_1 . After closing the quick-acting valve, the pressure rises during the time interval, Δt_2 , by thermal equalization to the value p_{t_2} (3). With the pressure rise from p_{t_2} to p_{t_3} (4), the influence of the leak and desorption rate on the volume flow rate measurement can be corrected, extrapolating the slope of the curve in the time interval, Δt_3 , back to the time point (2). The corrected pressure, p_{t_2w} , is therefore obtained by Equation (11).

$$p_{t_2w} = p_{t_2} - \frac{(p_{t_3} - p_{t_2})(\Delta t_1 + \Delta t_2)}{\Delta t_3} \tag{11}$$

Inserting Equations (10) and (11) into Equation (9) gives the corrected volume flow rate.

$$q_V = \frac{V + V_i}{\Delta t_1} \ln \frac{p_{t_1w}}{p_{t_2w}} \tag{12}$$

5.3.6 Measuring procedure

The vacuum gauge and the vacuum pump at the test dome shall be operated with the quick-acting valve open until the pump reaches the base pressure and at least until the vacuum pump has reached a stable operational temperature. The vacuum pump shall exhaust against atmospheric pressure. The ambient temperature shall be kept constant within $\pm 1,5$ °C at a temperature between 18 °C and 25 °C.

With the gas inlet valve closed, the test dome is evacuated. When no further decrease in pressure is observed, record the base pressure, p_{b1} . The quick-acting valve is then closed and the test dome vented to atmospheric pressure with the test gas. Pumps with base pressures below the partial vapour pressure of water at ambient room temperature shall be measured with dry air, nitrogen or other test gases. After the gas inlet valve is closed, the pressure reading, p_{t_1} , is allowed to stabilize until it reaches a constant value (typically after 30 s to 120 s). Then the quick-acting valve is opened and, simultaneously, the time measurement for Δt_1 is started. When the relative pressure difference $(p_{t_1} - p_{t_2}) / p_{t_1}$ approaches 0,1, the quick-acting valve is closed and the time measurement for Δt_1 is stopped. The pressure p_{t_2} is recorded after the reading has stabilized at a constant value after the time interval Δt_2 (typically: $30 \text{ s} < \Delta t_2 < 120 \text{ s}$).

At pressures < 100 Pa, the influence of the leak rate and desorption rate should be measured by recording a third pressure, p_{t_3} , after a further time interval, Δt_3 , with the quick-acting valve closed.

Repetition of the intermittent pump procedure results in measurement of volume flow rate values over the complete pressure range down to the base pressure of the pump. The measurements can be performed with air or other gases. The gas type shall be specified.

5.3.7 Limits of applicability

Leak and desorption rates shall not influence the pressure too much. The second term in Equation (11) shall not exceed 1 % of p_{t_2} .

In the molecular flow regime, the conductance of the connection line between pump and test dome reduces the measured volume flow rate. To estimate this influence, the conductance of connection pipe, C , shall be calculated by means of Equation (13):

$$C = \frac{\pi}{16} \bar{c} d^2 \frac{14 + 4(l/d)}{14 + 18(l/d) + 3(l/d)^2} \quad (13)$$

where

\bar{c} is the mean thermal velocity of the gas;

d is the diameter of orifice;

l is the length of the connection pipe.

See Reference [7], pp.135–136.

The method can be used in the molecular flow regime if $C > 20q_V$. For $C \leq 20q_V$, the method can only be used for pressures at which the mean free path $\bar{l} < 0,1a$, where a is the inner diameter of the connection pipe. For values of \bar{l} , see Annex A.

5.3.8 Evaluation of the measurement

The volume flow rate is calculated using Equations (10), (11) and (12) and assigned to the mean value of the measured pressures p_{t1} and p_{t2} . For a graphical presentation, a fitted curve can be drawn through the measurement points as long as it does not deviate from the measured pumping speed values by more than 5 %. The fitted curve is the pumping speed curve of the vacuum pump.

5.3.9 Measurement uncertainty

The total uncertainty of the volume flow rate measurement shall be smaller than 10 %. If there is evidence that, without correction from p_{t1} to p_{t1w} , and from p_{t2} to p_{t2w} , the resulting measurement error of q_V is smaller than 10 %, then it can be assumed that $p_{t1w} = p_{t1}$ and $p_{t2w} = p_{t2}$. For the exact calculation, see Annex B.

5.4 Measurement of the base pressure

5.4.1 Operating conditions

The operating conditions of the vacuum pump are those given by the manufacturer (rotational frequency, lubrication fluid, cooling, etc.). The ambient temperature shall be between 18 °C and 25 °C during the whole test procedure. During the measuring time, the apparatus shall be at a stable temperature to within $\pm 1,5$ °C.

All measuring devices shall be calibrated either:

- a) in a traceable way to a vacuum primary or to a national standard, or
- b) by means of instruments of absolute measure which are traceable to the SI units and to which measurement uncertainties can be attributed.

In the case of calibrated measuring instruments, there should exist a calibration certificate in accordance with ISO/IEC 17025^[3].

For this measurement, use the arrangements from Figures 2, 4, and 6.

5.4.2 Test procedure for pumps with a base pressure $>10^{-4}$ Pa

The test dome shall be evacuated with all gas inlet valves closed over a period of 1 h to 2 h until no further pressure drop is observed in the dome and the pump has reached its equilibrium operating temperature.

If the expected base pressure is between 10^{-2} Pa and 10^{-4} Pa, the test dome shall be heated for 3 h to 120 °C. If the pump is fitted with a bake-out device, it shall be baked in accordance with the manufacturer's instructions. The bake-out of pump and test dome shall be terminated simultaneously.

The pressure, p_1 , measured 1 h after the pump and the test dome have reached their equilibrium operating temperature, is the base pressure, p_{b1} .

5.4.3 Test procedure for pumps with a base pressure $<10^{-4}$ Pa

When mounting the test dome (see Figure 2), the conditions usually required for UHV technology shall be met.

Heat the test dome, 1 h after starting the pump, to a maximum temperature of 150 °C to 300 °C. If the vacuum pump is fitted with a bake-out device, it shall be baked following the manufacturer's instructions. The temperature of the upper part of the vacuum pump shall be monitored to remain within the limits of the pump specification. The bake-out of the vacuum pump and the test dome shall be terminated simultaneously when a pressure of 100 times the expected base pressure is reached, but at the latest after 48 h of baking. The bake-out procedure shall be specified in the test report. Ionization gauges shall be degassed in accordance with the manufacturer's recommendations during and at the end of the bake-out process, at the latest 2 h before the beginning of the measurement. The outlet pressure, p_3 , of the vacuum pump shall be recorded at the same time.

The pressure, p_1 , in the test dome measured 48 h after the end of the bake-out, is the base pressure, p_{b1} , of the vacuum pump. At this time, the slope of the function of pressure against time shall not be positive.

5.4.4 Evaluation of the measurement

The test report shall include the heating procedure (time and temperature) and the base pressure, which are needed for the compression ratio and volume flow rate calculation.

5.5 Measurement of the compression ratio and the critical backing pressure

All measuring devices shall be calibrated either:

- a) in a traceable way to a vacuum primary or to a national standard; or
- b) by means of instruments of absolute measure which are traceable to the SI units and to which measurement uncertainties can be attributed.

In the case of calibrated measuring instruments, there should exist a calibration certificate in accordance with ISO/IEC 17025^[3].

5.5.1 Experimental setup

The experimental setup for the compression ratio measurement is shown in Figure 8.

The surfaces of the test dome and the used seals and flanges shall be appropriate for the expected base pressure. At pressures $<10^{-4}$ Pa, bakeable knife-edge flanges shall be used.

It is recommended that a set of different pressure gauges be used to measure the whole range of pressure. For values of $p_1 < 10^{-8}$ Pa, a mass spectrometer should be used.

If several ionization gauges are used, a straight connection between their ion sources shall be avoided.

To get a low base pressure of about 10^{-2} Pa on the fore vacuum side, a turbomolecular pump between the backing pump and the conductance valve is recommended. A pressure gauge (Figure 8, label 6) shall be mounted as near as possible to the outlet of the test pump in a straight uniform section on the backing line, the diameter of which is equal to that of the test pump outlet. The connection pipe of the pressure gauge shall be perpendicular to the outlet line axis and flash with its inside wall. It shall be clearly displaced upstream from the gas admission valve (Figure 8, label 4). An adjustable valve for throttling gas flow to the backing pump should be installed to save test gas. The test gases used shall have a purity of 99,999 % by mass.

5.5.2 Determination of the compression ratio and the critical backing pressure

The compression ratio, K_0 , is defined as

$$K_0 = \frac{p_3 - p_{b3}}{p_1 - p_{b1}} \quad (14)$$

where p_{b1} and p_{b3} are the base pressures of the test pump and the backing pump. To measure the compression ratio, gas is admitted to the outlet duct of the test pump and pressures p_1 and p_3 are measured.

The maximum pressure, p_3 , against which the test pump (Figure 8, label 3) can exhaust continuously is the critical backing pressure, p_c .

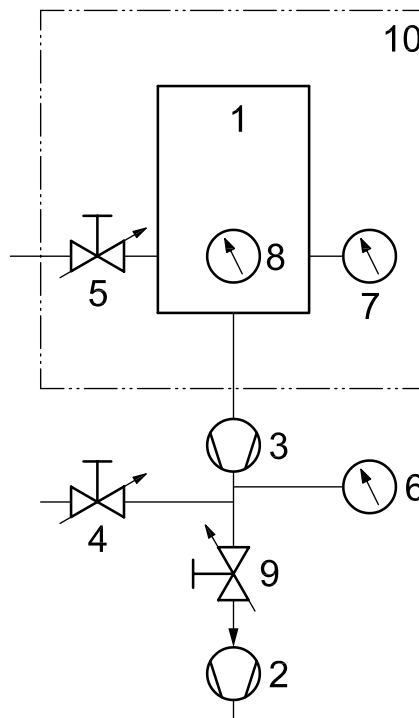

Key

1	test dome	6	vacuum gauge to measure p_3
2	backing pump	7	vacuum gauge to measure p_1
3	test pump	8	vacuum gauge or mass spectrometer
4	gas inlet valve	9	conductance valve
5	gas inlet valve	10	heating jacket (optional)

Figure 8 — Arrangement for compression ratio and critical backing pressure measurement

5.5.3 Measurement procedure

For each test gas, first wait until the base pressure, p_{b1} , prevails in the test dome (see 5.4). The corresponding backing pressure, p_{b3} , shall be small compared to the pressure rise for the first measuring point caused by the gas inlet. The ambient temperature shall be constant within $\pm 1,5$ °C during the measuring process.

Open the gas inlet valve (4) progressively, such that the pressure, p_3 , increases gradually. The values of the backing pressure, p_3 , and the inlet pressure, p_1 , shall be recorded simultaneously when they are stable within ± 5 % over 1 min. Measurements shall be recorded at three points per decade of the backing pressure.

Continue with the procedure until p_3 reaches the critical backing pressure, p_c . The conditions for the critical backing pressure are defined either by the manufacturer of the test pump or by the specific standard for the test pump type.

Depending on the type, compression ratio measurements may be made with throughput “0” or specified throughputs of the test pump if this is provided for in the pump instruction manual or in its specific standard.

NOTE Compression ratio measurements can be made with different gases. When the gas is changed, all pipes connected to the gas inlet valve are purged with the new gas before the beginning of the measurement.

5.5.4 Measurement uncertainty

The measurement uncertainty of the compression ratio can only be estimated for values $p_1 \gg p_{b1}$ and $p_3 \gg p_{b3}$. It should be $\pm 20\%$ or less.

5.5.5 Evaluation of the measurements

Plot the inlet pressure, $p_1 - p_{b1}$, against $p_3 - p_{b3}$, both on logarithmic scales. Then plot the compression ratio, K_0 , against $p_3 - p_{b3}$, also on logarithmic scales. Curves for different test gases shall be clearly indicated on each diagram.

NOTE The curves in Figure 9 crossing the abscissa between 10 Pa and 200 Pa are compression ratio curves of normal turbomolecular pumps with critical backing pressures, p_c , for different gases at pressures of the order of 100 Pa. The three curves crossing the abscissa at about one order of 10 higher are those of turbomolecular pumps with Holweck stages and corresponding p_c values.

5.5.6 Specific recommendations for extremely high compression ratio measurements

For extremely high compression ratio measurements, where the base pressure is higher than the inlet partial pressure rise of the gas that is admitted to the fore vacuum side, a mass spectrometer shall be used to measure this partial pressure. Because the inlet pressure range covers six decades and more, the use, in parallel, of a spinning rotor gauge, a Bayard-Alpert ionization gauge, and a mass spectrometer for pressure measurement is recommended.

For calibration of both of the latter, admit test gas via the gas inlet valve (5) into the test dome to increase the pressure in the test dome in several stages. Comparing the readings of the different gauges, calibration factors for the ionization gauge and the mass spectrometer can be determined.

It is advisable that the calibrating step be done after the compression ratio measurements are ready.

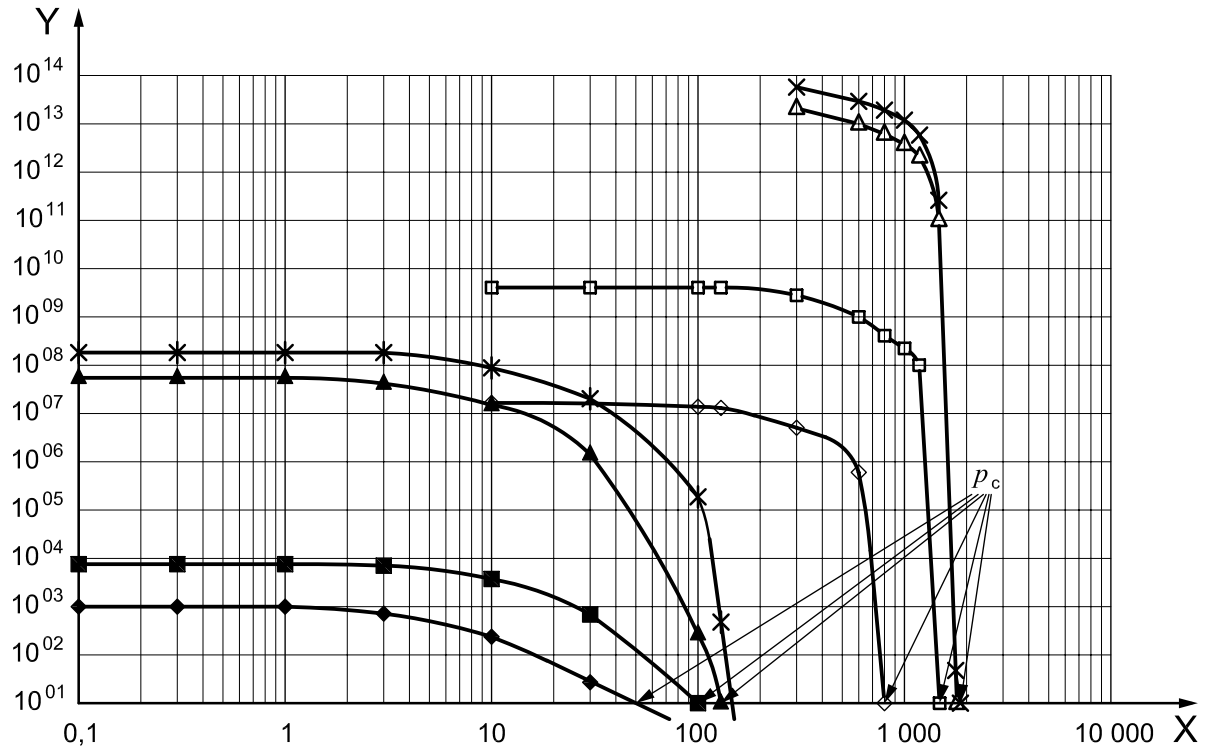

Key

- X backing pressure, in pascals
- Y compression ratio
- p_c critical backing pressure, in pascals

Figure 9 — Compression ratio curves of turbomolecular pumps

Annex A (informative)

Mean free path of some important gases

The product of the mean free path and pressure is constant. The values for the gases in Table A.1 are valid for $T = 293,15 \text{ K}$ ($20 \text{ }^\circ\text{C}$) (see Reference [7], p. 921).

Table A.1 — Mean free path of some important gases

Gas	Mean free path ($\bar{l} \times p$) m·Pa	Gas	Mean free path ($\bar{l} \times p$) m·Pa
H ₂	$11,5 \times 10^{-3}$	Xe	$3,6 \times 10^{-3}$
N ₂	$5,9 \times 10^{-3}$	Hg	$3,1 \times 10^{-3}$
He	$17,5 \times 10^{-3}$	CO	$6,0 \times 10^{-3}$
Ne	$12,7 \times 10^{-3}$	CO ₂	$4,0 \times 10^{-3}$
Ar	$6,4 \times 10^{-3}$	HCl	$4,4 \times 10^{-3}$
Air	$6,65 \times 10^{-3}$	NH ₃	$4,3 \times 10^{-3}$
Kr	$4,9 \times 10^{-3}$	Cl ₂	$2,8 \times 10^{-3}$

Annex B (informative)

Measuring uncertainties

B.1 General remarks

The calculation of the uncertainties should be performed in accordance with the ISO/IEC Guide 98-3^[5].

The following important points shall be taken into account:

- a physical quantity has a value X and an uncertainty;
- the standard uncertainty is denoted by the symbol u_X and corresponds to the case where, within a probability of 68 %, the true value normally lies in the interval between $X - u_X$ and $X + u_X$;
- for results, the expanded uncertainty should be given, denoted by U_X and calculated by multiplying the standard uncertainty by a factor of 2;
- the true value then lies, within a probability of 95 %, in the interval between $X - u_X$ and $X + u_X$.

When a physical quantity, Y , is derived from various uncorrelated input quantities, X_i , its uncertainty, u_Y , is obtained by the rules of error propagation, using a quadratic addition of the individual terms.

$$u_Y = \sqrt{\sum_i \left(\frac{dY}{dX_i} u_{X_i} \right)^2} \quad (\text{B.1})$$

B.2 Uncertainty of the volume flow rate measurement by the throughput method

See 5.1.

By applying Equation (B.1) to Equation (1), $q_V = Q/(p_1 - p_b)$, and neglecting the base pressure, p_b , the uncertainty of the volume flow rate is obtained as follows:

$$u_{q_V} = \sqrt{\left(\frac{u_Q}{p_1} \right)^2 + \left(\frac{Q u_{p_1}}{p_1^2} \right)^2} \quad (\text{B.2})$$

The relative uncertainty is obtained by dividing Equation (B.2) by Equation (1) as follows:

$$\frac{u_{q_V}}{q_V} = \sqrt{\left(\frac{u_Q}{Q} \right)^2 + \left(\frac{u_{p_1}}{p_1} \right)^2} \quad (\text{B.3})$$

EXAMPLE $\frac{u_Q}{Q} = 0,025$; $\frac{u_{p_1}}{p_1} = 0,03 \Rightarrow \frac{u_{q_V}}{q_V} = 0,039$; $\frac{u_{q_V}}{q_V} = 3,9 \%$

B.3 Uncertainty of the volume flow rate measurement by the orifice method

See 5.2.

By applying Equation (B.1) to Equation (5),

$$q_V = C \left(\frac{p_d - p_{bd}}{p_e - p_{be}} - 1 \right)$$

and neglecting the base pressures p_{bd} and p_{be} with respect to p_d and p_e , the uncertainty of the volume flow rate is obtained from Equation (B.4):

$$u_{q_V} = \sqrt{\left(\frac{p_d - p_e}{p_e} u_C \right)^2 + \left(\frac{C}{p_e} u_{p_d} \right)^2 + \left(\frac{p_d C}{p_e^2} u_{p_e} \right)^2} \quad (\text{B.4})$$

The relative uncertainty is obtained by dividing Equation (B.4) by Equation (5) and neglecting the base pressures p_{bd} and p_{be} with respect to p_d and p_e , as in Equation (B.5):

$$\frac{u_{q_V}}{q_V} = \sqrt{\left(\frac{u_C}{C} \right)^2 + \left[u_{p_d} / p_d \left(1 - \frac{p_e}{p_d} \right) \right]^2 + \left[u_{p_e} / p_e \left(1 - \frac{p_e}{p_d} \right) \right]^2} \quad (\text{B.5})$$

EXAMPLE

Pressure ratio $\frac{p_d}{p_e} = 3$ (see 5.2); $\frac{u_C}{C} = 0,01$; $\frac{u_{p_d}}{p_d} = 0,025$ and $\frac{u_{p_e}}{p_e} = 0,025 \Rightarrow \frac{u_{q_V}}{q_V} = 0,0537$; $\frac{u_{q_V}}{q_V} = 5,37\%$.

With higher pressures in the upper test dome chamber, the mean free path tends towards $2d$, i.e. twice the orifice diameter. For $\bar{l} = 2d$, the conductance of the orifice grows by 3 % compared to the molecular flow regime (see Reference [7], pp. 147–150), which leads to $u_C/C = 0,04$ and, for the example above, to a value $u_{q_V} / q_V = 0,664$; $u_{q_V} / q_V = 6,64\%$, a value smaller than the required limit of 10 %.

B.4 Uncertainty of the volume flow rate measurement by the pump-down method

See 5.3.

For the uncertainty calculations in Equation (12)

$$q_V = \frac{V + V_i}{\Delta t_1} \ln \frac{p_{t_1w}}{p_{t_2w}}$$

the following approximations are made:

- a) $V + V_i = V$; $V_i/\Delta t_1$ becomes negligible with respect to the first term of Equation (12);
- b) let $\Delta p = p_{t_1w} - p_{t_2w}$ and $\Delta p / p_{t_2w} < 1$; then

$$\ln \left(\frac{p_{t_1w}}{p_{t_2w}} \right) = \ln \left(1 + \frac{\Delta p}{p_{t_2w}} \right)$$

is developed in sequence, and terms with a power higher than 1 are neglected.

It therefore follows that

$$\ln\left(1 + \frac{\Delta p}{p_{t_2w}}\right) \approx \frac{\Delta p}{p_{t_2w}}$$

and

$$q_V \approx \frac{V}{\Delta t_1} \frac{\Delta p}{p_{t_2w}} \quad (\text{B.6})$$

By applying Equation (B.1) to Equation (12), the uncertainty of the volume flow rate is obtained as follows:

$$u_{q_V} = \sqrt{\left(\frac{\Delta p u_V}{\Delta t_1 p_{t_2w}}\right)^2 + \left(\frac{V u_{\Delta p}}{\Delta t_1 p_{t_2w}}\right)^2 + \left(\frac{V \Delta p u_{\Delta t_1}}{\Delta t_1^2 p_{t_2w}}\right)^2 + \left(\frac{V \Delta p u_{p_{t_2w}}}{\Delta t_1 p_{t_2w}^2}\right)^2} \quad (\text{B.7})$$

The relative uncertainty is obtained by dividing Equation (B.7) by Equation (B.6) as follows:

$$\frac{u_{q_V}}{q_V} = \sqrt{\left(\frac{u_V}{V}\right)^2 + \left(\frac{u_{\Delta p}}{\Delta p}\right)^2 + \left(\frac{u_{\Delta t_1}}{\Delta t_1}\right)^2 + \left(\frac{u_{p_{t_2w}}}{p_{t_2w}}\right)^2} \quad (\text{B.8})$$

The terms u_V/V and $u_{p_{t_2w}}/p_{t_2w}$ are of the order of 0,01.

Because of the delay time of the quick-acting valve for opening and closing, the term $u_{\Delta t_1}/\Delta t_1$ is of the order of 0,05.

The main uncertainty term is $u_{\Delta p}/\Delta p$.

Statistical uncertainties are the resolution and the fluctuations of displayed pressures.

Systematic uncertainties: zero deviation of the pressure measurement does not influence Δp .

Span deviation can be neglected because it disappears when creating the ratio p_{t_1w}/p_{t_2w} .

Linearity deviations cause the main uncertainty of Δp .

EXAMPLE

$$\frac{u_V}{V} = 0,005 ; \frac{u_{\Delta p}}{\Delta p} = 0,07 ; \frac{u_{\Delta t_1}}{\Delta t_1} = 0,05 \text{ and } \frac{u_{p_{t_2w}}}{p_{t_2w}} = 0,01$$

$$\frac{u_{q_V}}{q_V} = \sqrt{0,005^2 + 0,07^2 + 0,05^2 + 0,01^2} = 0,0867$$

$$\frac{u_{q_V}}{q_V} = 8,67 \%$$

Bibliography

- [1] ISO 3529-1:1981, *Vacuum technology — Vocabulary — Part 1: General terms*
- [2] ISO 14617 (all parts), *Graphical symbols for diagrams*
- [3] ISO/IEC 17025, *General requirements for the competence of testing and calibration laboratories*
- [4] ISO 80000-4:2006, *Quantities and units — Part 4: Mechanics*
- [5] ISO/IEC Guide 98-3, *Uncertainty of measurement — Part 3: Guide to the expression of uncertainty in measurement (GUM:1995)*
- [6] PUPP, W., HARTMANN, H.K., editors. *Handbuch Vakuumtechnik: Grundlagen und Anwendungen* [Vacuum technology handbook: Principles and applications]. Munich: Hanser, 1991. 558 p.
- [7] JOUSTEN, K., editor. *Handbook of vacuum technology*, BENJAMIN NAKHOSTEEN, C., translator. Weinheim: Wiley-VCH, 2008. 1 002 p.

www.iso.org

© 2010 International Organization for Standardization

www.iso.org

ICS 23.160

Price based on 26 pages