**Powered ride-on turf care equipment —
Roll-over protective structures (ROPS) —
Test procedures and acceptance criteria**

*Équipement automoteur à conducteur porté pour l'entretien du gazon —
Structures de protection contre le retournement (ROPS) — Modes
opératoires d'essai et critères d'acceptation*



PDF disclaimer

This PDF file may contain embedded typefaces. In accordance with Adobe's licensing policy, this file may be printed or viewed but shall not be edited unless the typefaces which are embedded are licensed to and installed on the computer performing the editing. In downloading this file, parties accept therein the responsibility of not infringing Adobe's licensing policy. The ISO Central Secretariat accepts no liability in this area.

Adobe is a trademark of Adobe Systems Incorporated.

Details of the software products used to create this PDF file can be found in the General Info relative to the file; the PDF-creation parameters were optimized for printing. Every care has been taken to ensure that the file is suitable for use by ISO member bodies. In the unlikely event that a problem relating to it is found, please inform the Central Secretariat at the address given below.



COPYRIGHT PROTECTED DOCUMENT

© ISO 2009

All rights reserved. Unless otherwise specified, no part of this publication may be reproduced or utilized in any form or by any means, electronic or mechanical, including photocopying and microfilm, without permission in writing from either ISO at the address below or ISO's member body in the country of the requester.

ISO copyright office
Case postale 56 • CH-1211 Geneva 20
Tel: + 41 22 749 01 11
Fax + 41 22 749 09 47
E-mail copyright@iso.org
Web www.iso.org

Published in Switzerland

Contents

Page

Foreword.....	iv
Introduction	v
1 Scope	1
2 Normative references	1
3 Terms, definitions and symbols	1
4 Test apparatus and equipment	3
4.1 Test equipment for horizontal loading	3
4.2 Test equipment for vertical crush loading	3
4.3 Other measuring apparatus	3
5 Preparation for strength testing	4
5.1 Purpose	4
5.2 Preparation rules for governing testing	4
6 Test procedures	4
6.1 Test sequence	4
6.2 Horizontal loading	5
6.3 Vertical crushing test	9
6.4 Observations during testing	10
7 Deflection-limiting volume (DLV)	10
8 Tolerances	12
9 Acceptance conditions	12
9.1 General requirements	12
9.2 Deflection-limiting volume/ground plane	12
9.3 Horizontal overload test for energy-absorbing ROPS	13
9.4 Vertical crush overload test	14
9.5 Cold weather embrittlement	14
10 Extension to other machines	16
11 Labelling	16
12 Test report	16
Annex A (normative) Requirements for providing resistance to brittle fracture of ROPS at reduced operating temperature	17
Annex B (informative) ROPS standards judged to provide operator protection comparable to this International Standard	19
Annex C (informative) Test report for roll-over protective structure	20
Bibliography	22

Foreword

ISO (the International Organization for Standardization) is a worldwide federation of national standards bodies (ISO member bodies). The work of preparing International Standards is normally carried out through ISO technical committees. Each member body interested in a subject for which a technical committee has been established has the right to be represented on that committee. International organizations, governmental and non-governmental, in liaison with ISO, also take part in the work. ISO collaborates closely with the International Electrotechnical Commission (IEC) on all matters of electrotechnical standardization.

International Standards are drafted in accordance with the rules given in the ISO/IEC Directives, Part 2.

The main task of technical committees is to prepare International Standards. Draft International Standards adopted by the technical committees are circulated to the member bodies for voting. Publication as an International Standard requires approval by at least 75 % of the member bodies casting a vote.

Attention is drawn to the possibility that some of the elements of this document may be the subject of patent rights. ISO shall not be held responsible for identifying any or all such patent rights.

ISO 21299 was prepared by Technical Committee ISO/TC 23, *Tractors and machinery for agriculture and forestry*, Subcommittee SC 13, *Powered lawn and garden equipment*.

Introduction

The testing of protective structures on machines is aimed at minimizing the frequency and severity of operator crushing injury resulting from accidental overturning during operation.

This International Standard enables a machine's roll-over protective structure (ROPS) to be tested by the application of static loads that simulate the actual loads which can be imposed on the cab or frame when the machine overturns without free-fall. Observations can be made on the strength of the structure, the brackets attaching it to the machine and those machine parts that could be affected by the load imposed on the structure.

Clause 6 contains testing alternatives for energy-absorbing and rigid ROPS. Field overturn experiences have demonstrated that when conservative, conventional ROPS design and test strategies are applied to small, low-mass vehicles, there is frequently little or no permanent deformation to the ROPS when the small vehicle overturns. Furthermore, standard structural steel shapes are not always incrementally sized to accommodate an efficient design for low-mass vehicles. Consequently, there is opportunity to more efficiently design and apply ROPS to small vehicles by the utilization of a rigid, non-energy-absorbing design.

Until now, there has been no ROPS International Standard covering the field of application of powered ride-on turf care machinery, and it was therefore necessary for the industry to employ standards from other fields of application to test this type of machinery. For information, Annex B lists those standards which have been employed in the past to determine the performance of ROPS for powered ride-on turf care machinery and which have been judged to provide operator protection comparable to that specified in this International Standard.

Powered ride-on turf care equipment — Roll-over protective structures (ROPS) — Test procedures and acceptance criteria

1 Scope

This International Standard defines test procedures and acceptance criteria for the roll-over protective structures (ROPS) of powered ride-on turf care machinery with a mass of 3 000 kg or less.

It is not applicable to stand-on or sulky type machines, nor to self-propelled machinery and tractors used in agriculture, forestry or construction applications.

NOTE Product-specific standards such as ISO 5395 specify whether or not a certain type of machine is to be fitted with a ROPS and these can include additional information on aspects related to ROPS, e.g. seat-belt anchorages and seat belts.

2 Normative references

The following referenced documents are indispensable for the application of this document. For dated references, only the edition cited applies. For undated references, the latest edition of the referenced document (including any amendments) applies.

ISO 5353, *Earth-moving machinery, and tractors and machinery for agriculture and forestry — Seat index point*

ISO 898-1, *Mechanical properties of fasteners made of carbon steel and alloy steel — Part 1: Bolts, screws and studs with specified property classes — Coarse thread and fine pitch thread*¹⁾

ISO 898-2, *Mechanical properties of fasteners — Part 2: Nuts with specified proof load values — Coarse thread*

ASTM A370, *Standard test methods and definitions for mechanical testing of steel products*

3 Terms, definitions and symbols

For the purposes of this document, the following terms, definitions and symbols (see Table 1) apply.

3.1 attachment

device designed for mounting only on a specific machine to perform a specific task

3.2 horizontal loading test

application of a horizontal load to the rear, front and sides of a ROPS

1) To be published. (Revision of ISO 898-1:1999)

**3.3
machine mass**

mass of the machine in working order, not including the operator, with all fluid levels full and with ROPS

NOTE The machine mass includes the heaviest configuration of attachments.

**3.4
reference mass**

m_t
mass, not less than the machine mass, used by the manufacturer to calculate the loading energies and forces to be applied in the tests

NOTE Adapted from ISO 5700:2006, definition 3.3.

**3.5
reference plane**

vertical plane generally longitudinal to the machine and passing through the seat index point (SIP) as defined in ISO 5353

**3.6
roll-over protective structure
ROPS**

framework protecting operators of turf care machinery that minimizes the likelihood of crushing injury resulting from accidental overturning during operation

NOTE 1 The ROPS is characterized by the provision of space for a deflection-limiting volume, either inside the envelope of the structure or within a space bounded by a series of planes from the outer edges of the structure to any part of the machine that might come into contact with flat ground; the structure is capable of supporting the mass of the machine in the overturned position.

NOTE 2 A ROPS may be designed and tested as a rigid ROPS or an energy-absorbing ROPS. A rigid ROPS, like an energy-absorbing ROPS, must be geometrically designed to protect the prescribed deflection-limiting volume. The primary difference is the static force resistance requirements in lieu of energy absorbing horizontal loads.

NOTE 3 The ROPS may be front- or rear-mounted, fixed or foldable (e.g. hinged or telescoping).

NOTE 4 Adapted from ISO 5700:2006, definition 3.1.

**3.7
turf care machinery**

machines used in the care and maintenance of predominately grassy areas, including golf courses, sports fields and lawns

**3.8
vertical crushing test**

application of a vertical load through a beam placed laterally across the uppermost members of the ROPS

Table 1 — Symbols

Symbol	Description	Unit
D	Deflection of the ROPS at the point of, and in line with, the load application	mm
E_{ll}	Energy input to be absorbed during longitudinal loading	J
E_{is}	Energy input to be absorbed during side loading	J
F	Static load force	N
F_{max}	Maximum static load force occurring during loading with the exception of the overload	N
F_v	Vertical crush load force	N
L	Length of forward projection of ROPS	mm
m_t	Reference mass	kg
W	External width of ROPS	mm

4 Test apparatus and equipment

4.1 Test equipment for horizontal loading

4.1.1 General

The test equipment shall enable horizontal loading to be applied to the ROPS. Provision shall be made for the load to be uniformly distributed in the direction of loading and along a beam having a maximum length of 700 mm. This stiff beam shall have a maximum vertical face dimension of 150 mm. The edges of the beam in contact with the ROPS shall be rounded, with a maximum radius of 50 mm.

The beam shall be capable of being adjusted to any angle in relation to the load direction, in order for it to be able to follow the angular variations of the ROPS load-bearing surface as it deflects.

Universal joints, or equivalent, shall be incorporated to ensure that the loading device does not constrain the structure in rotation or translation in any direction other than the loading direction.

The deviation in direction of the force shall not exceed

- $\pm 2^\circ$ at the start of the test under zero load, and
- 10° above or 20° below horizontal during testing under load.

The deflection rate shall be slow (< 5 mm/s) so that the load can at all times be considered “static”.

4.1.2 Apparatus for measuring energy absorbed by the ROPS

The force vs. deflection curve shall be plotted continuously in order to determine the energy absorbed by the ROPS. Measurement of the force and deflection at the point where the load is applied to the ROPS is not required; however, force and deflection shall be measured simultaneously and co-linearly.

The point of origin of deflection measurements shall be selected so that only the energy absorbed by the ROPS or the deflection of certain parts of the machine, or both, is measured. The energy absorbed by deflection or slipping of the anchoring, or both, shall not be included.

4.2 Test equipment for vertical crush loading

The test equipment shall be capable of exerting a downward force on the ROPS through a rigid beam up to a maximum of 250 mm wide, connected to the load-applying mechanism by means of universal pin joints. Suitable axle stands shall be provided so that the machine's tyres do not bear the vertical crush load force. See Figure 6.

4.3 Other measuring apparatus

A device for checking that the ROPS has not entered the deflection-limiting volume (DLV), (see Clause 7), and that this volume has remained within the ROPS protection during testing, shall be used.

5 Preparation for strength testing

5.1 Purpose

Strength testing is intended to simulate such loads as are imposed on a ROPS when the machine overturns. These tests enable observations to be made on the strength of the ROPS and any brackets attaching it to the machine, as well as on any parts of the machine transmitting the test load.

5.2 Preparation rules for governing testing

The preparation for testing the ROPS is governed by the following general rules.

- a) The ROPS shall be to production specifications and shall be fitted to the appropriate machine model chassis in accordance with the manufacturer's declared attachment method. A complete machine is not required for the evaluation; however, the machine frame and ROPS mounting shall represent an operating installation.
- b) The assembly shall be secured to the bedplate so that the members connecting the assembly and the bedplate do not deflect significantly in relation to the ROPS under loading. The assembly shall not receive any support from the bedplate under loading other than that due to the initial attachment.
- c) Components that could create a hazard in the DLV shall also be fitted so that they can be examined to ascertain whether the requirements of the acceptance conditions have been fulfilled.
- d) All detachable windows, panels, canopies, and removable non-structural fittings shall be removed so that they do not contribute to the strength of the ROPS. In cases where it is possible to fix doors and windows open or remove them during work, they shall be either removed or fixed open for the test, so that they do not add to the strength of the ROPS. It shall be noted whether, in this position, they would create a hazard for the driver in the event of overturning.
- e) A track width setting for the rear wheels, if present, shall be chosen such that no interference exists with the ROPS during the tests. The assembly shall be supported and secured or modified so that all the test energy is absorbed by the ROPS and its attachment to the machine's rigid components.
- f) If, during the test procedure, any part of the machine restraining equipment breaks or moves, the test procedure shall be restarted.
- g) No repairs or adjustments of the machine or the ROPS are allowed during the test procedure.
- h) The ROPS shall be instrumented with the necessary equipment to obtain the required force-deflection data.

6 Test procedures

6.1 Test sequence

If an energy-absorbing or rigid ROPS is fabricated from materials meeting the cold weather embrittlement resistance requirements specified in Annex A, all the ROPS loadings may be conducted at ambient temperature. If an energy-absorbing or rigid folding ROPS is fabricated from materials not meeting the cold weather embrittlement resistance requirements specified in Annex A, all the ROPS loadings shall be conducted at $-18\text{ }^{\circ}\text{C}$.

NOTE This test procedure was developed for two- and four-post structures. For other designs, adaptation of the procedure could be necessary.

ROPS assembly 1 loadings

- a) longitudinal loading from the front, applied at either side;
- b) side loading from the side opposite to the applied longitudinal load;

c) vertical crush loading.

ROPS assembly 2 loadings

d) longitudinal loading from the rear, applied at either side;

e) side loading from the side opposite to the applied longitudinal load;

f) vertical crush loading.

See also Figure 1.

6.2 Horizontal loading

6.2.1 Longitudinal loading

Apply the longitudinal load in a plane parallel to the reference plane (see Figure 2). The load application point shall be that part of the ROPS likely to hit the ground first in a longitudinal overturning incident (normally the upper edge). The vertical plane in which the load is applied is located at a distance of one-sixth the external width of the ROPS, inwards from the outside, as shown in Figure 3, or as close as possible depending on ROPS configuration. If the ROPS is curved or protruding at this point, add wedges enabling the load to be applied to it, but do so in a way that will not reinforce the ROPS.

The central pivot of an articulated machine shall be supported and securely mounted as appropriate for all test procedures. For the side-loading test procedure, the pivot shall also be propped from the side opposite the loading. Only the frame portion to which the ROPS is mounted need be used.

The energy absorbed, E_{ij} , in joules, by the ROPS during the test shall be at least

$$E_{ij} = 1,6 \cdot m_t$$

Alternatively, the static load force, F , in newtons, of the rigid ROPS during the test shall be at least

$$F = 20 \cdot m_t$$

Maintain this force at least 5 s after the cessation of any visually detectable movement of the ROPS.

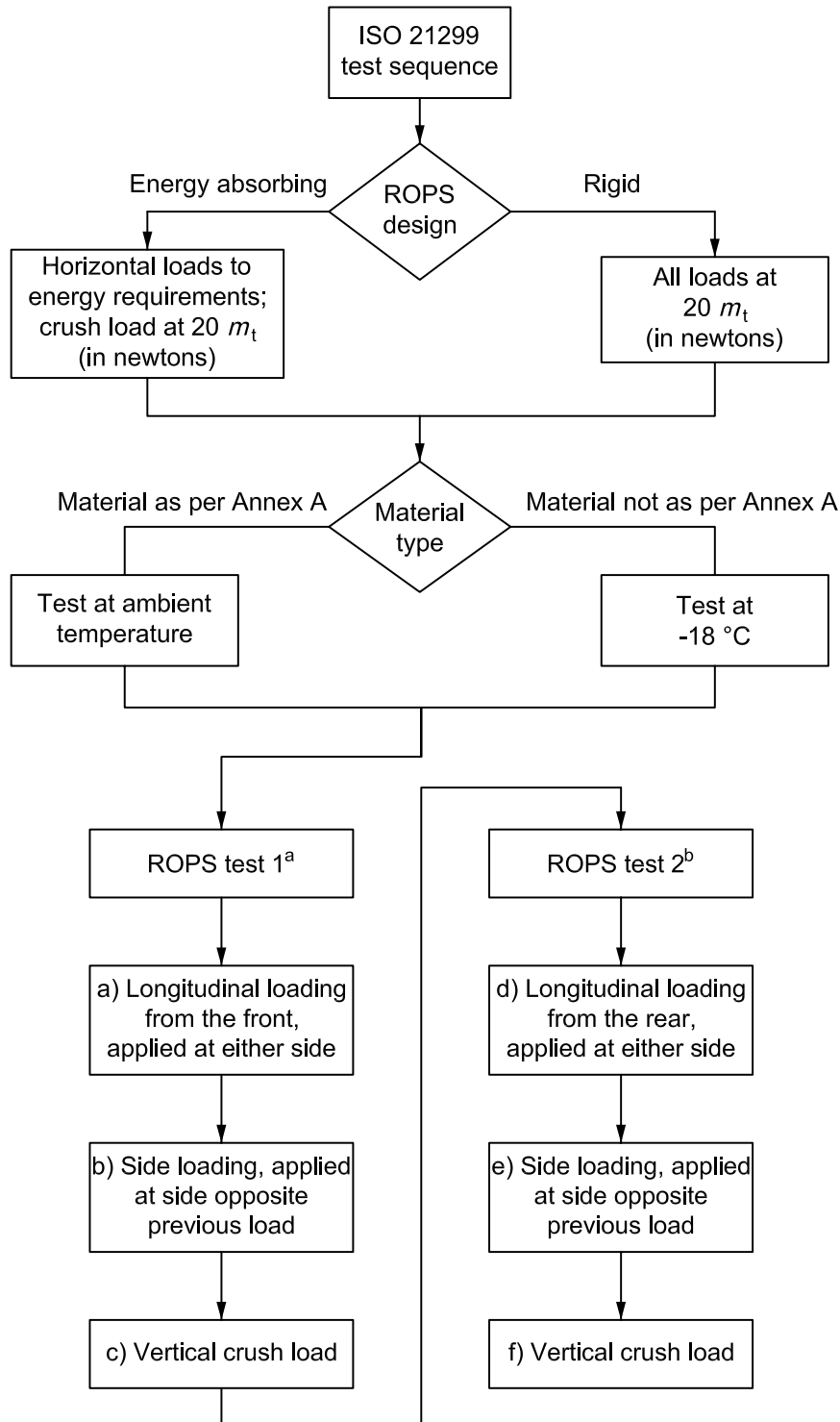

^a If tests are performed using one ROPS assembly, the test load sequence shall be a), d), e), and f). For test loads a) and d), loads shall be applied at opposite sides.

^b A second chassis may be used for the second ROPS test.

Figure 1 — ROPS test sequence

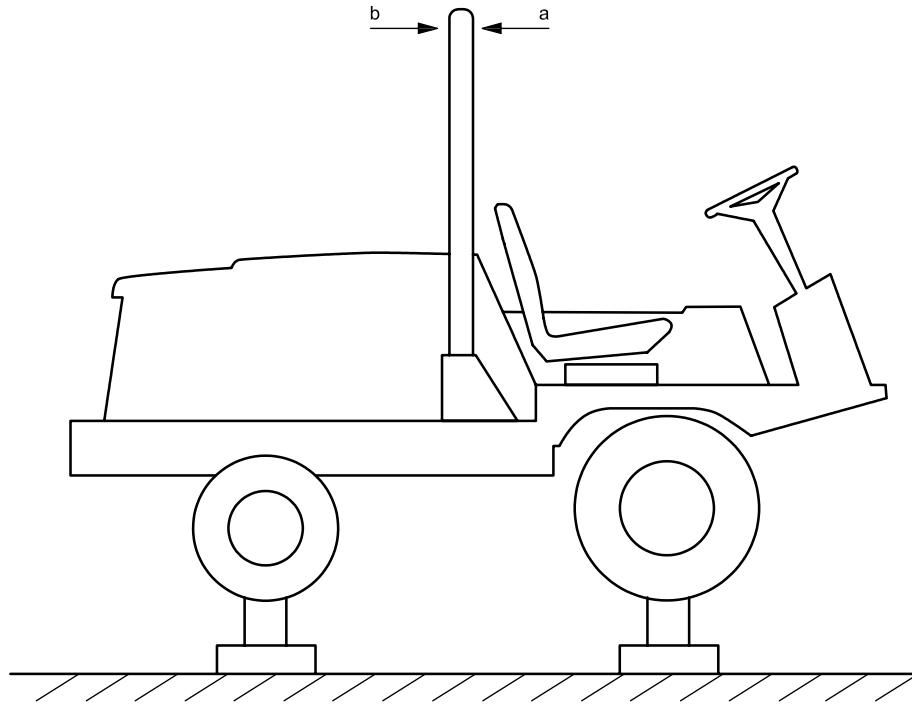

- a Direction of front longitudinal load.
- b Direction of rear longitudinal load.

Figure 2 — Longitudinal loading — Front and rear

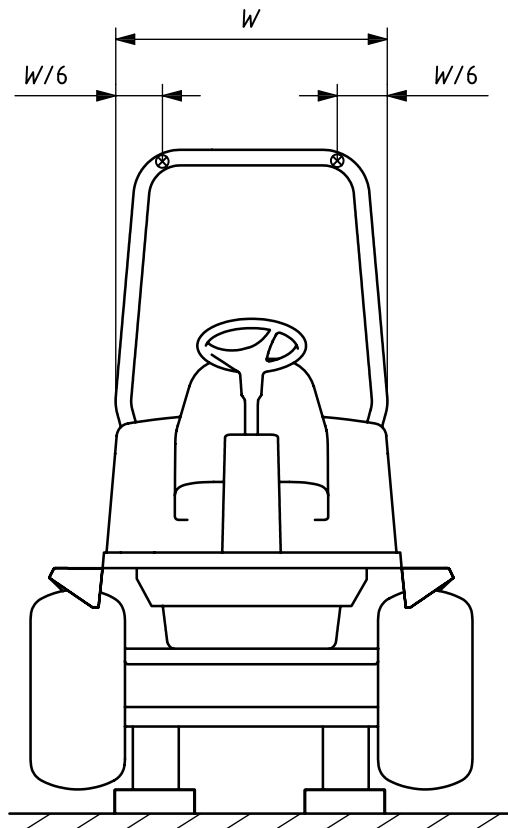

Key

W external width of ROPS

Figure 3 — Locations for front and rear loads

6.2.2 Side loading

For a cab or four-post ROPS, apply the load horizontally, in a vertical plane perpendicular to the reference plane at seat index point (SIP). See Figure 4. The SIP shall be determined in accordance with ISO 5353.

The load application point is that part of the ROPS likely to hit the ground first in a sideways overturning accident (normally the upper edge).

For two-post ROPS, apply the load in line with the centreline of the top cross member.

For two-post ROPS with a forward projection, apply the load one-third of the distance from the back of the ROPS to the front of the forward projection, as defined in Figure 5.

The energy absorbed, E_{is} , in joules, by the ROPS during the test shall be at least

$$E_{is} = 1,75 \cdot m_t$$

Alternatively, the static load force, F , in newtons, of the rigid ROPS during the test shall be at least

$$F = 20 \cdot m_t$$

Maintain this force at least 5 s after the cessation of any visually detectable movement of the ROPS.

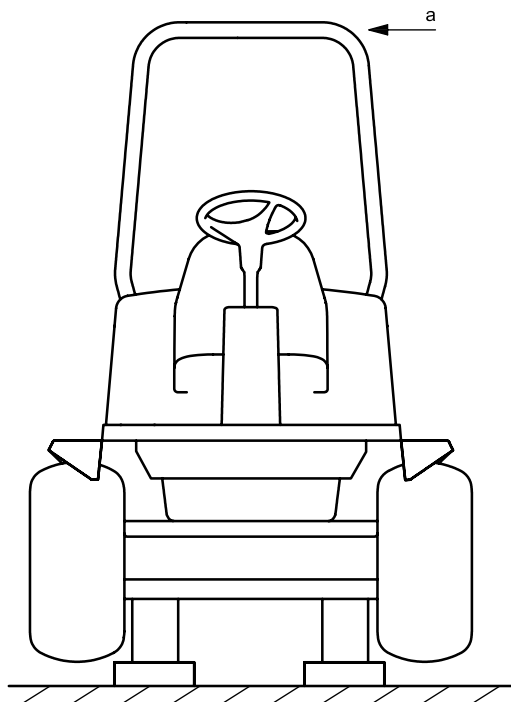

a Direction of side load.

Figure 4 — Side load

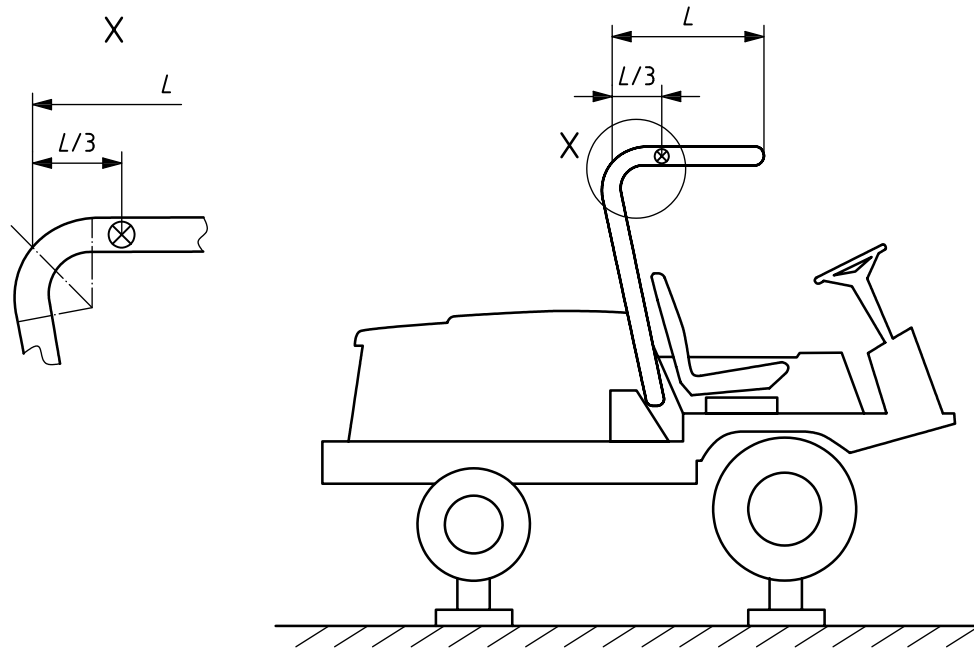
**Key**

L length of forward projection

Figure 5 — Location of side load with application point — ROPS with forward projection

6.3 Vertical crushing test

Position the beam across the uppermost structural members of the ROPS. For two-post ROPS with a forward projection, the load shall be applied one-third of the distance from the back of the ROPS to the front of the forward projection.

For a four-post ROPS, the manner of distributing this load shall be such as to best utilize those structural members in the fore and aft plane which will support the machine in an upset position. The crushing force or load shall be in the vertical direction and shall be in a vertical plane passing through the SIP and parallel to the longitudinal axis of the machine.

Apply a vertical crush load force, F_v , in newtons, of at least

$$F_v = 20 \cdot m_t.$$

Maintain this force for at least 5 s after the cessation of any visually detectable movement of the ROPS.

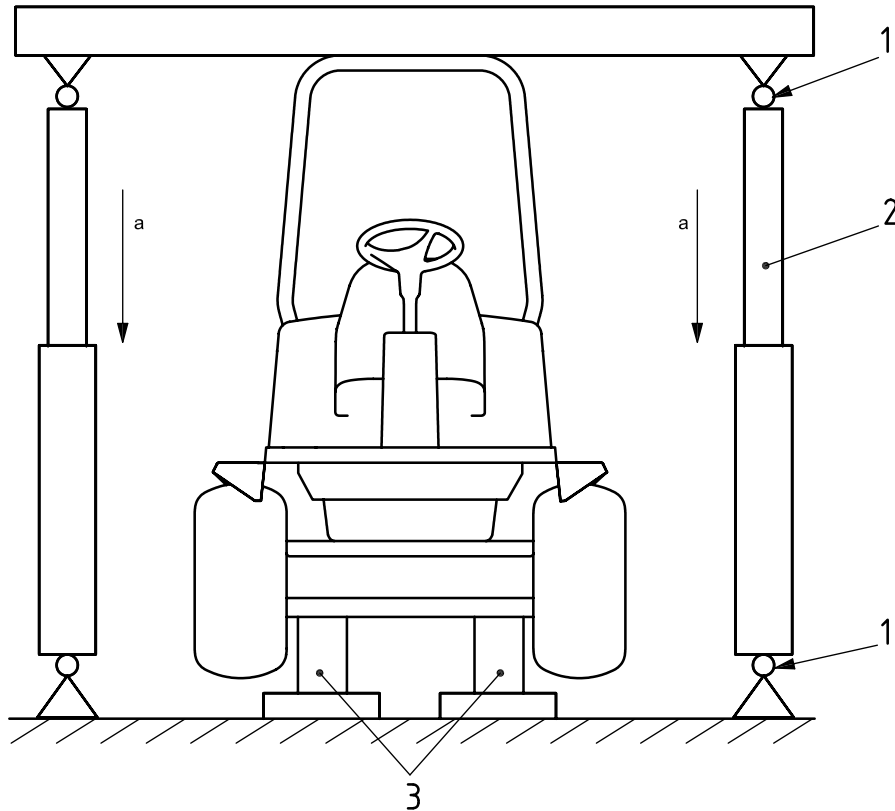

Key

- 1 universal pin joint
- 2 hydraulic cylinder
- 3 supports under front and rear axles
- a Direction of vertical crush load.

Figure 6 — Vertical crushing test

6.4 Observations during testing

During each test, an examination shall be made to ascertain whether any part of the ROPS has entered the DLV (deflection-limiting volume).

In addition, an examination shall be made to determine whether any part of the DLV is outside the protection of the ROPS, i.e. where any parts of the DLV come into contact with flat ground in the event of the machine overturning in the direction of loading. For this purpose, the smallest front and rear tyres, and the track width setting, as specified by the manufacturer, shall be considered.

See Clause 7.

7 Deflection-limiting volume (DLV)

The DLV is established using the SIP and is allowed to rotate forward, rearward and to each side about the SIP by not more than 15° from vertical. The upper portion of the DLV is allowed to flex forward and rearward an additional 15°, as illustrated in Figure 7.

The SIP could move during the test due to deflection of the chassis. If this occurs, the DLV shall continue to maintain its relationship with the SIP.

Dimensions in millimetres

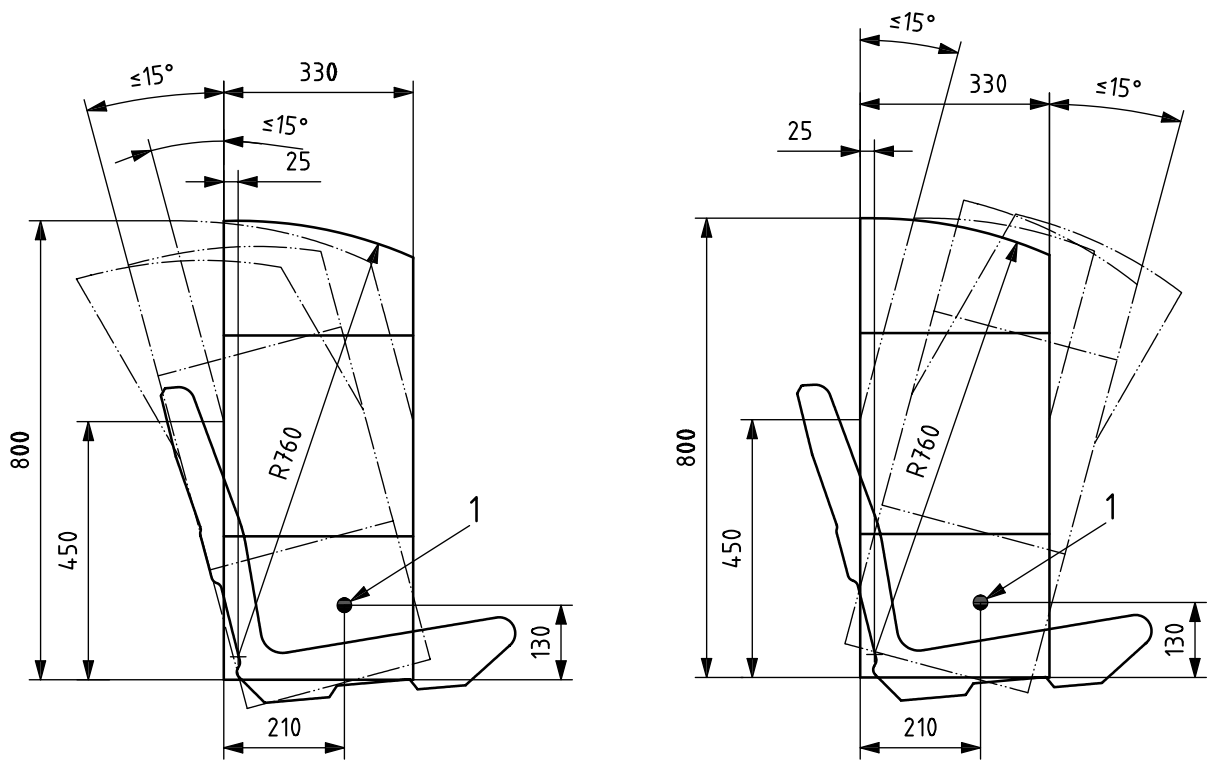

a) DLV side view in vertical and rearward positions

b) DLV side view in vertical and forwardmost positions

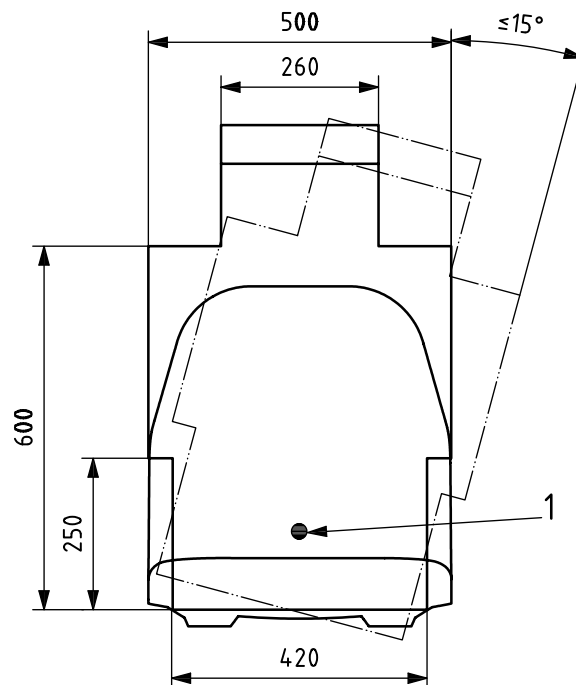

c) DLV front view in leftmost position (may also rotate similarly to the right)

Key

- 1 seat index point (SIP)

Figure 7 — Deflection-limiting volume (DLV)

8 Tolerances

Measurements made during the tests shall be to the following tolerances:

- a) time $\pm 0,2$ s;
- b) distance $\pm 0,5$ % of measured value;
- c) force $\pm 1,0$ % of measured value.

9 Acceptance conditions

9.1 General requirements

For the ROPS to be accepted, it shall fulfill the conditions specified in 9.2 to 9.5 during and after the tests. On articulated machines, the DLV shall remain protected at any angle of articulation of the machine when overturned.

9.2 Deflection-limiting volume/ground plane

No part shall enter the DLV as defined in Clause 7. Furthermore, the DLV shall not be outside the protection provided by the ROPS (3.6). For this purpose, the DLV shall be considered to be outside the ROPS protection if any part of the DLV would have come into contact with flat ground if the machine had overturned towards the direction from which the load was applied. To estimate this, the smallest front and rear tyres, and the track width setting, as specified by the manufacturer, shall be considered. The direction of the allowable rotation and flexing of the DLV is not dependent on the test loading direction. See Figure 8 for ground plane examples.

After each test, all structural members, joints and fastening systems shall be visually examined for fractures or cracks, while any small cracks in unimportant parts and any tears caused by the edges of the testing rig shall be ignored.

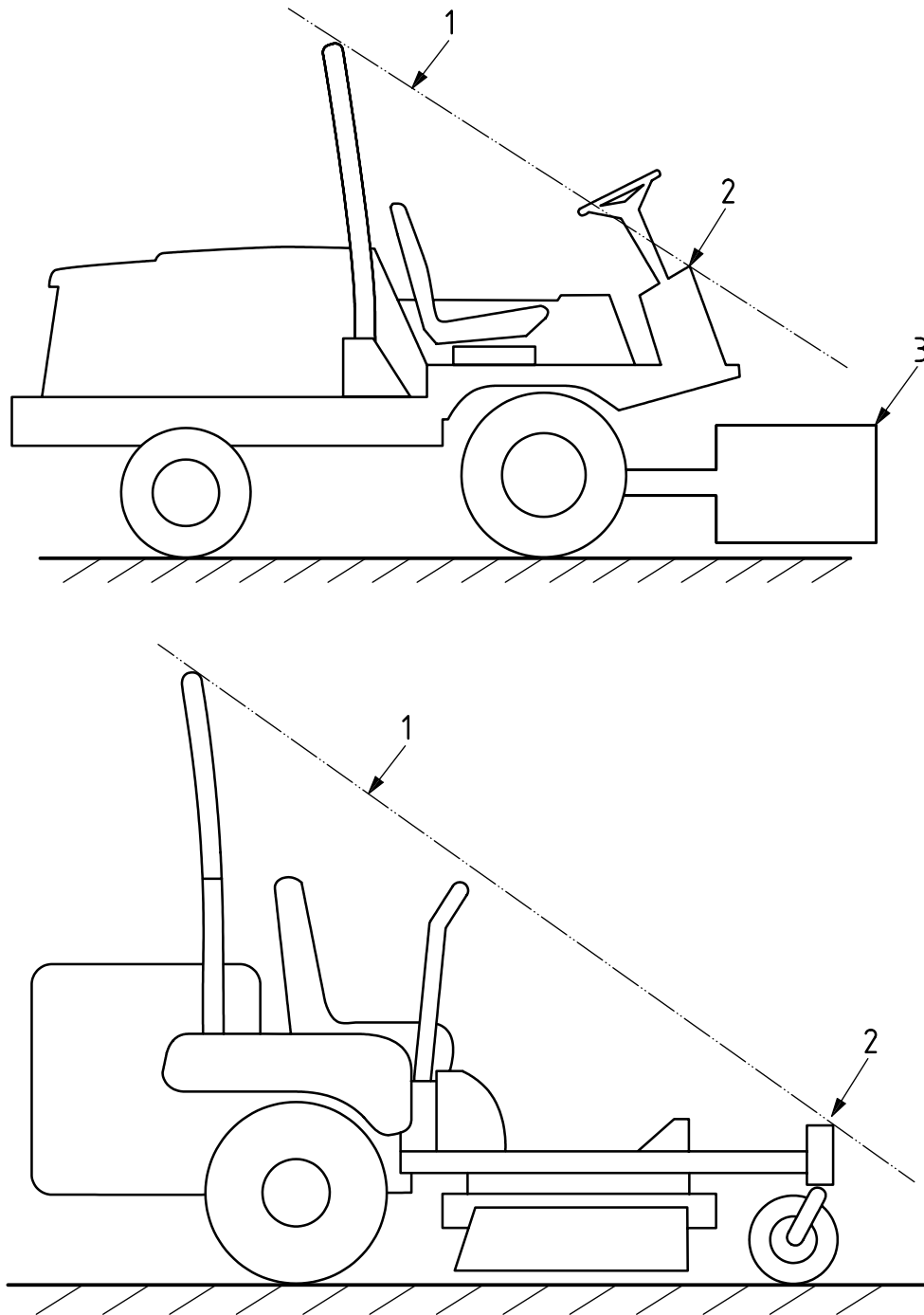
**Key**

- 1 ground plane
- 2 part of machine capable of supporting machine mass when overturned
- 3 attachment

Figure 8 — Examples of ground plane shown with deflected ROPS structure

9.3 Horizontal overload test for energy-absorbing ROPS

An overload test to determine the residual strength of the ROPS, after a horizontal loading test, shall be carried out if the force drops more than 3 % over the last 5 % of the deflection attained while absorbing the required energy (see Figures 9 and 10).

This test shall consist of continuing the horizontal loading in increments of 5 % of the original required energy up to a total of 20 % additional energy (see Figure 11), and shall be successfully completed providing:

- after the absorption of 5 %, 10 % or 15 % additional energy, the force drops by less than 3 % for each 5 % increment and is greater than $0,8 F_{max}$;
- after the absorption of 20 % additional energy, the force is greater than $0,8 F_{max}$.

Entry into the DLV or lack of protection of the DLV is permitted during this overload test. After removing the load, the structure shall not be in the DLV and shall protect the DLV.

There shall be no protruding member or component of the ROPS likely to cause serious injury during an overturning incident.

9.4 Vertical crush overload test

If cracks or tears that cannot be considered negligible appear during a vertical crush loading test, a second, similar vertical crush loading test, but with a force of $1,2 F_v$, shall be carried out immediately after the vertical crush loading test that caused the cracks or tears to appear.

9.5 Cold weather embrittlement

Cold weather embrittlement resistance shall be verified by either performing the tests given in Clause 6 at $-18\text{ }^\circ\text{C}$ or colder or by the methods given in Annex A.

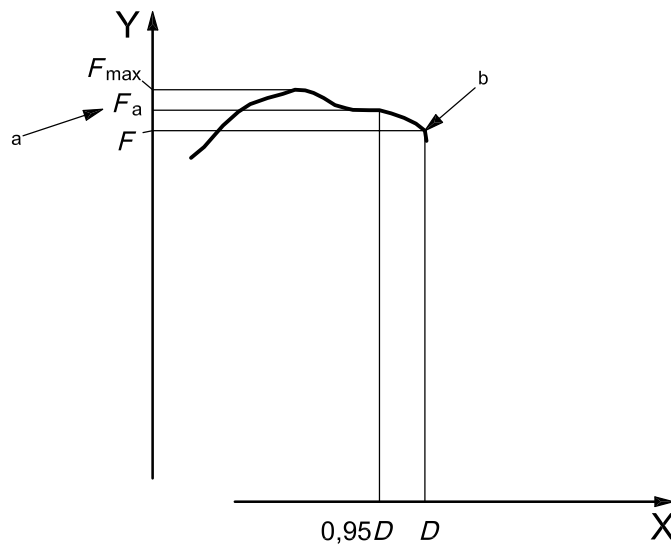

Key

- X deflection
- Y static load force

- a Locate F_a in relation to $0,95D$.
- b Overload test not necessary, as $F_a \leq 1,03F$.

Figure 9 — Static load force-deflection diagram — Overload test not necessary

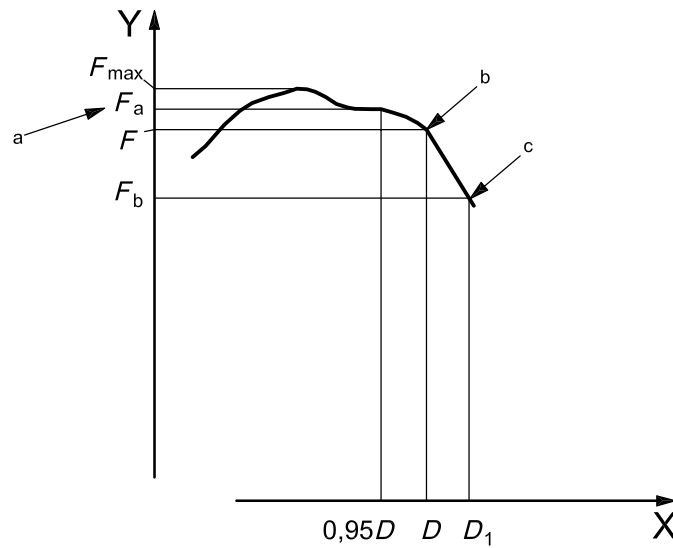

Key

- X deflection
- Y static load force
- a Locate F_a in relation to $0,95D$.
- b Overload test necessary, as $F_a > 1,03F$.
- c Overload test performance satisfactory, as $F_b > 0,97F$ and $F_b > 0,8F_{max}$.

Figure 10 — Static load force-deflection diagram — Overload test necessary

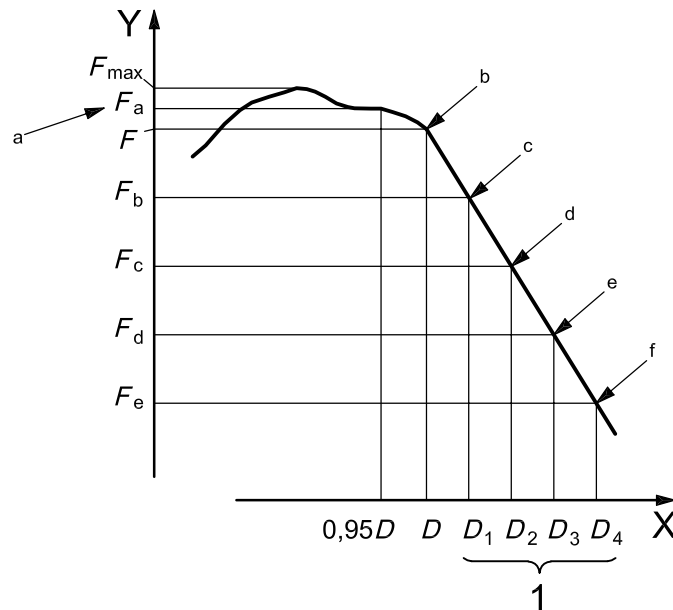

Key

- 1 overload
- X deflection
- Y static load force
- a Locate F_a in relation to $0,95D$.
- b Overload test necessary, as $F_a > 1,03F$.
- c $F_b < 0,97F$, further overload therefore necessary.
- d $F_c < 0,97F_b$, further overload therefore necessary.
- e $F_d < 0,97F_c$, further overload therefore necessary.
- f Overload test performance satisfactory if $F_e > 0,8F_{max}$. Failure occurs at any stage when load drops below $0,8F_{max}$.

Figure 11 — Static load force-deflection diagram — Continuing overload test

10 Extension to other machines

In the case of a ROPS that has fulfilled the conditions required for acceptance according to Clause 9, and which is designed to be used on other machine models, the test procedures specified in 6.2 need not be carried out on each machine model, provided that the ROPS and machine under test comply with the following conditions, and that the test report refers to the previous test report.

- a) The required energy shall not exceed the energy calculated for the original test by more than 5 %.
- b) The attachment method and the machine components to which the attachment is made shall be identical or of equivalent strength.
- c) Any components (e.g. mudguards, bonnet) that could provide support for the ROPS shall be identical, or judged to give at least the same support.
- d) The position and critical dimensions of the seat and the relative position of the machine's ROPS shall be such that the DLV shall remain within the protection of the deflected ROPS throughout all test procedures.

11 Labelling

A label shall be durable and permanently attached to the main ROPS so as to be easily read. It shall be protected from damage and contain at least the following information:

- a) name and address of the manufacturer;
- b) ROPS serial number (if the ROPS is standard equipment, this is not required);
- c) machine make, model(s) or series number(s) of the machine(s) the ROPS is designed to fit;
- d) reference mass, in kilograms;
- e) reference to this International Standard (i.e. "ISO 21299:2009"), stating conformance with its energy-absorbing or rigid ROPS requirements.

12 Test report

Data that may be included in a ROPS test report is set forth in Annex C.

Annex A (normative)

Requirements for providing resistance to brittle fracture of ROPS at reduced operating temperature

The following requirements and procedure are intended to provide strength and resistance to brittle fracture at reduced temperature. The following minimum material requirements shall be met when judging the roll-over protective structure's suitability at reduced operating temperature in those countries requiring this additional operating protection.

NOTE The requirements and procedure in A.3 and A.4 are set forth as information until suitable International Standards are developed.

A.1 Bolts and nuts used to attach the ROPS to the machine frame and to connect structural parts of the ROPS shall be property class 8.8, 9.8 or 10.9 for bolts (see ISO 898-1) and property class 8, 9 or 10 for nuts (see ISO 898-2).

A.2 All welding electrodes used in the fabrication of structural members and mounts shall be compatible with the ROPS material as given in A.3.

A.3 Steel materials for structural members of the roll-over protective structure shall be of controlled toughness material, exhibiting minimum Charpy V-notch impact energy requirements according to Table A.1. Structural members that can either be demonstrated to be in plane stress or that are subjected to sufficiently low strain rates such that the possibility of brittle fracture is precluded in the event of a low temperature field upset, need not comply with this requirement.

NOTE Steel with an as-rolled thickness of less than 2,5 mm and a carbon content of less than 0,2 % is considered to meet this requirement.

Structural members of the roll-over protective structure made from materials other than steel shall have equivalent low temperature impact resistance. Specimens shall be "longitudinal" and taken from flat stock, tubular or structural sections before forming or welding for use in the roll-over protective structure. Specimens from tubular or structural sections shall be taken from the middle of the biggest side and shall not include welds.

A.4 The Charpy V-notch tests shall be conducted in accordance with the procedure in ASTM A370 ²⁾, except that specimen sizes shall be in accordance with the dimensions given in Table A.1.

A.5 One alternative to this procedure is to use killed or semi-killed steel, for which a specification shall be provided.

2) The reference to ASTM A370 will be replaced as soon as a corresponding International Standard becomes available.

Table A.1 — Minimum Charpy V-notch energy requirements for ROPS material at specimen temperatures of –20 °C and –30 °C

Specimen size mm	Absorbed energy	
	–30 °C J	–20 °C J ^b
10 × 10 ^a	11	27,5
10 × 9	10	25
10 × 8	9,5	24
10 × 7,5 ^a	9,5	24
10 × 7	9	22,5
10 × 6,7	8,5	21
10 × 6	8	20
10 × 5 ^a	7,5	19
10 × 4	7	17,5
10 × 3,3	6	15
10 × 3	6	15
10 × 2,5 ^a	5,5	14

^a Indicates preferred size. Specimen size shall be no less than the largest preferred size that the material will permit.

^b The energy requirement at the temperature –20° C is 2,5 times the value specified for –30 °C. Other factors affect impact energy strength, i.e. direction of rolling, yield strength, grain orientation and welding. These factors shall be considered when selecting and using a particular type of steel.

Annex B (informative)

ROPS standards judged to provide operator protection comparable to this International Standard

This annex provides for information a list of standards which have been employed in the past to determine the performance of ROPS for powered ride-on turf care machinery and which have been judged to provide operator protection comparable to that specified in this International Standard.

ISO 3463:2006, *Tractors for agriculture and forestry — Roll-over protective structures (ROPS) — Dynamic test method and acceptance conditions*

ISO 3471:2008, *Earth-moving machinery — Roll-over protective structures — Laboratory tests and performance requirements*

ISO 5700:2006, *Tractors for agriculture and forestry — Roll-over protective structures — Static test method and acceptance conditions*

ISO 12003-1:2008, *Agricultural and forestry tractors — Narrow-track wheeled tractors — Part 1: Front-mounted roll-over protective structures*

ISO 12003-2:2008, *Agricultural and forestry tractors — Narrow-track wheeled tractors — Part 2: Rear-mounted roll-over protective structures*

AS 1636.1:1996, *Tractors — Roll-over protective structures — Criteria and tests — Conventional tractors*

ASAE S383.1:2004, *Roll-Over Protective Structures (ROPS) for Wheeled Agricultural Tractors*

ANSI/ASAE S478:2000, *Roll-Over Protective Structures (ROPS) for Compact Utility Tractors*

CSA B352.0-95, B352.1-95, B352.2-95, *Rollover Protective Structures (ROPS) for Agricultural, Construction, Earthmoving, Forestry, Industrial, and Mining Machines — Part 1: General Requirements, Part 2: Testing requirements for ROPS on Agricultural tractors, Part 3: Testing Requirements for ROPS on Construction, Earthmoving, Forestry, Industrial, and Mining Machines*

SAE J1040, *Performance Criteria for Roll-over Protective Structures (ROPS) for Construction, Earthmoving, Forestry, and Mining Machines*

SAE J1194:1999, *Rollover Protective Structures (ROPS) for Wheeled Agricultural Tractors*

SAE J2194:1997, *Roll-Over Protective Structures (ROPS) for Wheeled Agricultural Tractors*

OECD Code 4 - February 2007, *OECD standard code for the official testing of protective structures on agricultural and forestry tractors (static test)*

OECD Code 6 - February 2007, *OECD standard code for the official testing of front mounted roll-over protective structures on narrow-track wheeled agricultural and forestry tractors*

OECD Code 7 - February 2007, *OECD standard code for the official testing of rear mounted roll-over protective structures on narrow-track wheeled agricultural and forestry tractors*

OSHA 1928.51, 1928.52, 1928.53, *Roll-over protective structures (ROPS) for tractors used in agricultural operations, Protective frames for wheel-type agricultural tractors – test procedures and performance requirements, Protective enclosures for wheel-type agricultural tractors – test procedures and performance requirements (with the addition of a $20M_t$ in newtons, vertical crush load)*

Annex C (informative)

Test report for roll-over protective structure

The ROPS test report should be written in a manner that documents that key procedures were observed, and that minimum performance requirements were met. Report writers are encouraged to include photographic and/or video documentation, charts, graphs, drawings and narration. ROPS test documentation should include a statement of test data verification signed by the laboratory supervisor. Because there are several alternatives to meeting the compliance requirements of ISO 21299, the report author should structure the test report to reflect the requirements of the chosen physical test alternatives. The following is a list of data that may be included.

C.1 General

- Test date
- Name and address of the test laboratory
- Names and titles of personnel conducting the test
- Name and address of the machine manufacturer

C.2 Specification of the test machine

- Name and model of the machine that was tested
- ROPS/machine test mass (reference mass)
- Location of the SIP

C.3 Specification of the ROPS

- Name and address of the ROPS manufacturer
- ROPS model that was tested
- ROPS model or series identification
- Required force/energy calculations
- Rigid or energy-absorbing ROPS
- Photographs from various views showing mounting details and the protective structure
- Names and models of all the machines that the ROPS is intended to fit (in the event that a previously tested ROPS is applied to a machine model, the previous test report is referenced)

C.4 Test equipment and test documentation

- Description of load application devices
- Description of the laboratory instrumentation and calibration
- ROPS test temperature and description of how ROPS temperature/material options were met
- Test load sequence
- Load/deflection charts
- Applied force/energy results
- Photographs or video of the structure during loading and at maximum energy/load

Bibliography

- [1] EN 474-10:1998, *Earth-moving machinery — Safety — Part 10: Requirements for trenchers*
- [2] ISO 5395, *Power lawn-mowers, lawn tractors, lawn and garden tractors, professional mowers, and lawn and garden tractors with mowing attachments — Definitions, safety requirements and test procedures*
- [3] ISO 5700:2006, *Tractors for agriculture and forestry — Roll-over protective structures (ROPS) — Static test method and acceptance conditions*

.....

ICS 65.060.70

Price based on 22 pages