**Pneumatic fluid power — Cylinders —
Compact cylinders, 1 000 kPa (10 bar)
series, bores from 20 mm to 100 mm**

*Transmissions pneumatiques — Vérins — Vérins compacts, série
1 000 kPa (10 bar), alésages de 20 mm à 100 mm*



PDF disclaimer

This PDF file may contain embedded typefaces. In accordance with Adobe's licensing policy, this file may be printed or viewed but shall not be edited unless the typefaces which are embedded are licensed to and installed on the computer performing the editing. In downloading this file, parties accept therein the responsibility of not infringing Adobe's licensing policy. The ISO Central Secretariat accepts no liability in this area.

Adobe is a trademark of Adobe Systems Incorporated.

Details of the software products used to create this PDF file can be found in the General Info relative to the file; the PDF-creation parameters were optimized for printing. Every care has been taken to ensure that the file is suitable for use by ISO member bodies. In the unlikely event that a problem relating to it is found, please inform the Central Secretariat at the address given below.

© ISO 2004

All rights reserved. Unless otherwise specified, no part of this publication may be reproduced or utilized in any form or by any means, electronic or mechanical, including photocopying and microfilm, without permission in writing from either ISO at the address below or ISO's member body in the country of the requester.

ISO copyright office
Case postale 56 • CH-1211 Geneva 20
Tel. + 41 22 749 01 11
Fax + 41 22 749 09 47
E-mail copyright@iso.org
Web www.iso.org

Published in Switzerland

Foreword

ISO (the International Organization for Standardization) is a worldwide federation of national standards bodies (ISO member bodies). The work of preparing International Standards is normally carried out through ISO technical committees. Each member body interested in a subject for which a technical committee has been established has the right to be represented on that committee. International organizations, governmental and non-governmental, in liaison with ISO, also take part in the work. ISO collaborates closely with the International Electrotechnical Commission (IEC) on all matters of electrotechnical standardization.

International Standards are drafted in accordance with the rules given in the ISO/IEC Directives, Part 2.

The main task of technical committees is to prepare International Standards. Draft International Standards adopted by the technical committees are circulated to the member bodies for voting. Publication as an International Standard requires approval by at least 75 % of the member bodies casting a vote.

Attention is drawn to the possibility that some of the elements of this document may be the subject of patent rights. ISO shall not be held responsible for identifying any or all such patent rights.

ISO 21287 was prepared by Technical Committee ISO/TC 131, *Fluid power systems*, Subcommittee SC 3, *Cylinders*.

Introduction

In pneumatic fluid power systems, power is transmitted and controlled through a gas under pressure within a circuit.

One component of such system is the pneumatic cylinder. This is a device which converts power into linear force and motion. It consists of a movable element, i.e. a piston, and a piston rod, operating within a cylindrical bore.

The compact cylinder series without cushioning allows the application of pneumatic cylinders within systems where "normal" pneumatic cylinder series because of their mounting dimensions cannot be used.

.....

Pneumatic fluid power — Cylinders — Compact cylinders, 1 000 kPa (10 bar) series, bores from 20 mm to 100 mm

1 Scope

This International Standard establishes a metric series of single rod pneumatic compact cylinders with bores of 20 mm to 100 mm for use of at maximum working pressure of 1 000 kPa (10 bar¹⁾) with and without magnetic function.

This series of pneumatic cylinder is not equipped with adjustable cushioning. Therefore, the application is restricted to those systems where adjustable cushioning is not required.

Cylinders with bores of 20 mm and 25 mm can be used with end cover mountings in accordance with this International Standard. Cylinders with bores from 32 mm to 100 mm can be used with end cover mountings in accordance with ISO 15552. Piston rod mountings can be used for the different bores in accordance with ISO 8139 and ISO 8140.

2 Normative references

The following referenced documents are indispensable for the application of this document. For dated references, only the edition cited applies. For undated references, the latest edition of the referenced document (including any amendments) applies.

ISO 3320, *Fluid power systems and components — Cylinder bores and piston rod diameters — Metric series*

ISO 4393, *Fluid power systems and components — Cylinders — Basic series of piston strokes*

ISO 5598, *Fluid power systems and components — Vocabulary*

ISO 6099, *Fluid power systems and components — Cylinders — Identification code for mounting dimensions and mounting types*

ISO 8139, *Pneumatic fluid power — Cylinders, 1 000 kPa (10 bar) series — Rod end spherical eyes — Mounting dimensions*

ISO 8140, *Pneumatic fluid power — Cylinders 1 000 kPa (10 bar) — Rod end clevis — Mounting dimensions*

ISO 15552, *Pneumatic fluid power — Cylinders with detachable mountings, 1 000 kPa (10 bar) series, bores from 32 mm to 320 mm — Basic, mounting and accessories dimensions*

ISO 16030, *Pneumatic fluid power — Connections — Ports and stud ends*

3 Terms and definitions

For the purposes of this document, the terms and definitions given in ISO 5598 and the following apply.

1) 1 bar = 0,1 MPa = 10⁵ Pa; 1 Pa = 1 N/m²

4 Bore sizes

Cylinders with the following bore dimensions, *AL*, expressed in millimetres, are included in this series, in accordance with ISO 3320:

20 - 25 - 32 - 40 - 50 - 63 - 80 - 100

5 Nominal stroke

5.1 The nominal strokes shall be selected from the recommended values given in ISO 4393, as shown in Figure 1. The maximum stroke length should not exceed 500 mm.

5.2 The nominal stroke tolerances are given in Table 1.

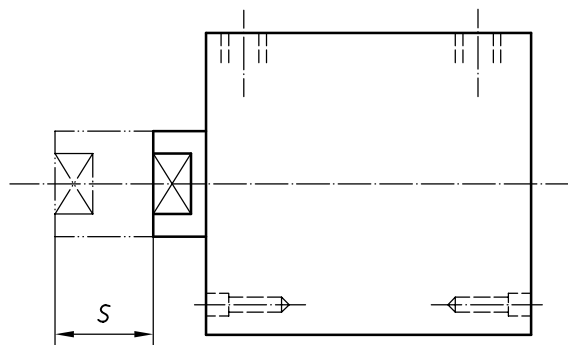

Figure 1 — Stroke, *S*

Table 1 — Nominal strokes tolerances

Dimensions in millimetres

Bore <i>AL</i>	Nominal stroke tolerance
20 25	+1,5 0
32 40 50	+2 0
63 80 100	+2,5 0

6 Dimensions

6.1 Cylinder basic dimensions shall conform to the requirements given in Figure 2 and Table 2.

6.2 Mounting dimensions shall conform to the requirements given in Figures 3 to 5 and Tables 3 to 5.

7 Mounting types

This standard includes the following mounting types in accord with ISO 6099:

- MP4: Cap, detachable plain eyes (see Figure 3 and Table 3);
- MF1: Head, rectangular flange (see Figure 4 and Table 4);
- MF2: Cap, rectangular flange (see Figure 4 and Table 4);
- MS1: End angles (see Figure 5 and Table 5).

8 Identification statement (reference to this International Standard)

Use the following statement in test reports, catalogues, and sales literature when electing to comply with this International Standard:

“Dimensions of pneumatic compact cylinder are in accordance with ISO 21287:2004, *Pneumatic fluid power — Cylinders — Compact cylinders, 1 000 kPa (10 bar) series, bores from 20 mm to 100 mm.*”

.....

Alternative: with male thread

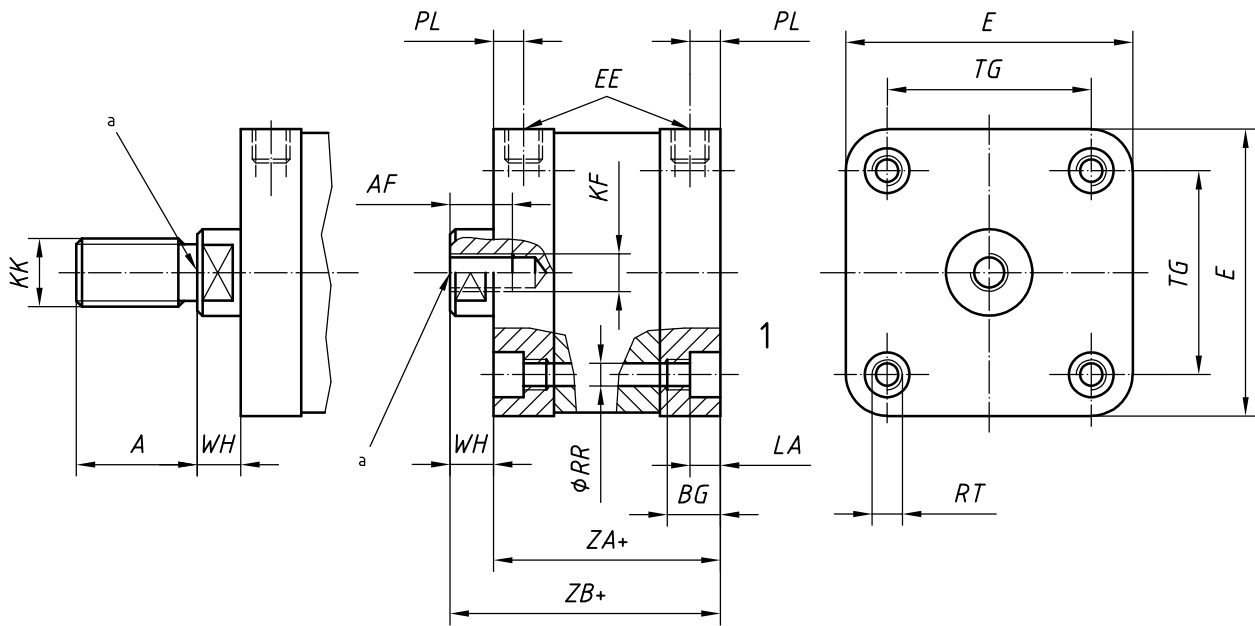

Key

- 1 drive for screw
- a TRP: Theoretical reference point according to ISO 6099.

Figure 2 — Basic dimensions

Table 2 — Basic dimensions

Dimensions in millimetres

Bore <i>AL</i>	<i>AF</i>	<i>A</i>	<i>WH</i>		<i>ZA</i>		<i>ZB^a</i>		<i>KF</i>	<i>KK</i>	<i>EE^b</i>	<i>BG</i>	<i>RR</i>	<i>TG</i>		<i>E</i>	<i>RT</i>	<i>LA</i>	<i>PL</i>
	min.	$\begin{matrix} 0 \\ -0,5 \end{matrix}$	nom.	tol.	nom.	tol.	nom.	tol.				min.	min.	nom.	tol.	max.		max.	min.
20	10	16	6	± 1,4	37	± 0,5	43	± 1,4	M6	M8 × 1,25	M5	15	4,1	22	± 0,4	38	M5	5	5
25	10	16	6	± 1,4	39	± 0,5	45	± 1,4	M6	M8 × 1,25	M5	15	4,1	26	± 0,4	41	M5	5	5
32	12	19	7	± 1,6	44	± 0,5	51	± 1,6	M8	M10 × 1,25	G1/8	16	5,1	32,5	± 0,5	50	M6	5	7,5
40	12	19	7	± 1,6	45	± 0,7	52	± 1,6	M8	M10 × 1,25	G1/8	16	5,1	38	± 0,5	58	M6	5	7,5
50	16	22	8	± 1,6	45	± 0,7	53	± 1,6	M10	M12 × 1,25	G1/8	16	6,4	46,5	± 0,6	70	M8	5	7,5
63	16	22	8	± 1,6	49	± 0,8	57	± 1,6	M10	M12 × 1,25	G1/8	16	6,4	56,5	± 0,7	80	M8	5	7,5
80	20	28	10	± 2,0	54	± 0,8	64	± 2,0	M12	M16 × 1,5	G1/8	17	8,4	72	± 0,7	96	M10	5	7,5
100	20	28	10	± 2,0	67	± 1,0	77	± 2,0	M12	M16 × 1,5	G1/8	17	8,4	89	± 0,7	116	M10	5	7,5

NOTE Dimensions *WH*, *ZA+* and *ZB+* are values for non-pressurised cylinders due to deformation of elastic buffers at stroke ends.

NOTE Nominal stroke $S \leq 500$.

^a Only for reference.

^b In accordance with ISO 16030.

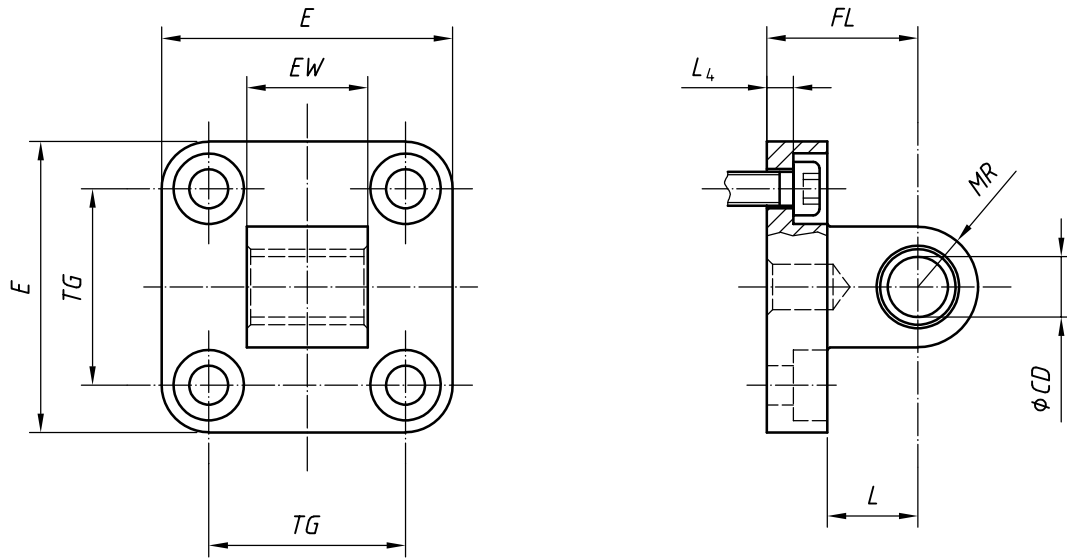

Figure 3 — Cap, detachable plain eyes (MP4)

Table 3 — Dimensions of cap, detachable plain eyes (MP4)

Dimensions in millimetres

Bore	<i>E</i>	<i>EW</i>	<i>TG</i>	<i>FL</i>	<i>L</i>	<i>L</i> ₄	<i>CD</i>	<i>MR</i>	Screw size	<i>XD</i>
<i>AL</i>	max.	-0,2 -0,6	± 0,2	± 0,2	min	+0,3 0	H9	max.		
20	38	16	22	20	12	3	8	9	M5 × 16	63
25	41	16	26	20	12	3	8	9	M5 × 16	65

a TRP

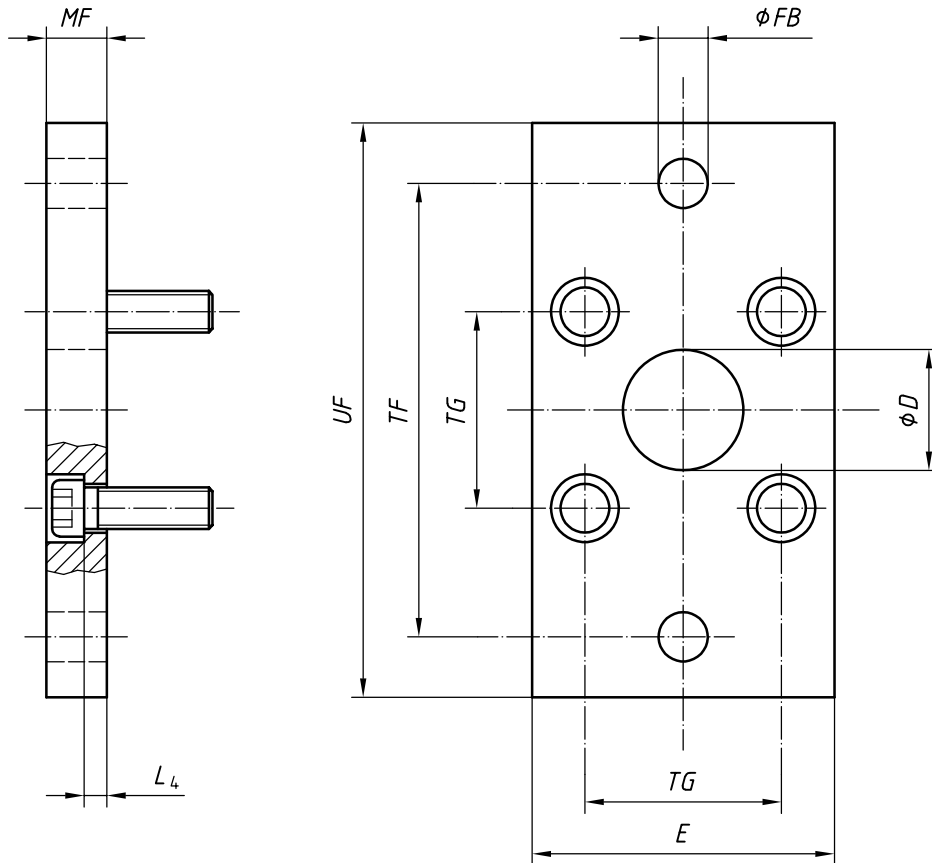
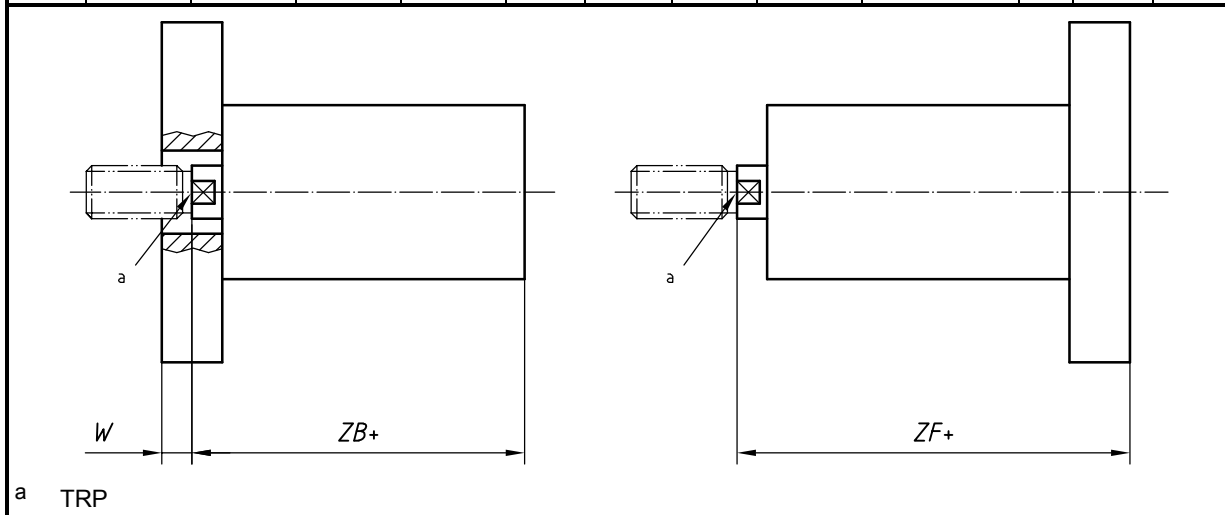

Figure 4 — Head, rectangular flange (MF1) and cap, rectangular flange (MF2)

Table 4 — Dimensions of head, rectangular flange (MF1) and cap, rectangular flange (MF2)

Dimensions in millimetres

Bore	<i>D</i>	<i>FB</i>	<i>TG</i>	<i>E</i>	<i>MF</i>	<i>TF</i>	<i>UF</i>	<i>L₄</i>	Screw size	<i>W</i>	<i>ZF</i>	<i>ZB</i>
<i>AL</i>	H11	H13	± 0,2	max.	js14	js13	max.	$\begin{matrix} 0 \\ -0,5 \end{matrix}$		ref.		
20	16	6,6	22	38	8	55	70	3	M5 × 16	2	51	43
25	16	6,6	26	41	8	60	76	3	M5 × 16	2	53	45



a TRP

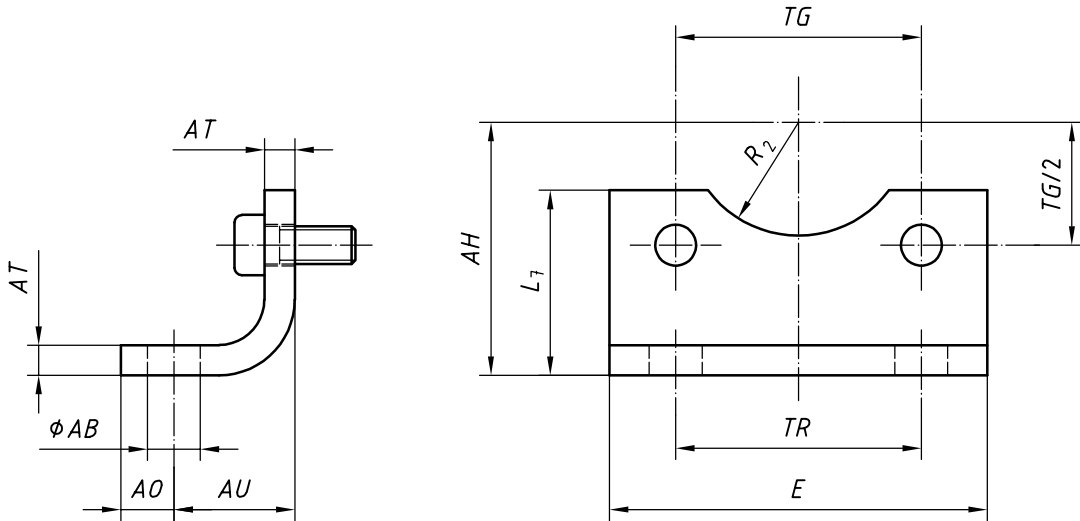
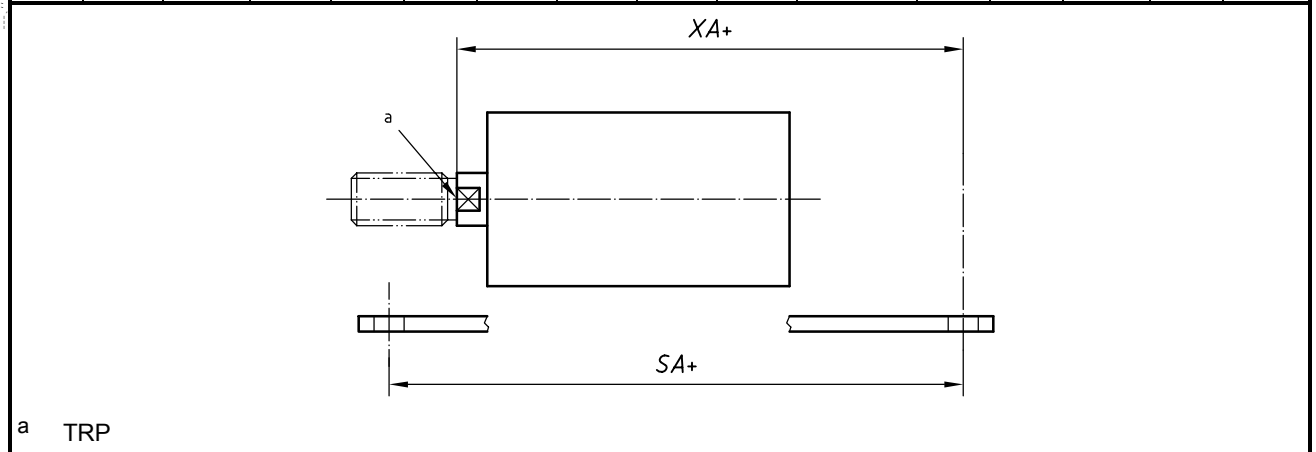

Figure 5 — End angles (MS1)

Table 5 — Dimensions of end angles (MS1)

Dimensions in millimetres

Bore	AL	AB	TG	E	TR	AO	AU	AH	L ₇	AT	Screw size	R ₂	SA		XA	
													nom.	tol.	nom.	tol.
20	7	7	22	38	22	7	16	27	22	4	M5 × 16	—	69		59	
25	7	7	26	41	26	7	16	29	22	4	M5 × 16	—	71		61	
32	7	7	32,5	50	32	7	16	33,5	24,5	4	M6 × 16	15	76	± 1,25	67	± 1,25
40	10	10	38	58	36	9	18	38	26	4	M6 × 16	17,5	81		70	
50	10	10	46,5	70	45	9	21	45	31	5	M8 × 20	20	87		74	
63	10	10	56,5	80	50	9	21	50	31	5	M8 × 20	22,5	91		78	
80	12	12	72	96	63	11	26	63	40,5	6	M10 × 20	22,5	106	± 1,6	90	± 1,6
100	14,5	14,5	89	116	75	13	27	74	47	6	M10 × 20	27,5	121		104	



ICS 23.100.20

Price based on 7 pages