

---

---

**Equipment for crop protection —  
Induction hoppers —**

**Part 1:  
Test methods**

*Matériel de protection des cultures — Incorporateurs —  
Partie 1: Méthodes d'essai*



Reference number  
ISO 21278-1:2008(E)

© ISO 2008

**PDF disclaimer**

This PDF file may contain embedded typefaces. In accordance with Adobe's licensing policy, this file may be printed or viewed but shall not be edited unless the typefaces which are embedded are licensed to and installed on the computer performing the editing. In downloading this file, parties accept therein the responsibility of not infringing Adobe's licensing policy. The ISO Central Secretariat accepts no liability in this area.

Adobe is a trademark of Adobe Systems Incorporated.

Details of the software products used to create this PDF file can be found in the General Info relative to the file; the PDF-creation parameters were optimized for printing. Every care has been taken to ensure that the file is suitable for use by ISO member bodies. In the unlikely event that a problem relating to it is found, please inform the Central Secretariat at the address given below.



**COPYRIGHT PROTECTED DOCUMENT**

© ISO 2008

All rights reserved. Unless otherwise specified, no part of this publication may be reproduced or utilized in any form or by any means, electronic or mechanical, including photocopying and microfilm, without permission in writing from either ISO at the address below or ISO's member body in the country of the requester.

ISO copyright office  
Case postale 56 • CH-1211 Geneva 20  
Tel. + 41 22 749 01 11  
Fax + 41 22 749 09 47  
E-mail [copyright@iso.org](mailto:copyright@iso.org)  
Web [www.iso.org](http://www.iso.org)

Published in Switzerland

# Contents

Page

Foreword.....	iv
Introduction .....	v
1 Scope .....	1
2 Normative references .....	1
3 Terms and definitions.....	1
4 Test materials and equipment .....	2
5 Test conditions .....	2
5.1 General.....	2
5.2 Environmental conditions.....	2
5.3 Liquid pressure .....	3
5.4 Volumetric and flow-rate measurement .....	3
5.5 Weight measurement.....	3
6 Test methods.....	3
6.1 Nominal volume of the induction hopper.....	3
6.2 Total volume of the induction hopper .....	3
6.3 Precision of the level indicator.....	4
6.4 Emptying flow rate.....	4
6.5 Emptying performance with powder.....	5
6.6 Emptying performance with micro-granular product .....	6
6.7 Efficiency of the induction hopper internal washing system.....	6
6.8 Cleaning device for crop protection product cans .....	7
6.9 Evaluation of hydraulic tightness .....	9
7 Test report .....	10
Annex A (normative) Micro-granular test material .....	11
Annex B (normative) Sticky reference product.....	12
Annex C (informative) Example test report.....	13
Bibliography .....	14

© ISO 2008. All rights reserved.

## Foreword

ISO (the International Organization for Standardization) is a worldwide federation of national standards bodies (ISO member bodies). The work of preparing International Standards is normally carried out through ISO technical committees. Each member body interested in a subject for which a technical committee has been established has the right to be represented on that committee. International organizations, governmental and non-governmental, in liaison with ISO, also take part in the work. ISO collaborates closely with the International Electrotechnical Commission (IEC) on all matters of electrotechnical standardization.

International Standards are drafted in accordance with the rules given in the ISO/IEC Directives, Part 2.

The main task of technical committees is to prepare International Standards. Draft International Standards adopted by the technical committees are circulated to the member bodies for voting. Publication as an International Standard requires approval by at least 75 % of the member bodies casting a vote.

Attention is drawn to the possibility that some of the elements of this document may be the subject of patent rights. ISO shall not be held responsible for identifying any or all such patent rights.

ISO 21278-1 was prepared by Technical Committee ISO/TC 23, *Tractors and machinery for agriculture and forestry*, Subcommittee SC 6, *Equipment for crop protection*.

ISO 21278 consists of the following parts, under the general title *Equipment for crop protection — Induction hoppers*:

- *Part 1: Test methods*
- *Part 2: General requirements and performance limits*

## Introduction

The sprayer main tank may be connected to an introduction hopper in order to prevent chemical cross-contamination, contamination of the operator and of the environment.

Currently two main different types of hopper are available on the market:

- introduction hoppers, which are able to transfer the chemical into the main tank of the sprayer;
- induction hoppers, which are able to transfer the chemical product into the sprayer and partially mix the chemical product, and are able to carry out self-cleaning.

ISO 21278 is applicable to induction hoppers for fertilizers and plant protection products for agricultural crop protection machines and is aimed at verifying their functionality.

Copyright International Organization for Standardization

# Equipment for crop protection — Induction hoppers —

## Part 1: Test methods

### 1 Scope

This part of ISO 21278 specifies the test methods for the verification of the performance limits of induction hoppers, as specified in ISO 21278-2.

### 2 Normative references

The following referenced documents are indispensable for the application of this document. For dated references, only the edition cited applies. For undated references, the latest edition of the referenced document (including any amendments) applies.

ISO 5681, *Equipment for crop protection — Vocabulary*

ISO 5682-2:1997, *Equipment for crop protection — Spraying equipment — Part 2: Test methods for hydraulic sprayers*

ISO 21278-2, *Equipment for crop protection — Induction hoppers — Part 2: General requirements and performance limits*

### 3 Terms and definitions

For the purposes of this document, the terms and definitions given in ISO 5681 and the following apply.

#### 3.1

##### **induction hopper**

device having a bowl able to transfer and partially mix any kind of liquid or solid plant protection products or fertilizers inside the main tank of the sprayer, and able to self-clean

NOTE The device may be attached to the machine or free-standing, and able to be connected to the sprayer tank only for filling operations.

#### 3.2

##### **cleaning device for crop protection product cans**

device for cleaning the inside of empty crop protection product cans

## 4 Test materials and equipment

- 4.1 **Clean water**, without any solids in suspension.
- 4.2 **Solution of water with coloured material**, for its visual determination.
- 4.3 **Copper oxychloride powder**, as defined in Annex A of ISO 5682-2:1997.
- 4.4 **Micro-granules**, as specified in Annex A.
- 4.5 **Sticky reference product**, (as specified in Annex B).
- 4.6 **Loading device**, having an outlet internal diameter of between 30 mm and 40 mm, see Figure 1.

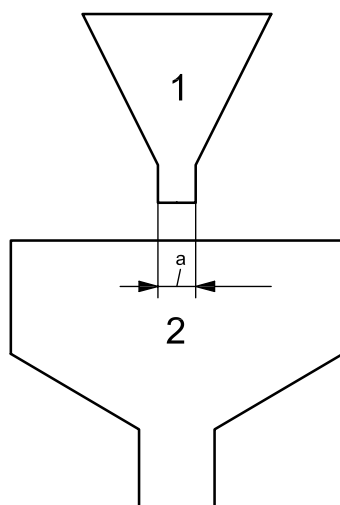

### Key

- 1 loading device (e.g. funnel)
- 2 induction hopper to be tested
- a Outlet diameter of the loading device.

**Figure 1 — Scheme of the positioning of the loading device to load the powder or micro-granules into the induction hopper**

## 5 Test conditions

### 5.1 General

The induction hopper shall be tested following the manufacturer's instructions as given in the instruction handbook and according to the nominal operating values declared by the manufacturer.

### 5.2 Environmental conditions

The water temperature shall be between 5 °C and 25 °C.

The environmental temperature, the test liquid temperature, the relative humidity and the atmospheric pressure shall be recorded in the test report.



### 5.3 Liquid pressure

The liquid pressure shall be measured with a maximum error  $\pm 2,5\%$ ; during the single test the working pressure may vary within  $\pm 5,0\%$  of the average value.

### 5.4 Volumetric and flow-rate measurement

The volumetric and flow-rate measurements shall be within  $\pm 1,0\%$  error.

### 5.5 Weight measurement

The weight measurement for introduced materials shall be within  $\pm 10$  g error.

## 6 Test methods

### 6.1 Nominal volume of the induction hopper

#### 6.1.1 Test procedure

Use the liquid as defined in 4.1.

Place the induction hopper in the position recommended by the manufacturer, and then fill the bowl up to the maximum filling level as defined in the instruction handbook.

#### 6.1.2 Results

Measure the amount of test liquid inside the bowl. The test results shall be expressed in litres (l).

### 6.2 Total volume of the induction hopper

#### 6.2.1 Test procedure

Use the liquid as defined in 4.1.

Place the induction hopper in the position recommended by the manufacturer.

If present, the cover is to be open during operation. Continue to fill the bowl up to its upper edge.

#### 6.2.2 Results

Measure the amount of test liquid inside the bowl. Results shall be reported in litres (l).

The percentage gap ( $V_{\text{over}}$ ) between nominal volume ( $V_{\text{nom}}$ ) and total volume ( $V_{\text{total}}$ ) of the induction hopper shall be calculated as follows:

$$V_{\text{over}} = \frac{(V_{\text{total}} - V_{\text{nom}}) \times 100}{V_{\text{nom}}}$$

### 6.3 Precision of the level indicator

#### 6.3.1 Test procedure

Use the liquid as defined in 4.1.

Place the empty induction hopper in the position recommended by the manufacturer and then:

- a) fill the bowl up to the first reading point of the filling level as defined in the instruction handbook and determine the amount of water introduced ( $X_{\text{meas}}$ );
- b) continue with the procedure as given in 6.3.1 a) for all the successive reading points.

#### 6.3.2 Results

The test results shall be expressed as percentages of nominal value ( $X_{\text{nom}}$ ).

The accuracy shall be calculated as follows:

$$\text{Accuracy} = \frac{(X_{\text{meas}} - X_{\text{nom}}) \times 100}{X_{\text{nom}}}$$

### 6.4 Emptying flow rate

#### 6.4.1 Test procedure

Use the liquid as defined in 4.1.

The emptying flow rate shall be determined measuring the time needed for a known amount of clean water to exit from the induction hopper bowl. The tests shall be made with the following operational parameters:

- a) inlet flow rate (pump flow rate): maximum and minimum values declared by the manufacturer; in addition flow rates at two intermediate points should be measured, if applicable;
- b) outlet pressure: at least with the maximum value declared by the manufacturer and 20 kPa. The outlet pressure shall be measured on the induction hopper pipe outlet after the suction device at a distance equal to 10 times the pipeline mean internal diameter, at the same height of the outlet (see Figure 2);
- c) outlet pipeline internal diameter: value declared by the manufacturer.

Operate with the induction hopper in stable conditions.

Make at least three replications of the test. The difference between the data of the three replications shall not exceed a coefficient of variation value of 10 %.

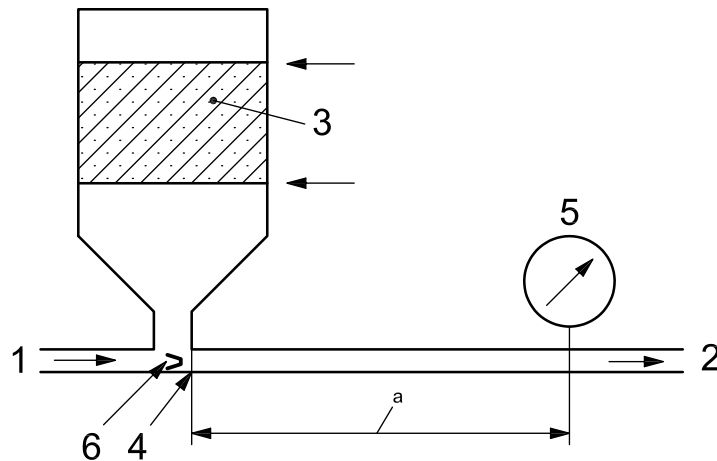

### Key

- 1 induction hopper pipe inlet
- 2 induction hopper pipe outlet
- 3 known volume of water (e.g. 10 l)
- 4 beginning of the induction hopper pipe outlet and measuring point of the induction hopper pipe outlet diameter
- 5 pressure gauge for the measurement of the outlet pressure
- 6 injector position

<sup>a</sup> Distance between the outlet pressure measuring point and the beginning of the induction hopper pipe outlet (equal to 10 times the induction hopper pipe outlet diameter).

**Figure 2 — Scheme of the outlet pressure measurement**

### 6.4.2 Results

The results shall be given in l/min from the outlet of the induction hopper according to the pump flow rate and according to the outlet pressure.

## 6.5 Emptying performance with powder

### 6.5.1 General

The emptying performance with powders shall be determined measuring the amount of powder residue in the induction hopper bowl after the test.

### 6.5.2 Test procedure

Use the test material as defined in 4.3 and apply the following procedure.

- a) Operate the induction hopper following the manufacturer's instructions as given in the instruction handbook and according to the nominal operating values declared by the manufacturer. Then, introduce 0,1 kg of the test material per 1 l of its nominal capacity with a continuous flow. To ensure continuity, a loading device as given in 4.6 shall be positioned as recommended by the manufacturer.
- b) Operate the system for a time of 60 s.

The outlet pressure during the test shall be at least the maximum pressure as defined by the manufacturer.

- c) Remove the residual test material from the induction hopper bowl, including cover (if present), using a known amount of water and collect it in a separate tank.
- d) Take at least three representative samples  $\geq 50$  ml from the homogenous volume of rinsing liquid.
- e) The samples shall be analysed by a drying technique at a temperature of between 105 °C and 110 °C. Another technique, giving equivalent values and accuracy, can be used. Measure the weight of the test material residues with the accuracy as defined in 5.5.
- f) Calculate the total amount of the test material residue in the induction hopper bowl and report the average value, in grams (g), and as a percentage of the amount originally introduced. The values obtained from three samples shall not be higher than  $\pm 10$  % of the mean value.

## 6.6 Emptying performance with micro-granular product

### 6.6.1 General

The emptying performance with micro-granules products shall be determined measuring the amount of micro-granules residue in the induction hopper bowl after the test.

### 6.6.2 Test procedure

Use test material as defined in 4.4 and apply the following procedure.

- a) Operate the induction hopper following the manufacturer's instructions as given in the instruction handbook and according to the nominal operating values declared by the manufacturer. Then introduce 0,1 kg of the test material per 1 l of its nominal capacity with a continuous flow. To ensure continuity, a loading device as given in 4.6 shall be positioned as recommended by the manufacturer.
- b) Operate the system for a time of 60 s.  
  
The outlet pressure during the test shall be at least the maximum pressure as defined by the manufacturer.
- c) Take at least three representative samples  $\geq 50$  ml from the homogenous volume of rinsing liquid.
- d) The samples shall be analysed by a drying technique at a temperature between 105 °C and 110 °C. Another technique, giving equivalent values and accuracy, can be used. Measure the weight of the test material residues with the accuracy defined in 5.5.
- e) Calculate the total amount of the test material residue in the induction hopper bowl and report the average value, in grams (g), and as a percentage of the amount originally introduced. The values obtained from three samples shall not be higher than  $\pm 10$  % of the mean value.

## 6.7 Efficiency of the induction hopper internal washing system

### 6.7.1 General

The efficiency of the induction hopper internal washing system shall be determined measuring the amount of test material residue in the induction hopper bowl after the test.

### 6.7.2 Test procedure

Use the test material as defined in 4.5 and apply the following procedure.

- a) Contaminate the dry induction hopper bowl with the test material to 5 % more than the nominal volume.
- b) With the system disconnected, open the discharge valve and empty by gravity the induction hopper bowl until no evident dripping is present for at least 20 s.
- c) Directly afterwards, reconnect the system, activate and operate the washing system:
  - use the liquid as defined in 4.1;
  - operate the washing system according to the nominated operating values declared by the manufacturer;
  - operate the washing system during the time specified in the instruction handbook, but for a maximum time of 2 min, and record the time.
- d) Clean with water accurately all internal parts of the induction hopper bowl including the cover (for example with a spray gun at low pressure) to collect all the test material remaining in the bowl.
- e) Measure the amount of water used for cleaning.
- f) Measure the amount of test material in the cleaning liquid by means of spectrophotometric analysis, fluorometric analysis or equivalent means.

### 6.7.3 Results

The test results shall be expressed as percentage value referred to the induction hopper nominal volume and as total quantity (ml).

## 6.8 Cleaning device for crop protection product cans

### 6.8.1 Test procedure

The test shall be carried out with a reference can as specified in 6.8.2 and a reference product as specified in 4.5, and apply the following procedure.

- a) Empty the reference can filled with the reference product until no evident dripping is present for at least 20 s and conduct the test directly.
- b) Clean the device to be tested according to the instruction handbook. The cleaning duration shall be a maximum of 30 s.
- c) Determine the residue of the reference product in the reference can after the cleaning procedure using simple methods of analysis (for example photometry or titration).

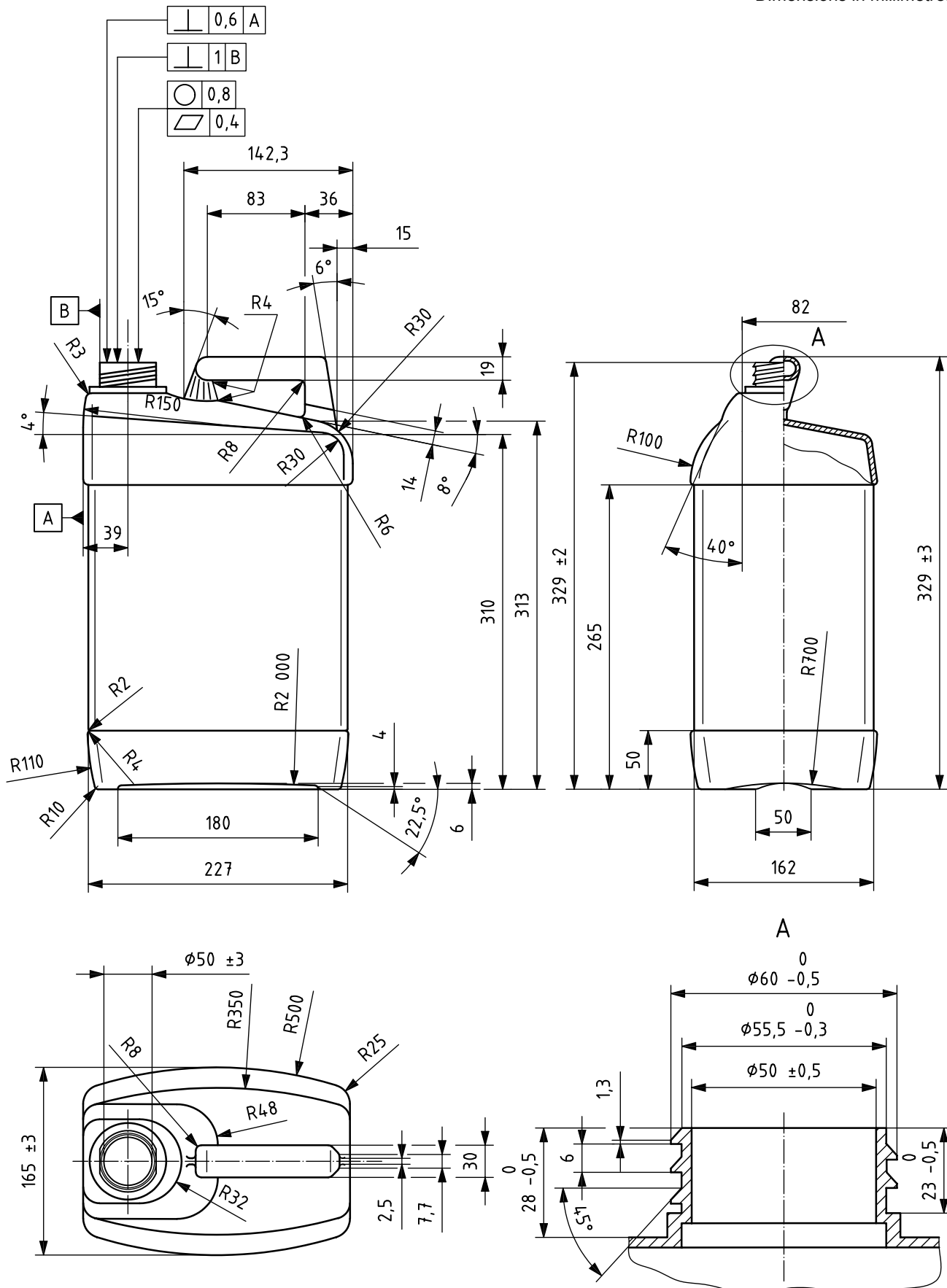

Figure 3 — Reference can

### 6.8.2 Reference can

The reference can shall have a nominal volume of 10 l and shall correspond to Figure 3. The handle shall be squeezed off.

In addition, it shall have the following characteristics:

- material: polyethylene, non coloured;
- weight: 400 g  $\pm$  20 g;
- maximum volume: 11 l  $\pm$  0,2 l (at 20 °C).

The reference can shall be stable on even ground. It shall be free from dirt.

### 6.8.3 Results

The volume of residue after cleaning shall be expressed in terms of a percentage of the nominal volume of the can.

## 6.9 Evaluation of hydraulic tightness

### 6.9.1 General

The efficiency of the hydraulic tightness shall be determined by visual evaluation of the splashes out of the induction hopper during:

- a) emptying of the hopper;
- b) internal cleaning of the hopper;
- c) cleaning of the can.

### 6.9.2 Test procedure

Use the test material as defined in 4.2.

Use the maximum inlet flow rate declared by the manufacturer.

For each test follow the instruction handbook.

#### 6.9.2.1 Emptying the hopper

Fill the hopper to its nominal level.

If present, open the cover, then activate the necessary function. Maintain the function activated until the hopper is empty. Evaluate the presence or absence of splashes.

NOTE In order to better understand the presence of splashes, use an absorbent sheet able to collect all the splashes.

#### 6.9.2.2 Internal cleaning of the hopper

Activate the necessary function according to the instruction handbook. Maintain the function activated for 60 s. Evaluate the presence or absence of splashes.

NOTE In order to better understand the presence of splashes, use an absorbent sheet able to collect all the splashes.

### **6.9.2.3 Cleaning the can**

Use a 10 l reference can.

Activate the necessary function according to the instruction handbook. Maintain the function activated for 30 s. Evaluate the presence or absence of splashes.

NOTE In order to better understand the presence of splashes, use an absorbent sheet able to collect all the splashes.

### **6.9.3 Results**

The result shall be expressed in terms of the presence or absence of splashes.

## **7 Test report**

The results of the tests shall be stated in a test report (see Annex C for example).



## Annex A (normative)

### Micro-granular test material<sup>1)</sup>

The micro-granular test material shall have the following characteristics.

- |                          |                                   |
|--------------------------|-----------------------------------|
| a) Composition           | Sulfur > 80 %.                    |
| b) Size of the particles | < 75 µm in 95,0 %.                |
| c) Solubility            | Water soluble at 25 °C.           |
| d) Bulk density          | (0,9 to 1,0) kg/dm <sup>3</sup> . |

NOTE Further selection of test products is in progress.

---

1) This test granule is also known under the trade name of Kumulus® Tecno. This information is given for the convenience of the users of this part of ISO 21278 and does not constitute an endorsement by ISO of this product.

## Annex B (normative)

### Sticky reference product

#### B.1 Composition

See Table B.1.

**Table B.1 — Composition of the sticky reference product referred to 100 g**

Constituent	Mass g
Polysaccharide (based on xanthan) <sup>2)</sup>	0,7
Methyl cellulose <sup>2)</sup>	0,3
Soda	0,2
Bacterial means of preservation <sup>2)</sup>	0,1
Duasyn blue acid	0,1
Water	98,6

#### B.2 Preparation of the sticky reference product

For the production of this solution the water is to be put in and after that, while mixing, the methyl cellulose dose wise and uninterrupted. During the mixing up to the complete solution of the methyl cellulose (about 30 min to 45 min) the preservative is to be added.

After that the polysaccharide in small doses is to be added during continued mixing so that no clots can develop. The further mixing time amounts to about 30 min. Then, soda is to be added dose wise and after its complete solution, the water soluble dye.

NOTE Further selection of test products is in progress.

---

<sup>2)</sup> Rhodopol 23 (polysaccharide), Tylose H 300 (methyl cellulose) and Kobate C (bacterial means of preservation) are examples of suitable products available commercially. This information is given for the convenience of users of this part of ISO 21278 and does not constitute an endorsement by ISO of these products.

## Annex C (informative)

### Example test report

Information to be reported includes:

- a) air temperature, water temperature, sticky product temperature, relative humidity, atmospheric pressure;
- b) nominal volume of the induction hopper;
- c) total volume of the induction hopper;
- d) precision of the level indicator;
- e) emptying flow rate;
- f) emptying performance with powders loading the product into the hopper;
- g) emptying performance with micro-granules loading the product into the hopper;
- h) efficiency of the induction hopper internal washing system;
- i) cleaning device for crop protection product cans;
- j) evaluation of hydraulic tight.

## Bibliography

- [1] ISO 22368-1, *Crop protection equipment — Test methods for the evaluation of cleaning systems — Part 1: Internal cleaning of complete sprayers*
- [2] ISO 22368-2, *Crop protection equipment — Test methods for the evaluation of cleaning systems — Part 2: External cleaning of sprayers*

.....

Copyright International Organization for Standardization

---

---

**ICS 65.060.40**

Price based on 14 pages