**Road vehicles — Test of braking systems
on vehicles with a maximum authorized
total mass of over 3,5 t using a roller
brake tester —**

Part 2:

**Air over hydraulic and purely hydraulic
braking systems**

*Véhicules routiers — Essai des systèmes de freinage des véhicules
ayant une masse totale maximale autorisée supérieure à 3,5 t effectué
sur banc d'essai de freinage à rouleaux —*

*Partie 2: Systèmes de freinage hydropneumatique et purement
hydraulique*



PDF disclaimer

This PDF file may contain embedded typefaces. In accordance with Adobe's licensing policy, this file may be printed or viewed but shall not be edited unless the typefaces which are embedded are licensed to and installed on the computer performing the editing. In downloading this file, parties accept therein the responsibility of not infringing Adobe's licensing policy. The ISO Central Secretariat accepts no liability in this area.

Adobe is a trademark of Adobe Systems Incorporated.

Details of the software products used to create this PDF file can be found in the General Info relative to the file; the PDF-creation parameters were optimized for printing. Every care has been taken to ensure that the file is suitable for use by ISO member bodies. In the unlikely event that a problem relating to it is found, please inform the Central Secretariat at the address given below.



COPYRIGHT PROTECTED DOCUMENT

© ISO 2008

All rights reserved. Unless otherwise specified, no part of this publication may be reproduced or utilized in any form or by any means, electronic or mechanical, including photocopying and microfilm, without permission in writing from either ISO at the address below or ISO's member body in the country of the requester.

ISO copyright office
Case postale 56 • CH-1211 Geneva 20
Tel. + 41 22 749 01 11
Fax + 41 22 749 09 47
E-mail copyright@iso.org
Web www.iso.org

Published in Switzerland

Licensed to /HAMID REZA AZIMI
ISO Store order #:923642/Downloaded:2008-06-24
Single user licence only, copying and networking prohibited

Contents

Page

Foreword	iv
Introduction	v
1 Scope	1
2 Terms and definitions	1
3 Symbols	2
4 Test conditions and evaluations	3
4.1 General	3
4.2 Preparation of vehicle and roller brake tester	3
4.3 Calculation and evaluation of test data	3
4.4 Presentation of results	6
Annex A (normative) Technical requirements of roller brake tester	8
Annex B (informative) Periodic inspection of equipment and its documentation	12
Bibliography	14

Foreword

ISO (the International Organization for Standardization) is a worldwide federation of national standards bodies (ISO member bodies). The work of preparing International Standards is normally carried out through ISO technical committees. Each member body interested in a subject for which a technical committee has been established has the right to be represented on that committee. International organizations, governmental and non-governmental, in liaison with ISO, also take part in the work. ISO collaborates closely with the International Electrotechnical Commission (IEC) on all matters of electrotechnical standardization.

International Standards are drafted in accordance with the rules given in the ISO/IEC Directives, Part 2.

The main task of technical committees is to prepare International Standards. Draft International Standards adopted by the technical committees are circulated to the member bodies for voting. Publication as an International Standard requires approval by at least 75 % of the member bodies casting a vote.

Attention is drawn to the possibility that some of the elements of this document may be the subject of patent rights. ISO shall not be held responsible for identifying any or all such patent rights.

ISO 21069-2 was prepared by Technical Committee ISO/TC 22, *Road vehicles*, Subcommittee SC 2, *Braking systems and equipment*.

ISO 21069 consists of the following parts, under the general title *Road vehicles — Test of braking systems on vehicles with a maximum authorized total mass of over 3,5 t using a roller brake tester*.

- *Part 1: Pneumatic braking systems*
- *Part 2: Air over hydraulic and purely hydraulic braking systems*

Introduction

At present, UNECE Regulation No. 13 covers only some aspects of the periodic technical inspection of vehicles in use.

In order to fulfil the requirements of UNECE Regulation No. 13, paragraph 5.1.4, this part of ISO 21069 is designed to cover the periodic measurement of braking performance of vehicles in service.

This part of ISO 21069 specifies the test method whereby a roller brake tester is used to measure, evaluate and record the braking efficiency of road vehicles of categories M2, M3, N2, N3, O3 and O4 [as defined in UNECE Consolidated Resolution on the Construction of Vehicles (R.E.3.)] which are equipped with full power air over hydraulic or purely hydraulic braking systems. This part of ISO 21069 is also applicable for electronic braking systems (EBS).

Road vehicles — Test of braking systems on vehicles with a maximum authorized total mass of over 3,5 t using a roller brake tester —

Part 2: Air over hydraulic and purely hydraulic braking systems

1 Scope

This part of ISO 21069 describes a procedure that generates comparable measurement results in roller brake testing, such that the efficiency of the service braking system can be assessed reliably wherever the roller brake tests are performed.

The following items are covered in this part of ISO 21069:

- symbols and definitions;
- test methods;
- test conditions;
- test equipment required;
- accuracy of test equipment;
- data recording and calculation needed;
- presentation of results;
- assessment criteria for pass/fail.

The procedure described in this part of ISO 21069 is not applicable to passenger cars.

2 Terms and definitions

For the purposes of this document, the following terms and definitions apply.

2.1

braking force

force between the tyre and the rotating roller, produced at the circumference of the tyre during braking, which opposes the force generated at that interface by the roller brake tester in order to cause a rotation of the wheel

2.2

braking force imbalance

difference in the braking forces, measured with running wheels, between brakes on an axle

NOTE Braking force imbalance is expressed as a percentage of the higher force.

Licensed to /HAMID REZA AZIMI
ISO Store order #:923642/Downloaded:2008-06-24
Single user licence only, copying and networking prohibited

**2.3
braking force variation**

difference between the maximum and minimum values of the braking force, measured over a single wheel revolution with a constant actuation force

NOTE Braking force variation is expressed as a percentage of the higher force.

**2.4
roller brake tester**

measuring machine consisting of two pairs of powered rollers used for the assessment of a vehicle's braking performance

NOTE The assessment is made by measuring the braking force between tyres and drive rollers for each wheel/twin wheel, either simultaneously or independently, while the wheels of the vehicle axle are being driven and supported by rollers.

3 Symbols

Table 1 — General symbols

Symbol	Definition	Unit
F_{Bi}	extrapolated braking forces at brake actuator pressure $p_{A,ladi}$	N
$\sum F_{Bi}$	sum of all F_{Bi} on all axles	N
F_{Hi}	braking force at the circumference of tyres on axle i at brake actuator pressure $p_{A,Hi}$	N
F_i	braking force at the circumference of tyres on axle i	N
F_{Li}	braking force at the circumference of tyres on axle i at brake actuator pressure $p_{A,Li}$	N
F_M	total normal static reaction of road surface on all wheels of the individual motor vehicle, or corresponding to F_i	N
$F_{M,max}$	maximum permissible F_M	N
F_R	total normal static reaction of road surface on all wheels of the individual trailer vehicle	N
$F_{R,max}$	maximum permissible normal static reaction of fully laden trailer vehicle	N
p_A	brake actuator pressure	kPa
$p_{A,Hi}$	high applicable brake actuator pressure on axle i	kPa
$p_{A,ladi}$	design brake actuator pressure of laden vehicle on axle i (for extrapolation purposes)	kPa
$p_{A,Li}$	low brake actuator pressure on axle i	kPa
R_f	ratio at the braking force line	—
R_p	ratio at the brake actuator pressure	—
z	braking rate	—
$z_{M,lad}$	braking rate of laden motor vehicle	—
$z_{R,lad}$	braking rate of laden trailer vehicle	—
NOTE Subscript i indicates axles 1, 2, 3, ... n , respectively.		

Table 2 — Symbols specific to air over hydraulic (A/H) braking systems

Symbol	Definition	Unit
C_F	conversion factor A/H converter front	—
C_R	conversion factor A/H converter rear	—
p_F	pneumatic pressure at front axle	Pa
p_{HF}	hydraulic pressure at front axle	Pa
p_{HR}	hydraulic pressure at rear axle	Pa
p_R	pneumatic pressure at rear axle	Pa
p_{RATIO}	pressure attenuation ratio of load-conscious valve	Pa/axle load

NOTE All measurements are made with the vehicle stationary.

4 Test conditions and evaluations

4.1 General

The characteristics of roller brake testers shall be as specified in Annex A.

The efficiency test for braking systems shall be carried out with reference to the following:

- legal requirements;
- data provided by the vehicle manufacturer;
- the instruction manual of the roller brake tester.

4.2 Preparation of vehicle and roller brake tester

4.2.1 Rollers and tyres shall be clean.

4.2.2 Tyre pressure shall be adjusted in accordance with the vehicle manufacturer's recommendations.

4.2.3 Additional instrumentation may measure the static axle loading without the rollers running.

4.2.4 Braking testing, for the purposes of official vehicle inspection, is to be carried out on a roller brake tester certified by the technical services. Vehicle data and the measured values shall be recorded in the forward direction.

4.3 Calculation and evaluation of test data

4.3.1 Braking efficiency calculation

4.3.1.1 General

For air over hydraulic and hydraulic braking systems, one of the major problems is to calculate the braking efficiency without using an external pressure transducer on the hydraulic brake system. There is an increased risk of leakages when measuring hydraulic systems, caused by connecting measurement devices.

The braking test may be made in the fully laden state, or in a lightly laden condition at lower actuation pressures, on the assumption that braking forces increase predictably with increasing pressure.

4.3.1.2 Provisions for air over hydraulic braking system

For the front axle, if the air over hydraulic (A/H) conversion factor (C_F) supplying the hydraulic pressure is easily calculated from the measured air pressure (p_F), then

$$p_{HF} = p_F \times C_F \quad (1)$$

In this case, the calculation is similar to the other possible extrapolation methods. A prerequisite is a pneumatic measuring gauge before the A/H converter.

For the rear axle, the calculation is similar, but the function of load sensing valves needs to be taken into account.

The characteristic of the load sensing/conscious valve shall be given in a graph or table, giving the pressure attenuation ratio against load input:

$$p_{HR} = p_R \times C_R \times p_{RATIO} \quad (2)$$

In this case, the axle load needs to be known or measured.

The calculated hydraulic pressures, p_{HR} and p_{HF} , can be used as p_{Ai} is used in Equations (5) and (6).

The actuator pressure and brake force shall be determined simultaneously and in real time.

Extrapolation of brake output forces may be used to predict the laden braking rate. This may be achieved by following one of the following extrapolation methods:

- a minimum of 30 % of the design brake actuator pressure shall be achieved by suitable loading, dead weight of the axle or by load simulation, or
- the distance between the measurement points (the first point at the beginning and the second at the cut-off point) shall be as large as possible in order to ensure the correct gradient of the function of the graph (pressure versus force).

NOTE If it is prescribed in the relevant national requirements, the rolling resistance can be treated accordingly.

A plan of an air over hydraulic braking system is given in Figure 1.

4.3.1.3 Provisions for purely hydraulic braking system

For hydraulic braking systems, it is recommended only to proceed with the test with fully laden conditions. For partly laden conditions, a load simulation is highly recommended. One possible indication for the gradation of brake forces can also be a measurement of pedal forces with special measurement equipment which is suitable for this purpose. This measurement should not be used for calculation.

4.3.2 Determination of braking force or braking rate

The braking force or, alternatively, the braking rate (maximum braking force/vertical wheel load) shall be determined for

- each wheel individually, or
- each axle individually.

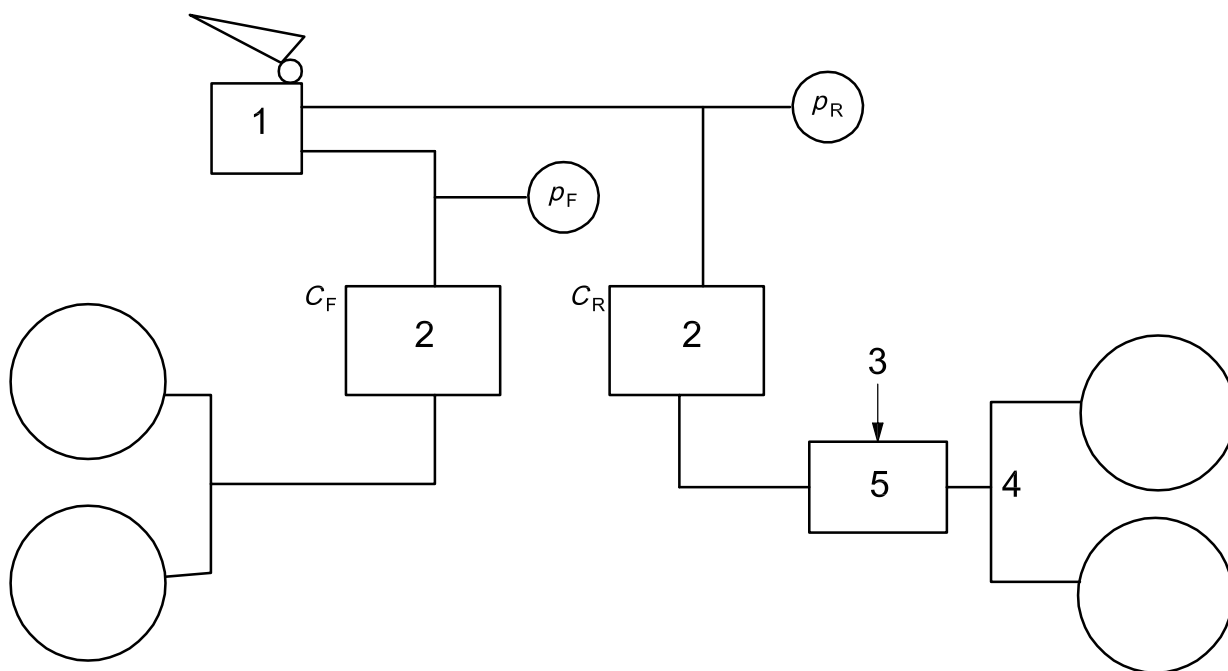

Key

- 1 foot valve
- 2 A/H converter
- 3 axle load
- 4 rear
- 5 vehicle

Figure 1 — Air over hydraulic braking system plan

4.3.3 Methods of determination

4.3.3.1 Laden measurement method

The braking rate shall be determined directly by measuring the braking forces for the vehicle in the laden condition. The laden braking rate calculation requires no extrapolation, being simply calculated according to Equation (3) in the case of motor vehicles, and according to Equation (4) in the case of towed vehicles:

$$z_{M,lad} = \frac{\sum F_i}{F_{M,max}} \quad (3)$$

$$z_{R,lad} = \frac{\sum F_i}{F_{R,max}} \quad (4)$$

4.3.3.2 Two-point measurement method

This method is only useful if the pneumatic/hydraulic converter function and the conversion factor are correctly known. In some cases, evaluation using direct measurement of hydraulic pressure is needed to ensure that the conversion factor is calculated precisely.

First, the braking force shall be measured at a low brake actuator pressure slightly above the threshold point at which braking force can be measured. The second (main) measurement shall be performed with the highest applicable braking forces, with the corresponding brake actuator pressure beneath the locking limit of the wheels.

The measured braking forces at each axle shall be extrapolated to the minimum design pressure. For a correct calculation, at least 30 % of the design brake actuator pressure is achieved by suitable loading of the axle or simulation of load.

The laden braking rate on axle i corresponds to $z_{M,lad}$ or $z_{R,lad}$, or is calculated according to Equation (5) or (6):

$$F_{Bi} = F_{Hi} + R_{Fi} (p_{A,lad} - p_{A,Hi}) \quad (5)$$

$$R_{Fi} = \frac{F_{Hi} - F_{Li}}{p_{A,Hi} - p_{A,Li}} \quad (6)$$

4.4 Presentation of results

4.4.1 General information

The test report shall contain the following general information:

- a) manufacturer or trade mark of the vehicle;
- b) vehicle category;
- c) vehicle model and tyre;
- d) vehicle identification number (VIN);
- e) number of axles;
- f) axle configuration (multi-axle assembly, bogie);
- g) maximum authorized total mass;
- h) maximum static axle load;
- i) service braking system.

4.4.2 Test results

The test report shall contain the following data from the test results:

- a) measured braking force total;
- b) reference braking forces or braking rate;
- c) brake actuator pressure for each wheel/axle;
- d) control line pressure;
- e) braking force imbalance across each axle;
- f) braking force variation on each wheel/axle;

- g) outline of roller brake tester;
- h) model;
- i) software version;
- j) serial number.

NOTE 1 Test results are rated “successful” if the minimum prescribed service braking performance, as laid down in UNECE Regulation No. 13, Annex 4, 2.1.1 (for motor vehicles) or 3.1.2.1 (for trailers), can be justifiably predicted for the laden vehicle with the minimum design pressure (see UNECE Regulation No. 13, 5.1.4.5.2).

NOTE 2 The performance values taken from UNECE Regulation No. 13 are for information purposes only. National requirements for periodical technical inspection can differ from values given in UNECE Regulation No. 13.

Annex A (normative)

Technical requirements of roller brake tester

A.1 Technical features

A.1.1 Based on maximum axle load rating that can be accommodated, roller brake testers may be built in several sizes up to the largest, which is rated for axles with a mass of up to 13 000 kg. The maximum axle load rating sets the requirement for the maximum braking force measurement, given the capability of testing in the fully laden condition. This is related in the following way.

For a maximum axle load m , expressed in tons, and acceleration g of 10 ms^{-2} , the maximum vertical static force per wheel, expressed in kilonewtons, is $\frac{mg}{2}$.

With dry adhesion, μ , of 0,7, the braking force on each roller, expressed in kilonewtons, is $\frac{mg\mu}{2} = 0,35mg$.

A.1.2 The diameter of the rollers shall not be less than 200 mm. In the case of an on-ground roller brake tester an exception is made, but the diameter of the rollers shall not be less than 150 mm.

A.1.3 The length of each roller shall not be less than 900 mm.

A.1.4 The distance between the rollers shall be such that vehicles with tyre diameters between 530 mm and 1 300 mm can be tested.

A.1.5 To achieve a locking point at a higher brake force/actuator pressure on the tested axle, the height of the roller upper surface may be increased to be 40 mm but not to more than 100 mm above the front roller.

In order to test a multi axle assembly (bogie), some rollers shall be raised. The upper surface of the rear rollers and preferably also front roller may be raised 40 mm but not more than 100 mm above the surface of the test ground.

A.1.6 The surface of the drive roller shall have a coefficient of adhesion of at least 0,7 in the dry, and 0,5 if wet, when testing with normal commercial vehicle tyres in used condition.

NOTE The effective adhesion can be reduced below these figures due to the separation of the two rollers.

A.1.7 The testing equipment shall be capable of operation at ambient temperatures in the range from at least $+5 \text{ }^\circ\text{C}$ to $+40 \text{ }^\circ\text{C}$ (optionally below $+5 \text{ }^\circ\text{C}$).

A.1.8 Should it be necessary to operate at temperatures outside this range, the local ambient temperature shall be controlled or a tester designed for more extreme conditions shall be used.

A.1.9 The installation and use of roller brake testing equipment should comply with national safety in the workplace standards. In the absence of such standards, the requirements listed below should apply as a minimum.

- a) If the test machine is equipped with an automatic roller starting function, the rollers should start only after a time delay of 3 s or more has elapsed once the axle has been placed on the roller tester.
- b) An automatic cut-off function has to be provided to avoid tyre damage. The test shall be stopped automatically if a slip of more than $27 \% \pm 3 \%$ between tyre and roller is detected.

- c) The roller drive shall stop automatically once the vehicle axle leaves the roller tester.
- d) A safety function shall be provided to ensure that both pairs of rollers can start only when they are both loaded simultaneously by the wheels of the vehicle under test.
- e) Working pits where roller brake testers are installed shall be equipped with a pit safety system.
- f) If installed over a pit, the roller brake tester shall have an automatic stop function which shall stop the roller drive whenever a person enters the dangerous area of the pit (the whole pit length or at least 2,5 m from the rollers in any direction).
- g) An emergency stop function is mandatory with stay-down stop buttons located in strategic positions.
- h) Protection of the electric/electronic controls and transmissions against electromagnetic interference and any disturbing influences shall be provided.
- i) Provisions shall be made to prevent unintended starting of the roller drive motors.

A.2 Measurement systems, ranges and resolutions

A.2.1 Measurement range

The braking force measurement range per wheel shall be as specified in the calculation in A.1.1. Examples are shown in Table A.1.

Table A.1 — Braking force measurement range per wheel

Axle load t	Design maximum braking force N
3	10 500
5	17 500
7	24 500
10	35 000
13	45 500

A.2.2 Display

The display shall resolve to 100 N or better in the range up to 5 000 N and to 500 N or better above that limit. The display shall be easily readable from a normal testing position. If equipped with an analogue scale, the diameter shall not be less than 280 mm.

A.2.3 Zero setting

The braking force display shall be set to zero without a vehicle on the rollers.

The rolling resistance of vehicle wheel and roller measured with a test vehicle in place on the rollers should be indicated as force related to the real mechanical zero and not be the basis for a new setting of the zero point.

A.2.4 Calibration

It shall be possible to calibrate the braking force measuring systems over the full measurement range including the zero reading with and without rollers turning. Instructions and the means for doing this shall be provided.

A.2.5 Wheel speed

The operating wheel speed should be in the range of 2 km/h to 6 km/h peripheral tyre speed. Throughout the braking force measurement range the speed of the roller shall not fall to less than 75 % of the free running speed.

A.3 Accuracy of the measuring devices

A.3.1 Braking force

The accuracy of the braking force measurement shall be as follows:

- below 5 000 N: within ± 100 N;
- above 5 000 N: within ± 2 % of the measured value.

Imbalance between right and left braking force measurements shall not exceed 2,5 % if the same braking force is applied to both sides.

A.3.2 Vertical load

The vertical force shall be measured with the following tolerances:

- below 10 000 N: ± 300 N;
- above 10 000 N: ± 3 % of the measured value.

A.3.3 Compressed air pressure

The brake actuator and supply air pressures shall be measured using calibrated instruments.

The tolerances shall be as follows:

- below 500 kPa: ± 10 kPa;
- above 500 kPa: ± 2 % of the measured value.

A.4 Data collection

The following parameters shall be measured/recorded:

- a) braking force of each wheel;
- b) rolling resistance of each wheel plus roller;
- c) braking force variation during each wheel revolution;
- d) braking force imbalance across each axle;

- e) pressure(s) in the brake actuator(s);
- f) control line pressure in trailers.

NOTE Annex B describes a procedure for the periodic inspection of the equipment and its documentation. Alternatively, the procedure for periodic inspection of the equipment and its documentation can be as prescribed by appropriate national or international regulations.

Annex B (informative)

Periodic inspection of equipment and its documentation

B.1 General

Check tests need to be carried out when the roller brake tester is first commissioned and thereafter at least every two years.

B.2 Visual inspection

B.2.1 Surface condition of the roller

Check the roller surface for irregularities (flat spots, roughness, wear) which would reduce the coefficient of adhesion (in accordance with A.1.6.).

B.2.2 Roller diameter

Check that roller diameter and surface roundness remains within tolerances specified by the manufacturer of the machine.

B.2.3 Conditions of indicators

Check the condition of analogue and digital indicators, displays, lamps, bells and audible warning devices.

B.2.4 Pressure lines, wiring and connections

Ensure that pressure lines, wiring and connections are in good condition and do not constitute a safety hazard.

B.2.5 Foundations of the roller brake test bench

Inspect the pit for the anchoring and foundations of the roller brake test machine and the state of cleanliness.

B.2.6 Moving parts inspection

B.2.6.1 Check clearance of moving parts.

B.2.6.2 Inspect for wear and tear (chains, bearings, etc.).

B.3 Inspection of all safety facilities

B.3.1 Check that the measuring rollers are functioning correctly.

B.3.2 Check the operation of the automatic slip cut-off function.

B.3.3 Check the operation of the emergency stop function.

B.3.4 Inspect the pit safety system for correct operation.

B.4 Measuring accuracy

B.4.1 General

Carry out the calibration to the accuracy levels specified in A.3.

B.4.2 Braking force

Recalibrate the braking force measuring system.

B.4.3 Vertical load

Recalibrate the vertical force measuring system.

B.4.4 Compressed air device(s)

Recalibrate the air pressure measuring system.

B.5 Documentation

A test report shall be issued containing the results of the test and the inspection, and signed by the person conducting the test.

Bibliography

- [1] ISO 611, *Road vehicles — Braking of automotive vehicles and their trailers — Vocabulary*
- [2] ISO 1176, *Road vehicles — Masses — Vocabulary and codes*
- [3] ISO 3833, *Road vehicles — Types — Terms and definitions*
- [4] ISO 21069-1, *Road vehicles — Test of braking systems on vehicles with a maximum authorized total mass of over 3,5 t using a roller brake tester — Part 1: Pneumatic braking systems*
- [5] UNECE Regulation No. 13, Rev.6, 2008, *Uniform provisions concerning the approval of vehicles of categories M, N and O with regard to braking*
- [6] UNECE Consolidated Resolution on the Construction of Vehicles (R.E.3.)

