**Cryogenic vessels — Toughness
requirements for materials at
cryogenic temperature —**

Part 1:
Temperatures below -80 °C

*Réipients cryogéniques — Exigences de ténacité pour les matériaux
à température cryogénique —*

Partie 1: Températures inférieures à -80 °C



COPYRIGHT PROTECTED DOCUMENT

© ISO 2016, Published in Switzerland

All rights reserved. Unless otherwise specified, no part of this publication may be reproduced or utilized otherwise in any form or by any means, electronic or mechanical, including photocopying, or posting on the internet or an intranet, without prior written permission. Permission can be requested from either ISO at the address below or ISO's member body in the country of the requester.

ISO copyright office
Ch. de Blandonnet 8 • CP 401
CH-1214 Vernier, Geneva, Switzerland
Tel. +41 22 749 01 11
Fax +41 22 749 09 47
copyright@iso.org
www.iso.org

Contents

Page

Foreword	iv
Introduction	v
1 Scope	1
2 Normative references	1
3 Terms and definitions	1
4 Toughness requirements	1
4.1 General.....	1
4.2 Steels.....	1
4.3 Aluminium or aluminium alloys.....	2
4.4 Copper or copper alloys.....	2
4.5 Test methods.....	2
4.5.1 General.....	2
4.5.2 Test piece locations for plates.....	3
4.5.3 Test piece locations for welds and heat-affected zones.....	3
4.6 Acceptance criteria.....	5
4.6.1 For impact energy.....	5
4.6.2 For lateral expansion.....	5
Bibliography	7

Foreword

ISO (the International Organization for Standardization) is a worldwide federation of national standards bodies (ISO member bodies). The work of preparing International Standards is normally carried out through ISO technical committees. Each member body interested in a subject for which a technical committee has been established has the right to be represented on that committee. International organizations, governmental and non-governmental, in liaison with ISO, also take part in the work. ISO collaborates closely with the International Electrotechnical Commission (IEC) on all matters of electrotechnical standardization.

The procedures used to develop this document and those intended for its further maintenance are described in the ISO/IEC Directives, Part 1. In particular the different approval criteria needed for the different types of ISO documents should be noted. This document was drafted in accordance with the editorial rules of the ISO/IEC Directives, Part 2 (see www.iso.org/directives).

Attention is drawn to the possibility that some of the elements of this document may be the subject of patent rights. ISO shall not be held responsible for identifying any or all such patent rights. Details of any patent rights identified during the development of the document will be in the Introduction and/or on the ISO list of patent declarations received (see www.iso.org/patents).

Any trade name used in this document is information given for the convenience of users and does not constitute an endorsement.

For an explanation on the meaning of ISO specific terms and expressions related to conformity assessment, as well as information about ISO's adherence to the World Trade Organization (WTO) principles in the Technical Barriers to Trade (TBT) see the following URL: www.iso.org/iso/foreword.html.

The committee responsible for this document is ISO/TC 220, *Cryogenic vessels*.

This second edition cancels and replaces the first edition (ISO 21028-1:2004), which has been technically revised.

ISO 21028 consists of the following parts, under the general title *Cryogenic vessels — Toughness requirements for materials at cryogenic temperature*:

- *Part 1: Temperatures below -80 °C*
- *Part 2: Temperatures between -80 °C and -20 °C*

Introduction

The use of materials at low temperatures entails special problems which are to be addressed. Consideration is to be given, in particular, to changes in mechanical characteristics, expansion and contraction phenomena and the thermal conduction of the various materials. Austenitic stainless steel can transform from the austenitic to the martensitic phase when cooled down, leading to dimensional change that needs to be considered during design.

However, the most important property to be considered is material toughness at low temperatures.

Cryogenic vessels — Toughness requirements for materials at cryogenic temperature —

Part 1: Temperatures below -80 °C

1 Scope

This part of ISO 21028 specifies the toughness requirements of metallic materials for use at a temperature below -80 °C to ensure their suitability for cryogenic vessels.

This part of ISO 21028 is not applicable to unalloyed steels and cast materials.

2 Normative references

The following documents are referred to in the text in such a way that some or all of their content constitutes requirements of this document. For dated references, only the edition cited applies. For undated references, the latest edition of the referenced document (including any amendments) applies.

There are no normative references in this document.

3 Terms and definitions

For the purposes of this document, the following terms and definitions apply.

3.1

minimum working temperature

lowest temperature likely to be reached by the vessel or by one of the vessel components during operation

4 Toughness requirements

4.1 General

The toughness of the materials used shall be either guaranteed by the material producer or verified by conducting an impact test on the material in accordance with the following requirements.

The toughness of the materials used shall be guaranteed by the material producer or cryogenic vessel manufacturer by conducting an impact test on each heat (lot) of the material in accordance with the following requirements.

Additionally, impact tests shall be performed on welded vessels as part of welding procedure qualification and production weld tests as specified in the product standard.

4.2 Steels

4.2.1 The materials used for the manufacture of the vessels, the welds and the heat-affected zone shall meet either the minimum impact energy or lateral expansion values.

a) Ferritic steels: Minimum impact energy value: 34 J/cm².

ISO 21028-1:2016(E)

NOTE 1 34 J/cm² corresponds to a 27 J energy for a full-size specimen.

b) Austenitic steels: Minimum impact energy value: 40 J/cm².

NOTE 2 40 J/cm² corresponds to a 32 J energy for a full-size specimen.

c) Minimum lateral expansion value: 0,38 mm.

4.2.2 The requirements of [4.2.1](#) apply to parent metal, welds and heat-affected zones at minimum working temperature and for the following steels.

a) Ferritic alloy steel Ni ≤ 9 %

NOTE 1 Product standards specify more stringent requirements in some cases (e.g. ISO 20421-1).

b) Austenitic stainless steels (CrNi, CrNiMo, CrNiMn, etc., see, for example, EN 10028-7)

NOTE 2 The values relate to V-notch impact test pieces as specified in ISO 148-1.

4.2.3 The extent of testing should be as follows.

a) For working temperatures warmer or equal to -196 °C, only the weld should be subjected to the impact test.

b) For working temperatures colder than -196 °C, base metal, heat-affected zones and weld metal should be impact tested. It is sufficient to perform the impact test at -196 °C, but either minimum impact energy value should be 48 J/cm² or the minimum lateral expansion value should be 0,53 mm. For the base material, the value guaranteed in the material test certificate may be used.

For working temperatures colder than -196 °C, base metal, heat-affected zones and weld metal should be impact tested. It is sufficient to perform the impact test at -196 °C, but

- minimum impact energy value should be 48 J/cm²,
- or minimum impact energy value should be 40 J/cm², if, during the welding procedure test, it was demonstrated that there are no significant differences of the impact energy values of -196 °C and the values of the lower temperature,
- or the minimum lateral expansion value should be 0,53 mm.

For the base material, the value guaranteed in the material test certificate may be used.

4.3 Aluminium or aluminium alloys

The toughness of aluminium and aluminium alloys is inherently high enough at low temperatures to render impact tests unnecessary (see, for example, ISO 6361-3 and ISO 6361-4).

4.4 Copper or copper alloys

The toughness of copper and copper alloys is inherently high enough at low temperatures to render impact tests unnecessary (see, for example, EN 1652, EN 1653, EN 1981 and EN 12163).

4.5 Test methods

4.5.1 General

The impact energy and lateral expansion values specified in [4.2](#) relate to test pieces measuring 10 mm × 10 mm with a V-notch.

For materials of thickness less than 10 mm but greater than or equal to 5 mm, test pieces with a cross-section of $10 \times e$, where e is the thickness of the material in millimetres, shall be used. If standard test pieces cannot be obtained from the material, reduced section test pieces, with a width equal to the product thickness, 7,5 mm or 5 mm, may be used as specified in ISO 148-1. A minimum value as specified in 4.2 shall be met.

Impact testing shall not be carried out on plates of thickness less than 5 mm or on their welds.

4.5.2 Test piece locations for plates

The impact test shall be performed on three test pieces. Each test piece shall be taken transverse to the rolling direction and the notch and, therefore, parallel to the direction of rolling and perpendicular to the plate surface.

4.5.3 Test piece locations for welds and heat-affected zones

4.5.3.1 For thicknesses $e \leq 10$ mm

The test pieces shall be taken as follows:

- three test pieces from the centre of the weld;
- three test pieces from the heat-affected zone created by the weld, with the notch being completely outside the fused zone but as close as possible to it;

i.e. six test pieces in total (see [Figure 1](#)).

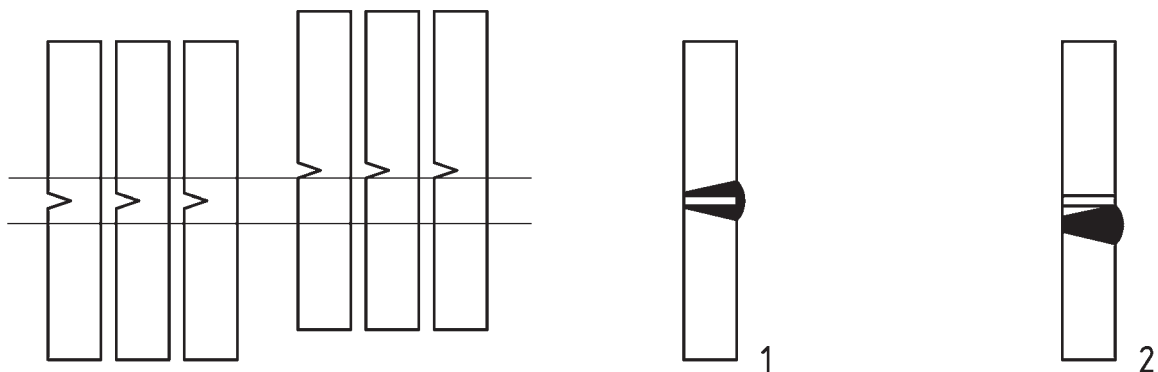

Key

- 1 centre of weld
- 2 heat-affected zone

Figure 1 — Test pieces for $e \leq 10$ mm

4.5.3.2 For thicknesses $10 \text{ mm} < e \leq 20$ mm

The test pieces shall be taken as follows:

- three test pieces from the centre of the weld;
- three test pieces from the heat-affected zone;

i.e. six test pieces in all (see [Figure 2](#)).

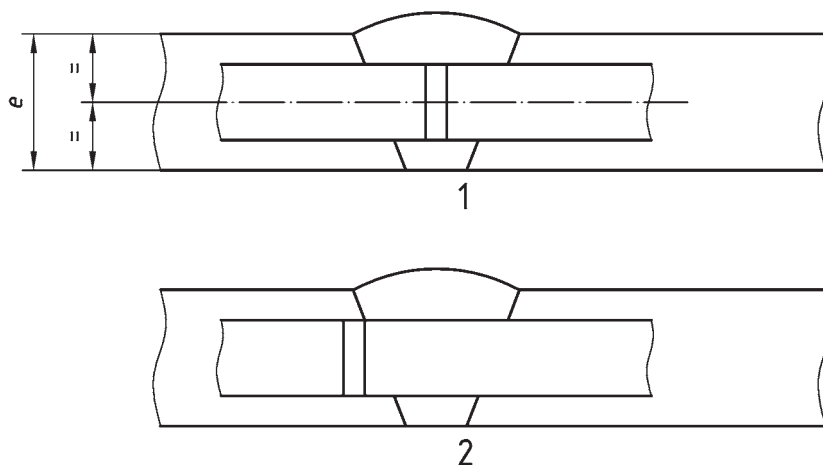

Key

- 1 centre of weld
- 2 heat-affected zone

Figure 2 — Test pieces for $10 \text{ mm} < e \leq 20 \text{ mm}$

4.5.3.3 For thicknesses $e > 20 \text{ mm}$

Two sets, each consisting of three test pieces, shall be taken at each of the two points indicated in [Figure 3](#) as follows:

- one set from the upper surface;
- the other set from the lower surface;

i.e. 12 test pieces in total (see [Figure 3](#)).

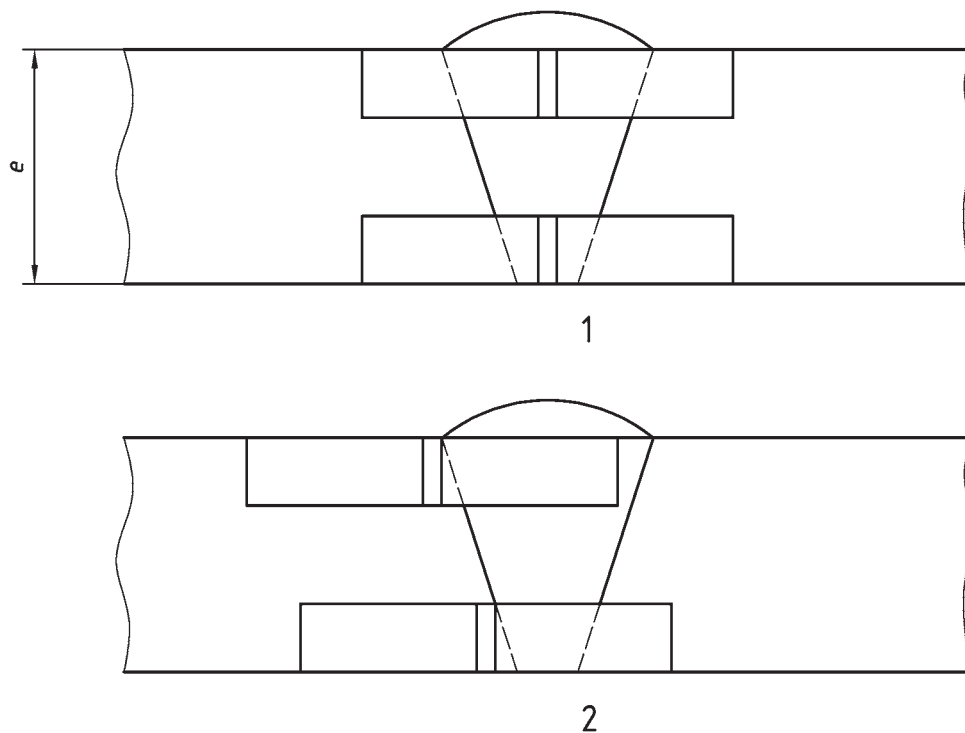
**Key**

- 1 centre of weld
- 2 heat-affected zone

Figure 3 — Test pieces for $e > 20$ mm

4.6 Acceptance criteria

4.6.1 For impact energy

The minimum impact energy values specified in this part of ISO 21028 and in EN 10028-4 correspond to the average from three test pieces. One individual value may be less than the specified value, but shall not be less than 70 % of the specified value. If the above requirements are not met, a supplementary series of three test pieces shall be taken from the same sample. The following acceptance criteria shall apply to the original results and to the results of the second test series, together, and shall be met simultaneously.

- a) The average of the six tests shall be greater than or equal to the minimum specified value.
- b) A maximum of two of the six individual values may be less than the specified minimum value.

If these conditions are not met, the sample shall be rejected and the rest of the batch shall be subjected to retests.

4.6.2 For lateral expansion

4.6.2.1 Each set of the three specimens tested shall have a lateral expansion opposite the notch of not less than the required value according to [4.2.1 c\)](#).

4.6.2.2 If the value of lateral expansion for one specimen is less than the required value according to [4.2.1 c\)](#), but not less than $2/3$ of the required value, a retest of three additional specimens may be made, each of which shall be greater than or equal to the required value.

Such a retest shall be permitted only when the average value of the three specimens is greater than or equal to the required value. If the values required are not obtained in the retest, or if the values in the initial test are less than the values required for retest, the material may be reheat-treated. After reheat-treatment, a set of three specimens shall be made, each of which shall be greater than or equal to the required value according to [4.2.1 c\)](#).

Bibliography

- [1] ISO 148-1, *Metallic materials — Charpy pendulum impact test — Part 1: Test method*
- [2] ISO 6361-3, *Wrought Aluminium and aluminium alloys — Sheets, strips and plates — Part 3: Strips: Tolerances on shape and dimensions*
- [3] ISO 6361-4, *Wrought aluminium and aluminium alloys — Sheets, strips and plates — Part 4: Sheets and plates: Tolerances on shape and dimensions*
- [4] ISO 20421-1, *Cryogenic vessels — Large transportable vacuum insulated vessels — Part 1: Design, fabrication, inspection, and tests*
- [5] ISO 21009-1, *Cryogenic vessels — Static vacuum-insulated vessels — Part 1: Design, fabrication, inspection and tests*
- [6] EN 1652, *Copper and copper alloys — Plate, sheet, strip and circles for general purposes*
- [7] EN 1653, *Copper and copper alloys — Plate, sheet and circles for boilers, pressure vessels and hot water storage units*
- [8] EN 1981, *Copper and copper alloys — Master alloys*
- [9] EN 10028-7, *Flat products made of steels for pressure purposes — Part 7: Stainless steels*
- [10] EN 10028-4:2009, *Flat products made of steels for pressure purposes — Part 4: Nickel alloy steels with specified low temperature properties*
- [11] EN 12163, *Copper and copper alloys — Rod for general purposes*
- [12] ASME Boiler and Pressure Vessel Code, Section II, Materials

