Stationary training equipment —

Part 10:

**Exercise bicycles with a fixed wheel or
without freewheel, additional specific
safety requirements and test methods**

Équipement d'entraînement fixe —

*Partie 10: Bicyclettes d'exercice avec une roue fixe ou sans roue libre,
exigences spécifiques de sécurité et méthodes d'essai supplémentaires*



PDF disclaimer

This PDF file may contain embedded typefaces. In accordance with Adobe's licensing policy, this file may be printed or viewed but shall not be edited unless the typefaces which are embedded are licensed to and installed on the computer performing the editing. In downloading this file, parties accept therein the responsibility of not infringing Adobe's licensing policy. The ISO Central Secretariat accepts no liability in this area.

Adobe is a trademark of Adobe Systems Incorporated.

Details of the software products used to create this PDF file can be found in the General Info relative to the file; the PDF-creation parameters were optimized for printing. Every care has been taken to ensure that the file is suitable for use by ISO member bodies. In the unlikely event that a problem relating to it is found, please inform the Central Secretariat at the address given below.



COPYRIGHT PROTECTED DOCUMENT

© ISO 2007

All rights reserved. Unless otherwise specified, no part of this publication may be reproduced or utilized in any form or by any means, electronic or mechanical, including photocopying and microfilm, without permission in writing from either ISO at the address below or ISO's member body in the country of the requester.

ISO copyright office
Case postale 56 • CH-1211 Geneva 20
Tel. + 41 22 749 01 11
Fax + 41 22 749 09 47
E-mail copyright@iso.org
Web www.iso.org

Published in Switzerland

Foreword

ISO (the International Organization for Standardization) is a worldwide federation of national standards bodies (ISO member bodies). The work of preparing International Standards is normally carried out through ISO technical committees. Each member body interested in a subject for which a technical committee has been established has the right to be represented on that committee. International organizations, governmental and non-governmental, in liaison with ISO, also take part in the work. ISO collaborates closely with the International Electrotechnical Commission (IEC) on all matters of electrotechnical standardization.

International Standards are drafted in accordance with the rules given in the ISO/IEC Directives, Part 2.

The main task of technical committees is to prepare International Standards. Draft International Standards adopted by the technical committees are circulated to the member bodies for voting. Publication as an International Standard requires approval by at least 75 % of the member bodies casting a vote.

Attention is drawn to the possibility that some of the elements of this document may be the subject of patent rights. ISO shall not be held responsible for identifying any or all such patent rights.

ISO 20957-10 was prepared by Technical Committee ISO/TC 83, *Sports and recreational equipment*.

ISO 20957 consists of the following parts, under the general title *Stationary training equipment*:

- *Part 1: General safety requirements and test methods*
- *Part 2: Strength training equipment, additional specific safety requirements and test methods*
- *Part 4: Strength training benches, additional specific safety requirements and test methods*
- *Part 5: Pedal crank training equipment, additional specific safety requirements and test methods*
- *Part 6: Treadmills, additional specific safety requirements and test methods*
- *Part 7: Rowing machines, additional specific safety requirements and test methods*
- *Part 8: Steppers, stairclimbers and climbers — Additional specific safety requirements and test methods*
- *Part 9: Elliptical trainers, additional specific safety requirements and test methods*
- *Part 10: Exercise bicycles with a fixed wheel or without freewheel, additional specific safety requirements and test methods*

Introduction

This part of ISO 20957 amends and supplements ISO 20957-1. The requirements of this part of ISO 20957 take priority over those in the general standard.

Stationary training equipment —

Part 10:

Exercise bicycles with a fixed wheel or without freewheel, additional specific safety requirements and test methods

1 Scope

This part of ISO 20957 specifies safety requirements for exercise bicycles with a fixed wheel or without freewheel, which have an inertia $> 0,6 \text{ kg} \cdot \text{m}^2$ in addition to the general safety requirements of ISO 20957-1. This part of ISO 20957 should be read in conjunction with ISO 20957-1.

This part of ISO 20957 is applicable to stationary training equipment type exercise bicycles with a fixed wheel or without freewheel (type 10) (hereafter referred to as training equipment) within the classes S and H.

Any attachment provided with the exercise bicycle with a fixed wheel or without freewheel for the performance of additional exercises are subject to the requirements of ISO 20957-1.

2 Normative references

The following referenced documents are indispensable for the application of this document. For dated references, only the edition cited applies. For undated references, the latest edition of the referenced document (including any amendments) applies.

ISO 4210:1996, *Cycles — Safety requirements for bicycles*

ISO 12100-1, *Safety of machinery — Basic concepts, general principles for design — Part 1: Basic terminology, methodology*

ISO 20957-1:2005, *Stationary training equipment — Part 1: General safety requirements and test methods*

EN 563, *Safety of machinery — Temperatures of touchable surfaces — Ergonomics data to establish temperature limit values for hot surfaces*

3 Terms and definitions

For the purposes of this document, the terms and definitions given in ISO 20957-1 and the following apply.

3.1

flywheel

rotating mass designed to create inertia

3.2

freewheel

gearing mechanism that is designed to disengage the flywheel from the pedal mechanism in one direction

3.3

seat pillar

connection between the frame and the seat, provided to adjust the height of the seat

- 3.4**
seat tube
part of the frame where the seat pillar is inserted
- 3.5**
handlebar stem
connection between the frame and the handlebar, provided to adjust the height of the handlebar
- 3.6**
emergency brake
equipment designed to stop the movement of the pedals in case of emergency
- 3.7**
locking system
mechanism designed to immobilize any rotating part of the equipment which cannot be operated without the use of a specific tool, e.g., a key
- 3.8**
dynamic direction
direction in which the force is applied during normal exercise as described in the user's manual
- 3.9**
housing
encasement of potentially hazardous elements
- 3.10**
transmission guard
encasement of potentially hazardous transmission elements

4 Classification

Only the classification as defined in 4.4 of ISO 20957-1:2005 applies.

5 Safety requirements

5.1 External construction

5.1.1 Transmission elements and rotating parts, squeeze and shear points

Training equipment on which the pedal cranks have a greater diameter than the housing, shall have a distance between the pedal cranks and the stationary parts of the construction of not less than 10 mm. This requirement does not apply if the housing has a greater diameter than the pedal crank.

Transmission elements shall be covered in accordance with ISO 12100-1. All other parts shall be tested with the test finger in accordance with ISO 20957-1. The test finger shall not become trapped or come into contact with moving parts that do not have a smooth surface. The radius of the edge of the flywheel shall be at least 2,5 mm. The edges of the pedals shall be free of burrs, rounded or protected in some other way.

Test in accordance with 6.1.1 and 6.2.

5.1.2 Temperature rise

When tested in accordance with 6.3, accessible parts of the equipment shall not have a temperature greater than 65 °C.

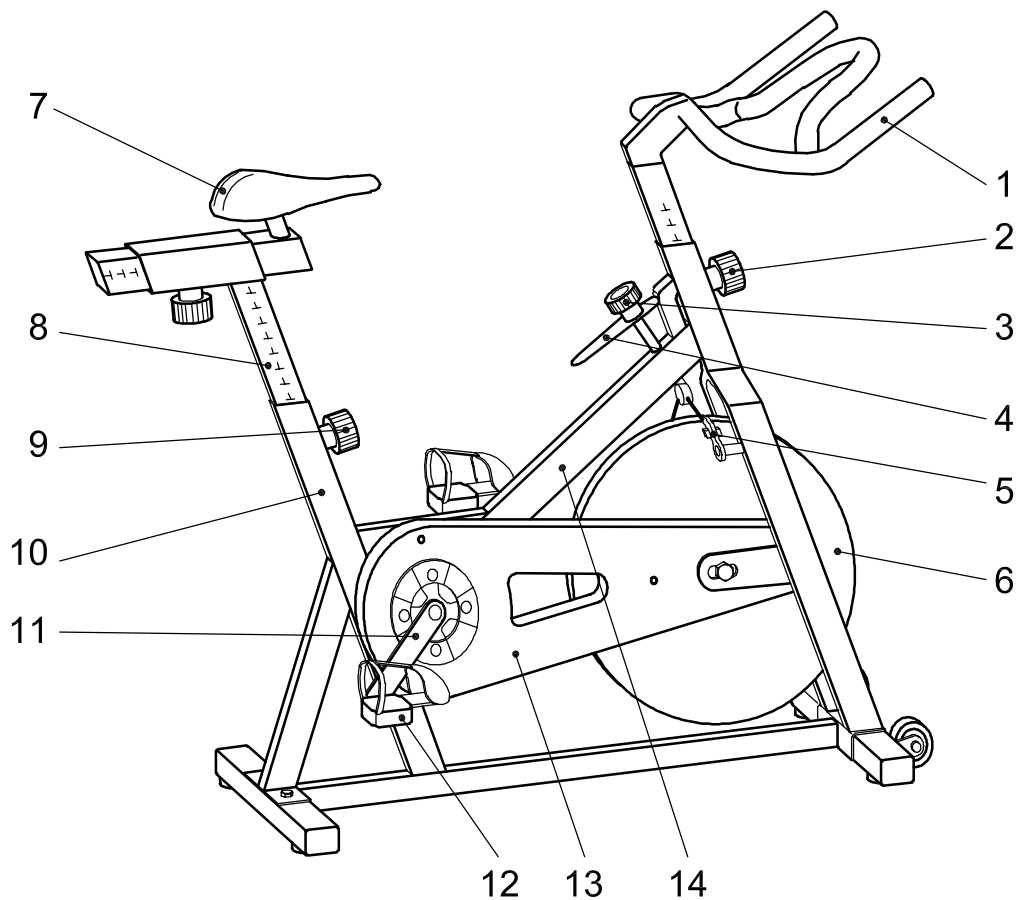

Key

- 1 handlebar
- 2 handlebar adjustment
- 3 resistance adjustment
- 4 emergency brake
- 5 resistance system (brake)
- 6 flywheel
- 7 seat
- 8 seat pillar
- 9 seat adjustment
- 10 seat tube
- 11 pedal crank
- 12 pedal
- 13 transmission guard
- 14 frame

Figure 1 — Example of an exercise bicycle without freewheel

5.2 Intrinsic loading

For class S, the seat pillar shall be tested with $4 \times$ the maximum body mass specified by the manufacturer, or 4 000 N, whichever is greater. For class H, the seat pillar shall be tested with $3 \times$ the maximum body mass specified by the manufacturer, or 3 000 N, whichever is greater. For both classes, the pedals and the crank shall be tested with $4 \times$ the maximum body mass specified by the manufacturer, or 4 000 N, whichever is greater.

Testing in accordance with 6.4.

The seat shall be in accordance with ISO 4210.

After testing in accordance with 6.4, the training equipment shall be capable of functioning according to the manufacturer's information on correct use.

During testing of the seat pillar and the pedals, the training equipment shall not tip over.

The clamped seat pillar shall not slip by more than 5 mm into the seat tube during the test.

5.3 Seat pillar — Seat

5.3.1 General

The height of the seat shall be adjustable without use of a tool for class S equipment.

For class H, if a tool is required to adjust the seat height, it shall be provided by the manufacturer and clear instructions on how to use it shall be given in the user's instruction manual.

5.3.2 Insertion depth

The minimum insertion depth of the seat pillar in its highest position shall be 55 mm.

The seat pillar shall have a permanent mark and the word "STOP" indicating the minimum insertion depth. The mark may be dispensed with if the minimum insertion depth is given by the design.

With locking systems, there shall be a minimum insertion depth of 55 mm in the highest position.

Test in accordance with 6.1.1 and 6.1.2

5.4 Handlebar

5.4.1 Handlebar stem

The handlebar stem shall be adjustable without use of a tool, or different grip positions shall be possible for class S equipment.

For class H, if a tool is required to adjust the handlebar stem it shall be provided by the manufacturer and clear instructions on how to use it shall be given in the user's instruction manual.

The minimum insertion depth of the handlebar stem in its highest position shall be 55 mm.

The handlebar stem shall have a permanent mark and the word "STOP" indicating the minimum insertion depth. The mark may be dispensed with if the minimum insertion depth is given by the design.

Test in accordance with 6.1.1 and 6.1.2.

5.4.2 Handlebar

For both classes, the handlebar shall be tested with $1,5 \times$ the maximum body mass specified by the manufacturer, or 1 500 N, whichever is greater. The test load shall be applied vertically and with a force of $0,5 \times$ the maximum body mass specified by the manufacturer, or 500 N, whichever is greater, applied horizontally. The handlebar shall withstand the force without breakage or permanent deformation of more than 10 %.

Testing in accordance with 6.5.

After the test the handlebar shall function according to the manufacturer's instructions.

5.5 Pedals

The pedals shall include a system which maintains the foot in a position that precludes unintended movement.

5.6 Pedal crank assembly

When tested in accordance with 6.8, the pedal crank assembly shall withstand a force of (750 ± 10) N applied dynamically for 1 000 000 cycles with a frequency of maximum 25 Hz for class S and 120 000 cycles for class H. After applying a static load of 4 000 N, the pedal crank assembly shall not display any signs of fracture or structural failure.

5.7 Stability

When tested in accordance with 6.6, the training equipment shall not fall over when performing any of the exercises described in the user's manual.

5.8 Locking system

The exercise bicycle with a fixed wheel or without freewheel for home use (class H) shall be equipped with a locking system to prevent the uncontrolled use or movement of any rotating part of the equipment by third parties, especially children.

5.9 Emergency braking system

Exercise bicycles with a fixed wheel or without freewheel shall be equipped with an emergency brake. This brake shall be easily accessible and visible from the user's position and shall be capable of bringing the equipment to a stop (in both directions) within one complete revolution of the crank and activated with a downforce (push) of maximum 100 N or an upforce (pull) of maximum 50 N.

Test in accordance with 6.7.

The actuator of the emergency brake shall be coloured RED. If there is a background, the background shall be coloured YELLOW. The actuator of a push-button operated switch shall be of the palm or mushroom head type.

A braking system similar to a bicycle handbrake shall fulfil the dimensions in accordance with Figure 2. The grip dimension, d , shall not exceed 90 mm at point B and 100 mm between points B and C.

The brake lever shall withstand the test in accordance with 6.7 without breakage or permanent deformation of more than 3 %.

Dimensions in millimetres

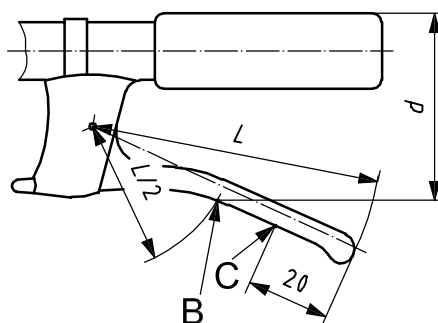

Figure 2 — Brake lever dimensions

5.10 Foot clearance

The vertical distance between any rigid component of the pedal and the floor, or any frame member on the floor, shall be at least 60 mm.

6 Test methods

6.1 General

6.1.1 Dimensional check.

6.1.2 Visual examination.

6.1.3 Tactile examination.

6.1.4 Performance test.

6.2 Testing of transmission elements and rotating parts, squeeze and shear points

The apparatus shall comprise a test finger in accordance with ISO 20957-1.

Approach all moving parts from all sides with the test finger probe to determine whether the finger probe can become trapped.

Determine whether the test finger probe is trapped.

6.3 Testing of temperature rise

The apparatus shall comprise a contact thermometer, with an accuracy of ± 1 °C.

Test room temperature shall be between 18 °C and 25 °C.

Pedal the training equipment at 200 W at 60 min⁻¹ for three periods of 20 min.

After each 20 min period, rest for 5 min.

After the 3rd period measure the temperature.

See also EN 563.

6.4 Testing of intrinsic loading

The test shall be performed without the seat in the most onerous position.

Apply the static load as described in 5.2 for 5 min.

Determine the possibility of the equipment tipping over and check against any breakage.

Remove the load and determine the reference dimensions of the seat pillar.

6.5 Testing of handlebars

Apply the vertical and horizontal static loads as described in 5.4.2 at the same time in the most onerous position for 5 min.

6.6 Testing of stability

Perform the test at 10° in the most onerous direction at 100 min^{-1} for 1 min and in the following positions:

- a) sitting with hands on the handlebars;
- b) sitting with hands off the handlebars;
- c) standing with hands on the handlebars.

Place the training equipment on a level surface. Place the seat post in its highest position and the seat in the furthest rearward position.

Load the seat of the training equipment with $(100 \pm 5) \text{ kg}$ or the maximum body mass as described in the user's manual, whichever is greater. Make sure that the centre of gravity of the test mass is $(300 \pm 20) \text{ mm}$ above the seat.

6.7 Testing of the emergency braking system

Pedal the exercise bicycle with a fixed wheel or without freewheel at 120 min^{-1} without resistance. Activate the brake with the relevant force given in 5.9 in the centre of the brake mechanism (e.g. lever) and observe if the pedal crank comes to a stop within 1 revolution.

The handbrake shall be subjected to a force of 300 N for at least 15 s. The force shall be applied in the field of operation in the most onerous position.

6.8 Testing of the pedal crank assembly

Fix the exercise bicycle frame complete with pedal crank assembly to a test rig and apply the specified load on to one pedal in its lowest position. The load shall be placed on the centre point of the pedal axle or shaft (see Figure 3).

After the dynamic test, apply the static load as described in 5.2.

7 Additional instructions for use

In addition to ISO 20957-1, easy-to-understand instructions for use shall be supplied with each exercise bicycle with a fixed wheel or without freewheel.

The instructions for use shall include at least:

- a) a statement to explain the risk caused by the absence of a freewheel system;
- b) instructions of the method required to operate the emergency brake;
- c) instructions describing the method required to stop training;
- d) instructions describing the operation of the locking mechanism for class H;
- e) instructions to explain that class S training equipment shall always be used in a supervised environment;
- f) instructions describing the requirement to use the foot positioning system described in 5.5;
- g) instructions to explain the importance of adjusting the handlebar and the seat to suit the user; this adjustment shall not exceed the mark "STOP" indicating the minimum insertion depth, unless otherwise prevented by the design;
- h) instructions on the use of any tools used for adjustment in class H equipment.

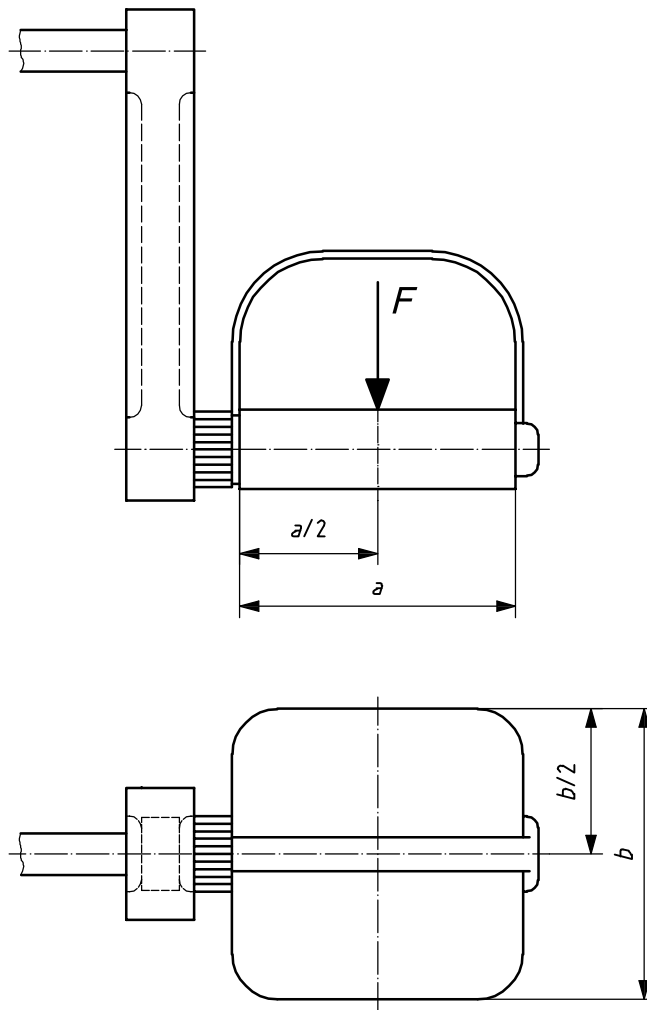

Figure 3 — Testing of the pedal

8 Additional marking

All exercise bicycles with a fixed wheel or without freewheel shall be marked with a pictogram instructing the user to read the information supplied by the manufacturer (see Figure 4).

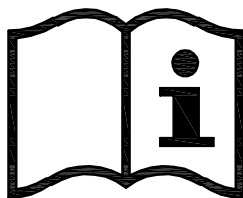

Figure 4 — Pictogram marking

Home use exercise bicycles with a fixed wheel or without freewheel shall be marked with a warning label instructing the user to lock the equipment when not in use.

Class S exercise bicycles with a fixed wheel or without freewheel shall be marked with a warning label instructing that the equipment shall be used in a supervised environment.

All labels shall be placed in a visible position.

