Stationary training equipment —
Part 1:
General safety requirements and test
methods

Équipement d'entraînement fixe —

Partie 1: Exigences générales de sécurité et méthodes d'essai



Reference number
ISO 20957-1:2013(E)

© ISO 2013



COPYRIGHT PROTECTED DOCUMENT

© ISO 2013

All rights reserved. Unless otherwise specified, no part of this publication may be reproduced or utilized otherwise in any form or by any means, electronic or mechanical, including photocopying, or posting on the internet or an intranet, without prior written permission. Permission can be requested from either ISO at the address below or ISO's member body in the country of the requester.

ISO copyright office
Case postale 56 • CH-1211 Geneva 20
Tel. + 41 22 749 01 11
Fax + 41 22 749 09 47
E-mail copyright@iso.org
Web www.iso.org

Published in Switzerland

Contents

	Page
Foreword	iv
Introduction	v
1 Scope	1
2 Normative references	1
3 Terms and definitions	2
4 Classification	4
4.1 General	4
4.2 Accuracy classes	4
4.3 Usage classes	4
5 Safety requirements	5
5.1 General	5
5.2 Stability of equipment	5
5.3 External construction	5
5.4 Entrapment of the user	6
5.5 Adjustment components and locking mechanisms	6
5.6 Ropes, belts, chains and attachment components	6
5.7 Pull-in points	7
5.8 Hand grips	7
5.9 Endurance test	7
5.10 Isometric test requirements	8
5.11 Heart rate measurement system	8
5.12 Heart rate control mode	8
5.13 Electrical safety	8
5.14 Loading	8
5.15 Care and maintenance	9
5.16 Assembly instructions	9
5.17 General instructions for use	10
5.18 Marking	10
6 Test methods	11
6.1 Test conditions	11
6.2 Stability test	11
6.3 External construction	11
6.4 Testing of entrapment	12
6.5 Adjustment components and locking mechanisms	12
6.6 Tensile test for ropes, belts, chains and attachment components	12
6.7 Testing of rope and belt guides	12
6.8 Testing of flywheels	12
6.9 Testing of integral handgrips	13
6.10 Determination of the removing force of applied handgrips	13
6.11 Testing of rotating handgrips	13
6.12 Testing of endurance load	13
6.13 Testing of isometric equipment	13
6.14 Testing of the heart rate measurement system	14
6.15 Testing of the heart rate control mode	14
6.16 Testing of intrinsic loading	14
6.17 Testing of extrinsic loading	14
6.18 Testing of care and maintenance, assembly instructions, general instructions for use and marking	14
6.19 Test report	14
Bibliography	16

Foreword

ISO (the International Organization for Standardization) is a worldwide federation of national standards bodies (ISO member bodies). The work of preparing International Standards is normally carried out through ISO technical committees. Each member body interested in a subject for which a technical committee has been established has the right to be represented on that committee. International organizations, governmental and non-governmental, in liaison with ISO, also take part in the work. ISO collaborates closely with the International Electrotechnical Commission (IEC) on all matters of electrotechnical standardization.

The procedures used to develop this document and those intended for its further maintenance are described in the ISO/IEC Directives, Part 1. In particular the different approval criteria needed for the different types of ISO documents should be noted. This document was drafted in accordance with the editorial rules of the ISO/IEC Directives, Part 2. www.iso.org/directives

Attention is drawn to the possibility that some of the elements of this document may be the subject of patent rights. ISO shall not be held responsible for identifying any or all such patent rights. Details of any patent rights identified during the development of the document will be in the Introduction and/or on the ISO list of patent declarations received. www.iso.org/patents

Any trade name used in this document is information given for the convenience of users and does not constitute an endorsement.

ISO 20957-1 was prepared by Technical Committee ISO/TC 83, *Sports and recreational equipment*, and by Technical Committee CEN/TC 136, *Sports, playground and other recreational facilities and equipment*, in collaboration.

ISO 20957 consists of the following parts, under the general title *Stationary training equipment*:

- *Part 1: General safety requirements and test methods*
- *Part 2: Strength training equipment, additional specific safety requirements and test methods*
- *Part 4: Strength training benches, additional specific safety requirements and test methods*
- *Part 5: Pedal crank training equipment, additional specific safety requirements and test methods*
- *Part 6: Treadmills, additional specific safety requirements and test methods*
- *Part 7: Rowing machines, additional specific safety requirements and test methods*
- *Part 8: Steppers, stairclimbers and climbers — Additional specific safety requirements and test methods*
- *Part 9: Elliptical trainers, additional specific safety requirements and test methods*
- *Part 10: Exercise bicycles with a fixed wheel or without freewheel, additional specific safety requirements and test methods*

Part 3 has been amalgamated with Part 2 after CEN Enquiry.

Introduction

This part of ISO 20957 specifies safety requirements that are applicable to all stationary training equipment. For specific types of equipment these requirements are supplemented or modified by the requirements of specific standards which have been issued as additional parts of this International Standard.

Where a specific part of ISO 20957 exists, this part of ISO 20957 should be used in conjunction.

© ISO 2012. All rights reserved.

Stationary training equipment —

Part 1: General safety requirements and test methods

1 Scope

This part of ISO 20957 specifies general safety requirements and test methods for stationary training equipment unless modified in the other parts of this International Standard. This part of ISO 20957 also covers environmental aspects.

It also specifies a classification system (see [Clause 4](#)).

This part of ISO 20957 is applicable to all stationary training equipment as defined in [3.1](#). This includes equipment for use in training areas of organizations such as sport associations, educational establishments, hotels, sport halls, clubs, rehabilitation centres and studios (classes S and I) where access and control is specifically regulated by the owner (person who has the legal responsibility), equipment for domestic use (class H) and other types of equipment including motor driven equipment as defined in [3.1](#).

The requirements of a specific part of ISO 20957 take priority over the corresponding requirements of this general standard.

If the intended use of the stationary training equipment is for children under 14 years other standards are applicable unless such stationary training equipment is intended for educational purposes in schools and other pedagogical contexts for children under the surveillance of a qualified adult instructor.

This part of ISO 20957 does not apply to stationary training equipment intended for outdoor use without supervision e.g. freely accessible.

NOTE 1 If a user has special needs (medical rehabilitation, disability) it is essential that the owner (the person with legal responsibility) conducts a specific risk assessment to determine safe use and if necessary to ensure trained staff are available to supervise the activity.

NOTE 2 In the event that the stationary training equipment is intended for medical purposes, attention is drawn to the requirements of Council Directive of 14 June 1993 on the approximation of the laws of the Member States relating to medical devices 93/42/EEC in addition to the requirements of this part of ISO 20957.

NOTE 3 In the event that the stationary training equipment is intended for children's purposes, attention is drawn to the requirements of Council Directive of 18 June 2009 on the approximation of the laws of the Member States relating to safety of toys 2009/48/EC in addition to the requirements of this part of ISO 20957.

NOTE 4 In the event that the stationary training equipment is designed to be accessible to people with disability, attention is drawn to any relevant national guidelines.

NOTE 5 Concerning flammability, attention is drawn to national regulations.

NOTE 6 In the event that the stationary training equipment contains environmental critical components, attention is drawn to national regulations, e.g. European Directives.

2 Normative references

The following documents, in whole or in part, are normatively referenced in this document and are indispensable for its application. For dated references, only the edition cited applies. For undated references, the latest edition of the referenced document (including any amendments) applies.

ISO 20957-1:2013(E)

ISO 6508-1, *Metallic materials — Rockwell hardness test — Part 1: Test method*

ISO 12100, *Safety of machinery — General principles for design — Risk assessment and risk reduction*

EN 60335-1, *Household and similar electrical appliances — Safety — Part 1: General requirements*

EN 60601-1, *Medical electrical equipment — Part 1: General requirements for basic safety and essential performance*

3 Terms and definitions

For the purposes of this document, the following terms and definitions apply.

3.1 stationary training equipment
equipment that is not moved as a unit during use and either stands freely on the floor or is attached to a floor, wall, ceiling or other fixed structure

Note 1 to entry: Stationary training equipment can be used for example for the following:

- a) body building or body styling;
- b) health/fitness training;
- c) physical education;
- d) training specific to competition and related sports activities;
- e) preventive treatment and rehabilitation.

3.2 training area
area occupied by the user and the equipment while exercising over the full range of movement

3.3 safe operational area
area in which no third party has access to dangerous parts of the equipment when in use

3.4 free area
area in addition to the training area which is required for the user or third party to access the equipment and/or conduct an emergency dismount over and above the full range of movement

3.5 accessible hand and foot area
area accessible to user or to third parties when the equipment is in normal use, during setting up, grasping, adjusting the equipment or the position of the body for exercise

3.6 range of movement
space in which the user or part of the equipment is moving according to the instructions given in the user's manual

3.7 dynamic direction
direction in which the force is applied during a normal exercise as described in the user's manual

3.8 bodymass
maximum specified user mass as described in the user's manual or 100 kg, whichever is greater

3.9**intrinsic loading**

loading due to the body mass

3.10**extrinsic loading**

load applied to the product from any other source than the body mass

3.11**maximum specified load**

maximum load specified by the manufacturer in the user's manual and the marking

3.12**ergometer**

piece of stationary training equipment that measures the input of power in Watts with a specific accuracy as defined in the specific part of the standard

Note 1 to entry: This term can only be used for stationary training equipment, which fulfils this condition.

3.13**speed dependent training equipment**

training equipment in which the resistance cannot be adjusted and is proportional to the speed

EXAMPLE Air fan resistance devices.

3.14**speed independent training equipment**

training equipment in which the resistance can also be adjusted by other means than speed

EXAMPLE Adjustable braking mechanism.

3.15**power driven training equipment**

training equipment which is driven by external power

EXAMPLE Electric motors.

3.16**heart rate control mode**

programme that allows the user to maintain training with a predetermined heart rate level by adjusting the resistance automatically to the user's heart rate response

3.17**heart rate measurement system**

system which displays the individual heart rate of the user

3.18**display**

device that provides information to the user

3.19**squeeze point**

place where parts of the equipment can move against each other, or against a fixed area, which may result in parts of user's/third person's body being crushed

3.20**shear point**

place where part of the equipment can move past a fixed or moving part, or past a fixed area, which may result in parts of user's/third person's body being cut

**3.21
cycle**

movement associated to one complete operation of a single component from start to start of a repetitive process

EXAMPLE A typical component could be a pedal, handlebar or seat.

**3.22
multiple exercise station**

part of the equipment allowing more than one functional units or exercises

4 Classification

4.1 General

Equipment shall be classified in accordance with accuracy and usage classes as described in [4.2](#) to [4.3](#).

If the intended use of the equipment is for more than one usage class it shall fulfil the requirements of each class.

4.2 Accuracy classes

4.2.1 Accuracy classes only apply to equipment which display training data.

4.2.2 Class A: high accuracy.

4.2.3 Class B: medium accuracy.

4.2.4 Class C: low accuracy.

NOTE The requirements of accuracy classes are shown in the additional specific parts of this International Standard.

4.3 Usage classes

4.3.1 Class S (Studio): professional and/or commercial use.

NOTE Such stationary training equipment is intended for use in training areas of organizations such as sport associations, educational establishments, hotels, clubs and studios, where access and control is specifically regulated by the owner (person who has the legal responsibility).

4.3.2 Class H (Home): domestic use.

NOTE Such stationary training equipment is intended for use in private homes where access to the equipment is regulated by the owner (person who has the legal responsibility).

4.3.3 Class I: professional and/or commercial use provided for inclusive use for people with special needs (e.g. visual, hearing, physical or learning disabilities).

Such equipment shall also be in compliance with class S requirements (see [4.3.1](#)).

NOTE Such stationary training equipment is intended for use in training areas of organizations such as sport associations, educational establishments, hotels, clubs, rehabilitation centres and studios, where access and control is specifically regulated by the owner (person who has the legal responsibility).

5 Safety requirements

5.1 General

If any of the following safety requirements are applicable, the equipment shall meet the requirements using the test methods described in [Clause 6](#).

5.2 Stability of equipment

The stationary training equipment shall be stable in any direction, in training, folding and storage positions.

The test shall be in accordance with [6.2](#).

5.3 External construction

5.3.1 Edges and corners

All edges and corners of surfaces supporting bodies shall have a radius $r \geq 2,5$ mm.

All other edges of components which are accessible to the user or to third parties shall be free of burrs, rounded or protected.

Test in accordance with [6.3.1](#).

5.3.2 Tube ends

When tested in accordance with [6.3.2](#), accessible tube ends shall be closed off, e.g. by parts of the equipment or by plugs.

If plugs are used, they shall remain in position at the end of the endurance load test, as described in the relevant parts of the applicable specific standards. If no endurance test is described in a specific standard the pullout force of the plug shall be ≥ 20 N.

5.3.3 Squeeze and shear points within the accessible hand and foot area

Squeeze and shear points between moving parts, between moving parts and fixed parts, or between a moving part and the floor shall be guarded or shall have a minimum clearance of at least 60 mm, except as follows:

- a) if only the fingers are at risk, the dimension shall be at least 25 mm;
- b) if third party access is prevented by the user's body position, and where the user is able to immediately stop the movement, the distance shall be at least 25 mm;
- c) if the angle between two adjacent moving parts or between a rigid part and an adjacent moving part is always 50 degrees or greater, it is not considered a shear point;
- d) open and obvious stops are excluded; however, if the stop is the part which is moving, then it shall pass no closer than 25 mm from any fixed frame member throughout its range of movement.

All products shall fulfil the above requirements during use.

For foldable products during folding or unfolding, the above requirements are waived if the following three requirements are simultaneously met:

- inadvertent movement is not possible during folding, unfolding, transportation and/or storage;
- access to squeeze and shear points remain at all times in the user's field of vision;
- the user can stop the motion at any time.

Test in accordance with [6.3.3](#).

5.3.4 Squeeze and shear points as well as rotating and reciprocating points in the accessible hand and foot area

The distance between movable parts or between a movable and a fixed part shall be at least 60 mm except as follows:

- a) if only fingers are at risk, the dimension shall not be less than 25 mm;
- b) if the distance between the moving part and fixed part, or between two moving parts, does not change during use or setup, the distance shall be greater than 25 mm or less than 9,5 mm;
- c) open and obvious stops are excluded. However, if the stop is the part which is moving, then it shall pass no closer than 25 mm to any fixed frame member throughout its range of movement.

Test in accordance with [6.3.3](#).

5.3.5 Weights and resistant means

The range of motion of all weights attached to the stationary training equipment shall be limited to that required to perform the exercise. Test in accordance with [6.3.4](#).

Weights and resistant means with stored energies (e.g. bungee cords, elastic tubes, mechanical springs) shall move freely and return to the starting point.

Weights shall be securely retained during use.

5.4 Entrapment of the user

The possibility of users not being able to exit the equipment when using it according to the user's manual shall be avoided (e.g. providing assisted means of escape).

Test in accordance with [6.4](#).

5.5 Adjustment components and locking mechanisms

Adjustment components and locking mechanisms on the stationary training equipment shall function securely, be conspicuous, self-evident and safely accessible to the user. The possibility of unintended change shall be eliminated.

Adjustment components and locking mechanisms e.g. knobs and levers shall not interfere with the user's range of movement.

Weight selection pins shall be fitted with a retention device to prevent unintended change or movement during the exercise.

Test in accordance with [6.5](#).

5.6 Ropes, belts, chains and attachment components

5.6.1 General

Ropes, belts, chains and their attachment components (e.g. snap links, shackles, carabineers, clamps or similar) shall have a safety factor against breakage of 6 times the maximum possible tension that can be developed. The design of the pulleys and the bending radius shall be in accordance with the applicable requirements of the rope, belt or chain manufacturers.

Ropes, belts, chains and their attachment components shall not break and function as described in the user's manual.

Test in accordance with [6.6](#).

5.6.2 Ropes and belts

Rope and belt ends shall be, as a minimum, flush with the end of the termination means and shall be visible for inspection.

Pressed connections shall not be subjected to bending.

Rope and belt ends and grips shall have no sharp edges or frayed ends.

Test in accordance with [6.6](#).

5.6.3 Rope and belt guides

A means shall be provided to prevent a rope or a belt becoming unintentionally disengaged during use or set-up.

Test in accordance with [6.7](#).

5.7 Pull-in points

Pull-in points of rope or belt drives up to 1 800 mm height shall be protected except if the surface pressure is $\leq 90 \text{ N/cm}^2$ or when access to the pull-in point is prevented by the user's body during exercising.

This may be achieved by ensuring that the angle between the rope and the guard is not less than 50° in all positions. The guard shall not rotate together with the pulley.

Test in accordance with [6.3.5](#).

Pull-in points for chains, gears and sprockets shall be protected in accordance with ISO 12100.

For flywheels the test finger (see [Figure 1](#)) shall not become trapped when tested in accordance with [6.8](#).

5.8 Hand grips

5.8.1 Integral handgrips

Gripping positions shall be easily identifiable and designed to reduce slipping (e.g. textured, coated, knurled). Test in accordance with [6.9](#).

5.8.2 Applied handgrips

When tested in accordance with [6.10](#), applied handgrips shall not be removed. Applied handgrips shall be equipped with a surface that reduces hand slip.

5.8.3 Rotating handgrips

Rotating handgrips shall be secured during use and shall be designed to reduce slipping (e.g. textured). Test in accordance with [6.11](#).

5.9 Endurance test

The stationary training equipment shall function as specified in the manufacturer's instructions after the test has been carried out. Test in accordance with [6.12](#).

5.10 Isometric test requirements

If the stationary training equipment is designed to perform an isometric test, then the load or force on the user's body shall be displayed with an accuracy of $\pm 10\%$ in the range of measurement given in the user's manual and the read outs shall be SI units.

Test in accordance with [6.13](#).

5.11 Heart rate measurement system

The function of the heart rate measurement system shall be indicated on the display when the equipment is receiving a usable signal from the user, e.g. a blinking heart.

Test in accordance with [6.14](#).

5.12 Heart rate control mode

The function of the heart rate measurement system shall be permanently indicated on the display when the equipment is receiving a usable signal from the user, e.g. a blinking heart.

The loss of heart rate signal shall result in effort intensity remaining at the same intensity for maximum 60 s and then decrease until the minimum intensity is reached. The rate of decrease shall be at least 10 % in each 20 s time period.

Test in accordance with [6.15](#).

5.13 Electrical safety

Concerning electrical and electronic aspects of stationary training equipment EN 60335-1 shall be applied. For medical devices EN 60601-1 shall be applied.

5.14 Loading

5.14.1 Intrinsic loading

Each piece of equipment loaded with the user's body mass shall withstand a force F of 2,5 times the body mass.

After the test the equipment shall not be broken and shall still function as intended by the manufacturer.

Test in accordance with [6.16](#).

5.14.2 Extrinsic loading

When tested according to [6.3.4](#) and loaded with the user's bodymass and/or reaction forces or moments of the user as well as other forces or moments caused by any other source (e.g. additional weights supported by a stand), each piece of equipment shall withstand a load F according to Formula (1):

$$F = [Gk + 1,5 G] \cdot 2,5 \cdot 9,81\text{m/s}^2 \quad (1)$$

where

F is the load in newton;

G is the maximum load in kilograms indicated by the manufacturer (see [5.17](#));

Gk is the load in kilograms applied by the bodymass to the support being tested;

1,5 is the dynamic factor;

2,5 is the safety factor.

After the test the equipment shall not be broken and shall still function as intended by the manufacturer.

Test in accordance with [6.17](#).

5.15 Care and maintenance

Care and, if applicable, maintenance advice shall be provided with each piece of equipment. The advice shall include at least:

- a) a warning notice to the effect that the safety level of the equipment can be maintained only if it is examined regularly for damage and wear, e.g. ropes, pulleys, connection points;
- b) an advice to replace defective components immediately and/or keep the equipment out of use until repair;
- c) special attention to components most susceptible to wear.

Test in accordance with [6.18](#).

5.16 Assembly instructions

If the stationary training equipment requires assembly, then a manual shall be supplied (in the national language), giving clear and accurate assembly instructions relating to the stationary training equipment and with an emphasis on safe assembly.

If the stationary training equipment requires assembly, then a list of tools needed shall be provided.

If the stationary training equipment requires assembly, then a comprehensive parts list shall be supplied, including identifying part numbers.

The manufacturer shall indicate the total mass and the total surface area (e.g. foot print) of equipment.

When stationary training equipment is attached/anchored, e.g. to a wall or the floor, assembly instructions including the attaching/anchoring operations shall be provided.

The manufacturer shall provide the minimum value (force) each attachment shall support.

Test in accordance with [6.18](#).

5.17 General instructions for use

Each item of stationary training equipment shall be accompanied by a user's manual, in the national language including at least the following information.

- a) Customer service address.
- b) Full address of the manufacturer or importer.
- c) Indication of field of application (e.g. indoor use, explanation of the usage class).
- d) Indication that the free area shall be not less than 0,6 m greater than the training area in the directions from which the equipment is accessed. The free area must also include the area for emergency dismount. Where equipment is positioned adjacent to each other the value of the free area may be shared. The free area and training area shall be illustrated with a dedicated figure.
- e) Information on the correct use of the equipment and its features with the emphasis on safe operation, and the importance of keeping unsupervised children away from the equipment.
- f) Exercise instructions with advice with regard to correct biomechanical positioning of the user on the stationary training equipment. A warning indicating that injuries to health may result from incorrect or excessive training. Instructions shall be given in respect of every major exercise type for which the equipment is designed.
- g) Texts concerning difficult or complicated manoeuvres shall be accompanied by illustrations.
- h) Instruction on how to safely use access and escape assist means.
- i) Design illustration.
- j) Warning that if any of the adjustment devices are left projecting, they could interfere with the user's movement.
- k) Warning that free standing equipment shall be installed on a stable and levelled base.
- l) Setting of the load and equipment further adjustments (e.g. seat adjustments).
- m) Indication of the maximum user body mass.
- n) Indication of the maximum training mass, if applicable.
- o) Explanation of the displayed data, if applicable.
- p) If the heart rate is displayed, a warning with the following content shall be given: "WARNING! Heart rate monitoring systems may be inaccurate. Over exercising may result in serious injury or death. If you feel faint stop exercising immediately".

Test in accordance with [6.18](#).

5.18 Marking

Stationary training equipment shall be permanently marked with the following minimum information:

- a) name or trademark and full address of the manufacturer, supplier or importer;
- b) maximum body mass of user and the maximum training mass for the individual exercise stations (if applicable);
- c) usage classes S, H or I and accuracy classes A, B, C, which can be combined (e.g. SA) if both classes are specified in that part of this International Standard;
- d) individual code number (which contains information about type and year of manufacture);

- e) graphical symbol or written information in the national language(s) instructing the user to read the information supplied by the manufacturer;
- f) for class S and I equipment, a conspicuous graphical symbol or written information in the national language(s) shall be applied if the equipment needs attachment/anchoring for safe operation.

It is the responsibility of the manufacturer to display compliance with this International Standard by the additional indication of ISO 20957 in connection with the letter symbol of the designation class(es) (class S, H and I).

Test in accordance with [6.18](#).

6 Test methods

6.1 Test conditions

All testing shall be performed under the following conditions:

- a) temperature of $23\text{ °C} \pm 5\text{ °C}$;
- b) relative humidity of 55 % to 75 %.

6.2 Stability test

6.2.1 Test in training position

Place the equipment on a $(10_{-0}^{+2})^{\circ}$ incline surface, in the most onerous position.

Perform exercise(s) that involve(s) the user's mass, with the equipment loaded with a person weighing $(100 \pm 5)\text{kg}$, using the minimum as well as the maximum load, over the full range of exercise motion.

In addition, if applicable, perform exercise(s) that does not involve the user's mass, using the minimum as well as the maximum load, over the full range of exercise motion.

The equipment shall not tip over in either test.

The test person shall not lean or try to influence the balance of the machine.

6.2.2 Test in folded/storage position

Place equipment, folded according to the user's manual, on a $(10_{-0}^{+2})^{\circ}$ incline surface.

The equipment shall not tip over in either test.

6.3 External construction

6.3.1 Test of edges and corners

Test by measuring the radius and visual and tactile examination.

6.3.2 Tube ends

This test is a visual inspection of the unit to verify that all tube ends in the accessible hand and foot area are closed off.

The pull-out test shall be performed in a quasi static manner with an appropriate device.

6.3.3 Testing of squeeze and shear points and rotating and reciprocating points

Measure the minimum distance between two moving parts or a moving part and a fixed part.

6.3.4 Weights and resistant means

A performance test using the maximum and minimum resistance or weights including added resistance or weights (e.g. incremental weights) shall be carried out over the maximum range of movement.

6.3.5 Testing of pull-in points

Apparatus: test finger in accordance with [Figure 1](#). Surface hardness \geq HRC 40 (measured in accordance with ISO 6508-1).

Approach the pull-in point with the test finger probe to determine whether the test finger can become trapped. For non-protected pull-in points measure the pressure perpendicularly to the moving direction in the most onerous position of the mechanism (e.g. the rim of a pulley or the minimum radius of a cam). The test shall be performed with the maximum load. The pressure shall not exceed 90 N/cm^2 in any part of the mechanism.

6.4 Testing of entrapment

A visual and performance test shall be carried out to determine whether or not the user can become entrapped.

6.5 Adjustment components and locking mechanisms

Perform a visual and functional examination before, during and after every test.

6.6 Tensile test for ropes, belts, chains and attachment components

Measure the tension of the rope, belt or chain as well as the attachment components while statically applying the maximum specified load. Then perform a tensile test, with 6 times the maximum measured tension for the whole functional system.

6.7 Testing of rope and belt guides

Perform a functional test.

6.8 Testing of flywheels

Insert the test finger (see [Figure 1](#)) from all sides into any possible entrapment point between the drive and transmission elements, while the equipment is in normal operation.

Do not introduce the test finger beyond the edge of the protective covering.

Determine whether the test finger becomes trapped.

Dimensions in millimetres

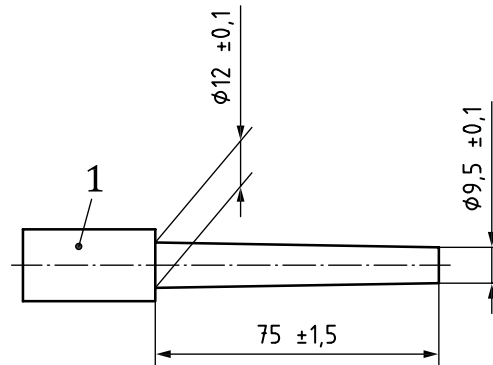
**Key**

1	handle
R_a -value	$\leq 0,40 \mu\text{m}$
Surface hardness	$\geq \text{HRC } 40$ (measured in accordance with ISO 6508-1)

Figure 1 — Test finger**6.9 Testing of integral handgrips**

Perform a functional test.

6.10 Determination of the removing force of applied handgrips

Apply a force of 70 N carefully to the handgrip by means of an appropriate pulling device.

6.11 Testing of rotating handgrips

Perform a functional test.

6.12 Testing of endurance load

Carry out the test as close as possible to normal exercise frequency and free of shocks for:

- a) class H 12 000 cycles over 80 % of the possible range of movement;
- b) class S 100 000 cycles over 80 % of the possible range of movement;
 - 1) with maximum load;
 - 2) in direction of load in accordance with the exercise instructions fixed by a 50 percentile man;
 - 3) with a frequency of movement in accordance with the user's manual.

If the equipment offers multiple exercise stations the test shall be done with all stations and functions as described in the user's manual.

6.13 Testing of isometric equipment

Measure the static output force or torque of the body in the position(s) as described in the user's manual and compare this value to the displayed value.

Perform the test using the following three values:

- minimum;

- maximum;
- a third random value between these two points.

6.14 Testing of the heart rate measurement system

Perform a visual test by using the heart rate measurement system.

6.15 Testing of the heart rate control mode

Set the equipment to the heart rate control mode with a target of 120 bpm. Operate the product according to the manufacturer's specifications, then use a heart rate simulator or a person to activate the control mode. Cut off the signal and then check if the resistance or the load reduces according to the requirements shown in 5.12. If there are more than one heart rate control system, each system shall be tested.

Test the heart rate indicator by visual testing.

6.16 Testing of intrinsic loading

Carry out the test quasi-statically. Apply the load F in the most onerous position when used according to the instructions in the user's manual on a surface area of 300 mm × 300 mm for 5 min on the stationary training equipment.

Only equipment that requires anchoring for normal use shall be fixed during the test.

6.17 Testing of extrinsic loading

Carry out the test quasi-statically. Apply the load F in the most onerous position when used according to the instructions in the user's manual for 5 min on the stationary training equipment. Place the determined load on the equipment as in normal practice and in a position which imposes greatest strain on the equipment.

When the load bearing surface is divided, apply the test load to each part in proportion to the total surface area at the same time.

The load should be applied through a load applicator in a way that simulates the situation that occurs when the equipment is used according to the instructions in the user's manual.

6.18 Testing of care and maintenance, assembly instructions, general instructions for use and marking

Verify the information provided by the manufacturer versus the equipment being tested.

6.19 Test report

The test report shall include at least the following information:

- a) name and address of the testing facility and location where the test was carried out when different from the address of the reporting facility;
- b) unique identification of the report (such as serial number), each page, and total number of pages of the report;
- c) name and address of the client;
- d) description and identification of the test item;
- e) date of receipt of the test item and date(s) of the performance of the test;
- f) identification of the test specification or description of the method or procedure;

- g) description of the sampling procedure, where relevant;
- h) any deviations, additions or exclusions from the test specification, and any other information relevant to a specific test;
- i) measurements, examinations and derived results, supported by tables, graphs, sketches and photographs as appropriate, and any failures identified;
- j) statement on the measurement uncertainty (where relevant);
- k) signature and title or an equivalent marking of person(s) accepting technical responsibility for the test report and date of issue;
- l) statement to the effect that the test results relate only to the items tested.

Bibliography

- [1] IFI/UK 1 04 04, EFDS Inclusive Fitness Initiative Equipment Standards – Stage 2 Edition 2 – May 2006
- [2] Directive 2006/121/EC (REACH) of the European Parliament and of the Council
- [3] Directive 2002/96/EC (WEEE) of the European Parliament and of the Council
- [4] Directive 2002/95/EC (ROHS) of the European Parliament and of the Council
- [5] Directive 2006/66/EC (Battery Directive) of the European Parliament and of the Council
- [6] Directive 2001/95/EC (General Product Safety Directive) of the European Parliament and of the Council
- [7] Directive 2006/95/EC (Low Voltage Directive) of the European Parliament and of the Council
- [8] Directive 2004/108/EC (EMC Directive) of the European Parliament and of the Council
- [9] Directive 2006/42/EC (Machinery Directive) of the European Parliament and of the Council
- [10] Directive 93/42/EEC (Medical Devices) of the European Parliament and of the Council
- [11] Directive 2009/125/EC (Energy related products) of the European Parliament and of the Council

.....

