

INTERNATIONAL STANDARD

ISO 20865

First edition
2002-07-01

Footwear — Test methods for outsoles — Compression energy

*Chaussures — Méthodes d'essai applicables aux semelles — Mesure de
l'énergie de compression*



Reference number
ISO 20865:2002(E)

© ISO 2002

PDF disclaimer

This PDF file may contain embedded typefaces. In accordance with Adobe's licensing policy, this file may be printed or viewed but shall not be edited unless the typefaces which are embedded are licensed to and installed on the computer performing the editing. In downloading this file, parties accept therein the responsibility of not infringing Adobe's licensing policy. The ISO Central Secretariat accepts no liability in this area.

Adobe is a trademark of Adobe Systems Incorporated.

Details of the software products used to create this PDF file can be found in the General Info relative to the file; the PDF-creation parameters were optimized for printing. Every care has been taken to ensure that the file is suitable for use by ISO member bodies. In the unlikely event that a problem relating to it is found, please inform the Central Secretariat at the address given below.

© ISO 2002

All rights reserved. Unless otherwise specified, no part of this publication may be reproduced or utilized in any form or by any means, electronic or mechanical, including photocopying and microfilm, without permission in writing from either ISO at the address below or ISO's member body in the country of the requester.

ISO copyright office
Case postale 56 • CH-1211 Geneva 20
Tel. + 41 22 749 01 11
Fax + 41 22 749 09 47
E-mail copyright@iso.ch
Web www.iso.ch

Printed in Switzerland

Foreword

ISO (the International Organization for Standardization) is a worldwide federation of national standards bodies (ISO member bodies). The work of preparing International Standards is normally carried out through ISO technical committees. Each member body interested in a subject for which a technical committee has been established has the right to be represented on that committee. International organizations, governmental and non-governmental, in liaison with ISO, also take part in the work. ISO collaborates closely with the International Electrotechnical Commission (IEC) on all matters of electrotechnical standardization.

International Standards are drafted in accordance with the rules given in the ISO/IEC Directives, Part 3.

The main task of technical committees is to prepare International Standards. Draft International Standards adopted by the technical committees are circulated to the member bodies for voting. Publication as an International Standard requires approval by at least 75 % of the member bodies casting a vote.

Attention is drawn to the possibility that some of the elements of this International Standard may be the subject of patent rights. ISO shall not be held responsible for identifying any or all such patent rights.

International Standard ISO 20865 was prepared by CEN (as EN 12743:1999) and was adopted, under a special "fast-track procedure", by Technical Committee ISO/TC 216, *Footwear*, in parallel with its approval by the ISO member bodies.

This International Standard incorporates Corrigendum EN 12743:1999/AC.

For the purposes of international standardization, a list of corresponding International and European Standards for which equivalents are not given in EN 12743 has been added as annex ZZ.

Contents

	Page
Foreword	3
1 Scope	4
2 Normative references	4
3 Definitions	4
4 Apparatus and material	4
5 Sampling and conditioning	5
6 Test method	5
7 Expression of results	5
8 Test Report	6
Bibliography	8

Foreword

This European Standard has been prepared by Technical Committee CEN/TC 309 "Footwear", the secretariat of which is held by AENOR.

This European Standard shall be given the status of a national standard, either by publication of an identical text or by endorsement, at the latest by March 2000, and conflicting national standards shall be withdrawn at the latest by March 2000.

According to the CEN/CENELEC Internal Regulations, the national standards organizations of the following countries are bound to implement this European Standard: Austria, Belgium, Czech Republic, Denmark, Finland, France, Germany, Greece, Iceland, Ireland, Italy, Luxembourg, Netherlands, Norway, Portugal, Spain, Sweden, Switzerland and the United Kingdom.

© 2008 International Organization for Standardization

1 Scope

This European standard specifies a method for the determination of the compression energy of outsoles.

2 Normative references

This European Standard incorporates by dated or undated reference, provisions from other publications. These normative references are cited at the appropriate places in the text and the publications are listed hereafter. For dated references, subsequent amendments to or revisions of any of these publications apply to this European Standard only when incorporated in it by amendment or revision. For undated references the latest edition of the publication referred to applies.

EN 12222	Footwear - Standard atmospheres for conditioning and testing of footwear and components for footwear
prEN 13400:1998	Footwear - Sampling location of components for footwear.
ISO 5893	Rubber and plastic test equipment - Tensile, flexural and compression types (constant rate of traverse) - Description.

3 Definitions

For the purpose of this standard the following definition applies:

Compression energy:

The energy in joules corresponding to the deformation of a material under a fixed force of 5000 newtons.

4 Apparatus and material

The following apparatus and material shall be used:

4.1 Tensile-testing machine

The tensile-testing machine shall comply with the requirements of ISO 5893, to an accuracy corresponding to grade B, with a constant rate of traverse of 10 mm/min \pm 2 mm/min. A low-inertia machine having autographic force recording facilities is required.

4.2 Test punch, being the back part of a standardized last made in polyethylene. The last is sectioned on a plane vertical to the feather edge and at 90° to the axis of the back part (see figure 1). The length of the punch in relation to footwear size is given in table 1.

Table 1
Summarising chart of measurements for footwear

SIZE			DIMENSIONS				
MONDOPOINT (mm)	FRENCH SIZES	ENGLISH SIZES	L mm	l mm	H mm	h mm	D mm
up to 235	up to 36	up to 3	65,0 ± 1	32,5 ± 1	60 ± 1	40 ± 1	14 ± 0,5
up to 245	37/38	4/5	67,5 ± 1	33,7 ± 1	60 ± 1	40 ± 1	14 ± 0,5
up to 255	39/40	6	70,5 ± 1	35,0 ± 1	60 ± 1	40 ± 1	14 ± 0,5
up to 265	41/42	7/7,5/8	72,5 ± 1	36,2 ± 1	60 ± 1	40 ± 1	14 ± 0,5
up to 275	43/44	9/10	75,5 ± 1	37,7 ± 1	60 ± 1	40 ± 1	14 ± 0,5
up to 285	45 and over	11 and over	77,5 ± 1	38,5 ± 1	60 ± 1	40 ± 1	14 ± 0,5

5 Sampling and conditioning

Test specimens to be tested are taken in accordance with prEN 13400:1998. All test specimens shall be conditioned in accordance with EN 12222 before testing.

Minimum time of conditioning 24 hours, and minimum two test pieces by size are necessary.

6 Test method

Place the outsole with the heel on a steel base and press the test punch against the outsole unit from the inside at the centre of the heel area at a test rate of 10 mm/min ± 3mm/min until a force of 5 000 newtons is obtained.

7 Expression of results

Plot a load/compression curve (see figure 2) for each test and determine the compression energy E in joules, rounded to the nearest 1 J, from the equation:

$$E = \int F \cdot ds$$

where

F is the applied force, in newtons

s is the deformation, in metres

The result will be expressed as the average value.

8 Test Report

The test report shall include the following information:

- a) results, expressed in accordance with clause 7;
- b) full identification of the sample;
- c) reference to this method of test;
- d) date of testing.

Dimensions in mm

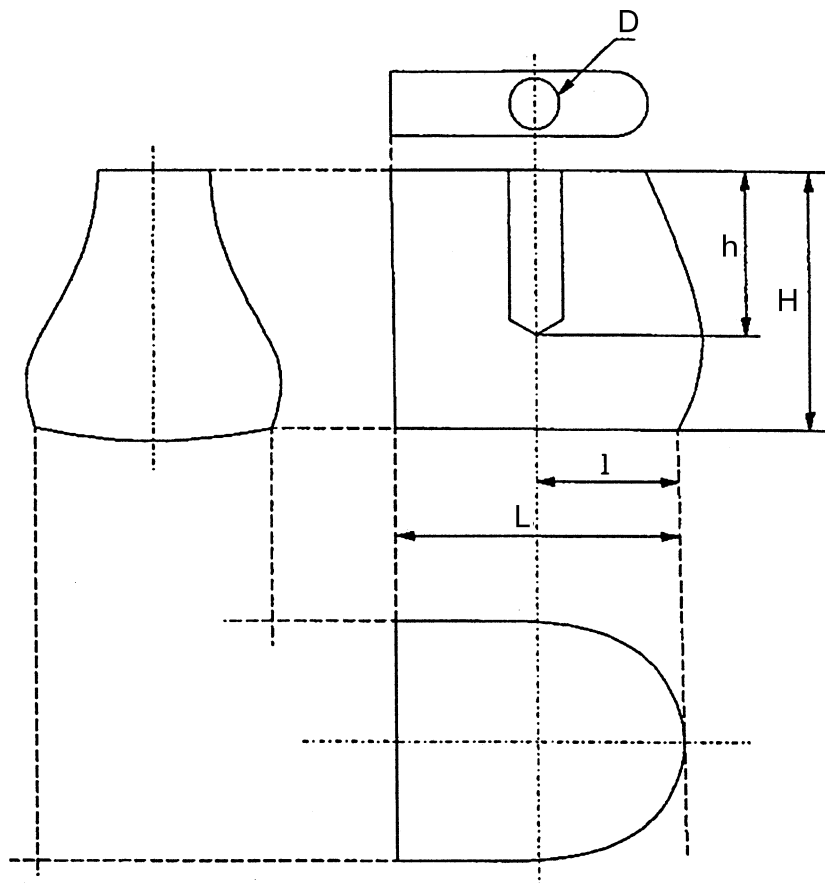
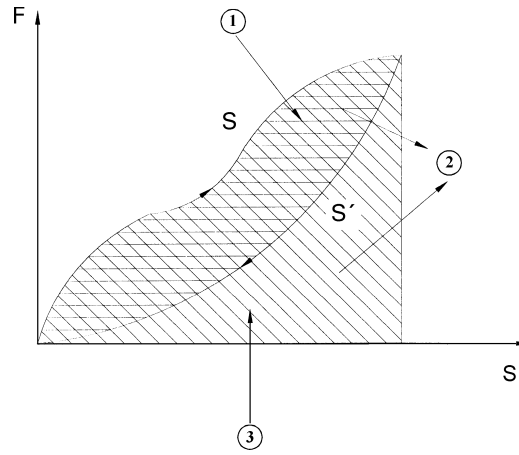

Figure 1 - Test punch for compression energy test



1 Absorption Energy (S-S'): Hysteresis. The difference between S and S'

2 Compression Energy (E): The energy in joules corresponding to the cycle of the material from 50 N to 5000 N

3 Elastic Energy (S'): The energy in joules corresponding to the return cycle of the material from 5000 N to 0 N

Figure 2

Bibliography

- EN 344 Requirements and test methods for safety, protective and occupational footwear for professional use.

Annex ZZ
(informative)

**List of International Standards identical to the European Standards
referenced in Clause 2**

European Standard	International Standard
EN 12222:1997	ISO 18454
EN 13400:2001 ^b	ISO 17709 ^a
^a To be published. ^b Published as an EN in November 2001.	

ICS 61.060

Price based on 6 pages

© ISO 2002 – All rights reserved