

---

---

**Ergonomics — 3-D scanning  
methodologies for internationally  
compatible anthropometric  
databases —**

**Part 2:  
Evaluation protocol of surface  
shape and repeatability of relative  
landmark positions**

*Ergonomie — Méthodologies d'exploration tridimensionnelles  
pour les bases de données anthropométriques compatibles au plan  
international —*

*Partie 2: Protocole d'évaluation de la forme extérieure et de la  
répétabilité des positions relatives de repères*





**COPYRIGHT PROTECTED DOCUMENT**

© ISO 2015, Published in Switzerland

All rights reserved. Unless otherwise specified, no part of this publication may be reproduced or utilized otherwise in any form or by any means, electronic or mechanical, including photocopying, or posting on the internet or an intranet, without prior written permission. Permission can be requested from either ISO at the address below or ISO's member body in the country of the requester.

ISO copyright office  
Ch. de Blandonnet 8 • CP 401  
CH-1214 Vernier, Geneva, Switzerland  
Tel. +41 22 749 01 11  
Fax +41 22 749 09 47  
copyright@iso.org  
www.iso.org

# Contents

Page

<b>Foreword</b> .....	<b>iv</b>
<b>Introduction</b> .....	<b>v</b>
<b>1 Scope</b> .....	<b>1</b>
<b>2 Normative references</b> .....	<b>1</b>
<b>3 Terms and definitions</b> .....	<b>1</b>
<b>4 Test protocol for evaluating surface shape measurement</b> .....	<b>3</b>
4.1 General aspects .....	3
4.2 Test sphere .....	3
4.3 Procedure .....	3
4.3.1 Measurement of test sphere .....	3
4.3.2 Calculation of quality parameters .....	4
4.3.3 Report .....	4
<b>5 Test protocol for evaluating repeatability of landmark positions</b> .....	<b>5</b>
5.1 General aspects .....	5
5.2 Test object .....	5
5.3 Landmarks .....	5
5.4 Procedure .....	6
5.4.1 Measurement .....	6
5.4.2 Calculation of quality parameter .....	7
5.4.3 Report .....	7
<b>6 Evaluation of hidden area</b> .....	<b>7</b>
6.1 General aspect .....	7
6.2 Recruitment of subjects .....	7
6.3 Posture control and measurement .....	7
6.4 Procedure to evaluate the hidden area .....	8
6.5 Report .....	8
<b>Annex A (informative) Sample of test object</b> .....	<b>9</b>
<b>Annex B (informative) Example of test and report</b> .....	<b>11</b>
<b>Annex C (informative) Example of report of evaluation of hidden area</b> .....	<b>17</b>
<b>Annex D (informative) Simultaneous superimposition of landmark coordinate data from 10 scans</b> .....	<b>19</b>
<b>Bibliography</b> .....	<b>20</b>

## Foreword

ISO (the International Organization for Standardization) is a worldwide federation of national standards bodies (ISO member bodies). The work of preparing International Standards is normally carried out through ISO technical committees. Each member body interested in a subject for which a technical committee has been established has the right to be represented on that committee. International organizations, governmental and non-governmental, in liaison with ISO, also take part in the work. ISO collaborates closely with the International Electrotechnical Commission (IEC) on all matters of electrotechnical standardization.

The procedures used to develop this document and those intended for its further maintenance are described in the ISO/IEC Directives, Part 1. In particular the different approval criteria needed for the different types of ISO documents should be noted. This document was drafted in accordance with the editorial rules of the ISO/IEC Directives, Part 2 (see [www.iso.org/directives](http://www.iso.org/directives)).

Attention is drawn to the possibility that some of the elements of this document may be the subject of patent rights. ISO shall not be held responsible for identifying any or all such patent rights. Details of any patent rights identified during the development of the document will be in the Introduction and/or on the ISO list of patent declarations received (see [www.iso.org/patents](http://www.iso.org/patents)).

Any trade name used in this document is information given for the convenience of users and does not constitute an endorsement.

For an explanation on the meaning of ISO specific terms and expressions related to conformity assessment, as well as information about ISO's adherence to the WTO principles in the Technical Barriers to Trade (TBT) see the following URL: [Foreword - Supplementary information](#)

The committee responsible for this document is ISO/TC 159, *Ergonomics*, Subcommittee SC 3, *Anthropometry and biomechanics*.

ISO 20685 consists of the following parts, under the general title *3-D scanning methodologies for internationally compatible anthropometric databases*:

— *Part 2: Evaluation protocol of surface shape and repeatability of relative landmark positions*

A revision of ISO 20685:2010 is under preparation; when revised, it will become

— *Part 1: Evaluation protocol for body dimensions extracted from 3-D body scans*

## Introduction

Anthropometric measures are key to many International Standards. These measures can be gathered using a variety of instruments. An instrument with relatively new application to anthropometry is a three-dimensional (3-D) scanner. 3-D scanners generate a 3-D point cloud of the outside of the human body that can be used in a number of situations including clothing and automotive design, engineering and medical applications. Recently, digital human models are created from a 3-D point cloud, and used for various applications related to technological design process. Quality control of scan-extracted anthropometric data is important since required quality can differ according to applications.

There are a number of different fundamental technologies that underlie commercially available systems. These include stereophotogrammetry, ultrasound and light (laser light, white light and infrared), among others. Further, the software that is available to process data from the scan varies in its methods. Additionally, methods to extract landmark positions are different between commercially available systems. In some systems, anthropometrists decide landmark locations and paste marker stickers, and scanner system calculate locations of marker stickers and identify their names, while in other systems, landmark positions are automatically calculated from the surface shape data. Quality of landmark locations have significant effects on the quality of scan-extracted 1-D measurements as well as digital human models created based on these landmarks.

As a result of differences in fundamental technology, hardware and software, the quality of body surface shape and landmark locations from several different systems can be different for the same individual. Since 3-D scanning can be used to gather these data, it was important to develop an International Standard that allows users of such systems as well as users of scan-extracted measurements to judge whether the 3-D system is adequate for these needs.

The intent of this part of ISO 20685 is to ensure the quality control process of body scanners, especially that of surface shape and locations of landmarks as specified by ISO 7250-1.



# Ergonomics — 3-D scanning methodologies for internationally compatible anthropometric databases —

## Part 2: Evaluation protocol of surface shape and repeatability of relative landmark positions

### 1 Scope

This part of ISO 20685 addresses protocols for testing of 3-D surface-scanning systems in the acquisition of human body shape data and measurements. It does not apply to instruments that measure the motion of individual landmarks.

While mainly concerned with whole-body scanners, it is also applicable to body-segment scanners (head scanners, hand scanners, foot scanners). This International Standard applies to body scanners that measure the human body in a single view. When a hand-held scanner is evaluated, it has to be noted that the human operator can contribute to the overall error. When systems are evaluated in which the subject is rotated, movement artefacts can be introduced; these can also contribute to the overall error. This part of ISO 20685 applies to the landmark positions determined by an anthropometrist. It does not apply to landmark positions automatically calculated by software from the point cloud.

The quality of surface shape of the human body and landmark positions is influenced by performance of scanner systems and humans including measurers and subjects. This part of ISO 20685 addresses the performance of scanner systems by using artefacts rather than human subjects as test objects.

Traditional instruments are required to be accurate to millimetre. Their accuracy can be verified by comparing the instrument with a scale calibrated according to an international standard of length. To verify or specify the accuracy of body scanners, a calibrated test object with known form and size is used.

The intended audience is those who use 3-D body scanners to create 3-D anthropometric databases including 3-D landmark locations, the users of these data, and scanner designers and manufacturers. This part of ISO 20685 intends to provide the basis for the agreement on the performance of body scanners between scanner users and scanner providers as well as between 3-D anthropometric database providers and data users.

### 2 Normative references

The following documents, in whole or in part, are normatively referenced in this document and are indispensable for its application. For dated references, only the edition cited applies. For undated references, the latest edition of the referenced document (including any amendments) applies.

ISO 7250-1, *Basic human body measurements for technological design — Part 1: Body measurement definitions and landmarks*

ISO 10360-8, *Geometrical product specifications (GPS) — Acceptance and reverification tests for coordinate measuring systems (CMS) — Part 8: CMMs with optical distance sensors*

ISO 20685, *3-D scanning methodologies for internationally compatible anthropometric databases*

### 3 Terms and definitions

For the purposes of this document, the following terms and definitions apply.

**3.1 error of spherical form measurement**

error within the range of the Gaussian radial distance, determined by a least-squares fit of measured data points on a test sphere

Note 1 to entry: Error of spherical form measurement is associated with the performance of the body scanner and the sphericity of the test sphere.

**3.2 spherical form dispersion value**

smallest width of a spherical shell that includes  $n$  % of all the measured data points

Note 1 to entry: See [Figure 1](#), right.

Note 2 to entry:  $n$  should be 90 %.

**3.3 standard deviation of radial distances**

standard deviation of radial distances from measured data points and best-fit sphere

Note 1 to entry: Standard deviation of radial distances is an indicator of error of spherical form measurement and is highly correlated with error of spherical form measurement (90 %).

**3.4 error of diameter measurement**

error of the diameter of a least-squares fit of measured data points on a test sphere

Note 1 to entry: See [Figure 1](#), left.

Note 2 to entry: It is calculated as the measured diameter minus the calibrated diameter.

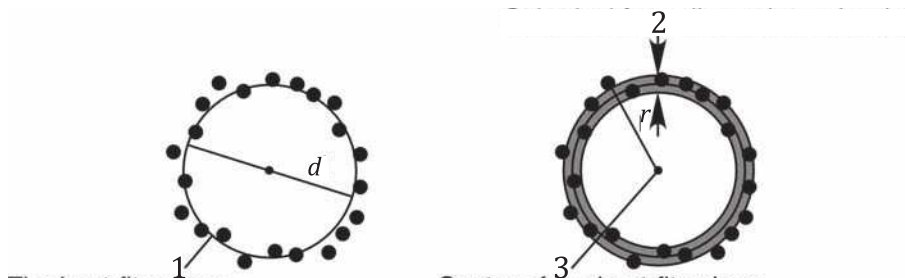

**Key**

- 1 best-fit sphere
- 2 spherical form dispersion value ( $n$ )
- 3 centre of the best-fit sphere
- $d$  diameter of the best-fit sphere
- $r$  radial distance of a measured data point from the centre of the best-fit sphere

NOTE Spherical form dispersion value ( $n$ ), in which  $n$  % of the measured data points are located, is shown as the radial thickness of the shaded area of the right figure. Spherical form dispersion value ( $n$ ) is calculated as the  $100 - n/2$  percentile value minus  $n/2$  percentile value of the radial distances of the measured data points from the centre of the best-fit sphere.

**Figure 1 — Error of diameter measurement and spherical form dispersion value**



## 4 Test protocol for evaluating surface shape measurement

### 4.1 General aspects

The environmental conditions shall correspond to the operating conditions of the 3-D body scanner. When operation mode needs to be modified to measure the test object, it shall be specified in the report.

### 4.2 Test sphere

Sphere made of steel, ceramic, or other suitable materials with diffusely reflecting surface are used to determine the quality parameter spherical form dispersion value and error of diameter measurement. It is desirable that the diameter of the sphere should be larger than 10 % of the largest dimension of a rectangular parallelepiped scanning volume.

The diameter and form of the test sphere shall be calibrated, and a calibration certificate shall be available. Since the form deviation and the roughness of the test sphere influence the test results, error of spherical form measurement in the certificate shall be smaller than one fifth of the maximum permissible error determined by the body scanner manufacturer.

The surface properties of the test sphere may significantly affect the test results. The material of test sphere shall be reported.

The reference sphere supplied with the body scanner for the calibration purposes shall not be used for this test.

Example of sphere is shown in [Annex A](#).

### 4.3 Procedure

#### 4.3.1 Measurement of test sphere

The sphere shall be measured at least nine different positions within the scanning volume. Measurement positions shall include the following nine positions ([Figure 2](#)): position 1 is the centre of the scanning volume on the floor; position 2 to position 5 are 500 mm, 1 000 mm, 1 500 mm, and 2 000 mm off the floor, above position 1; position 6 and position 7 are 250 mm anterior to or posterior to the centre position and 1 000 mm off the floor; position 8 and position 9 are 400 mm right or left to the centre position and 1 000 mm off the floor.

When the sphere cannot be measured at positions described above due to a smaller scanning volume, measure the sphere at a position closest to the intended position, and record the exact position.

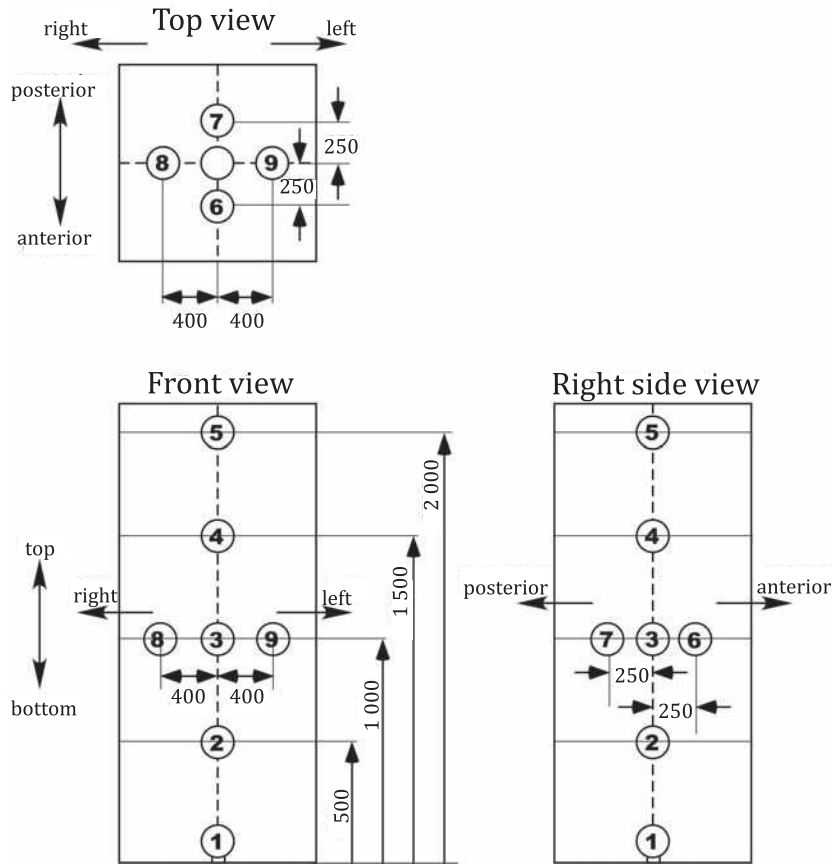

Figure 2 — Measurement positions of the sphere

#### 4.3.2 Calculation of quality parameters

Data points from objects other than the test sphere, such as a tripod, shall be deleted manually. Outlying data points due to reflection can be also removed.

Centre of a best-fit sphere is calculated from the measured data points. Calculate radial distances from the centre of the best-fit sphere to all data points. The diameter of the best-fit sphere is calculated as the mean of all radial distances.

Error of diameter measurement is calculated as the diameter of the best-fit sphere minus the calibrated diameter.

Spherical form dispersion value (90 %) is calculated as 95 percentile value minus 5 percentile value of the radial distances.

Standard deviation of all radial distances shall be calculated.

#### 4.3.3 Report

Material and calibration results of test sphere (diameter and probing dispersion value) shall be reported.

For each position, actual measurement position, error of diameter measurement, spherical form dispersion value (90 %), and standard deviation of radial distances from measured data points and the best-fit sphere shall be reported. Figures of measured data points of test sphere help interpreting results.

Example of test procedure and report are shown in [Annex B](#).

## 5 Test protocol for evaluating repeatability of landmark positions

### 5.1 General aspects

The environmental conditions shall correspond to the operating conditions of the 3-D body scanner. When operation mode needs to be modified to measure the test object, it shall be specified in the report.

### 5.2 Test object

An anthropomorphic dummy representing the size and shape of a natural human, rather than an idealized human, shall be used. It is desirable that the dummy has no movable parts, and the posture recommended in ISO 20685 for circumferences. It is further desirable that it be made of FRP (fibre reinforced plastics), metal or other suitable materials with a diffuse reflecting surface. The landmarks to be evaluated should be premarked on the dummy.

An example of dummy is shown in [Annex A](#).

### 5.3 Landmarks

Landmarks to be evaluated are listed in [Table 1](#). Among the 47 landmarks, #1 to #29 are defined in ISO 20685, and shall be evaluated. Landmarks #30 to #47 are optional. When landmarks other than those listed in [Table 1](#) need to be evaluated, these landmarks are numbered from #48.

Before measurement, marker stickers are pasted on landmark positions to be evaluated. Marker stickers should be chosen to be appropriate for the scanner being tested.

**Table 1 — Landmarks to be evaluated**

#	Landmark	Clause # in ISO 20685
1	Vertex (top of head)	3.30
2	Tragion, right	3.31
3	Tragion, left	3.31
4	Infraorbitale, right	3.15
5	Infraorbitale, left	3.15
6	Glabella	3.13
7	Sellion	3.24
8	Menton	3.18
9	Opisthocranion	3.20
10	Cervicale	3.10
11	Acromion, right	3.6
12	Acromion, left	3.6
13	Mesosternale	3.19
14	Thelion, right	3.27
15	Thelion, left	3.27
16	Iliocristale, right	3.14
17	Iliocristale, left	3.14
18	Anterior superior iliac spine, right	3.8
19	Anterior superior iliac spine, left	3.8
20	Stylian, right	3.25
21	Stylian, left	3.25

**Table 1** (continued)

#	Landmark	Clause # in ISO 20685
22	Ulnar stylium, right	3.33
23	Ulnar stylium, left	3.33
24	Tibiale, right	3.29
25	Tibiale, left	3.29
26	Lateral malleolus, right	3.16
27	Lateral malleolus, left	3.16
28	Suprapatella, right	3.26
29	Suprapatella, left	3.26
30	Neck shoulder point, right	Optional
31	Neck shoulder point, left	Optional
32	Front neck point	Optional
33	Anterior axilla point, right	Optional
34	Anterior axilla point, left	Optional
35	Posterior axilla point, right	Optional
36	Posterior axilla point, left	Optional
37	Omphalion	Optional
38	Trochanterion, right	Optional
39	Trochanterion, left	Optional
40	Buttock point, right	Optional
41	Buttock point, left	Optional
42	Radiale, right	Optional
43	Radiale, left	Optional
44	Mid patella, right	Optional
45	Mid patella, left	Optional
46	Sphyrion, right	Optional
47	Sphyrion, left	Optional

## 5.4 Procedure

### 5.4.1 Measurement

The dummy shall be scanned 10 times. After each scan, dummy shall be slightly moved to simulate the variation in the standing position of human subjects. Variation in position shall include antero-posterior and lateral translations and rotational differences. The 10 positions shown in [Table 2](#) are recommended.

**Table 2 — Recommended positions to scan the dummy**

#	Position
1	The base position, the position where human subjects stand
2	10 mm anterior to the base position
3	10 mm posterior to the base position
4	10 mm right to the base position
5	10 mm left to the base position

Table 2 (continued)

#	Position
6	Rotate counter-clockwise: place only the right heel anterior to the base position by 10 mm
7	Rotate clockwise: place only the left heel anterior to the base position by 10 mm
8	10 mm anterior to the base position, and rotate counter-clockwise as position #6
9	10 mm posterior to the base position, and rotate clockwise as position #7
10	The base position

#### 5.4.2 Calculation of quality parameter

Landmark coordinates are obtained for each scan using available method.

Only those landmarks that can be obtained from all 10 scans are used to calculate quality parameters. The 10 landmark position data are superimposed simultaneously. See [Annex D](#) for an example of procedure.

After the superimposition, for each landmark, the error is calculated as the distance between corresponding landmark positions for all possible pairs of landmark position data ( $N = {}_{10}C_2 = 45$ ). For each landmark, mean error and maximum errors are calculated as the quality parameters.

[Annex D](#) explains methods of simultaneous superimposition of landmark data obtained from 10 scans.

#### 5.4.3 Report

Material, size, posture, colour, and other relevant information of the anthropomorphic dummy used shall be described.

Evaluated landmarks shall be reported. For each landmark, number of scans for which landmark position could be calculated, mean error, and standard deviation of errors shall be reported.

Example of the test procedure and report is shown in [Annex B](#).

## 6 Evaluation of hidden area

### 6.1 General aspect

There are several aspects of quality of human body shape data that cannot be evaluated using a dummy, because dummies might not represent the population of interest, and the available body shapes are limited. One of the most important aspects that affects the quality of surface shape and landmark positions is the hidden area, a part of the body that cannot be measured because of the occlusion by other part(s) of the body. Hidden area depends on the body shape. Therefore, actual humans should be used to evaluate the hidden area, as well as to verify that the scanner can accommodate the population of interest.

### 6.2 Recruitment of subjects

Scans from more than one subject should be used. It is desirable to select subjects to represent the shape variability of the population of interest. This might include some combination of male and female participants that are small (e.g. 5th percentile) and large (e.g. 95th percentile) by stature and BMI, or it might include people with various disabilities.

### 6.3 Posture control and measurement

The subject takes the posture for circumference measurement recommended in ISO 20685. The subject is scanned once according to usual scanning procedure.

#### 6.4 Procedure to evaluate the hidden area

Measured data after ordinal data processing of the body scanner system should be displayed as the surface polygon without smooth shading. Some body scanners automatically fill gaps or holes before visualization. If possible, do not use such function. If this is impossible, report it.

The operator checks the lack of surface data as the hidden area by eye inspection. The standard area code of the hidden area should be recorded. [Table 3](#) shows the area code. Other areas can be added when necessary.

**Table 3 — Recommended positions to scan the dummy**

Code number	Area
10	Top of the head
11	Under the nose
12	Back of the ear
13	Pupil
14	Under the chin
20	Over the shoulder
21	Armpit and the trunk
22	Under the bust
23	Under the buttocks
24	Under the crotch and the medial side of the thighs
25	Side of the body, arms, and legs
30	Trunk side of the arm
40	The plantar part of the foot

#### 6.5 Report

Mean, minimum, and maximum values of the body height, body mass, and BMI of the subjects should be reported. Number of subjects with hidden area for each area should be reported. Images of gaps or holes will help interpreting results.

Example of report is shown in [Annex C](#).

## Annex A (informative)

### Sample of test object

#### A.1 Sphere

A sample sphere shown in [Figure A.1](#) is made of hollow steel with TiN coating. It was calibrated using CMM. The diameter is 120,01593 mm, and spherical form dispersion value (100 %) is 0,01896 mm.

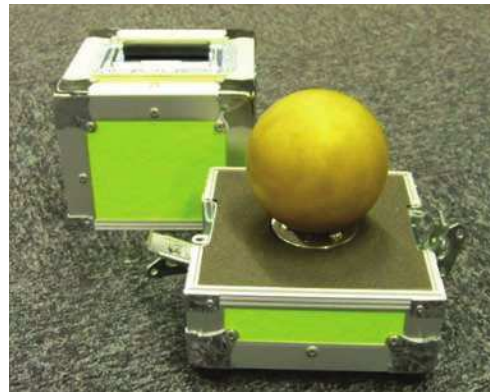

Figure A.1 — Sample sphere

#### A.2 Dummy

A sample anthropomorphic dummy shown in [Figure A.2](#) is made of fibre reinforced plastics (FRP). It has mean body dimensions of young adult Japanese females. Landmark positions are marked with small dents. It takes the posture for circumference measurements recommended in ISO 20685.



**Figure A.2 — Sample anthropomorphic dummy**



## Annex B (informative)

### Example of test and report

#### B.1 Evaluation of shape measurement

##### B.1.1 General

A whole body scanner was evaluated according to the protocol described in this part of ISO 20685.

##### B.1.2 Test object

Test sphere shown in A.1 was used. Material was steel. Surface was blasted and TiN treated. Surface colour is mat gold. The test sphere was calibrated in National Metrology Institute of Japan. Diameter was 120,01593 mm. Spherical form dispersion value (100 %) calculated as the difference between the maximum and minimum radial distances was 0,01896 mm.

##### B.1.3 Procedure

The sphere was measured at positions #1 to #4 and #6 to #9. Since the height of the scanning volume was too small to measure the sphere at position #5, the sphere was measured at the height of 1 900 mm instead of 2 000 mm.

Best-fit sphere was calculated for the measured point cloud after removing data points not belonging to the sphere. Software developed for this purpose was used. Error of diameter measurement, spherical form dispersion value, and standard deviation of radial distances were calculated.

##### B.1.4 Report

Results are tabulated in [Table B.1](#) as a report.

**Table B.1 — Example report of the evaluation test of surface shape measurement**

Name of body scanner (Name of manufacturer)	Bodyline scanner C9036-02 (Hamamatsu photonics)
Evaluated by	Digital Human Research Center, National Institute of Advanced Industrial Science and Technology (AIST)
Date of test	26 May, 2009
Place of test	Digital Human Research Center, AIST, 2-3-26 Aomi Koto-ku, Tokyo 135-0064, Japan
1. Test object (Sphere)	
Material	Steel
Surface treatment	Blasted and TiN treated
Calibrated by	National Metrology Institute of Japan, AIST
Diameter	120,01593 mm
Spherical form dispersion value (100 %)	0,01896 mm
2. Results	

**Table B.1** (continued)

Position		Error of diameter measurement (mm)	Spherical form dispersion value (90 %) (mm)	Standard deviation of radial distances (mm)
1	Same with specification	1,867	6,004	1,854
2	Same with specification	-0,303	2,164	0,682
3	Same with specification	1,447	3,311	1,035
4	Same with specification	3,344	3,391	4,039
5	Height was 1 900 mm	1,484	5,214	1,622
6	Same with specification	1,180	3,937	1,226
7	Same with specification	2,291	10,326	3,156
8	Same with specification	0,167	6,384	2,055
9	Same with specification	2,515	7,338	2,080

3. Figures of measured test sphere

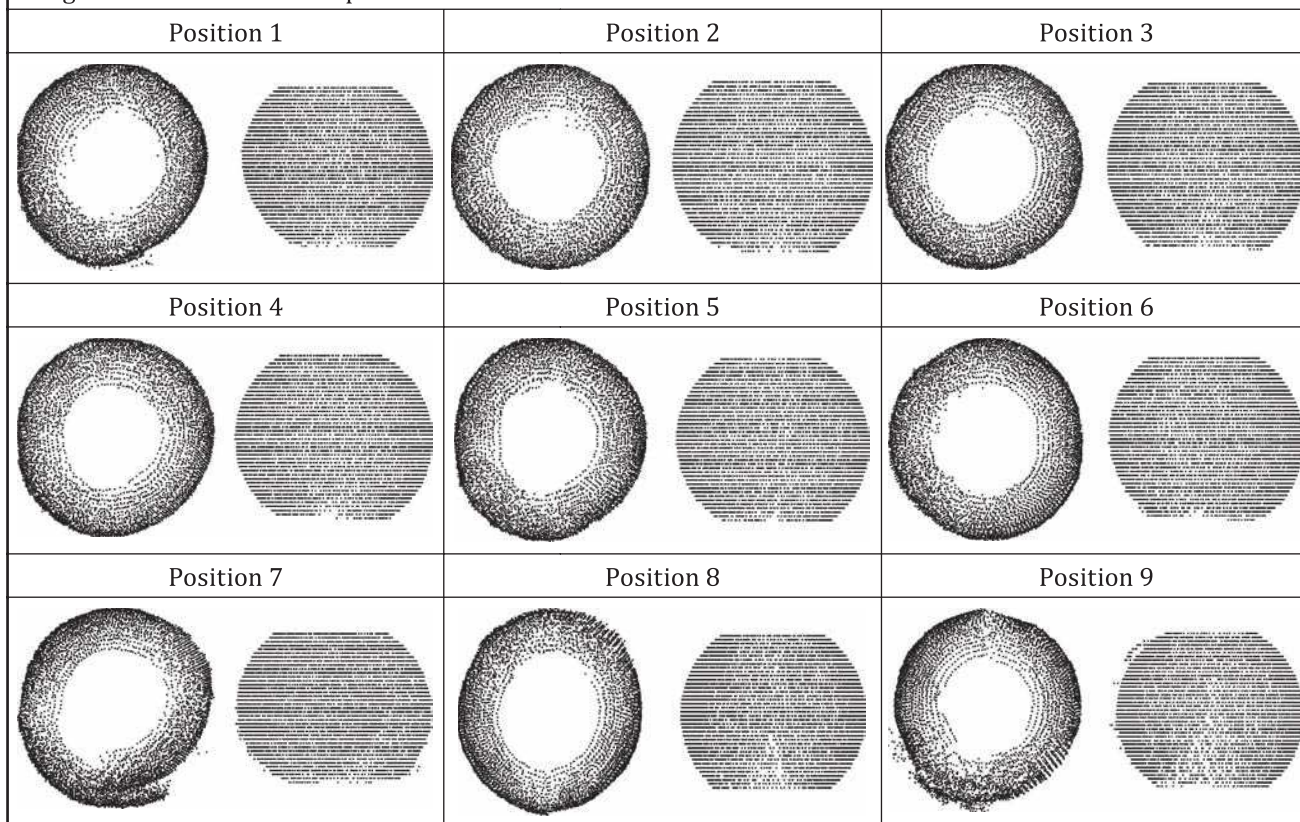

**B.2 Evaluation of repeatability of landmark positions**

**B.2.1 General**

A whole body scanner was evaluated according to the protocol described in this part of ISO 20685.

**B.2.2 Test object**

Anthropomorphic dummy shown in A.2 was used. Material was FRP. Surface colour is grey. The surface diffuses the light. It takes the posture for circumference measurements recommended in ISO 20685. It has body dimensions of average Japanese females aged 20 years to 29 years. Landmark positions are marked with small dents.

### B.2.3 Procedure

Marker stickers specific to the body scanner were pasted on positions of 47 landmarks listed in [Table 1](#).

In this body scanner, the foot position is specified on the platform. A line was drawn on the platform to define the heel position. The dummy was measured 10 times at recommended positions shown in [Table 2](#).

In this body scanner, positions of marker stickers are automatically detected and coordinates of landmark positions are calculated. Landmarks are and automatically labelled. Landmark names were examined, and corrected when necessary.

Obtained landmark positions were examined, and landmarks with coordinates from all 10 scans were used for further analysis.

Landmark position data from 10 scans were superimposed simultaneously, and after the superimposition, distance between corresponding landmarks was calculated for each landmark and for all possible pairs of 10 scans. Software developed for this purpose was used.

Mean and standard deviation of errors were calculated using Excel.

### B.2.4 Report

Results are tabulated in [Table B.2](#) as a report.

**Table B.2 — Example report of the evaluation test of landmark repeatability**

Name of body scanner (Name of manufacturer)	Bodyline scanner C9036-02 (Hamamatsu photonics)	
Evaluated by	Digital Human Research Center, National Institute of Advanced Industrial Science and Technology (AIST)	
Date of test	26 May, 2009	
Place of test	Digital Human Research Center, AIST, 2-3-26 Aomi Koto-ku, Tokyo 135-0064, Japan	
1. Test object (Anthropomorphic dummy)		
Material	FRP	
Surface treatment	Colour is grey, diffuse the light. Landmark positions are marked with small dents.	
Size	The dummy has average body dimensions of Japanese females aged 20 years to 29 years. Body height is 1 580 mm	
Manufacturer	Nanasai Co. Ltd.	
Number of tested landmarks	47 landmarks listed below	
2. Results		
1) Number of scans in which coordinates could be calculated		
#	Landmark	Number of scans
1	Vertex (top of head) [automatically calculated position]	10
2	Tragion, right	10
3	Tragion, left	2
4	Infraorbitale, right	10
5	Infraorbitale, left	10
6	Glabella	8
NOTE #1 Vertex (top of head) was excluded from analysis because it was automatically calculated rather than calculated from the marker position.		

**Table B.2** (continued)

7	Sellion	2
8	Menton	0
9	Opisthocranion	10
10	Cervicale	10
11	Acromion, right	1
12	Acromion, left	7
13	Mesosternale	10
14	Thelion, right	10
15	Thelion, left	10
16	Iliocristale, right	10
17	Iliocristale, left	10
18	Anterior superior iliac spine, right	10
19	Anterior superior iliac spine, left	10
20	Stylian, right	10
21	Stylian, left	8
22	Ulnar stylian, right	10
23	Ulnar stylian, left	10
24	Tibiale, right	10
25	Tibiale, left	10
26	Lateral malleolus, right	0
27	Lateral malleolus, left	0
28	Suprapatella, right	10
29	Suprapatella, left	10
30	Neck shoulder point, right	10
31	Neck shoulder point, left	10
32	Front neck point	10
33	Anterior axilla point, right	10
34	Anterior axilla point, left	10
35	Posterior axilla point, right	10
36	Posterior axilla point, left	4
37	Omphalion	10
38	Trochanterion, right	10
39	Trochanterion, left	10
40	Buttock point, right	10
41	Buttock point, left	10
42	Radiale, right	10
43	Radiale, left	10
44	Mid patella, right	10
45	Mid patella, left	10
46	Sphyrion, right	0

NOTE #1 Vertex (top of head) was excluded from analysis because it was automatically calculated rather than calculated from the marker position.

Table B.2 (continued)

47	Sphyrion, left			0
2) Mean error and maximum error (mm)				
#	Landmark	N	Mean error	Maximum error
2	Tragion, right	45	2,3	5,3
4	Infraorbitale, right	45	2,1	4,4
5	Infraorbitale, left	45	0,9	2,4
9	Opisthocranion	45	1,3	3,2
10	Cervicale	45	1,8	4,0
13	Mesosternale	45	2,2	5,0
14	Thelion, right	45	1,8	4,9
15	Thelion, left	45	1,7	3,6
16	Iliocristale, right	45	2,1	5,2
17	Iliocristale, left	45	2,3	5,5
18	Anterior superior iliac spine, right	45	2,1	5,9
19	Anterior superior iliac spine, left	45	2,8	6,1
20	Stylian, right	45	2,1	3,5
22	Ulnar stylian, right	45	2,2	4,1
23	Ulnar stylian, left	45	1,3	2,4
24	Tibiale, right	45	2,8	5,5
25	Tibiale, left	45	2,5	4,4
28	Suprapatella, right	45	1,7	3,4
29	Suprapatella, left	45	2,1	4,4
30	Neck shoulder point, right	45	1,3	3,2
31	Neck shoulder point, left	45	1,2	2,4
32	Front neck point	45	1,9	4,1
33	Anterior axilla point, right	45	2,4	5,0
34	Anterior axilla point, left	45	2,3	4,4
35	Posterior axilla point, right	45	2,1	4,1
37	Omphalion	45	2,7	4,8
38	Trochanterion, right	45	2,5	4,5
39	Trochanterion, left	45	3,1	7,3
40	Buttock point, right	45	2,8	5,7
41	Buttock point, left	45	3,1	7,4
42	Radiale, right	45	2,2	3,9
43	Radiale, left	45	2,9	7,9

NOTE #1 Vertex (top of head) was excluded from analysis because it was automatically calculated rather than calculated from the marker position.

**Table B.2** (continued)

44	Mid patella, right	45	2,2	4,3
45	Mid patella, left	45	1,4	3,5
NOTE #1 Vertex (top of head) was excluded from analysis because it was automatically calculated rather than calculated from the marker position.				

## Annex C (informative)

### Example of report of evaluation of hidden area

#### C.1 General

[Table C.1](#) shows an example of report. [Figure C.1](#) shows examples of missing area.

**Table C.1 — Example of report**

Name of body scanner (Name of manufacturer)		Bodyline scanner C9036-02 (Hamamatsu photonics)	
Evaluated by		Digital Human Research Center, National Institute of Advanced Industrial Science and Technology (AIST)	
Date of test		26 May, 2009	
Place of test		Digital Human Research Center, AIST, 2-3-26 Aomi Koto-ku, Tokyo 135-0064, Japan	
Automatic fill hole		The system has automatically filling hole function, but it was not used	
1. Subject			
15 adult Japanese females 157,5 (147,0 to 164,8) cm, 52,2 (39,6 to 68,2) kg, 21,1 (17,6 to 31,6) kg/m <sup>2</sup>			
15 adult Japanese males 169,8 (160,9 to 177,3) cm, 62,3 (49,4 to 83,6) kg, 21,6 (19,1 to 29,6) kg/m <sup>2</sup>			
2. Procedure			
Data captured by each camera head was exported in the text format, and Geomagic Studio was used to visualize the surface data.			
3. Results (Yes indicates the existence of missing area)			
Code number	Area	N of subjects with missing area: total number (female, male)	Comments
10	Top of the head	30 (15, 15)	Small missing area
11	Under the nose	4 (3, 1)	
12	Back of the ear	9 (3, 6)	
13	Pupil	1 (1, 0)	
14	Under the chin	30 (15, 15)	Size varies according to the shape
20	Over the shoulder	20 (15, 5)	Small missing area
21	Armpit and the trunk	30 (15, 15)	Small missing area
22	Under the bust	10 (9, 1)	Size varies according to the shape
23	Under the buttocks	10 (5, 5)	Small missing area
24	Under the crotch and the medial side of the thighs	30 (15, 15)	Large missing area at the medial side of the thighs
25	Side of the body, arms, and legs	0 (0, 0)	
30	Trunk side of the arm	30 (15, 15)	Large missing area in the upper arms. Size varies according to the shape
40	The plantar part of the foot	30 (15, 15)	Plantar part is completely missing
Other	Above the clavicle	10 (6, 4)	Missing area exists when there is a hollow



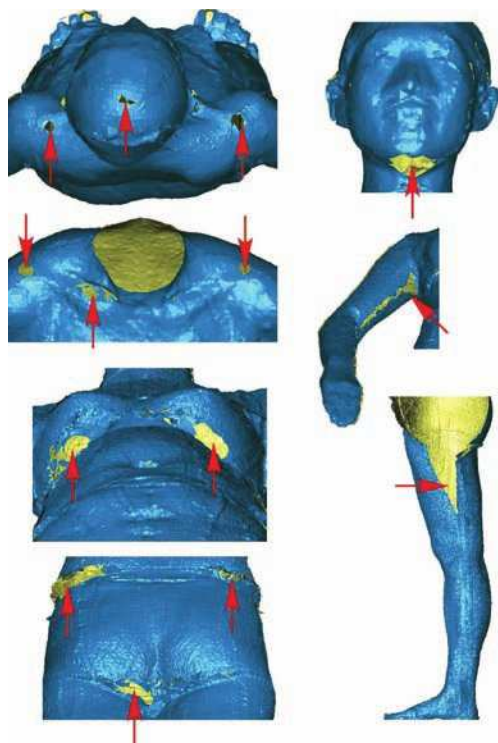

NOTE Arrows indicate missing areas.

Figure C.1 — Example of missing area



## Annex D (informative)

### Simultaneous superimposition of landmark coordinate data from 10 scans

#### D.1 General

Simultaneous superimposition means to superimpose plural sets of landmark coordinate data simultaneously by least-square method.

#### D.2 Procedure

Step 1: Coordinates of landmarks are obtained by available method for 10 scans of the same dummy. Since the test object is the same, size normalization is not required. Select one arbitrary scan as the base data.

Step 2: Superimpose each of the remaining nine scans on the base data by minimizing the sum of distances between corresponding data points.

Step 3: After superimposition, calculate sum of distances between corresponding landmarks for all possible data of the 10 sets of data. Calculate mean distance between corresponding landmarks.

Step 4: If the mean distance is larger than the predetermined threshold, mean landmark coordinates are calculated from the 10 sets of data after superimposition, use the mean as the base data, and repeat step 2 and step 3 until the mean distance is smaller than the predetermined threshold. In the example in [Annex B](#), the predetermined threshold was set to 1.0e-09.

#### D.3 Alternative procedure

When a simultaneous superimposition is impossible, superimpose two sets of landmark coordinate data for all possible pairs of different scans, and use all results for calculating mean error and the maximum error. When this procedure is used, it should be described in the report.

## Bibliography

- [1] KOUCHI M., MOCHIMARU M., BRADTMILLER B., DAANEN H., LI P., NACHER B. A protocol for evaluating the accuracy of 3D body scanners. *Work*. 2012, **41** pp. 4010–4017
- [2] KOUCHI M., MOCHIMARU M., BRADTMILLER B., DAANEN H., LI P., NACHER B. *A protocol for evaluating the accuracy of 3D body scanners*. Proceedings of the 1st Asian Workshop on 3D Body Scanning Technologies, Tokyo, 2012
- [3] VDI/VDE 2634-2, 2002, *Optical 3-D measuring systems – Part 2 Optical systems based on area scanning*



