**Wood-based panels — Determination of
wet bending strength after immersion in
water at 70 °C or 100 °C (boiling
temperature)**

*Panneaux à base de bois — Détermination de la résistance à la flexion
humide après immersion dans de l'eau à 70 °C ou à 100 °C
(température d'ébullition)*



PDF disclaimer

This PDF file may contain embedded typefaces. In accordance with Adobe's licensing policy, this file may be printed or viewed but shall not be edited unless the typefaces which are embedded are licensed to and installed on the computer performing the editing. In downloading this file, parties accept therein the responsibility of not infringing Adobe's licensing policy. The ISO Central Secretariat accepts no liability in this area.

Adobe is a trademark of Adobe Systems Incorporated.

Details of the software products used to create this PDF file can be found in the General Info relative to the file; the PDF-creation parameters were optimized for printing. Every care has been taken to ensure that the file is suitable for use by ISO member bodies. In the unlikely event that a problem relating to it is found, please inform the Central Secretariat at the address given below.

© ISO 2005

All rights reserved. Unless otherwise specified, no part of this publication may be reproduced or utilized in any form or by any means, electronic or mechanical, including photocopying and microfilm, without permission in writing from either ISO at the address below or ISO's member body in the country of the requester.

ISO copyright office
Case postale 56 • CH-1211 Geneva 20
Tel. + 41 22 749 01 11
Fax + 41 22 749 09 47
E-mail copyright@iso.org
Web www.iso.org

Published in Switzerland

Foreword

ISO (the International Organization for Standardization) is a worldwide federation of national standards bodies (ISO member bodies). The work of preparing International Standards is normally carried out through ISO technical committees. Each member body interested in a subject for which a technical committee has been established has the right to be represented on that committee. International organizations, governmental and non-governmental, in liaison with ISO, also take part in the work. ISO collaborates closely with the International Electrotechnical Commission (IEC) on all matters of electrotechnical standardization.

International Standards are drafted in accordance with the rules given in the ISO/IEC Directives, Part 2.

The main task of technical committees is to prepare International Standards. Draft International Standards adopted by the technical committees are circulated to the member bodies for voting. Publication as an International Standard requires approval by at least 75 % of the member bodies casting a vote.

Attention is drawn to the possibility that some of the elements of this document may be the subject of patent rights. ISO shall not be held responsible for identifying any or all such patent rights.

ISO 20585 was prepared by Technical Committee ISO/TC 89, *Wood-based panels*.

Wood-based panels — Determination of wet bending strength after immersion in water at 70 °C or 100 °C (boiling temperature)

1 Scope

This International Standard specifies methods for determining the bending strength of particleboards and fibreboards after immersion in hot water. Method A is applicable for water at 70 °C and Method B for water at 100 °C (boiling temperature).

NOTE The boiling temperature can slightly differ depending on the altitude above sea level.

2 Normative references

The following referenced documents are indispensable for the application of this document. For dated references, only the edition cited applies. For undated references, the latest edition of the referenced document (including any amendments) applies.

ISO 9424, *Wood-based panels — Determination of dimensions of test pieces*

ISO 16978, *Wood-based panels — Determination of modulus of elasticity in bending and of bending strength*

ISO 16999, *Wood-based panels — Sampling and cutting of test pieces*

3 Principle

Test pieces are immersed in hot or boiling water for 2 h, cooled for 1 h, and then tested for bending strength. The test is designed to provide information on the durability of the board after moisture penetration.

4 Apparatus

4.1 Hot-water tank, stainless steel with lid, heated so that the water inside is thermostatically controlled to the correct temperature.

The tank should be constructed in such a way that the heating zone is separated from the sample immersion by baffles or by use of separate chambers. This will prevent erosion of the test pieces by air bubbles and strong water flows (see Figure 1).

A level control device (e.g. float chamber) could be also required to maintain the water level, as water will be lost due to vaporization. Water shall cover the test pieces to a depth of (75 ± 15) mm. A backflow connection between the tank and the float chamber will also ensure preheating of water entering the tank from the float chamber.

For the 70 °C test (Method A), the temperature of the water shall be controlled to (70 ± 3) °C.

For the boiling test (Method B), the water shall be in state of gentle boiling, with no violent or turbulent action on or below the surface.

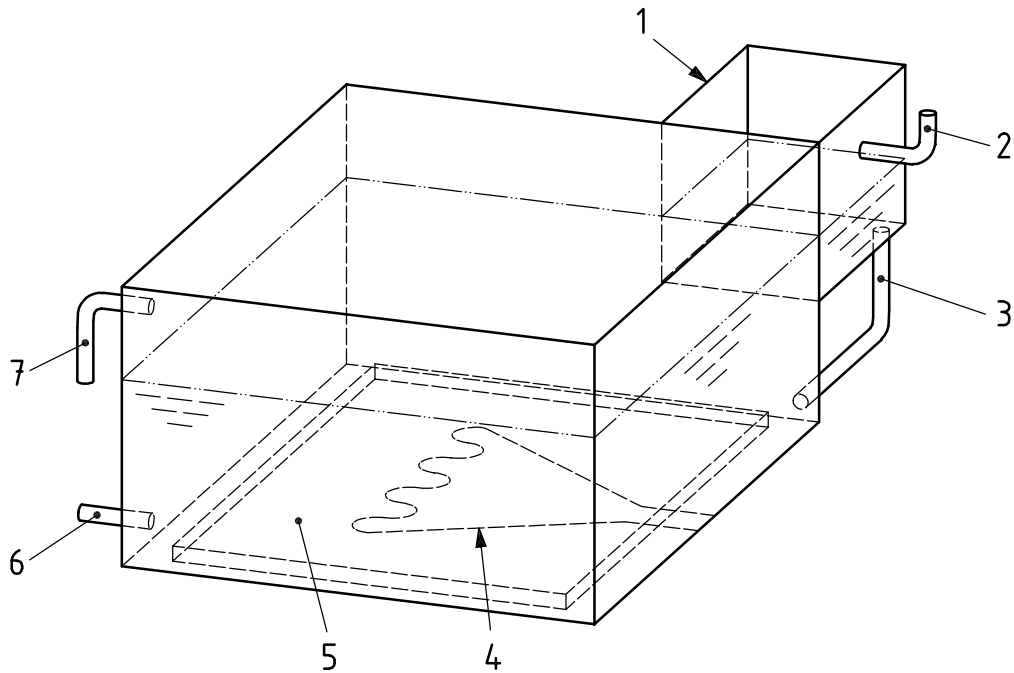

Key

- 1 float chamber
- 2 water in
- 3 make-up water pipe connection (allows backflow for prewarming)
- 4 heating element
- 5 baffle plate
- 6 drain
- 7 overflow drain

Figure 1 — Hot-water tank

4.2 Test-piece holding racks that hold the test pieces so that their length is horizontal and the short edge vertical (see Figure 2).

Test pieces shall have a minimum clearance of 15 mm from each other and 40 mm from the bottom of the tank and the heating element. The rack should have sufficient mass so that when it is loaded and immersed in water, it is stable and does not float or bounce up and down.

4.3 Room-temperature water bath with an internal volume capable of immersing the complete holding racks and test pieces and with an initial temperature of $(20 \pm 2) ^\circ\text{C}$. After removal of test pieces from the hot water tank and immersion in the room temperature water bath, the water bath shall be maintained at a temperature of $(20 \pm 2) ^\circ\text{C}$ during the immersion cycle.

4.4 Test machine: bending strength test apparatus, as specified in ISO 16978.

4.5 Measuring instruments, as specified in ISO 9424.

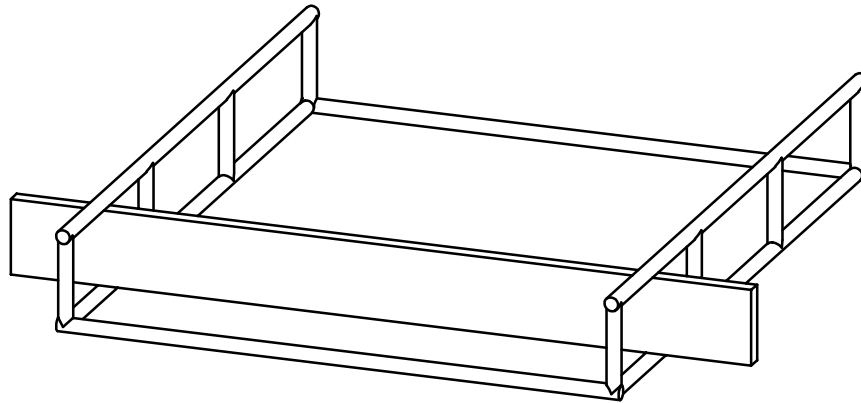

Figure 2 — Test piece holding rack

5 Test pieces

5.1 Sampling

Sampling and cutting of the test pieces shall be carried out according to ISO 16999.

5.2 Dimensions

The dimensions of the test pieces shall be as specified in ISO 16978.

5.3 Number of test pieces

Six test pieces shall be used, three with the machine direction parallel with, and three with the machine direction perpendicular to, the length of the test piece.

5.4 Conditioning

The test pieces shall be conditioned to constant mass in an atmosphere with a mean relative humidity of $(65 \pm 5) \%$ and a temperature of $(20 \pm 2) ^\circ\text{C}$. Constant mass is considered to be reached when the results of two successive weighing operations, carried out at an interval of 24 h, do not differ by more than 0,1 % of the mass of the test piece.

6 Procedure

6.1 Initial measurement

After conditioning, determine the thickness and width of the test piece in accordance with ISO 9424.

6.2 Immersion procedure — Method A ($70 ^\circ\text{C}$)

Use fresh, potable tap-water for each test. Ensure that the hot-water tank is at the correct temperature of $(70 \pm 3) ^\circ\text{C}$.

Insert the test pieces into the holding rack and then place the rack into the hot water tank so that the test pieces are covered by (75 ± 15) mm of water. Maintain the water temperature at the correct temperature for the duration of the test of 2 h. Any make-up water added shall be at the correct temperature.

6.3 Immersion procedure — Method B (100 °C, boiling water)

Use fresh, potable tap-water for each test. Ensure that the water is boiling gently at a temperature of at least 97 °C.

Insert the test pieces into the holding rack and then place the rack into the hot-water tank so that the test pieces are covered by (75 ± 15) mm of water. Maintain the water temperature at gentle boiling for the duration of the test of 2 h. Any make-up water added shall be at the correct temperature.

6.4 Cooling — Methods A and B

After (120 ± 5) min in the hot-water tank, remove the holding rack and test pieces. Then immerse in the room-temperature water bath for (60 ± 5) min. Remove from the water bath, wipe to remove excess water, and test the samples for bending strength within 15 min. If it is not possible to test within this time frame, test pieces may be stored in plastic bags for up to 4 h, then tested.

6.5 Bending strength test — Methods A and B

Determine the bending strength of the test pieces according to ISO 16978.

7 Expression of results

The wet bending strength, f_{mw} , of the board shall be calculated for each test piece by the following equation:

$$f_{mw} = \frac{3F_{max}l_1}{2bt^2}$$

where

f_{mw} is the wet bending strength in megapascals (MPa);

F_{max} is the maximum load, in newtons (N);

b is the width of test piece prior to immersion, in millimetres (mm);

t is the thickness of test piece prior to immersion, in millimetres (mm);

l_1 is the span between support centres, in millimetres (mm).

The wet bending strength of each test piece shall be expressed to three significant figures.

8 Test report

The test report shall be completed in accordance with ISO 16999.

In addition, the test report shall include the following information:

- each test report shall identify whether the results are determined according to Method A or Method B;
- all information about the test which is not in accordance with this International Standard (conditioning, water temperature, etc.).

