**Paints and varnishes — Determination
of stone-chip resistance of coatings —**

**Part 1:
Multi-impact testing**

*Peintures et vernis — Détermination de la résistance des revêtements
aux impacts de cailloux —*

Partie 1: Essais de chocs multiples



COPYRIGHT PROTECTED DOCUMENT

© ISO 2017, Published in Switzerland

All rights reserved. Unless otherwise specified, no part of this publication may be reproduced or utilized otherwise in any form or by any means, electronic or mechanical, including photocopying, or posting on the internet or an intranet, without prior written permission. Permission can be requested from either ISO at the address below or ISO's member body in the country of the requester.

ISO copyright office
Ch. de Blandonnet 8 • CP 401
CH-1214 Vernier, Geneva, Switzerland
Tel. +41 22 749 01 11
Fax +41 22 749 09 47
copyright@iso.org
www.iso.org

Contents

	Page
Foreword	iv
Introduction	v
1 Scope	1
2 Normative references	1
3 Terms and definitions	1
4 Principle	1
5 Apparatus	2
6 Materials	3
7 Test panels	4
7.1 Substrate	4
7.2 Preparation and coating	4
7.3 Thickness of coating	4
8 Procedure	4
8.1 Conditioning of the test panels	4
8.2 Test conditions	4
8.3 Projection of grit	4
9 Evaluation	5
10 Precision	5
10.1 Repeatability limit, <i>r</i>	5
10.2 Reproducibility limit, <i>R</i>	5
11 Test report	6
Annex A (informative) Examples of suitable procedures for removing loose paint	10
Annex B (informative) Recommended procedure for calibration of test apparatus (examination of the damaged area)	11

Foreword

ISO (the International Organization for Standardization) is a worldwide federation of national standards bodies (ISO member bodies). The work of preparing International Standards is normally carried out through ISO technical committees. Each member body interested in a subject for which a technical committee has been established has the right to be represented on that committee. International organizations, governmental and non-governmental, in liaison with ISO, also take part in the work. ISO collaborates closely with the International Electrotechnical Commission (IEC) on all matters of electrotechnical standardization.

The procedures used to develop this document and those intended for its further maintenance are described in the ISO/IEC Directives, Part 1. In particular the different approval criteria needed for the different types of ISO documents should be noted. This document was drafted in accordance with the editorial rules of the ISO/IEC Directives, Part 2 (see www.iso.org/directives).

Attention is drawn to the possibility that some of the elements of this document may be the subject of patent rights. ISO shall not be held responsible for identifying any or all such patent rights. Details of any patent rights identified during the development of the document will be in the Introduction and/or on the ISO list of patent declarations received (see www.iso.org/patents).

Any trade name used in this document is information given for the convenience of users and does not constitute an endorsement.

For an explanation on the meaning of ISO specific terms and expressions related to conformity assessment, as well as information about ISO's adherence to the World Trade Organization (WTO) principles in the Technical Barriers to Trade (TBT) see the following URL: www.iso.org/iso/foreword.html.

The committee responsible for this document is ISO/TC 35, *Paints and varnishes*, Subcommittee SC 9, *General test methods for paints and varnishes*.

This second edition cancels and replaces the first edition (ISO 20567-1:2005), which has been technically revised with the following main changes:

- a table with the particle size distribution of the grit material has been added;
- a note concerning the use of actual pressure gages has been added to [Figure 2](#);
- the clause on sampling has been deleted;
- the description of suitable methods for removal of loose paint have been transferred to an informative annex as examples and, for the method using adhesive tape, the adhesive strength of the tape is no longer specified;
- this document is revised editorially and the normative references have been updated.

A list of all parts in the ISO 20567 series can be found on the ISO website.

Introduction

In the automobile industry, multi-layer paint coatings are applied to car bodies for protection. Grit, road-metal and other materials can damage these coatings in such a way that individual layers come off or the whole coating delaminates from the substrate.

Stone chipping can be simulated by means of single- and/or multi-impact tests. ISO 20567-1 describes multi-impact testing; ISO 20567-2 and ISO 20567-3 describe single-impact tests.

NOTE A recommended procedure for calibration of the apparatus is given in [Annex B](#). Note that this annex is informative because the method described in it is not the only one suitable for checking whether a uniform impact pattern is produced.

Paints and varnishes — Determination of stone-chip resistance of coatings —

Part 1: Multi-impact testing

1 Scope

This document specifies three methods for the evaluation of the resistance of automobile finishes and other coatings to chilled-iron grit projected onto the surface under test to simulate the impact of small stones.

2 Normative references

The following documents are referred to in the text in such a way that some or all of their content constitutes requirements of this document. For dated references, only the edition cited applies. For undated references, the latest edition of the referenced document (including any amendments) applies.

ISO 565, *Test sieves — Metal wire cloth, perforated metal plate and electroformed sheet — Nominal sizes of openings*

ISO 1514, *Paints and varnishes — Standard panels for testing*

ISO 2808, *Paints and varnishes — Determination of film thickness*

ISO 3270, *Paints and varnishes and their raw materials — Temperatures and humidities for conditioning and testing*

ISO 11124-2, *Preparation of steel substrates before application of paints and related products — Specifications for metallic blast-cleaning abrasives — Part 2: Chilled-iron grit*

ISO 11125-2, *Preparation of steel substrates before application of paints and related products — Test methods for metallic blast-cleaning abrasives — Part 2: Determination of particle size distribution*

ISO 21227-2:2006, *Paints and varnishes — Evaluation of defects on coated surfaces using optical imaging — Part 2: Evaluation procedure for multi-impact stone-chipping test*

3 Terms and definitions

No terms and definitions are listed in this document.

ISO and IEC maintain terminological databases for use in standardization at the following addresses:

— IEC Electropedia: available at <http://www.electropedia.org/>

— ISO Online browsing platform: available at <http://www.iso.org/obp>

4 Principle

The stone-chip resistance of the coating under test is checked by projecting a large number of small sharp-edged bodies onto it in a short period of time. The material used in the test is chilled-iron grit, which is projected onto the coating at a defined angle using compressed air. The extent of the damage

caused will depend not only on the angle, but also on the pressure level, the mass of the projectiles, the duration of the bombardment and the design of the test apparatus.

Loose fragments of coating material are removed.

The extent of the damage is determined by comparison with pictorial reference standards.

5 Apparatus

Ordinary laboratory apparatus, together with the following.

5.1 Multi-impact tester.

[Figure 1](#) and [Figure 2](#) show the test apparatus and its dimensions.

The vibrating conveyor carries the grit from the funnel into the air blast in front of the grit-accelerating nozzle. It shall be designed so that the grit feed speed can be varied. The apparatus shall be capable of projecting 500 g of grit during a period of 10 s. The pressure chamber shall be large enough to allow the specified working pressure of 200 kPa to be held at a constant level for at least 10 s while the solenoid valve is open.

Used grit can be taken from the grit-catching chamber after the test and used again to a limited extent (see [6.1](#)).

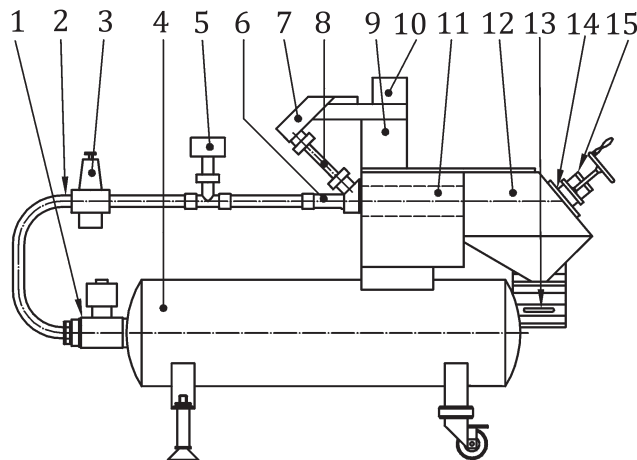

Key

1	solenoid valve	9	vibrating conveyor
2	compressed-air line	10	grit feed funnel
3	pressure reducer (to working pressure)	11	grit-accelerating pipe (accessible from back for replacement)
4	pressure chamber (capacity 90 l)	12	protective housing
5	manometer (indicates working pressure)	13	grit-catching chamber
6	air-accelerating nozzle	14	test panel
7	grit feed chute	15	test panel holder
8	grit feed pipe		

Figure 1 — Multi-impact tester — General view

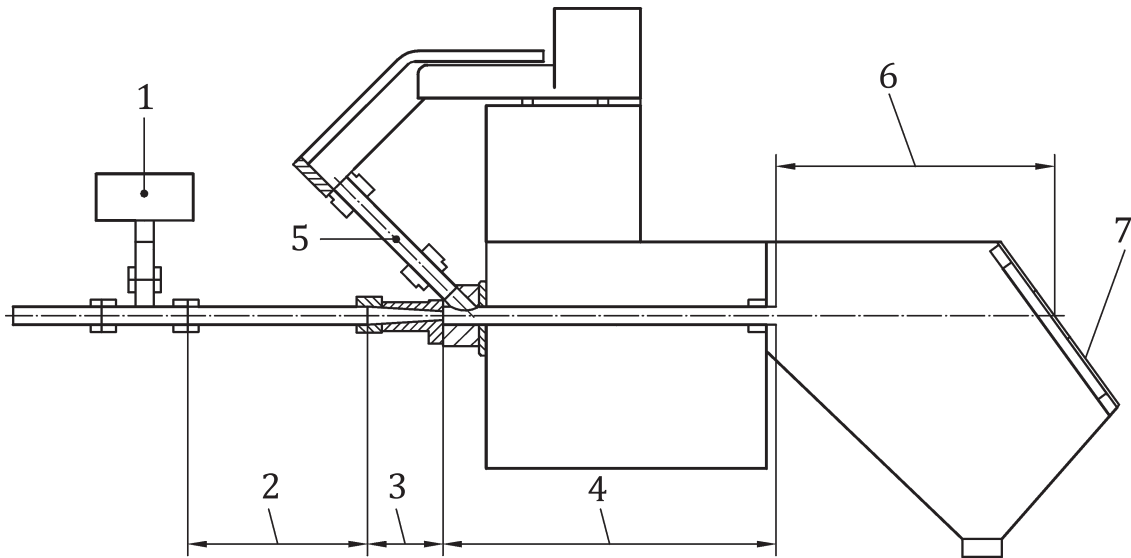
**Key**

- | | |
|------------------------------------------------------------------------------------------------------------------------------------------------------------------------------------------------------------------------------------------------------------------------------------------------------------------------------------------------------------------------------------------------------------------------------------------------------------------------------------------------------------------------------------------------------------------------------------------------------------------------------------------------------------------------------------------------------------------------------------------------------------------------------------------------------------------------------------|----------------------------------------------------------------------------------------------------------------------------------------------------------------------------------------------------------------------------------------------------------------------------------------------------------------------------------------------------------------------------------------------------------------------------------------------------------------------------------------------------------------------------------------------------------------------------------------------------------------------------------------------------------------------------------------------------------------------------------------------------|
| <p>1 pressure gauge</p> <ul style="list-style-type: none"> — measurement range: up to 400 kPa (= 4 bar) — diameter of scale: 100 mm — accuracy: class 1,0 <p>2 connecting pipe</p> <ul style="list-style-type: none"> — length: (190 ± 1) mm — inside diameter: $(19 \pm 0,2)$ mm <p>3 air-accelerating nozzle</p> <ul style="list-style-type: none"> — length: (80 ± 1) mm — inside diameter at entry: $(19 \pm 0,2)$ mm — inside diameter at exit: $(7 \pm 0,2)$ mm <p>4 flange and grit-accelerating pipe</p> <ul style="list-style-type: none"> — overall length: (352 ± 2) mm — inside diameter: $(30 \pm 0,2)$ mm | <p>5 grit feed pipe</p> <ul style="list-style-type: none"> — length: (205 ± 3) mm — inside diameter: (19 ± 1) mm — connected to grit-accelerating pipe at angle of $(45 \pm 1)^\circ$ and distance of (35 ± 1) mm from tip of air-accelerating nozzle <p>6 jet of grit</p> <ul style="list-style-type: none"> — distance from grit-accelerating pipe to centre of test panel: (290 ± 1) mm — angle between axis of jet and test panel: $(54 \pm 1)^\circ$ <p>7 aperture</p> <ul style="list-style-type: none"> — 80 mm \times 80 mm window defining test area on test panel |
|------------------------------------------------------------------------------------------------------------------------------------------------------------------------------------------------------------------------------------------------------------------------------------------------------------------------------------------------------------------------------------------------------------------------------------------------------------------------------------------------------------------------------------------------------------------------------------------------------------------------------------------------------------------------------------------------------------------------------------------------------------------------------------------------------------------------------------|----------------------------------------------------------------------------------------------------------------------------------------------------------------------------------------------------------------------------------------------------------------------------------------------------------------------------------------------------------------------------------------------------------------------------------------------------------------------------------------------------------------------------------------------------------------------------------------------------------------------------------------------------------------------------------------------------------------------------------------------------|

NOTE Instead of the mechanical pressure gauge described under point 1 in [Figure 2](#), an electronic pressure sensor with comparable data [e.g. measuring range up to 600 kPa (= 6 bar)/accuracy class 0,5] is often used nowadays and the working pressure is indicated in a display.

Figure 2 — Multi-impact tester — Detailed drawing and dimensions

6 Materials

6.1 Grit.

The grit¹⁾ shall be chilled-iron grit conforming to the requirements of ISO 11124-2, except that the particle size, determined in accordance with ISO 11125-2 and ISO 565, shall be as specified in [Table 1](#).

1) For information about grit suppliers, please contact the DIN Normenausschuss Beschichtungsstoffe und Beschichtungen (NAB), Burggrafenstraße 6, 10787 Berlin, Germany.

Table 1 — Particle size distribution

	Mesh size mm	Fraction %
On the sieve	5,00	— ^a
	4,50	20 to 25
	4,00	35 to 45
	3,55	30 to 40
Through the sieve	3,55	— ^a
^a To be discarded.		

100 g of the collected fractions in [Table 1](#) shall contain 300 ± 25 grit particles.

The grit shall be replaced after a maximum of 100 test runs. Do not replace the grit during an ongoing series of tests.

7 Test panels

7.1 Substrate

Use test panels of at least 100 mm × 100 mm in size.

7.2 Preparation and coating

Prepare each test panel in accordance with ISO 1514 before coating and drying or stoving. Use the application method specified by the paint manufacturer.

7.3 Thickness of coating

Determine the thickness, in micrometres, of the dry coating by one of the procedures specified in ISO 2808.

8 Procedure

8.1 Conditioning of the test panels

Condition the test panels for at least 16 h at (23 ± 2) °C and (50 ± 5) % relative humidity before carrying out the test (in accordance with ISO 3270).

8.2 Test conditions

Carry out the test at room temperature, i.e. 18 °C to 28 °C. State the temperature in the test report.

After conditioning, ensure that condensation does not form prior to or during the test.

8.3 Projection of grit

Load the tester with 500^{+20}_0 g of grit. Carry out the test using one of the sets of conditions given in [Table 2](#). The method used shall be agreed between the interested parties.

Weigh the grit after each test run (i.e. after each projection) and, if required, add grit to keep the total mass at 500^{+20}_0 g.

Check the length of time taken to project the grit with a stopwatch each time a new series of tests is started and, if required, during an ongoing series of tests.

After a maximum of 100 test runs (see 6.1), replace the used grit with 500 g of fresh grit. Do not replace the grit during an ongoing series of tests.

Remove any loose paint from the test area. Examples of suitable methods are given in Annex A. The method for removing the loose paint shall be agreed between the interested parties and shall be stated in the test report.

Table 2 — Test methods

Method	Pressure kPa ^a	Mass of grit g	Time taken to project grit s
A	100 ± 10	2 × 500 ⁺²⁰ ₀	2 × (10 ± 2)
B	200 ± 10	2 × 500 ⁺²⁰ ₀	2 × (10 ± 2)
C	200 ± 10	1 × 500 ⁺²⁰ ₀	10 ± 2
	followed by, for example, corrosion or weathering exposure, then immediately carry out the projection in accordance with 8.3 using the following parameters.		
	200 ± 10	1 × 500 ⁺²⁰ ₀	10 ± 2

^a 100 kPa = 1 bar.

9 Evaluation

Evaluate the damage (break down or flaking) on the exposed test area by comparison with the reference standards shown in Figure 3.

NOTE The figures are showing the mean damage of rating. The upper and lower limit of damaged area shown in the figures are determined in ISO 21227-2:2006, Table A.1.

The comparison can be done visually or by means of optical imaging in accordance with ISO 21227-2. The reference standards represent ratings from 0,5 to 5,0 in steps of 0,5. Estimate and record intermediate ratings as necessary.

In addition to the degree of chipping, specify, if possible, the main separation level or the layers of the paint system between which loss of adhesion occurred.

Markings are not evaluated.

10 Precision

10.1 Repeatability limit, *r*

The repeatability limit, *r*, is the value below which the absolute difference between two test results can be expected to lie, with a 95 % probability, when this method is used under repeatability conditions, i.e. when the test results are obtained on identical material by one operator in one laboratory within a short interval of time using the same apparatus.

For this method, *r* is 0,5 on the rating scale.

10.2 Reproducibility limit, *R*

The reproducibility limit, *R*, is the value below which the absolute difference between two test results, each the mean of duplicates, can be expected to lie, with a 95 % probability, when this test method is

used under reproducibility conditions, i.e. when the test results are obtained on identical material by operators in different laboratories using different apparatus.

For this method, *R* is 1,0 on the rating scale.

11 Test report

The test report shall contain at least the following information:

- a) all details necessary for complete identification of the product tested (manufacturer, trade name, batch number, etc.);
- b) a reference to this document, i.e. ISO 20567-1;
- c) the details of the test panels, including
 - 1) the details of the substrate (including material and thickness) and its surface preparation,
 - 2) the method used to apply the product to the substrate, including the drying time and drying conditions for each layer,
 - 3) if applicable, the conditions under which the panels were aged,
 - 4) the details of how the test panels were conditioned before the test and, if applicable, details of any tests carried out previously with the same test panels, and
 - 5) the dry-film thickness of the coating, in micrometres, and the method in ISO 2808 used to measure it, plus a note as to whether the tested coating consisted of a single layer or several layers;
- d) the test method used (A, B or C), as well as for method C, only the details of the corrosion or weathering exposure conditions;
- e) the ambient temperature during the test;
- f) the details of the chilled-iron grit, including the manufacturer, trade name and mean particle size;
- g) the details of the method used to remove loose paint (see [Annex A](#));
- h) the results of the test, as described in [Clause 9](#);
- i) any deviations from the procedure specified;
- j) any unusual features (anomalies) observed during the test;
- k) the date of testing;
- l) the name of the person who carried out the test.

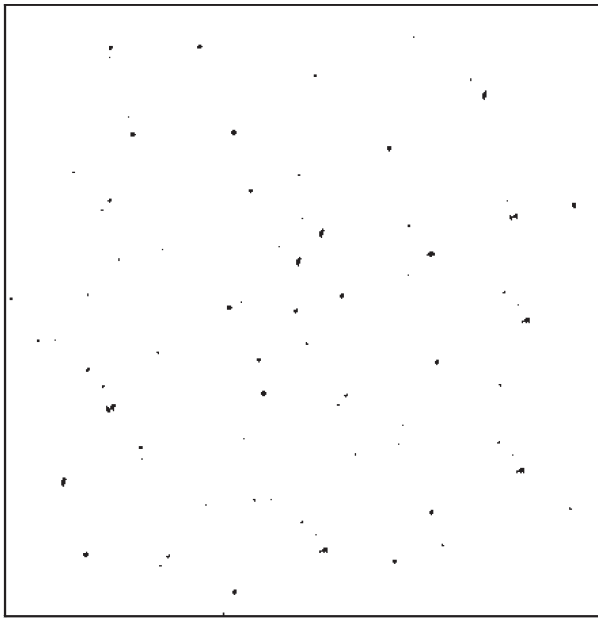

a) Rating 0,5 Affected area 0,2 %

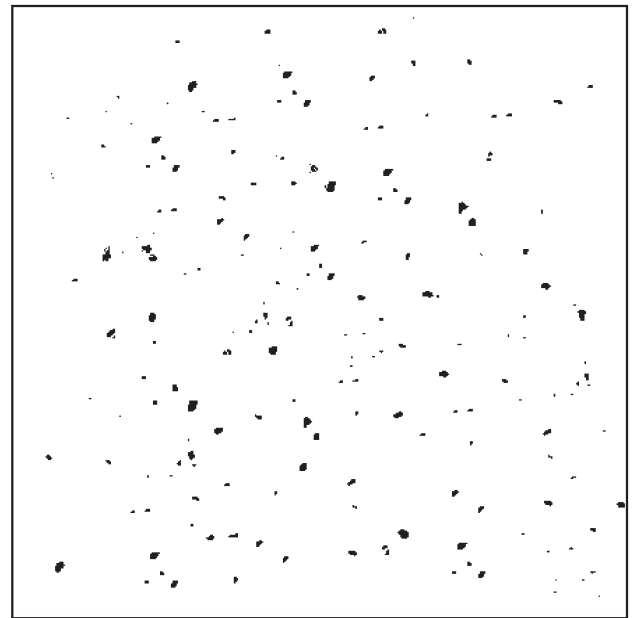

b) Rating 1,0 Affected area 1,0 %

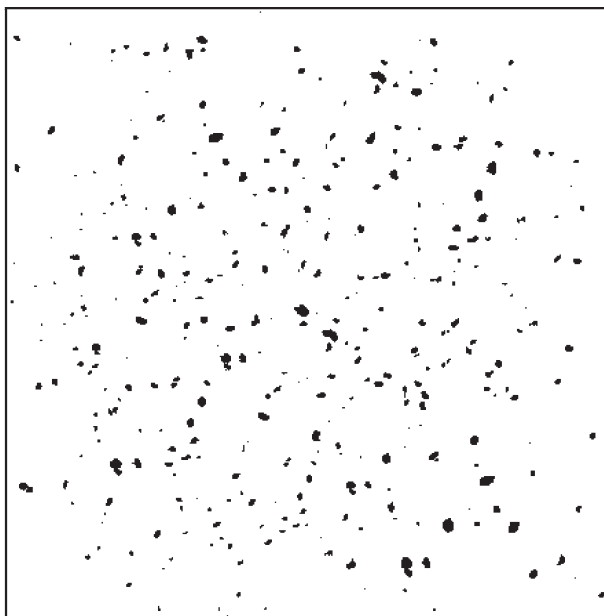

c) Rating 1,5 Affected area 2,5 %

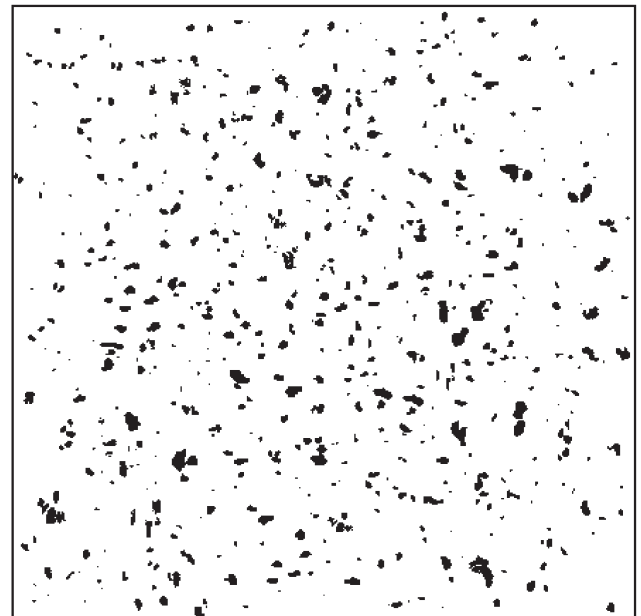

d) Rating 2,0 Affected area 5,5 %

Figure 3 (continued)

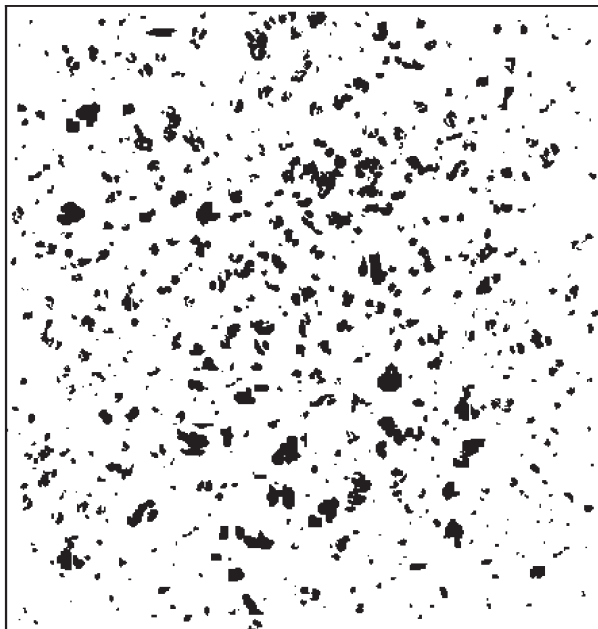

e) Rating 2,5 Affected area 10,7 %



f) Rating 3,0 Affected area 19,2 %

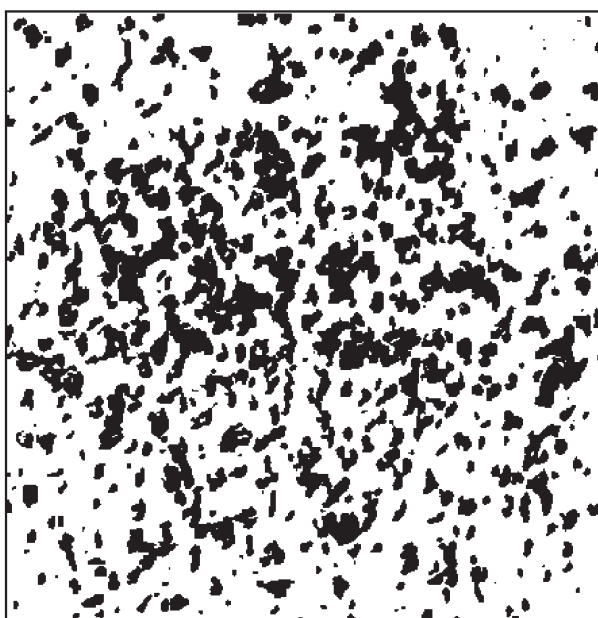

g) Rating 3,5 Affected area 29,0 %

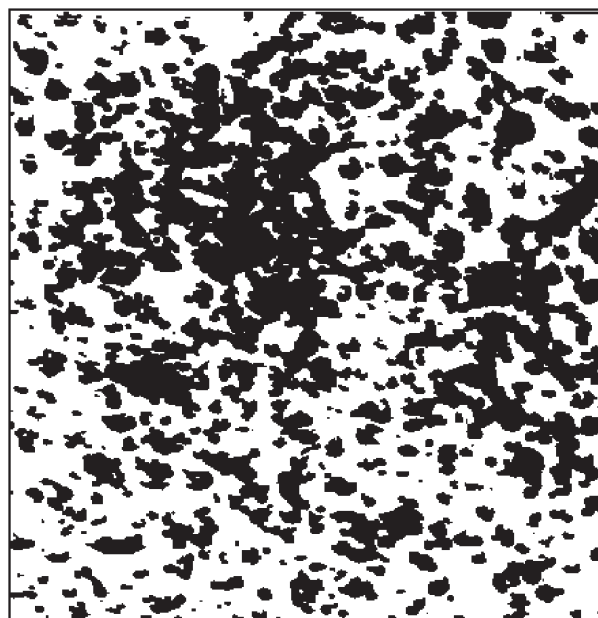

h) Rating 4,0 Affected area 43,8 %

Figure 3 (continued)

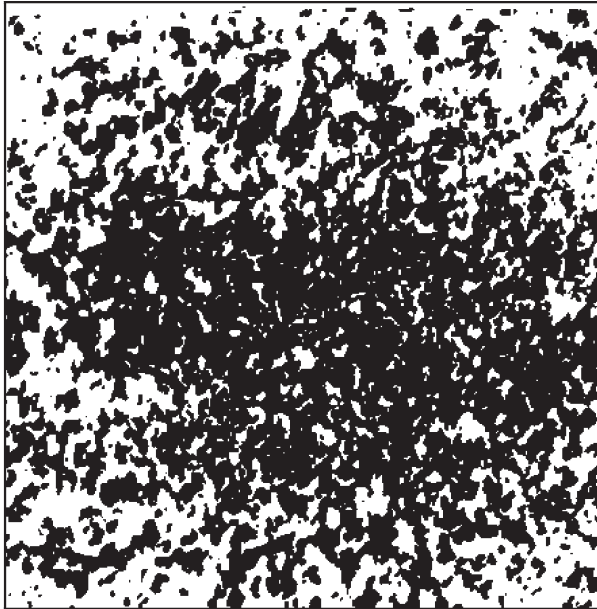

i) Rating 4,5 Affected area 58,3 %

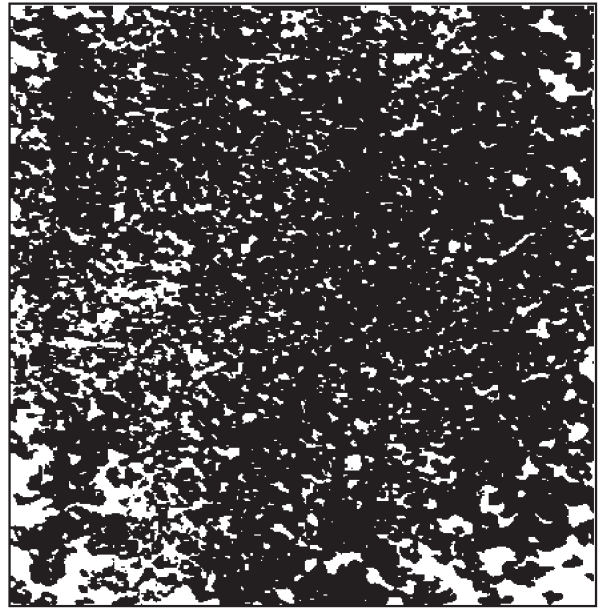

j) Rating 5,0 Affected area 81,3 %

Figure 3 — Pictorial standards for stone chip resistance rating

Annex A **(informative)**

Examples of suitable procedures for removing loose paint

A.1 Brushing

Brush the panel lightly with a soft brush several times backwards and several times forwards.

A.2 Using pressure-sensitive adhesive tape

Place a strip of adhesive tape approximately 120 mm to 150 mm long over the test area of the test panel and press it firmly onto the surface using a fingertip, fingernail or suitable device. Bend one end of the tape upwards and pull the strip off with a jerk (at an angle of 60° to the test panel) to remove chips of paint that have not been completely separated from the panel.

To ensure good contact with the coating, rub the tape firmly with a fingertip or fingernail.

NOTE The operation of applying and removing the tape can be carried out more than once, depending on the kind of coating.

A.3 Using compressed air or nitrogen

Remove any loose paint with compressed air or nitrogen.

Annex B (informative)

Recommended procedure for calibration of test apparatus (examination of the damaged area)

B.1 Materials

B.1.1 Grit, as specified in [6.1](#).

B.2 Apparatus

B.2.1 Calibrated scales, capable of weighing 500 g to an accuracy of 0,1 g.

B.2.2 Calibrated stopwatch.

B.2.3 Carbon paper.

B.2.4 White paper, for example, photocopying paper.

B.2.5 Plastics film, for example, PE film with a thickness of approximately 150 µm to 200 µm, or transparent envelope.

B.2.6 Steel panel, as specified in [8.1](#), or aluminium panel, with a minimum thickness of 1,25 mm.

B.3 Procedure

To calibrate the test apparatus, mount a calibration panel constructed as shown in [Figure B.1](#) in the apparatus. Then project (500 ± 5) g of fresh grit onto the test area within (10 ± 2) s, using an air pressure of 200 kPa (= 2 bar).

Visually evaluate the marks produced on the sheet of white paper by the impact of the grit on the carbon paper. The ratio of black areas to white areas shall be the same each time the test apparatus is calibrated. Use the calibration impact pattern sheet supplied with the apparatus as a reference standard.

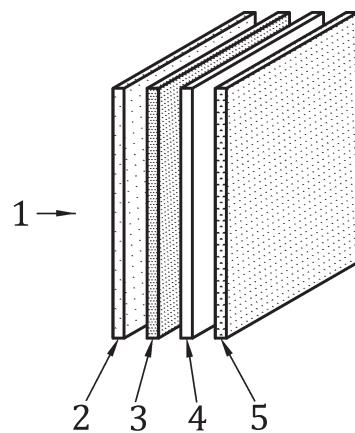

Key

- 1 test area
- 2 plastics film (or transparent envelope)
- 3 carbon paper
- 4 white paper
- 5 steel or aluminium panel

Figure B.1 — Calibration panel

