

---

---

**Paints and varnishes —  
Determination of the scratch  
resistance of a coating system using a  
laboratory-scale car-wash**

*Peintures et vernis — Détermination de la résistance à la rayure d'un système de peinture sur un poste de lavage automobile de laboratoire*



Reference number  
ISO 20566:2013(E)

© ISO 2013



**COPYRIGHT PROTECTED DOCUMENT**

© ISO 2013

All rights reserved. Unless otherwise specified, no part of this publication may be reproduced or utilized otherwise in any form or by any means, electronic or mechanical, including photocopying, or posting on the internet or an intranet, without prior written permission. Permission can be requested from either ISO at the address below or ISO's member body in the country of the requester.

ISO copyright office  
Case postale 56 • CH-1211 Geneva 20  
Tel. + 41 22 749 01 11  
Fax + 41 22 749 09 47  
E-mail [copyright@iso.org](mailto:copyright@iso.org)  
Web [www.iso.org](http://www.iso.org)

Published in Switzerland

-----

# Contents

	Page
Foreword .....	iv
Introduction .....	v
<b>1 Scope</b> .....	<b>1</b>
<b>2 Normative references</b> .....	<b>1</b>
<b>3 Terms and definitions</b> .....	<b>1</b>
<b>4 Apparatus</b> .....	<b>2</b>
<b>5 Washing suspension</b> .....	<b>3</b>
<b>6 Sampling</b> .....	<b>4</b>
<b>7 Test panels</b> .....	<b>4</b>
<b>8 Procedure</b> .....	<b>4</b>
<b>9 Evaluation</b> .....	<b>5</b>
<b>10 Precision</b> .....	<b>5</b>
10.1 Repeatability limit <i>r</i> .....	5
10.2 Reproducibility limit <i>R</i> .....	5
<b>11 Test report</b> .....	<b>5</b>
<b>Annex A (normative) Verification and calibration of the washing equipment</b> .....	<b>7</b>

## Foreword

ISO (the International Organization for Standardization) is a worldwide federation of national standards bodies (ISO member bodies). The work of preparing International Standards is normally carried out through ISO technical committees. Each member body interested in a subject for which a technical committee has been established has the right to be represented on that committee. International organizations, governmental and non-governmental, in liaison with ISO, also take part in the work. ISO collaborates closely with the International Electrotechnical Commission (IEC) on all matters of electrotechnical standardization.

International Standards are drafted in accordance with the rules given in the ISO/IEC Directives, Part 2.

The main task of technical committees is to prepare International Standards. Draft International Standards adopted by the technical committees are circulated to the member bodies for voting. Publication as an International Standard requires approval by at least 75 % of the member bodies casting a vote.

Attention is drawn to the possibility that some of the elements of this document may be the subject of patent rights. ISO shall not be held responsible for identifying any or all such patent rights.

ISO 20566 was prepared by Technical Committee ISO/TC 35, *Paints and varnishes*, Subcommittee SC 9, *General test methods for paints and varnishes*.

This second edition cancels and replaces the first edition (ISO 20566:2005), which has been technically revised. The main changes are:

- a) a “terms and definitions” clause has been added, defining the terms mar, scratch, double pass, test area and reflow effect;
- b) tolerances have been added to all key numerical values, such as dimensions;
- c) the spread of the spray jet has been changed from 60° to 65°;
- d) the thickness of the test panels has been specified;
- e) the test procedure has been described in more detail;
- f) a visual examination of the test panels has been added.

## Introduction

With this test procedure, it is important to note that the test results will not, over time, remain constant, as a result of changes to the brush material. As the brush ages, the test will become more severe. As a result, the test procedure is suitable only for comparative tests carried out at any one time and using relatively short runs. Readings obtained using equipment which has accumulated different total numbers of operating hours are not comparable with each other.

www.iso.org



# Paints and varnishes — Determination of the scratch resistance of a coating system using a laboratory-scale car-wash

## 1 Scope

This International Standard describes a test procedure for assessing the scratch resistance of organic paint coatings<sup>1)</sup>, in particular paint coatings used in the automotive industry (i.e. for assessing their car-wash resistance). Machine-based washing is simulated in the laboratory environment using a rotating brush and synthetic dirt. The test conditions have been designed to be as close as possible to the real conditions in a car-wash. If the test parameters are suitably chosen, the method can also be used for testing protective plastics films and plastics components.

## 2 Normative references

The following referenced documents are indispensable for the application of this document. For dated references, only the edition cited applies. For undated references, the latest edition of the referenced document (including any amendments) applies.

ISO 1513, *Paints and varnishes — Examination and preparation of samples for testing*

ISO 2813, *Paints and varnishes — Determination of specular gloss of non-metallic paint films at 20°, 60° and 85°*

ISO 4618, *Paints and varnishes — Terms and definitions*

ISO 4628-1, *Paints and varnishes — Evaluation of degradation of coatings — Designation of quantity and size of defects, and of intensity of uniform changes in appearance — Part 1: General introduction and designation system*

ISO 7724-1, *Paints and varnishes — Colorimetry — Part 1: Principles*

ISO 7724-2, *Paints and varnishes — Colorimetry — Part 2: Colour measurement*

ISO 7724-3, *Paints and varnishes — Colorimetry — Part 3: Calculation of colour differences*

ISO 13076, *Paints and varnishes — Lighting and procedure for visual assessments of coatings*

ISO 13803, *Paints and varnishes — Determination of reflection haze on paint films at 20°*

ISO 15528, *Paints, varnishes and raw materials for paints and varnishes — Sampling*

## 3 Terms and definitions

For the purposes of this document, the terms and definitions given in ISO 4618 and the following apply.

### 3.1

#### **mar, n**

blemish on the surface of a coating, extending over a particular area of the coating and visible due to the difference in the light-reflection properties of the area affected compared with the light-reflection properties of adjacent areas

1) For the term “coating”, see ISO 4618.

3.2

**scratch, n**

cut or gouge through the surface of a coating, made by contact with a sharp object

3.3

**double pass**

one back-and-forward movement of the test panel holder

3.4

**test area**

area which is evaluated

3.5

**reflow effect**

ability of the coating surface to revert to its original appearance after damage such as scratching

## 4 Apparatus

The apparatus<sup>2)</sup> shall comprise at least the following individual components:

### 4.1 Washing brush:

Diameter	(1 000 ± 40) mm
Width	min. 300 mm
Material	polyethylene
Profile	x-shaped, spliced
Bristle thickness	(0,8 ± 0,2) mm
Bristle length	(440 ± 20) mm visible
Penetration depth	(100 ± 20) mm (see Figure 1)
Speed of brush rotation	(127 ± 5) min <sup>-1</sup> , in the direction opposite to the direction of travel of the test panel holder

The replacement of washing brushes is decided by testing a control panel. The control panel material shall be chosen to reflect changes in the washing brush, so that it is possible to differentiate between a new and a used brush. In practice, the maximum lifetime of the washing brush is often specified as between 30 h and 50 h.

It is recommended that a control panel coated with a black non-metallic paint and a clear coating on top be used. Gloss shall be > 80 gloss units, measured at 20°. The washing brush shall be replaced by a new brush if the gloss of the control panel changes by more than 6 gloss units compared with a new brush.

### 4.2 Spray nozzles, made of stainless steel:

Spread of jet	65°
Rate of flow of washing suspension	(2,2 ± 0,2) l/min at (300 ± 50) kPa

The two nozzles shall spray alternately, against the direction of travel of the test panel holder. They shall produce the specified spray pattern (see Annex A).

---

2) Information on procuring the equipment is available from: DIN Deutsches Institut für Normung e.V., NAB, Burggrafenstrasse 6, 10787 Berlin, Germany.



#### 4.3 Test panel holder:

Feed speed	$(5,0 \pm 0,2)$ m/min
Pattern of movement	If the brush is rotating clockwise, the right nozzle is spraying and the test panel holder travels from left to right (and <i>vice versa</i> ) — see Figure 1.

Dimensions in millimetres

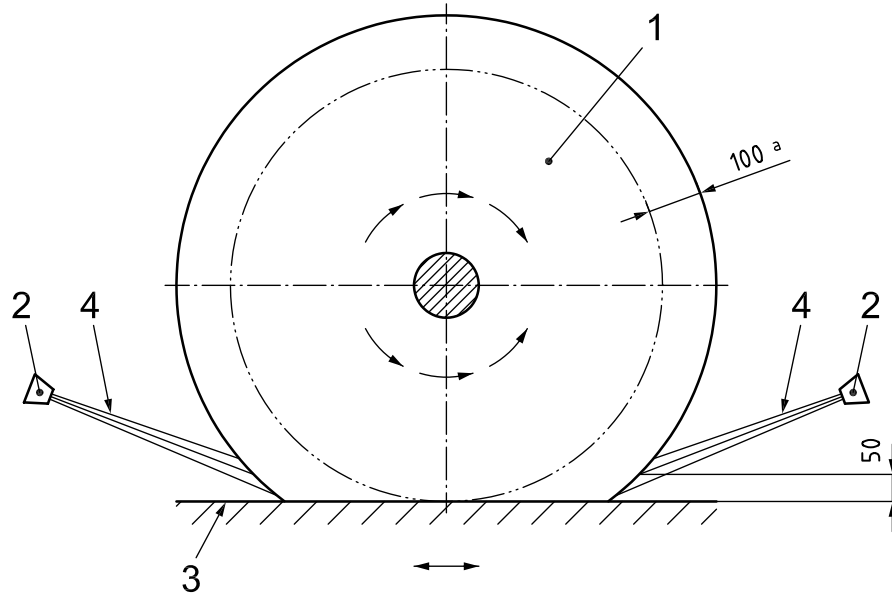

#### Key

- 1 washing brush
- 2 spray nozzle
- 3 test panel holder
- 4 spray jet (centreline of jet strikes brush directly, 50 mm above test panel holder)
- a Penetration depth.

**Figure 1 — Pattern of movement of washing brush and spray nozzles with respect to test panel holder**

**4.4 Container**, suitable for holding the washing suspension during the test.

## 5 Washing suspension

Prepare a suspension consisting of  $(1,50 \pm 0,05)$  g of silica powder (silica micro-powder having a mean particle size of  $24 \mu\text{m}$ )<sup>3)</sup> per litre of tap water in a suitable container, mixing it by stirring vigorously. The water temperature shall be between  $15 \text{ }^\circ\text{C}$  and  $30 \text{ }^\circ\text{C}$ .

The suspension shall be stirred continuously during the test in such a way that the silica powder does not settle on the bottom of the container as this would result in variations in the concentration.

The suspension may be reused once the test equipment has come to a standstill. However, it is essential that the suspension be stirred thoroughly again before being reused.

3) Information on procuring the silica powder is available from: DIN Deutsches Institut für Normung e.V., NAB, Burggrafenstrasse 6, 10787 Berlin, Germany.

## 6 Sampling

Take a representative sample of the product to be tested, as described in ISO 15528.

Examine and prepare each sample for testing, as described in ISO 1513.

If testing a clearcoat, the basecoat shall be single shade of black.

## 7 Test panels

Test panels shall be flat and free of deformations. The substrate and size shall be as agreed between the interested parties. The thickness of the test panels should preferably be between 0,5 mm and 5 mm. With other thicknesses, the depth of penetration into the washing brush and the angle of approach of the brush shall be adjusted by setting the test-panel holder to the correct height.

The spraying, drying/hardening and stoving parameters, and the ageing and conditioning before the test, shall be as agreed between the interested parties.

## 8 Procedure

Carry out the test at room temperature (20 °C to 30 °C).

The optimum test area shall be identified for each test apparatus, especially after changing the brush, by a control test, as follows. Using a control panel (see Clause A.1), determine the area on the test panels in which the difference in gloss compared to the most scratched area is not more than 15 gloss units. Do not evaluate the area at least 5 cm wide at each end of the test panels or the areas at least 3 cm wide along the edges of the panels, parallel to the direction of travel of the test panels.

Before carrying out a test, perform a preliminary run without any test panels, carrying out 10 washing operations (10 double passes), to distribute the washing suspension evenly in the apparatus.

Make sure that the thickness of the test panels is the same over the whole test area.

Prior to testing, examine the coated test panels visually in accordance with ISO 13076 and determine the initial value of the parameter to be measured, e.g. gloss in accordance with ISO 2813, haze in accordance with ISO 13803 or colour in accordance with ISO 7724.

Set the required pressure and verify it.

Position the test panels on the test panel holder and carry out 10 washing operations (10 double passes) using the back-and-forth pattern of movement shown in Figure 1.

Rinse the washed test panels with cold water, then clean them with a suitable solvent, e.g. white spirit, using soft, non-scratching paper tissues and wiping in the direction of the scratches. Finally, leave for 10 min to dry off. This process is designed to remove all residues of silica powder, and any abraded material from the brush.

**NOTE** Special boiling point spirit 60/95 has been found most suitable for cleaning painted surfaces to remove abrasion marks produced by the brush. Generally, preliminary tests for chemical resistance are necessary, however.

Verify the test apparatus regularly using a control panel (see Clause A.1).

If the test equipment is not to be used for some time (more than 8 h), it is recommended that it be rinsed thoroughly with tap water.

## 9 Evaluation

Within 2 h of drying, examine the test panels as follows:

- visually, as described in ISO 13076, for any change except in gloss, haze and colour, designating the change in accordance with ISO 4628-1;
- for gloss, in accordance with ISO 2813;
- for haze, in accordance with ISO 13803;
- for colour, in accordance with ISO 7724.

Measure the gloss, haze or colour of the test panels across the direction of scratching. Only make measurements in the test area (see 3.4).

Calculate the mean of three readings across the entire area of damage on the test panels. From these values, calculate the difference in gloss, haze or colour, or the percentage change in gloss or haze and the difference in colour ( $\Delta E$ ), relative to the initial reading. If agreed, an optical imaging analysis may be carried out.

Depending on the paint system used, the reflow effect, i.e. the self-repairing effect, might be more or less evident. The conditions of the evaluation after washing shall therefore be agreed between the interested parties.

## 10 Precision

### 10.1 Repeatability limit $r$

The repeatability limit  $r$  is the value below which the absolute difference between two single test results, each the mean of duplicates, can be expected to lie when this method is used under repeatability conditions, i.e. when the test results are obtained on identical material by one operator in one laboratory within a short interval of time using the standardized test method. For this method, in the case of gloss measurement (reflectometer readings),  $r$  is 14 units, with a 95 % probability.

### 10.2 Reproducibility limit $R$

The reproducibility limit  $R$  is the value below which the absolute difference between two test results, each the mean of duplicates, can be expected to lie when this test method is used under reproducibility conditions, i.e. when the test results are obtained on identical material by operators in different laboratories using the standardized test method. For this method, in the case of gloss measurement (reflectometer readings),  $R$  is 20 units, with a 95 % probability.

## 11 Test report

The test report shall contain at least the following information:

- a) all information necessary for the identification of the sample tested (manufacturer, product name, batch number, etc.);
- b) a reference to this International Standard (ISO 20566:2013);
- c) details of the procedure, including:
  - 1) the type of test panel used and its dimensions,
  - 2) the spraying, drying/hardening and stoving parameters, and any ageing and conditioning before the test,

## ISO 20566:2013(E)

- 3) the temperature at which the test was carried out,
  - 4) the test result obtained with the control panel,
  - 5) the total running time (age) of the washing brush,
  - 6) any specific agreements not otherwise mentioned in 1) to 5);
- d) the results of the test, including the results of the individual measurements and their mean, calculated as specified in Clause 9;
  - e) any deviations from the procedure specified;
  - f) any unusual features (anomalies) observed during the test;
  - g) the date of the test;
  - h) the name of the person who carried out the test.

## Annex A (normative)

### Verification and calibration of the washing equipment

#### A.1 Verification of the washing equipment

The condition of the washing equipment shall be verified regularly using suitable control panels.

As a result of their nature, the polyethylene brushes are subject to continuous change during use, i.e. test results will not, over time, remain constant. The scratching effect which they produce becomes more pronounced after long periods of use. Control panels are used to monitor the state of the brush so that, when necessary, the brush can be replaced.

The control panel material shall be chosen to reflect any changes in the washing brush, so that it is possible to differentiate between a new and used brush. In practice, the maximum lifetime of the washing brush is often specified as between 30 h and 50 h.

#### A.2 Calibration of the washing equipment

##### A.2.1 Apparatus

Ordinary laboratory equipment, together with the following:

**A.2.1.1 Sheet of cardboard**, measuring approximately 500 mm × 130 mm.

**A.2.1.2 Stopwatch.**

##### A.2.2 Procedure

Set up the equipment as shown in Figure A.1, with the calibration material (e.g. a sheet of cardboard, A.2.1.1) in a suitable holder in the path of the spray jet. Fill the container with washing suspension (see Clause 5). Determine the flow rate of the washing suspension by measurement of the volume or by weighing, and adjust, if necessary, to  $(2,2 \pm 0,2)$  l/min by altering the pressure. Start the spraying process and allow it to continue for approximately 60 s. Immediately after spraying, mark the outline of the wetted area. Check the spray pattern of both nozzles in this way (see Figure A.2).

Dimensions in millimetres

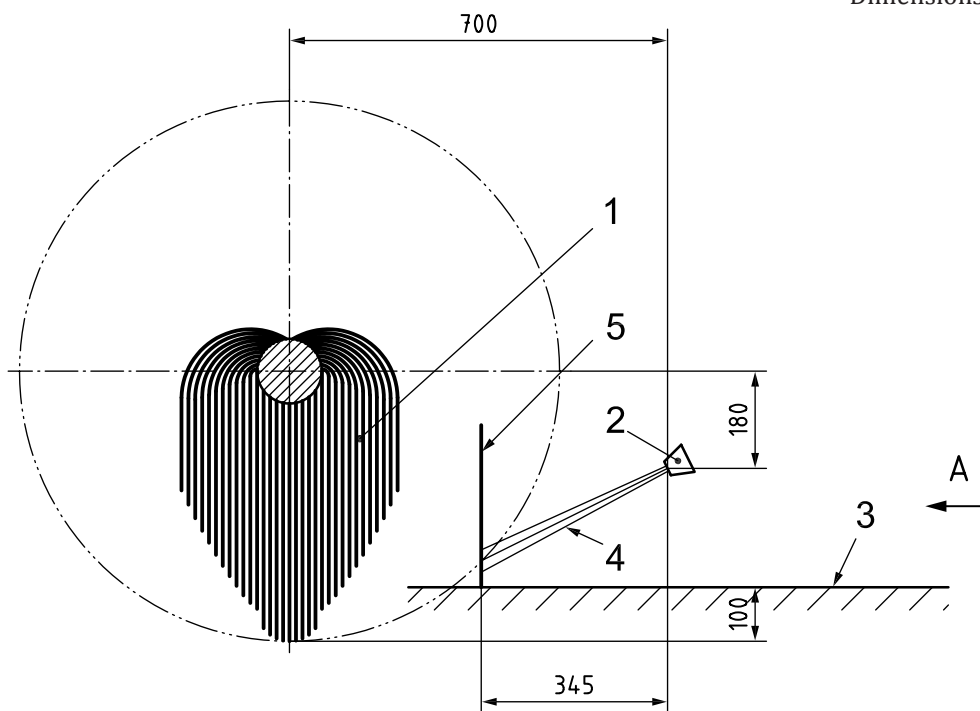

**Key**

- 1 brush
- 2 spray nozzle
- 3 test panel holder
- 4 spray jet
- 5 holder with the calibration material, e.g. a sheet of cardboard

a View A (see Figure A.2).

**Figure A.1 — Calibration arrangement**

Dimensions in millimetres

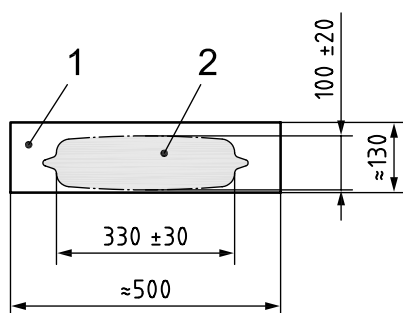

**Key**

- 1 calibration material, e.g. a sheet of cardboard
- 2 spray pattern

**Figure A.2 — Example of the view, including dimensions for this example**

.....

