**Road vehicles — Degrees of protection
(IP-Code) — Protection of electrical
equipment against foreign objects, water
and access**

*Véhicules routiers — Degrés de protection (codes IP) — Protection des
équipements électriques contre les corps étrangers, l'eau et les
contacts*



PDF disclaimer

This PDF file may contain embedded typefaces. In accordance with Adobe's licensing policy, this file may be printed or viewed but shall not be edited unless the typefaces which are embedded are licensed to and installed on the computer performing the editing. In downloading this file, parties accept therein the responsibility of not infringing Adobe's licensing policy. The ISO Central Secretariat accepts no liability in this area.

Adobe is a trademark of Adobe Systems Incorporated.

Details of the software products used to create this PDF file can be found in the General Info relative to the file; the PDF-creation parameters were optimized for printing. Every care has been taken to ensure that the file is suitable for use by ISO member bodies. In the unlikely event that a problem relating to it is found, please inform the Central Secretariat at the address given below.

© ISO 2006

All rights reserved. Unless otherwise specified, no part of this publication may be reproduced or utilized in any form or by any means, electronic or mechanical, including photocopying and microfilm, without permission in writing from either ISO at the address below or ISO's member body in the country of the requester.

ISO copyright office
Case postale 56 • CH-1211 Geneva 20
Tel. + 41 22 749 01 11
Fax + 41 22 749 09 47
E-mail copyright@iso.org
Web www.iso.org

Published in Switzerland

Contents

Page

Foreword.....	iv
Introduction	v
1 Scope	1
2 Normative references	1
3 Terms and definitions.....	1
4 Structure and significance of the IP-code.....	2
4.1 Structure of the IP-code	2
4.2 Significance of IP-code	3
4.3 Examples for the use of letters in the IP-Code	4
5 Degrees of protection against foreign objects and against access	4
6 Degrees of protection against water.....	5
7 Designation examples	6
7.1 General.....	6
7.2 Example IP34K	6
7.3 Example IP16KB.....	7
7.4 Example IP2X/IP5KX.....	7
8 Requirements and testing.....	8
8.1 Atmospheric conditions.....	8
8.2 Device under test (DUT)	8
8.3 Requirements and tests for degrees of protection against foreign objects and access	8
8.4 Requirements and test for degrees of protection against water	14
9 Notes on the assignment of degrees of protection.....	14
9.1 Assignment of degrees of protection against foreign objects and access.....	14
9.2 Assignment of degrees of protection against water.....	14
9.3 Determining the impact force distribution of a fan jet nozzle for test 9K	18
Bibliography	23

Foreword

ISO (the International Organization for Standardization) is a worldwide federation of national standards bodies (ISO member bodies). The work of preparing International Standards is normally carried out through ISO technical committees. Each member body interested in a subject for which a technical committee has been established has the right to be represented on that committee. International organizations, governmental and non-governmental, in liaison with ISO, also take part in the work. ISO collaborates closely with the International Electrotechnical Commission (IEC) on all matters of electrotechnical standardization.

International Standards are drafted in accordance with the rules given in the ISO/IEC Directives, Part 2.

The main task of technical committees is to prepare International Standards. Draft International Standards adopted by the technical committees are circulated to the member bodies for voting. Publication as an International Standard requires approval by at least 75 % of the member bodies casting a vote.

Attention is drawn to the possibility that some of the elements of this document may be the subject of patent rights. ISO shall not be held responsible for identifying any or all such patent rights.

ISO 20653 was prepared by Technical Committee ISO/TC 22, *Road vehicles*, Subcommittee SC 3, *Electrical and electronic equipment*.

Introduction

The IP-codes used in this International Standard are in accordance with IEC 60529 except specific codes “K” describing special requirements for road vehicles not covered by IEC 60529.

Copyright International Organization for Standardization

Road vehicles — Degrees of protection (IP-Code) — Protection of electrical equipment against foreign objects, water and access

1 Scope

This International Standard applies to degrees of protection (IP-Code) provided by enclosures of the electrical equipment of road vehicles. It specifies the following:

- a) Designations and definitions of types and degrees of protection provided by enclosures of electrical equipment (IP-Code) for the:
 - protection of electrical equipment within the enclosure against ingress of foreign objects, including dust (protection against foreign objects);
 - protection of electrical equipment inside the enclosure against effects due to ingress of water (protection against water);
 - protection of persons against access to hazardous parts inside the enclosure (protection against access).
- b) Requirements for each degree of protection.
- c) Tests to be carried out in order to confirm that the enclosure complies with requirements of the relevant degree of protection.

2 Normative references

The following referenced documents are indispensable for the application of this document. For dated references, only the edition cited applies. For undated references, the latest edition of the referenced document (including any amendments) applies.

ISO 12103-1, *Road vehicles — Test dust for filter evaluation — Part 1: Arizona test dust*

IEC 60068-2-68, *Environmental testing — Part 2: Tests — Test L: Dust and sand*

IEC 60529, *Degrees of protection by enclosures (IP-Code)*

3 Terms and definitions

For the purposes of this document, the following terms and definitions apply.

3.1

enclosure

part providing protection of equipment against certain external influences and in any direction against access

3.2
degree of protection

protection provided by an enclosure against access, foreign objects and/or water and verified by standardized test methods

[IEC 60529]

3.3
International Protection code
IP-code

coding system to indicate the degree of protection provided by an enclosure against access, foreign objects and/or water and to give additional information in connection with such parts

[IEC 60529]

3.4
hazardous part

part that is hazardous to approach or touch

[IEC 60529]

3.5
opening

gap or aperture in an enclosure which exists or may be formed by the application of a test probe at the specified force

[IEC 60529]

4 Structure and significance of the IP-code

4.1 Structure of the IP-code

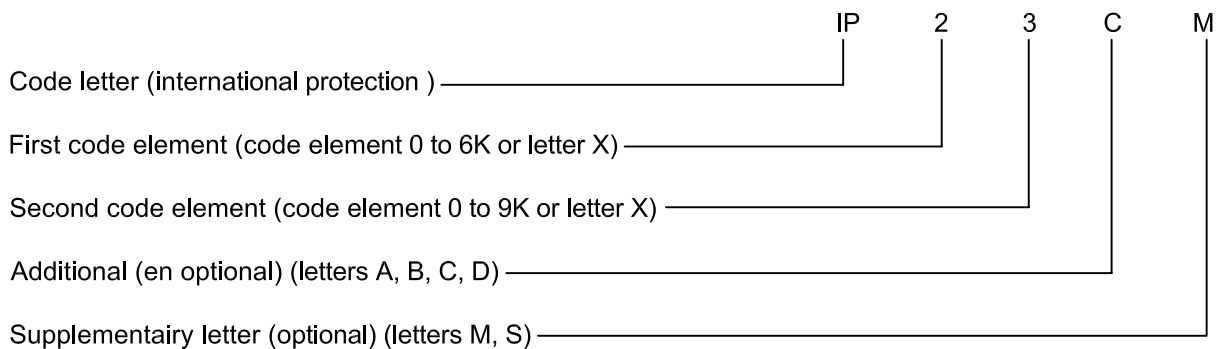

Where no code element is given, the letter "X" shall be substituted (or "XX", if none of the two code elements have been indicated).

Additional and/or supplementary letters may be omitted without substitute.

Letters following each other directly shall be arranged in alphabetical order.

Wherever the degree of protection of a part of the enclosure or the electrical equipment deviates from the degree of protection of the remaining part, both degrees of protection shall be indicated.

4.2 Significance of IP-code

Table 1 contains an overview of the IP-code elements.

Table 1 — Overview of all IP-Code elements and significance

Element	IP	Significance for the protection of electrical equipment	Significance for the protection of persons
First code element	0	— not protected	Against access: — not protected
	1	— with diameter \geq 50 mm	— with back of hand
	2	— with diameter \geq 12,5 mm	— with finger
	3	— with diameter \geq 2,5 mm	— with tool
	4	— with diameter \geq 1,0 mm	— with wire
	5K	— dust-protected	— with wire
	6K	— dust-tight	— with wire
Second code element	0	Against water: — not protected	
	1	— vertical water drips	
	2	— water drips (15° inclination)	
	3	— water spray	
	4	— splash water	
	4K	— splash water with increased pressure	
	5	— high-velocity water	
	6	— strong high-velocity water	
	6K	— strong high-velocity water with increased pressure	
	7	— temporary immersion	
8	— continuous submersion		
9K	— high-pressure/steam-jet cleaning		
Additional letter (optional)	A		Against access (unless described by first letter) — with back of hand
	B		— with finger
	C		— with tool
	D		— with wire
Supplementary letter (optional)	M	Movement of movable parts ^a during water test	
	S	Standstill of movable parts ^a during water test	
^a e.g. of the rotor of an electrical machine			

4.3 Examples for the use of letters in the IP-Code

The following examples explain the use and arrangements of letters in the IP-Code. For more comprehensive examples, see Clause 7.

IP 44	no letters, no options;
IPX5	omitting first characteristic numeral;
IP2X	omitting second characteristic numeral;
IP20C	using additional letter;
IPXXC	omitting both characteristic numerals, using additional letter;
IPX1C	omitting first characteristic numeral, using additional letter;
IP3XD	omitting second characteristic numeral, using additional letter;
IP23S	using supplementary letter;
IP21CM	using additional letter and supplementary letter;
IPX5/IPX7	giving two different degrees of protection by an enclosure against both water jets and temporary immersion for “versatile” application.

5 Degrees of protection against foreign objects and against access

Tables 2 and 3 contain short descriptions of the degrees of protection with the relevant requirements.

The same degree of protection (identical code element) for protection against foreign objects and access shall be provided. In this case, both are only indicated by the first code element.

Different degrees of protection for both protection types may be defined by adding the additional letter, whereby in this case the first code element only defines the protection against foreign objects and the additional letter only the protection against access.

Additional letters may only be used if:

- the degree of protection against access is higher than indicated by the first code element, or
- only the degree of protection against access is to be indicated (first code element substituted by X).

The indication of a degree of protection against access and foreign objects always includes the preceding degrees of protection.

Table 2 — Degrees of protection against foreign objects

First code element	Degree of protection	
	Brief description	Requirements
0	Not protected	None.
1	Foreign objects diameter ≥ 50 mm	Test probe with diameter 50 mm shall not penetrate completely.
2	Foreign objects diameter $\geq 12,5$ mm	Test probe with diameter 12,5 mm shall not penetrate completely.
3	Foreign objects diameter $\geq 2,5$ mm	Test probe with diameter 2,5 mm shall not penetrate completely.
4	Foreign objects diameter $\geq 1,0$ mm	Test probe with diameter 1,0 mm shall not penetrate completely.
5K	Dust	Dust shall only penetrate in quantities which do not impair performance and safety.
6K	Dust	Dust shall not penetrate.
“Shall not penetrate completely” indicates that the full diameter shall not pass through an opening of the enclosure.		

Table 3 — Degrees of protection against access

First code element	Additional letter	Degree of protection	
		Brief description	Requirements
0	—	Not protected	None.
1	A	Back of hand (no protection against intentional contact)	Test probe with diameter 50 mm shall not penetrate completely and maintain sufficient distance from hazardous parts.
2	B	Finger	Jointed test finger with diameter 12 mm may penetrate completely, but shall maintain a sufficient distance from hazardous parts.
3	C	Tool (e.g. screwdriver)	Test probe with diameter 2,5 mm, 100 mm long, may penetrate completely, but shall maintain a sufficient distance from hazardous parts.
4	D	Wire	Test probe with diameter 1,0 mm, 100 mm long, may penetrate completely, but shall maintain a sufficient distance from hazardous parts.
5K	D	Wire	
6K	D	Wire	
“Shall not penetrate completely” indicates that the full diameter shall not pass through an opening of the enclosure.			

6 Degrees of protection against water

Table 4 contains short descriptions of the degrees of protection with the relevant requirements.

The degrees of protection 1 to 6K for the protection against water always include the preceding degrees of protection. Due to different physical effects, this does not apply automatically for the degrees of protection against water 7, 8 and 9K.

Should this apply nevertheless, the included lower degree of protection shall be indicated separately, e.g. IPX4K/IPX7, IPX5/IPX7, IPX6K/IPX8 or IPX6K//IPX9K.

Table 4 — Degrees of protection against water

Second code element	Brief description	Degree of protection
		Requirements
0	Not protected	None.
1	Water drips vertically	Vertical drips shall not have any harmful effects.
2	Water drips with enclosure inclined by 15°	Vertical drips shall not have any harmful effects when the enclosure is tilted at any angle up to 15° on either side of the vertical.
3	Water spray	Water spray which sprays against the enclosure from any direction at a 60° angle shall not have any harmful effects.
4	Splash water	Water which splashes against the enclosure from any direction shall not have any harmful effects.
4K	Splash water with increased pressure	Water which splashes against the enclosure from any direction with increased pressure shall not have any harmful effects.
5	High-velocity water	Water which is directed against the enclosure from any direction as a jet shall not have any harmful effects.
6	Strong high-velocity water	Water which is directed against the enclosure from any direction as a strong jet shall not have any harmful effects.
6K	Strong high-velocity water with increased pressure	Water which is directed against the enclosure from any direction as a strong jet with increased pressure shall not have any harmful effects.
7	Temporary immersion in water	Water shall not penetrate in a quantity causing harmful effects if the enclosure is immersed in water temporarily under specified pressure and time conditions.
8	Continuous immersion in water	Water shall not penetrate in a quantity causing harmful effects if the enclosure is continuously immersed in water under conditions which shall be agreed between supplier and car manufacturer, but which are more severe than code 7.
9K	Water during high-pressure/steam-jet cleaning	Water which is directed against the enclosure from any direction shall not have any detrimental effect.

7 Designation examples

7.1 General

The degree of protection shall be indicated using the IP-Code.

7.2 Example IP34K

The marking of an enclosure with the IP-Code IP34K means:

- (3) Protection of the electrical equipment within the enclosure against foreign objects with a diameter of more than 2,5 mm (protection against foreign objects),
and
protection of persons handling rods of 2,5 mm diameter or more against access within the enclosure (protection against access).
- (4K) Protection of electrical equipment within the enclosure against harmful effects resulting from water splashing against the enclosure with increased pressure from any direction (protection against water).

7.3 Example IP16KB

The marking of an enclosure with the IP-Code IP16KB means:

- (1) Protection of the electrical equipment within the enclosure against foreign objects with a diameter of more than 50 mm (protection against foreign objects).
- (6K) Protection of electrical equipment within the enclosure against harmful effects resulting from water directed against the enclosure from any direction as a strong jet with increased pressure (protection against water).
- (B) Protection of persons against finger contact with hazardous parts within the enclosure (protection against access).

7.4 Example IP2X/IP5KX

The designation

- IP2X for the complete enclosure, or
- IP5KX for the cover of a part inside the complete enclosure,

means:

- (2) Protection of the electrical equipment within the complete enclosure against foreign objects with a diameter of more than 12,5 mm (protection against foreign objects),
and
protection of persons against finger contact with hazardous parts within the complete enclosure (protection against access).
- (X) No statement on the degree of protection against water for the complete enclosure, and additionally
- (5K) protection of the part against harmful effects resulting from ingress of dust (protection against foreign objects),
and
protection of persons handling wires of 1 mm diameter or more against contact with hazardous parts within the cover of this part (protection against access).
- (X) No statement on the degree of protection against ingress of water for the cover of this part.

NOTE 1 If all other parts are also not harmed by the penetrated dust, apart from protection against foreign objects degree 2, insensitivity to dust within the complete enclosure is also achieved.

NOTE 2 This higher degree of protection of the cover of the part located within the complete enclosure does not influence the complete enclosure surrounding it, whose lower degree of protection 2 applies.

8 Requirements and testing

8.1 Atmospheric conditions

Unless otherwise specified, tests shall be carried out under the following ambient atmospheric conditions:

- Temperature range: (23 ± 5) °C;
- Relative humidity: 25 % to 75 %;
- Atmospheric pressure: 86 kPa to 106 kPa (860 mbar to 1 060 mbar).

8.2 Device under test (DUT)

Unless otherwise agreed, the DUT shall be unused and clean.

Further specifications regarding DUT may be made.

8.3 Requirements and tests for degrees of protection against foreign objects and access

8.3.1 Test set-up

Probes for determining the degrees of protection against access and foreign objects are shown in Table 5.

Shutting the guard and handle impede practical testing. The tests shall be carried out with the ball only.

A test set-up for determining degrees of protection against foreign objects 5K and 6K (dust-protected or dust-tight) with vertical flow of the air-dust mixture is depicted in Figure 1. Alternatively, a dust chamber with horizontal dust flow (see Figure 2) can be agreed upon, based on IEC 60068-2-68.

Unless otherwise agreed, test dust A2 (Arizona dust) according to ISO 12103-1 shall be used.

Where a dust chamber in accordance with Figure 1 is used, approximately 2 kg of test dust per m³ chamber volume shall be filled in and kept in suspension during the test. Where dust chambers according to Figure 2 are used, the density of the air/dust mixture shall be (5 ± 2) g/m³ and a flow rate of 1,5 m/s shall be maintained in accordance with IEC 60068-2-68 (unless otherwise agreed).

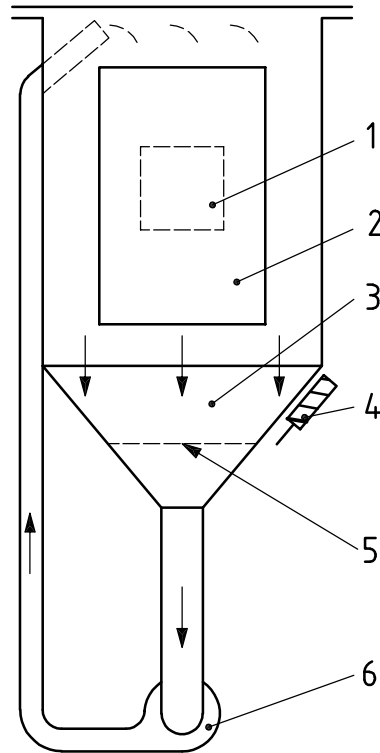

Key

- 1 DUT
- 2 glass window
- 3 dust
- 4 vibrator
- 5 protective grating
- 6 circulating pump or other equipment for suspending the dust

Figure 1 — Test set-up for determining the protection against dust (example of a dust chamber with vertical flow of the air/dust mixture; a flow from top to bottom is illustrated here); degree of protection against foreign objects 5K and 6K

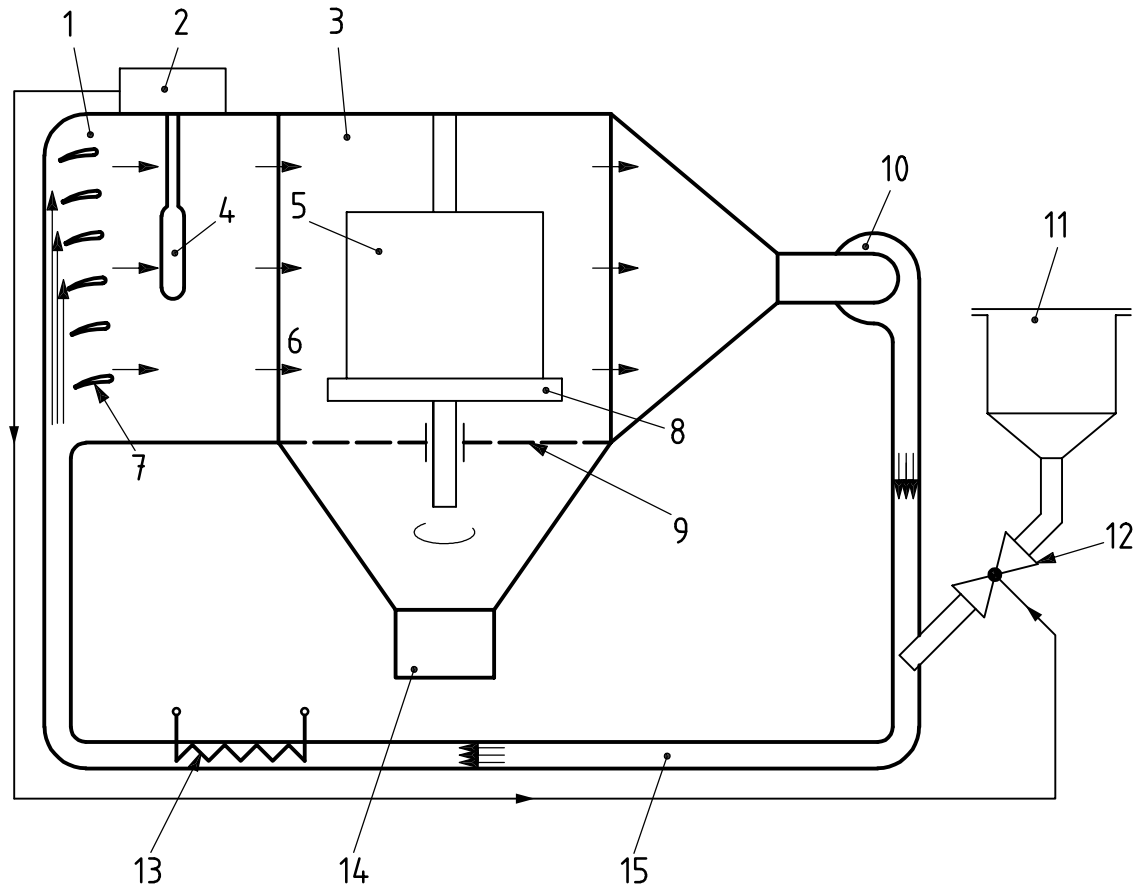

Key

- | | |
|--|---|
| 1 pre-chamber | 9 protective grating |
| 2 dust density controller (control unit) | 10 dust circulating pump (radial fan) |
| 3 test chamber | 11 reservoir for test dust |
| 4 probe | 12 solenoid valve (proportioning valve) |
| 5 DUT | 13 heating |
| 6 laminar air flow | 14 collecting tank for test dust |
| 7 air baffles | 15 air duct |
| 8 test bench | |

Figure 2 — Test set-up for determining the degree of protection against dust (example of a dust chamber with horizontal flow of the air/dust mixture); protection against foreign objects 5K and 6K

8.3.2 Requirements for tests using probes

The requirements for tests using the probes according to Table 5 are specified in Table 6.

Table 5 — Probes for the testing of degrees of protection against foreign objects and access

Degree of protection against foreign objects or First code element	Degree of protection against access or First code element or additional letter	Test probe designation and dimension
1	1 or A	<p>Sphere diameter 50 Dimensions in millimetres</p>  <p>Key</p> <ul style="list-style-type: none"> 1 handle (insulating material) 2 guard (insulating material) 3 rigid test sphere (metal)
—	2 or B	<p>Jointed test finger diameter 12; 80 length Dimensions in millimetres</p>  <p>Key</p> <ul style="list-style-type: none"> 1 stop face (diameter 50 × 20) (insulating material) 2 jointed test finger (metal)
2	—	<p>Sphere diameter 12,5 Dimensions in millimetres</p>  <p>Key</p> <ul style="list-style-type: none"> 1 handle (insulating material) 2 guard (insulating material) 3 rigid test sphere (metal)

Table 5 (continued)

Degree of protection against foreign objects First code element	Degree of protection against access First code element or additional letter	Test probe designation and dimension
3	3 or C	<p>Test rod diameter 2,5; 100 long Dimensions in millimetres</p>  <p>Key</p> <ul style="list-style-type: none"> 1 handle (insulating material) 2 stop face (insulating material) 3 sphere 4 rigid test rod (metal) (edges free from burrs)
—	4/5/6 or D	<p>Test wire diameter 1,0; 100 long Dimensions in millimetres</p>  <p>Key</p> <ul style="list-style-type: none"> 1 handle (insulating material) 2 stop face (insulating material) 3 sphere 4 rigid test wire (metal) (edges free from burrs)

Table 6 — Test conditions and requirements for testing degrees of protection against foreign objects and access using probes

Degree of protection against foreign objects First code element	Degree of protection against access or First code element or additional letter	Test force $N \pm 10\%$	Requirements
0	0	—	None.
—	1 or A	50	The sphere (diameter 50 mm) shall not penetrate fully through any openings and shall have a sufficient distance from hazardous parts.
1	—		The sphere (diameter 50 mm) shall not penetrate fully through any opening.
—	2 or B	10	The jointed test finger may penetrate over its full length of 80 mm but shall be sufficiently distant from hazardous parts, even when its joints are bent at any optional angle (up to 90° from its axis) and are brought into any possible position. The stop face ($\varnothing 50$ mm \times 20 mm) shall not pass through the opening.
2	—	30	The sphere (diameter 12,5 mm) shall not penetrate fully through any opening.
—	C	3	The rigid test rod (diameter 2,5 mm, 100 mm long) may penetrate over its full length of 100 mm, but shall be sufficiently distant from hazardous parts in any possible angular position. The stop face (sphere $\varnothing 35$ mm) shall not pass through the opening.
3			The rigid test rod (diameter 2,5 mm) shall not penetrate.
—	D	1	The rigid test wire (diameter 1,0 mm, 100 mm long) may penetrate over its full length of 100 mm, but shall be sufficiently distant from hazardous parts in any possible angular position. The stop face (sphere $\varnothing 35$ mm) shall not pass through the opening.
4	4/5/6		The rigid test wire (diameter 1,0 mm) shall not penetrate.
Sufficient distance from hazardous parts has the following meaning: the probes shall not contact hazardous parts while hazardous parts are being moved slowly.			

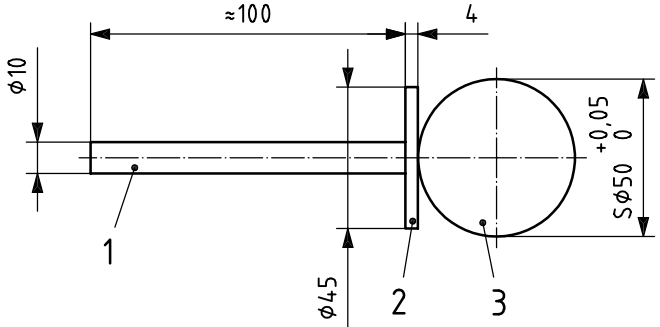
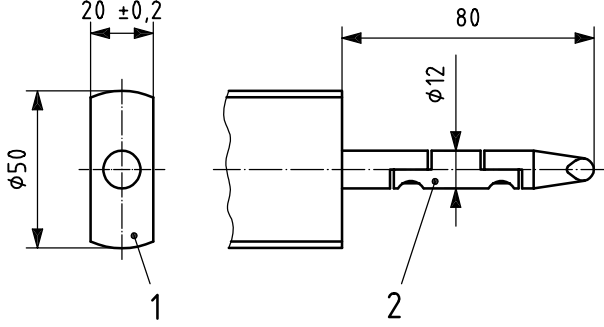
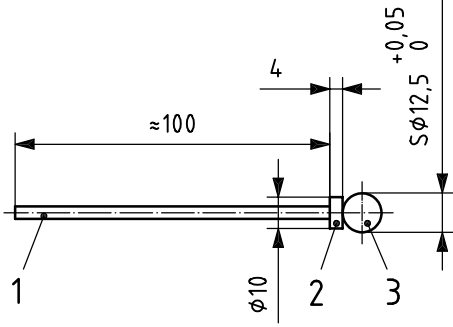
8.3.3 Requirements for testing with dust

8.3.3.1 Requirements

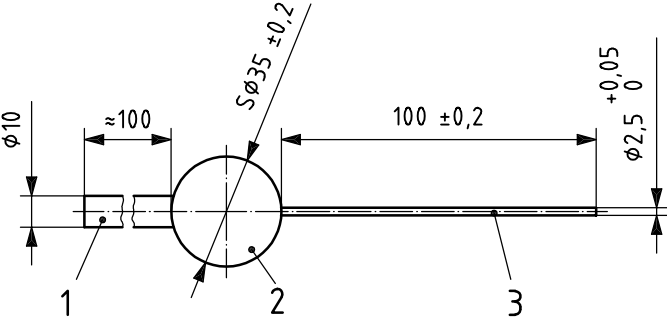
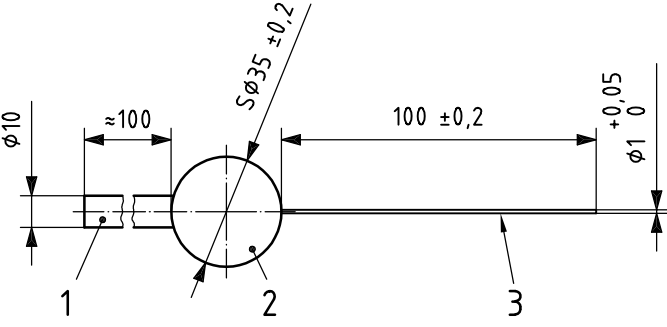
For requirements, refer to Table 2, which generally stipulates successful completion of an agreed performance test for degree of protection against foreign objects 5K. In special cases, a permissible degree of dust or another test criterion may be agreed upon.

8.3.3.2 Execution of the test for protection against ingress of dust

The enclosure to be tested shall be placed in the test chamber in its normal operating position, with all its shrouds, covers and open drain holes and exposed to the following conditions:

- a) Test chamber according to Figure 1:
 - 6 s movement of the air/dust mixture,
 - 15 min break.

Unless otherwise agreed, 20 such cycles shall be performed.

- b) Test chamber according to Figure 2:

Subject to agreement: exposure time 0,5 h to 24 h and speed (0 to 3) min⁻¹.

8.4 Requirements and test for degrees of protection against water

8.4.1 Test set-up

The test set-up and the spatial arrangement with reference to the DUT are illustrated in Figures 3 to 7, and 9.

8.4.2 Requirements

The requirements are contained in Table 4, whereby the acceptable quantity of penetrated water or another test criterion (e.g. passing a performance test to be specified) shall be agreed.

8.4.3 Tests

The test conditions are specified in Table 7.

9 Notes on the assignment of degrees of protection

9.1 Assignment of degrees of protection against foreign objects and access

The decisive criterion is the type of design of the enclosure and the impact of foreign bodies to be expected during operation of the relevant vehicle at the mounting or attachment position.

9.2 Assignment of degrees of protection against water

For examples refer to Table 8.

Dimensions in millimetres

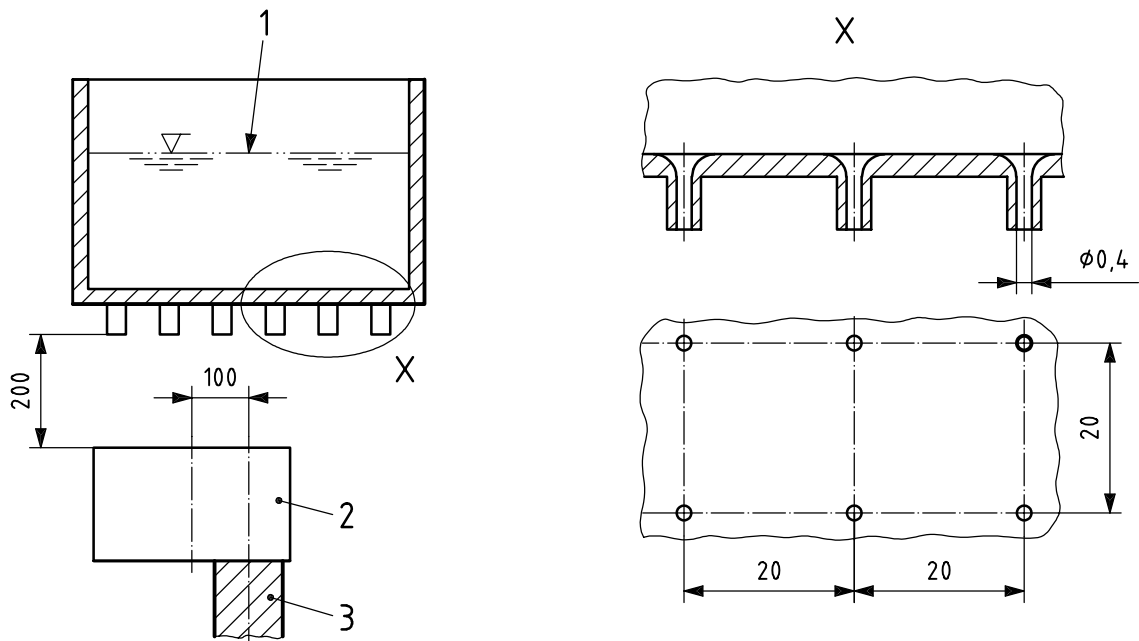

a) Degree of protection against water 1

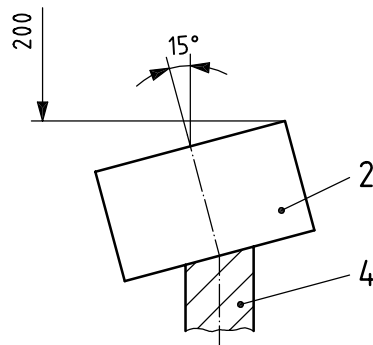

b) Degree of protection against water 2

Key

- 1 adjustable water level
- 2 DUT
- 3 turntable
- 4 holder

Figure 3 — Test set-up for determining the protection against vertical water drips (drip apparatus), degrees of protection against water 1 and 2

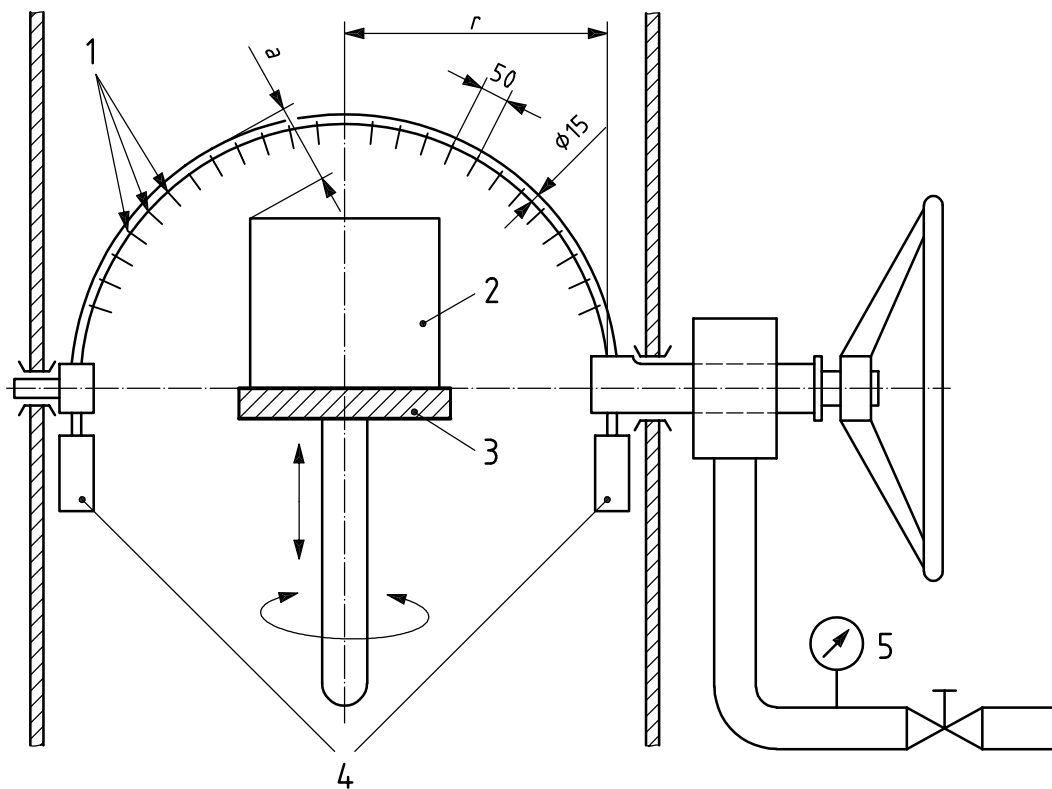

Key

1 holes with diameter D

2 DUT

3 turntable

4 counterweights

5 flow rate indicator and pressure gauge

r 200, 400, 600 or 800; select the smallest radius depending on the size of DUT

$D = 0,4$ for tests regarding degrees of protection against water 3 and 4

$D = 0,8$ for tests regarding degrees of protection against water 4K

Speed of DUT from $(1 \text{ to } 3) \text{ min}^{-1}$

Figure 4 — Test set-up for determining the protection against splash water and water spray (swivel tube); degrees of protection against water 3, 4 and 4K

Dimensions in millimetres

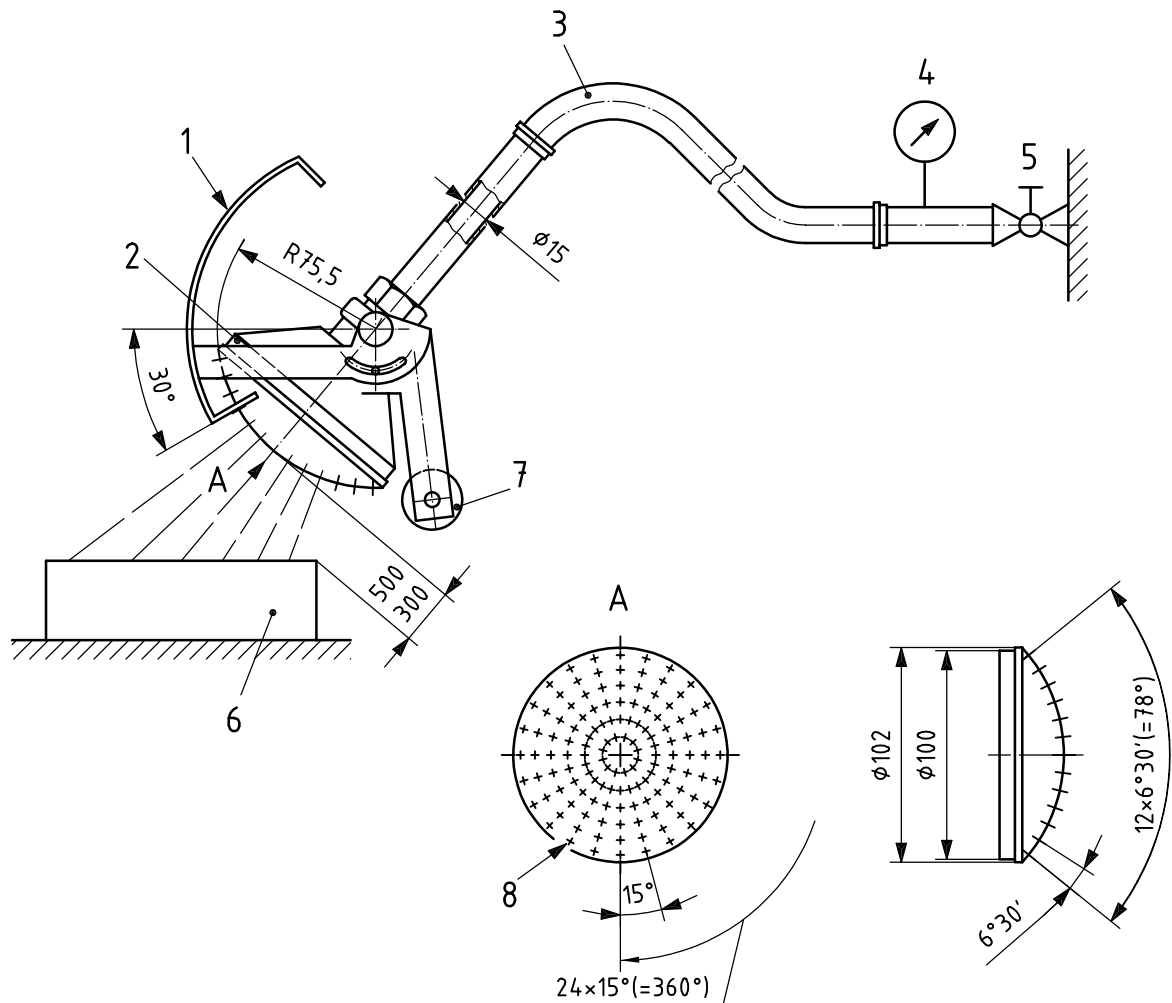

Key

- | | | | |
|---|--|---|-----------------------|
| 1 | moveable cover | 5 | stop-cock |
| 2 | shower tube | 6 | DUT |
| 3 | hose | 7 | counterweight |
| 4 | flow rate indicator and pressure gauge | 8 | diameter of apertures |

NOTE The shower tube contains 121 apertures with diameter 0,5 mm:

- 1 centre aperture,
- 2 inner circles (12 apertures at 30° pitch),
- 4 outer circles (24 openings at 15° pitch), and
- a moveable cover made from aluminium.

The shower tube shall be made from copper zinc alloy (brass).

Figure 5 — Manual test set-up for determining the protection against splash water and water spray (shower tube), degrees of protection against water 3 and 4

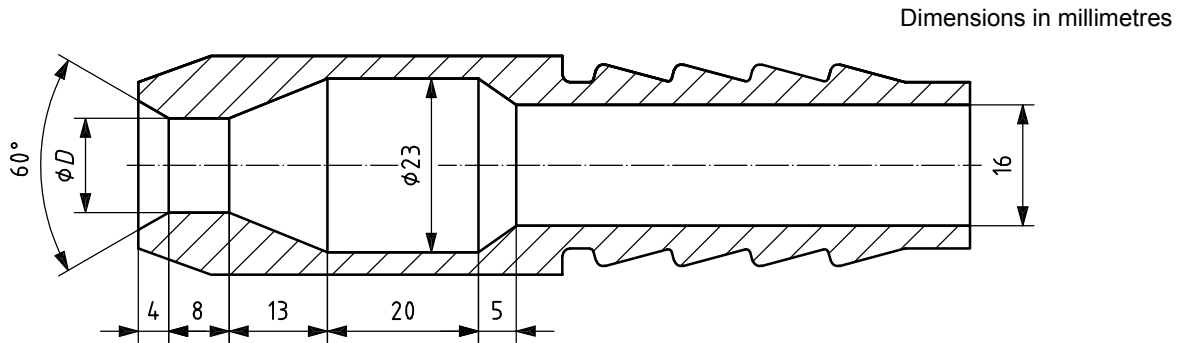

$D = 6,3$ for tests regarding degrees of protection against water 5 and 6K

$D = 12,5$ for tests regarding degree of protection against water 6

Figure 6 — Nozzle for determining the protection against high-velocity water, degrees of protection against water 5, 6 and 6K

9.3 Determining the impact force distribution of a fan jet nozzle for test 9K

A method of measurement for the impact force distribution of a fan jet nozzle and the requirements for the impact force distribution are illustrated in Figure 7.

- Dimensions of impact plate: $2 \times (30 \pm 01)$ mm
- Water pressure: $(10\ 000 \pm 500)$ kPa
- Flow rate: (15 ± 1) l/min

If the second code element is 3 to 6K, the required water pressure is normally set. Then check at appropriate intervals whether the required water flow rate is achieved and adjust the operating pressure of the equipment used, if necessary.

Measure water or steam pressure as close to the outlet as possible.

Dimensions in millimetres

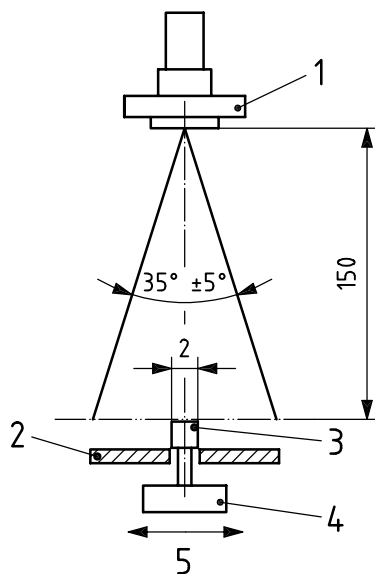

Key

- 1 fan jet; pressure (100 ± 5) bar; volume (15 ± 1) l/min
- 2 cover plate
- 3 impact plate 2×30 mm (2 mm in direction of movement)
- 4 force absorber
- 5 working width

Figure 7 — Set-up for measuring the impact force of the water jet for determining the protection against high-pressure/steam-jet cleaning, degree of protection against water 9K

Dimensions in millimetres

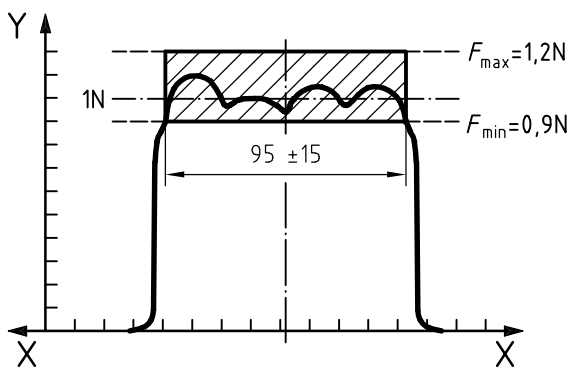
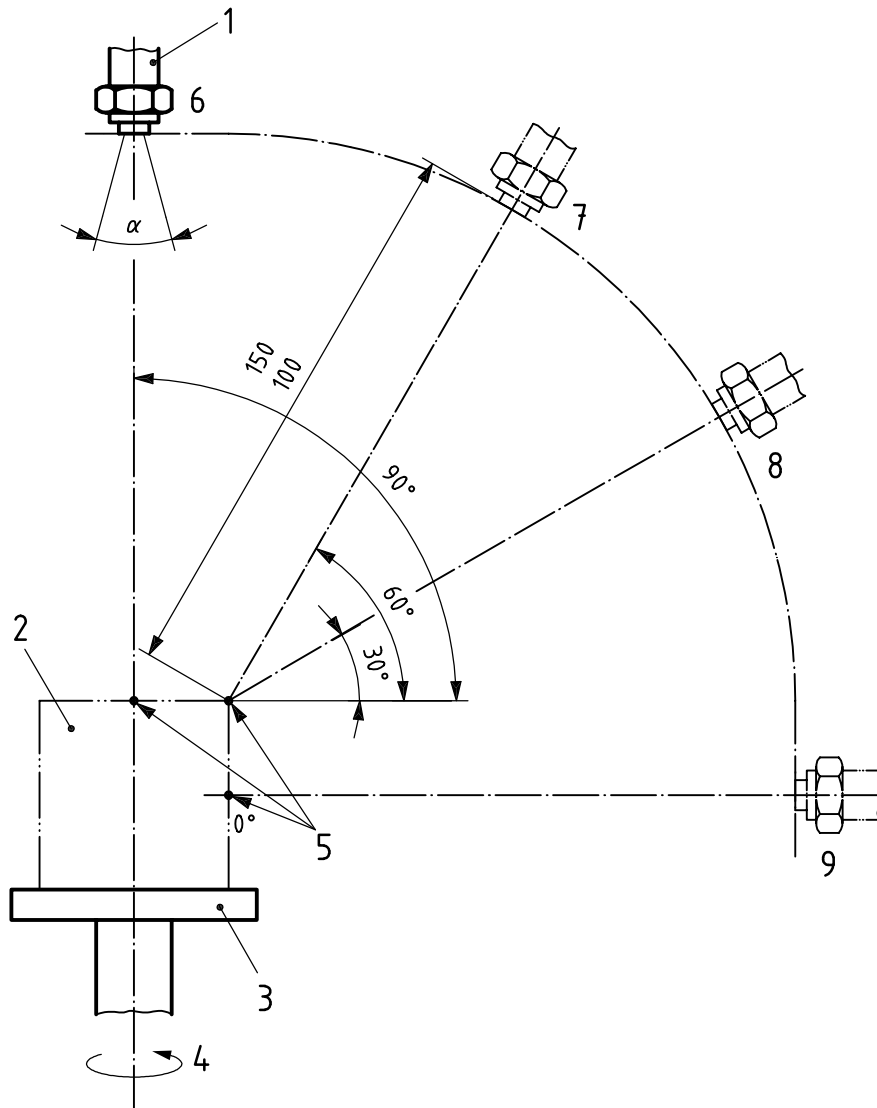

Figure 8 — Distribution of impact force for determining the protection against high-pressure/steam-jet cleaning, degree of protection against water 9K



Key

- | | |
|---|--------------|
| 1 fan jet nozzle | 6 position 1 |
| 2 DUT | 7 position 2 |
| 3 turntable | 8 position 3 |
| 4 swivel axis | 9 position 4 |
| 5 reference points (0°, 30°, 60°, 90°) endorsing cylinder for DUT | |

Figure 9 — Test set-up for determining the protection against high-pressure/steam-jet cleaning, degree of protection against water 9K

Table 7 — Test set-ups and conditions for testing degrees of protection against water

2 nd code element	Test equipment Test conditions	Water flow rate	Water pressure	Water temperature	Exposure time
0	—	—	—	—	—
1	Drip apparatus, Figure 3, enclosure on turntable, speed: approx. 1 r/min	(1,0 + 0,5) mm/min (precipitation height)	—	Difference of the temperature of the equipment under test no more than 5 °C. For water temperatures which are more than 5 °C lower, measures shall be agreed between the users of the standard to prevent the formation of condensed water.	10 min
2	Drip apparatus, Figure 3, enclosure in 4 fixed positions, inclined by 15°	(3,0 + 0,5) mm/min (precipitation height)	—		2,5 min for each of the four positions
3	Swivel tube, Figure 4, with apertures diameter 0,4 mm to ± 60° from the vertical plane spray while swivelling the swivel tube by ± 60° with reference to the vertical plane at a rate of approx. 1s/60°, max. distance: 200 mm	0,1 l/min ± 5 % per aperture (medium value)	approx. 80 kPa (refer to note)		10 min (5 min in one position, 5 min in a position swivelled from this position by 90° along the horizontal level)
	or shower tube, Figure 5, spray while swivelling the shower tube by ± 60° with reference to the vertical plane, max. distance: 500 mm	10 l/min ± 5 %	(50 to 150) kPa		5 min
4	Swivel tube, Figure 4, as under 3, but with apertures diameter 0,4 mm ± 90° from the vertical plane; spray while swivelling the swivel tube by ± (180° to 20°) with reference to the vertical plane at a rate of approx. 1s/60°, max. distance: 200 mm or shower tube, Figure 5, but with removable cover, cover removed, spray ... ± 90° ...	as under 3	as under 3		as under 3
4K	Swivel tube, Figure 4, as under 3, but with apertures diameter 0,4 mm ± 90° from the vertical plane, spray while swivelling the swivel tube by ± (180° to 20°) with reference to the vertical plane at a rate of approx. 1s/60°, max. distance: 200 mm	0,6 l/min ± 5 % per aperture (medium value)	approx. 400 kPa (refer to note)		10 min (5 min in one position, 5 min in a position swivelled from this position by 90°)
5	Water jet, Figure 6, nozzle 6,3 mm diameter distance: 2,5 m to 3 m	12,5 l/min ± 5 %	approx. 30 kPa (refer to note)		3 min
6	Water jet, Figure 6, nozzle 12,5 mm diameter distance: 2,5 m to 3 m	100 l/min ± 5 %	approx. 100 kPa (refer to note)		3 min
6K	Water jet, Figure 6, nozzle 6,3 mm diameter distance: 2,5 m to 3 m	75 l/min ± 5 %	approx. 1 000 kPa		min. 3 min
7	Immersion basin, immersion depth: 1 m (deepest housing location), 0,15 m (highest housing location, if housing is larger than 0,85 m)	—	—		30 min

Table 7 (continued)

2 nd code element	Test equipment Test conditions	Water flow rate	Water pressure	Water temperature	Exposure time
8	Submersion basin, water level: as agreed between the users of the standards	—	—	—	subject to agreement
9K	Fan jet nozzle, Figure 7, enclosure on turntable, Figure 8, speed (5 ± 1) r/min spray at 0°, 30°, 60°, 90° distance (100 to 150) mm	14 l/min to 16 l/min	approx. (8 000 to 10 000) kPa	(80 ± 5) °C Deviating temperatures may be agreed	30 s per position

Table 8 — Examples of the assignment of degrees of protection to types of vehicles and mounting situations

Type of vehicle	Mounting location	Water impact	Second code element
Passenger vehicles	Passenger compartment	No particular impact	0
	Engine compartment covered from underneath	No impact of water spray and splash water; only light spray mist at individual insignificant locations	3
	Engine compartment open underneath, protected locations	Spray and splash water can only impact indirectly (after deflection)	4
	Engine compartment open underneath, exposed locations	Spray and splash water can impact directly	4K
Motor buses as well as commercial vehicles; special vehicles and road tractors and relevant trailers	External attachment	Spray and splash water can impact directly	4K
	Passenger compartment, cab	No particular impact	0
	Front engine compartment, protected locations; closed rear engine compartment	Spray and splash water can only impact indirectly (after deflection)	4
Agricultural tractors and relevant trailers	Front engine compartment, exposed locations; unprotected under floor space	Spray and splash water can impact directly	4K
	Locations which are hit by very strong water jets (e.g. during cleaning before repairs, services)	High-velocity water with particularly high pressure is to be expected	6K
Motorcycles	External attachment	Spray and splash water can impact directly	4K
	Instrument panel of tractor with canopy top	No particular impact	0
Vehicles for special purposes	Instrument panel of tractor without canopy top	Impact of rain	3
	All locations which are not covered (with the exception of instrument panel)	Spray and splash water can impact directly	4K
All	Protected locations	Impact of rain; spray and splash water can only impact indirectly (after deflection)	3
	Handlebar, instrument panel, lower frame area	Spray and splash water can impact directly (rain while driving at high speed)	4K
All	Chassis, lower engine area and superstructure	Water pressure during passes through waterways	6, 7 or 8
	All, except passenger compartment	Cleaning process with high pressure / steam jet cleaning	9K

Bibliography

- [1] IEC 61032, *Protection of persons and equipment by enclosures — Probes for verification*

© ISO 2006. All rights reserved.

ICS 43.040.10

Price based on 23 pages